

Section: ENGINE

**CRANKCASE**

Fig.	P/n	QTY	Name
------	-----	-----	------

**Notes:**

[EXPLORER 75 SPECIAL]

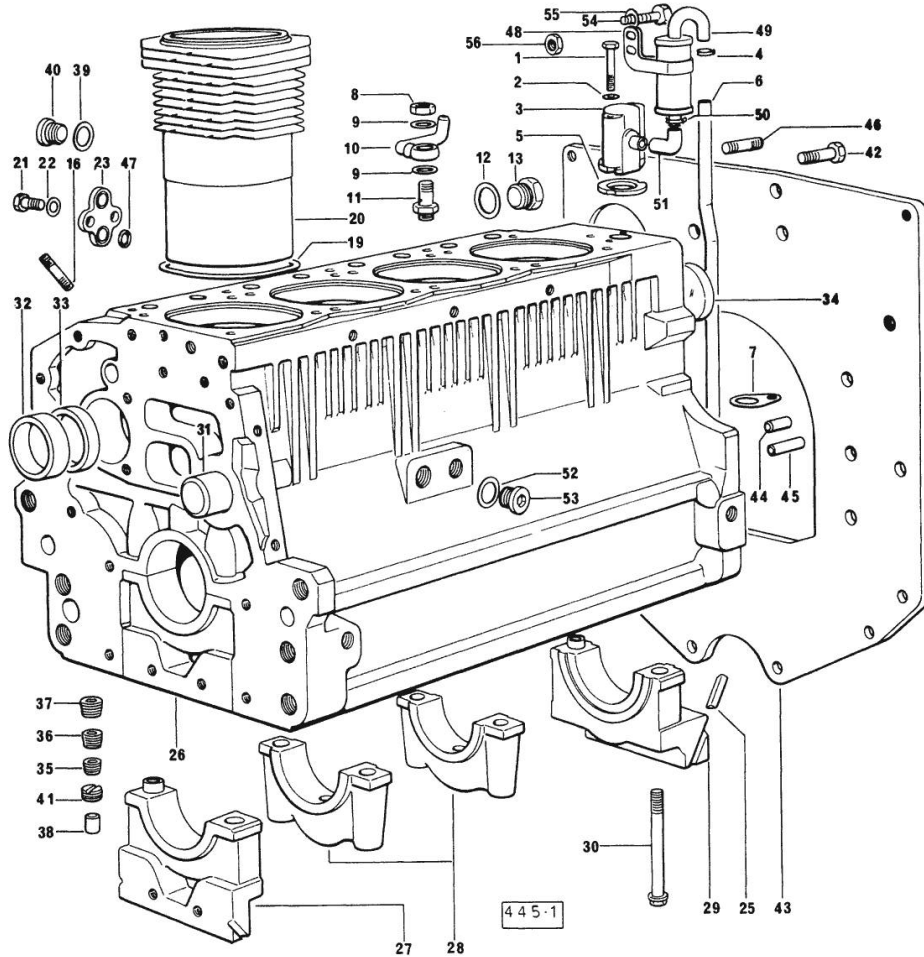

0	0.065.0050.6	1	gasket set FOR ENGINE ASSEMBLY 916.4 A
0	0.086.0050.6	1	gasket set FOR 1000.4A ENGINE ASSEMBLY
1	2.0312.219.2	2	screw m 8 p.1.25x65
2	2.1470.004.2	2	lock washer 8
3	0.065.1143.3/10	1	body
4	2.6859.072.2	1	clamp
5	0.065.1156.0	2	gasket
6	0.065.1155.0/10	1	tube
7	0.065.1157.0	1	bracket
8	2.1099.108.2	4	special nut m 10 p.1
9	2.1560.006.0	8	gasket 10.2 x 16
10	0.065.1158.2	4	old part number X 916.4 A
10	0.086.1550.2	4	sprayer nozzle X 1000.4 A
11	0.065.1160.3/20	4	valve
12	2.1539.047.2	1	old part number
13	2.3199.405.2	1	plug m 28 p.1.5
16	2.0439.154.1	12	old part number
19	2.1519.096.0	4	oil seal X 1000.4 A
19	2.1589.154.0	1	shoulder ring X 916.4 A
19	2.1589.155.0	4	shoulder ring X 916.4 A
19	2.1589.156.0	4	shoulder ring X 916.4 A
20	0.007.0762.0/30	4	engine cylinder -> 26013
20	0.065.1120.0/10	4	engine cylinder X 916.4 A
20	0.085.1120.0	4	old part number 26012 <- X 1000.4 A
21	2.0112.207.2	2	screw m 8 p 1.25 x 20
22	2.1470.004.2	2	lock washer 8
23	0.065.1163.0	1	flange
25	0.066.1152.0	4	gasket
26	0.065.1110.4/20	1	crankcase X 916.4 A

Section: ENGINE  
CRANKCASE

Fig.	P/n	QTY	Name
26	0.086.1110.4	1	crankcase X 1000.4 A
27	0.065.1112.7	1	support
27	2.1699.165.0	1	bush 12.3x15x16
28	0.065.1114.7	3	support
29	0.065.1116.7	1	support
29	2.1699.165.0	1	bush 12.3x15x16
30	0.065.1117.0	10	screw m 12 x 100
31	0.066.1151.0	1	pin
32	0.065.1141.0	1	special bushing 59X55X30
33	0.065.1140.0	4	special bushing 59X55X20
34	2.3179.012.0	1	plug 60
35	2.3130.001.1	10	plug 1/8" gas
36	2.3130.002.1	2	plug 1/4" gas
37	2.3130.003.1	7	plug 3/8" gas
38	2.3199.092.0	4	plug 8 x 12
39	2.1560.017.0	1	gasket 22.2 x 27
40	2.3120.002.4	1	plug m 22 x 1.5
41	2.1324.011.0	1	plug
42	2.0112.511.2	8	screw m 14 p.2 x 30
43	0.066.1130.0/10	1	old part number
44	2.1651.912.0	2	cylindrical plug 12x28
45	2.1651.917.0	1	cylindrical plug 12x40
46	2.0432.255.1	2	stud bolt m 12 p.1.75 - 12 p1.25x25
47	2.1539.048.0	2	special oil seal 20.35x1.78
48	2.6859.074.2/10	1	clamp
49	0.065.1165.2	1	sediment bowl
50	2.6859.073.2	2	clamp
51	0.065.1166.0	1	sleeve
52	2.1560.017.0	1	gasket 22.2 x 27
53	2.3120.002.4	1	plug m 22 x 1.5
54	2.0112.004.2	1	screw m 6 p.1 x 14
55	2.1470.002.2	1	lock washer 6
56	2.1011.103.2	1	nut m 6 p.1

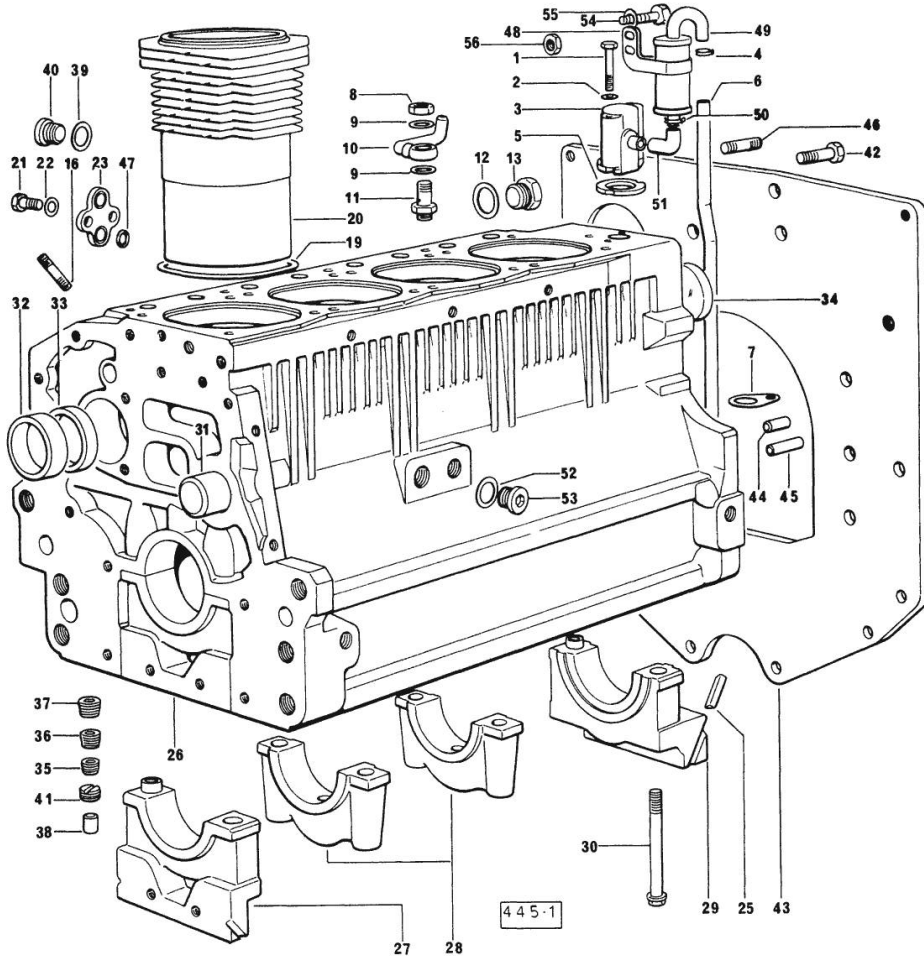

Section: ENGINE

**TIMING CASE**

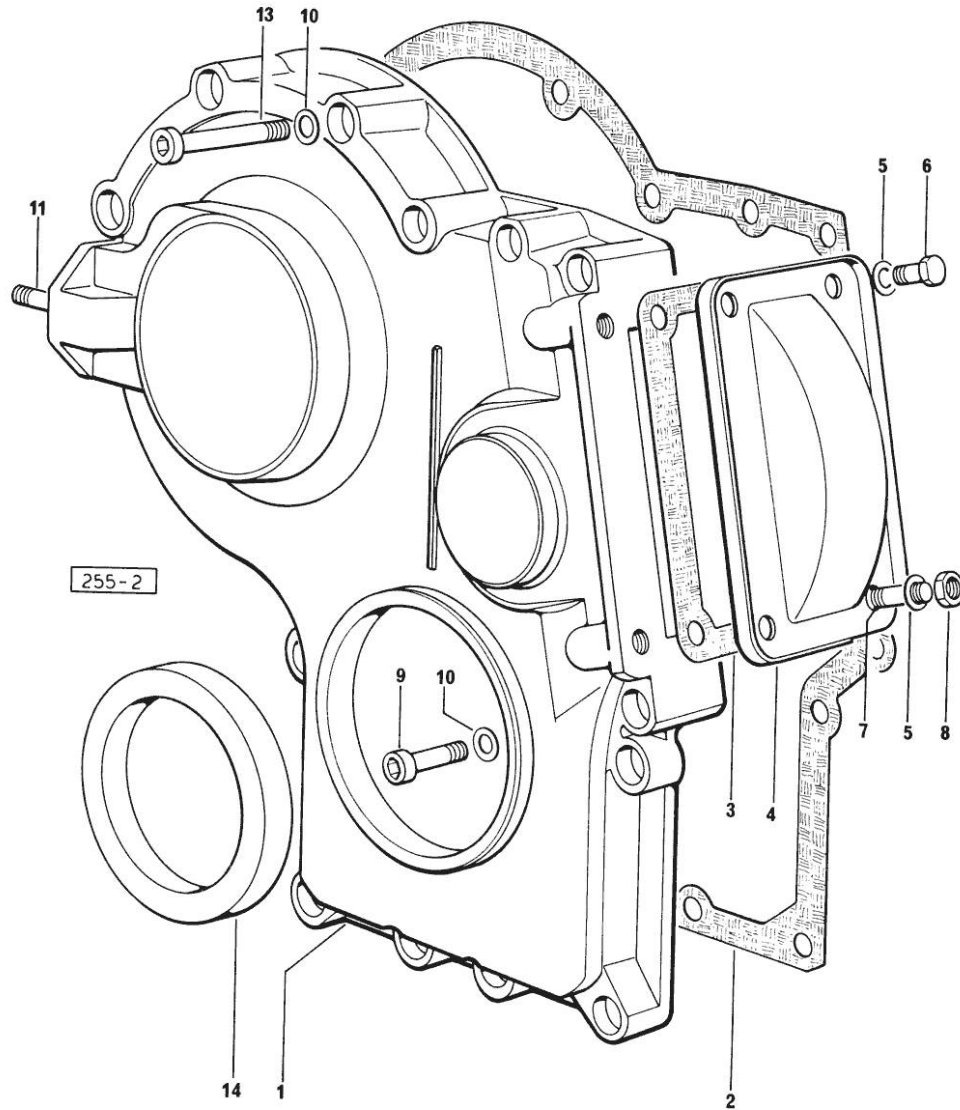

Notes:  
[EXPLORER 75 SPECIAL]

Fig.	P/n	QTY	Name
1	0.065.1132.0/20	1	guard
2	0.065.1150.0/10	1	gasket
3	0.065.1152.0	1	gasket
4	0.065.1151.0	1	cover
5	2.1470.004.2	4	lock washer 8
6	2.0112.205.2	2	screw m 8 p.1.25 x 16
7	2.0432.003.7	2	stud bolt m 8 p.1.25 / p.1 x 20
8	2.1011.405.2	2	nut m 8 p.1
9	2.0312.208.1	8	screw m 8 p.1.25 x 25
10	2.1480.014.1	15	washer 8
11	2.0439.154.2	2	stud bolt m 8 p.1x20
13	2.0312.214.2	3	screw m 8 p.1.25 x 40
13	2.0312.219.2	4	screw m 8 p.1.25x65
14	2.1529.072.0	1	oil seal

Section: ENGINE

CRANKSHAFT

Fig.	P/n	QTY	Name
------	-----	-----	------

Notes:

[EXPLORER 75 SPECIAL]

1	0.066.1210.3/20	1	crankshaft X 916.4 A
1	0.086.1210.3	1	crankshaft X 1000.4 A
2	0.065.1211.0/10	1	crown wheel
3	2.1630.608.0	1	pin 6x16
4	2.3130.001.1	4	plug 1/8" gas
5	0.065.1220.3/10	4	engine connecting rod X 916.4 A
5	0.078.1220.3/10	4	engine connecting rod - X 1000.4 W X 1000.4 A
6	2.0139.021.0	8	screw
7	0.065.1227.0	4	special bushing
8	2.1411.013.1	8	circlip 32 X 916.4 A
8	2.1411.014.1	8	circlip 35 X 1000.4 A
9	0.065.1236.0	4	piston pin X 916.4 A
9	0.078.1236.0	4	piston pin Ø 18 / Ø 35 / L = mm 86 X 1000.4 A
10	2.1720.006.0	1	key 4x6.5
11	0.065.1248.0/10	1	hub
12	2.1589.136.0	1	shoulder ring 71x110x0.5
12	2.1589.137.0	1	shoulder ring 71x110x1
13	2.0399.095.2/10	1	screw
14	2.1599.503.2	1	shoulder ring
15	2.0112.317.2	6	screw m 10 p.1.5 x 45
16	2.1470.006.2	6	lock washer 10
17	0.065.1244.0	1	pulley
18	0.065.1254.0	1	gasket
19	0.065.1253.0/10	1	cover
20	2.1529.073.0	1	special oil seal 110x130x13
21	2.0112.207.2	9	screw m 8 p 1.25 x 20
22	2.1474.009.1	9	spring washer 8
23	0.065.1225.0	8	con.rod half bushing STANDARD - A = 28.75 -> 29.00
24	0.065.1215.0	5	main half bushing STANDARD
25	0.065.1216.0	5	main half bushing
26	0.065.1218.0	4	shim STANDARD
27	0.065.0060.6	4	complete piston X 916.4 A

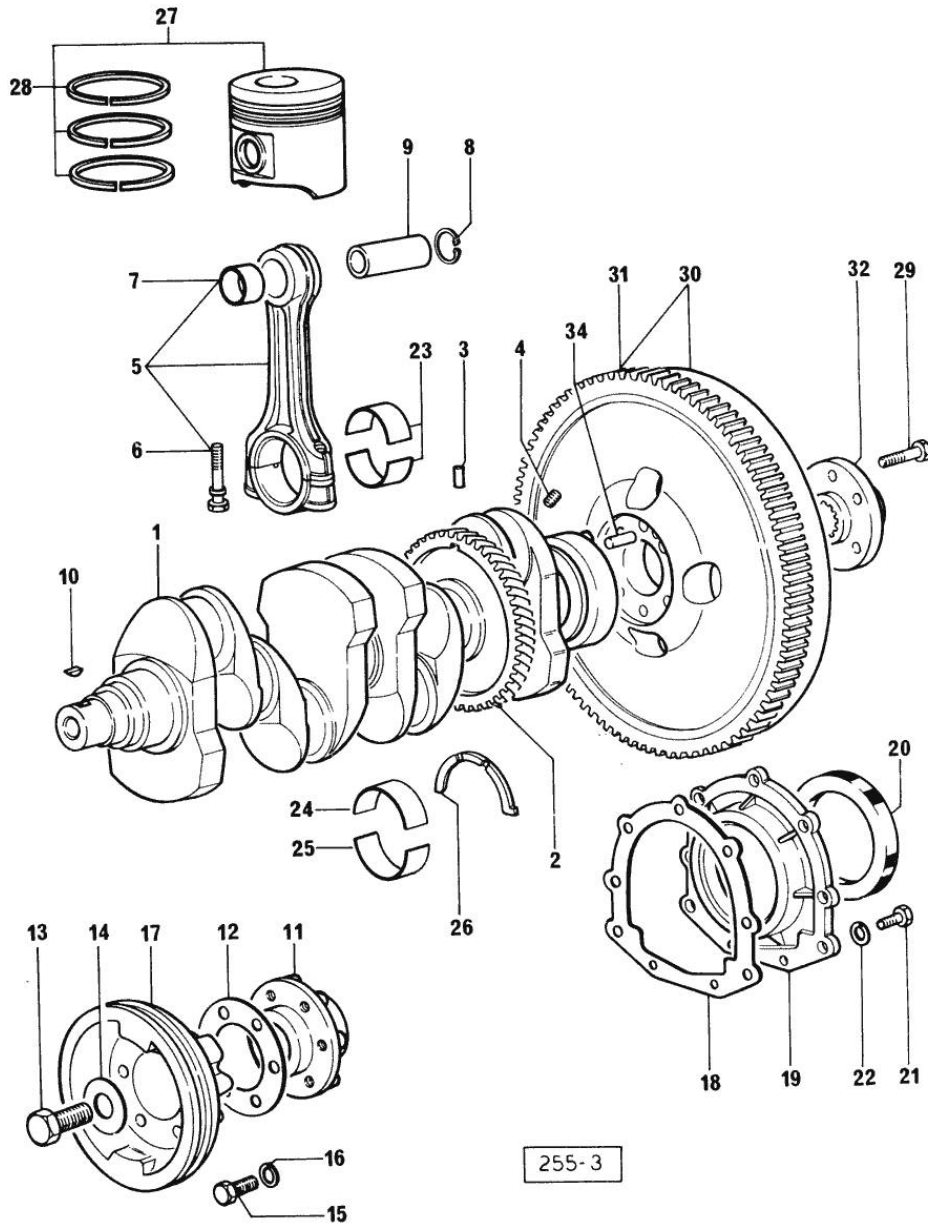

Section: ENGINE  
**CRANKSHAFT**

Fig.	P/n	QTY	Name
27	0.085.0060.6	4	complete piston X 1000.4 A
28	0.065.0052.6	4	piston ring set X 916.4 A
28	0.085.0052.6	4	piston ring set X 1000.4 A
29	2.0139.022.2	6	screw m 12 p.1.25x55
30	0.076.1247.3	1	old part number
31	0.065.1242.0	1	crown wheel Z = 123
32	0.255.2525.0/10	1	flange
34	2.1652.915.0	1	cylindrical plug 12x35

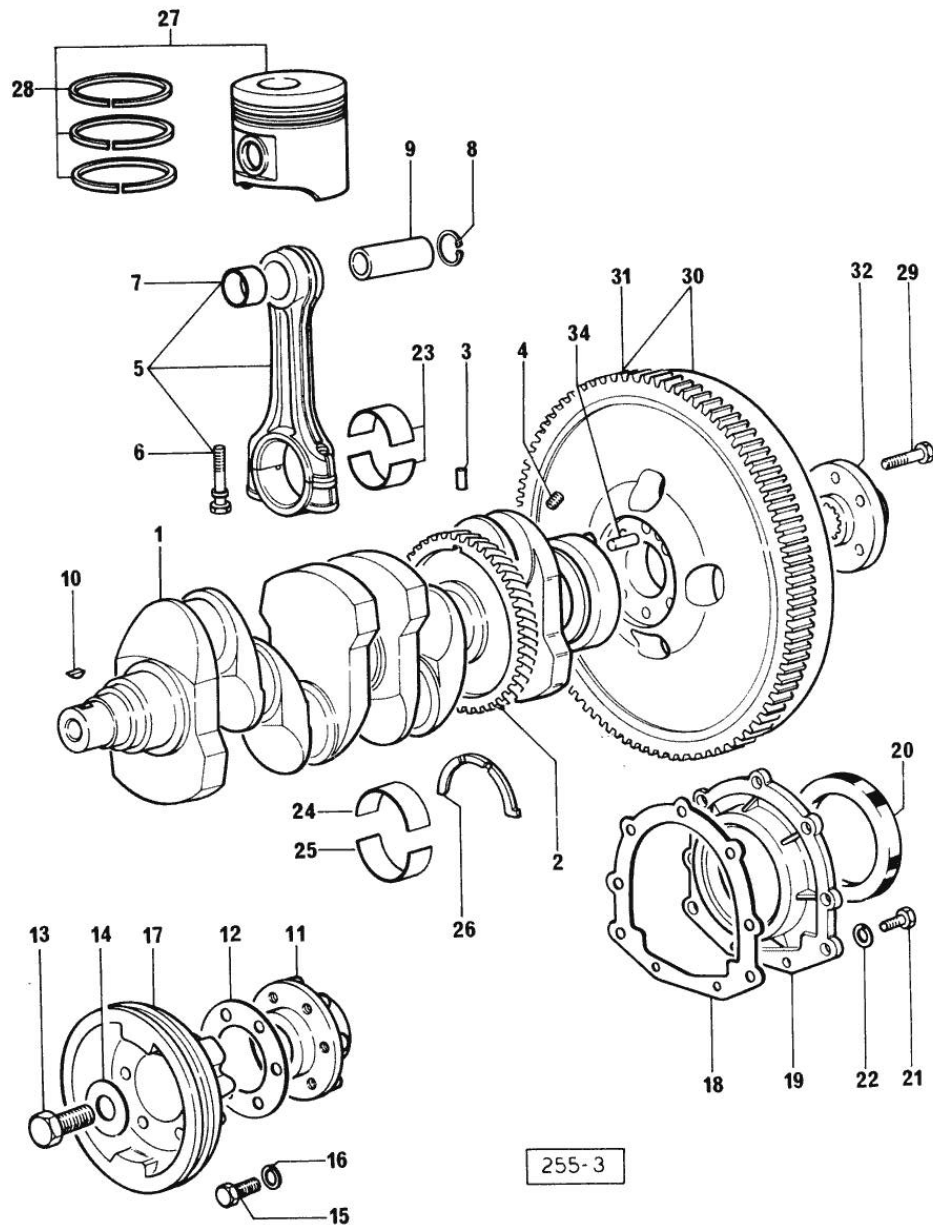

Section: ENGINE  
COUNTERWEIGHTS

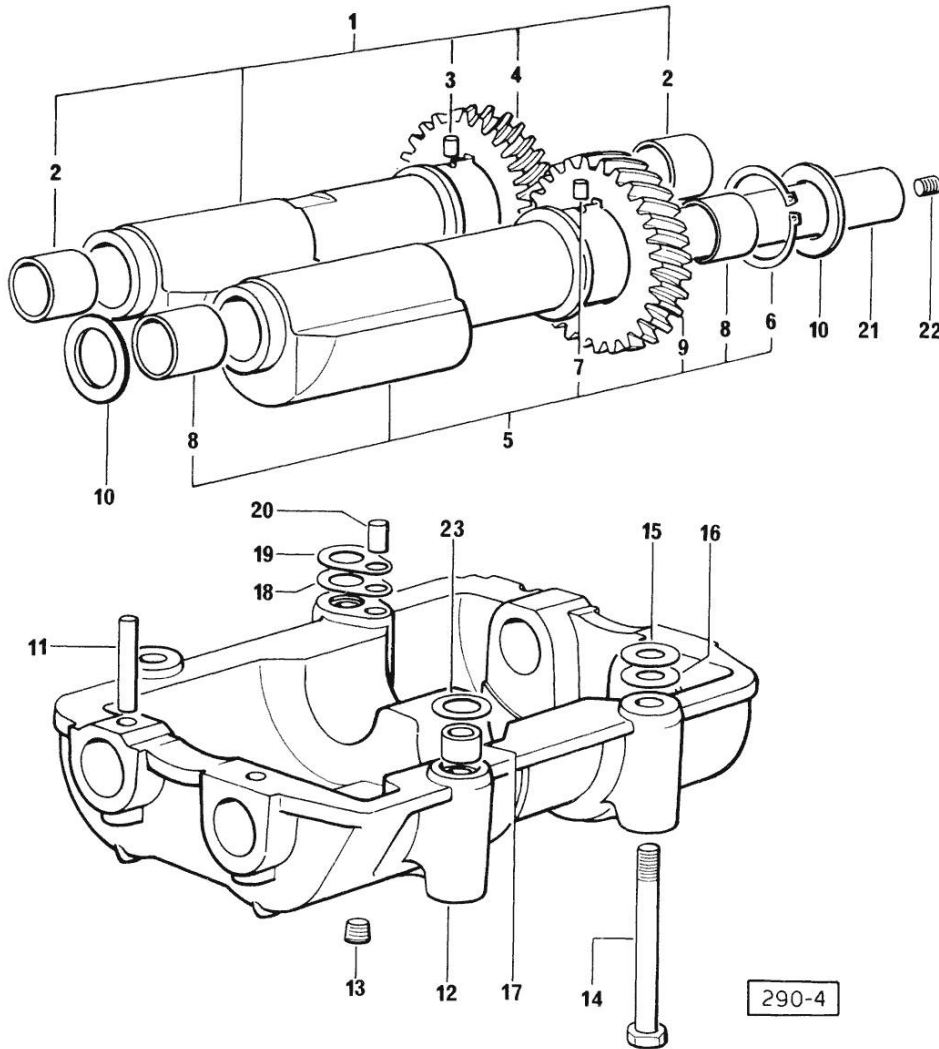

Fig.	P/n	QTY	Name
<b>Notes:</b> [EXPLORER 75 SPECIAL]			
1	0.065.1232.3/20	1	old part number X 916.4 A
1	0.086.1233.3	1	mass X 1000.4 A
2	2.1559.115.0	2	special bushing 26x30x30
3	2.1652.302.0	1	roll pin 4x6
4	0.065.1237.0	1	old part number
5	0.065.1233.3/10	1	mass
6	2.1410.018.1	1	circlip 45
7	2.1652.302.0	1	roll pin 4x6
8	2.1559.115.0	2	special bushing 26x30x30
9	0.065.1238.0	1	gear
10	2.1589.050.0/10	4	shoulder ring 26.1x38x1 X 916.4 A
10	2.1589.185.0	4	shoulder ring 26.1x34x1 X 1000.4 A
11	2.1631.717.0	2	roll pin 8 x 40
12	0.065.1231.3/20	1	old part number X 916.4 A
12	0.086.1231.3	1	old part number X 1000.4 A
13	2.3130.001.1	4	plug 1/8" gas
14	2.0112.427.2	3	screw m 12 p.1.75 x 90
15	2.1589.049.0	1	shoulder ring 12.5x26x0.3
16	2.1579.629.0	1	spacer 12.5x26x0.1
17	2.1579.626.0	2	spacer 13.2x16x11
18	2.1589.139.0	2	shoulder ring mm 0.3
19	2.1589.140.0	2	shoulder ring mm 0.1
20	2.1699.191.0	1	bush 7x10x16
21	0.065.1234.3	2	old part number
22	2.3130.001.1	2	plug 1/8" gas
23	2.1579.628.0	2	spacer 16.5x26x0.1
23	2.1589.048.0	2	shoulder ring 16.5x26x0.3

Section: ENGINE  
CAMSHAFT

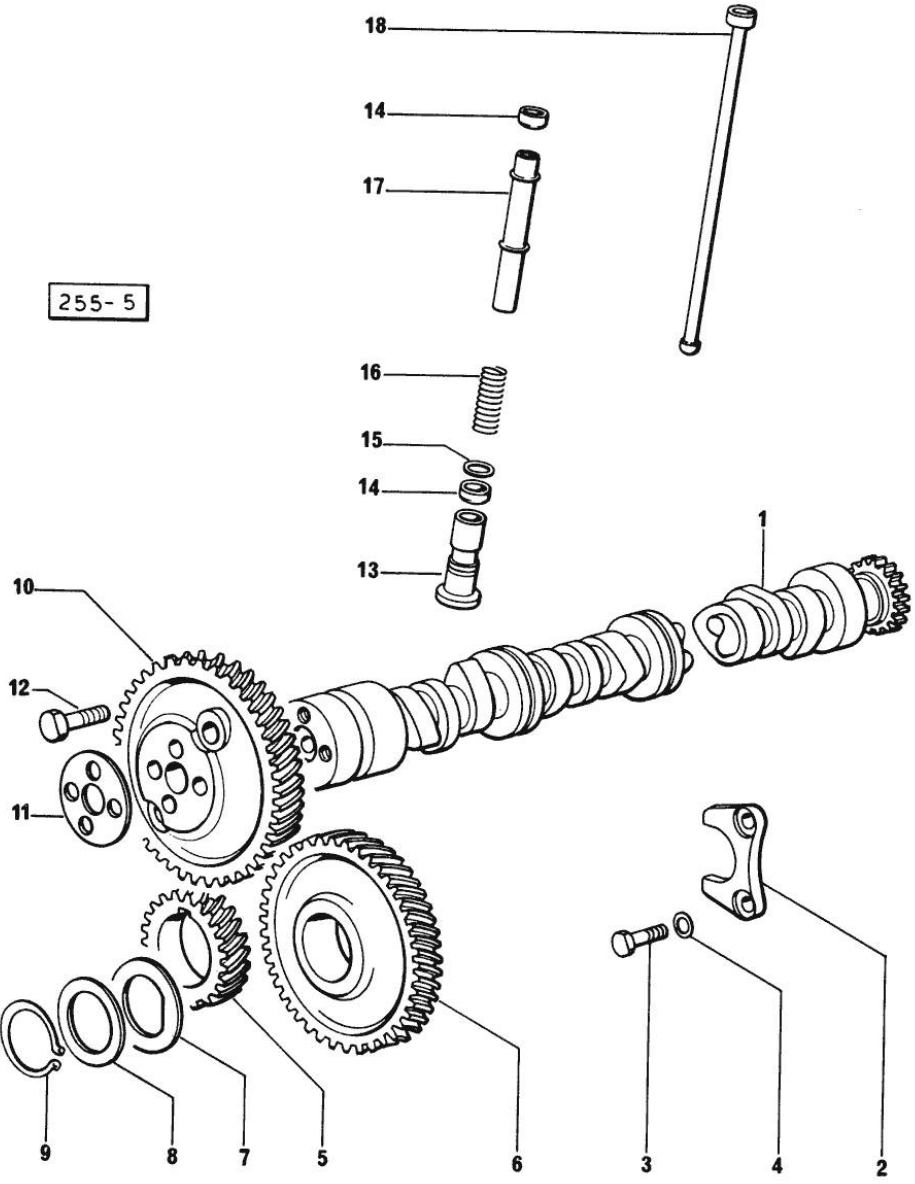

Fig.	P/n	QTY	Name
------	-----	-----	------

Notes:  
[EXPLORER 75 SPECIAL]

1	0.065.1324.0	1	gear
1	0.066.1310.3/10	1	old part number
2	0.065.1353.0	1	small plate
3	2.0312.205.2	2	screw
4	2.1480.014.1	2	washer 8
5	065.1323.0/20	1	-
6	065.1325.3/20	1	-
6	2.1559.185.0	1	special bushing
7	065.1351.0	2	-
8	0.065.1352.0	1	shim
9	2.1410.016.1	1	circlip 40
10	0.065.1354.0/10	1	gear z=58
11	0.065.1350.0	1	small disc
12	2.0132.207.2	4	screw m 10 p.1 x 25
13	0.065.1330.0	8	tappets
14	2.1569.114.0	16	gasket
15	2.1599.437.0	8	shoulder ring
16	2.4019.300.1	8	spring
17	0.065.1332.0	8	sleeve
18	0.065.1331.2	8	rod

Section: ENGINE  
CYLINDER HEAD

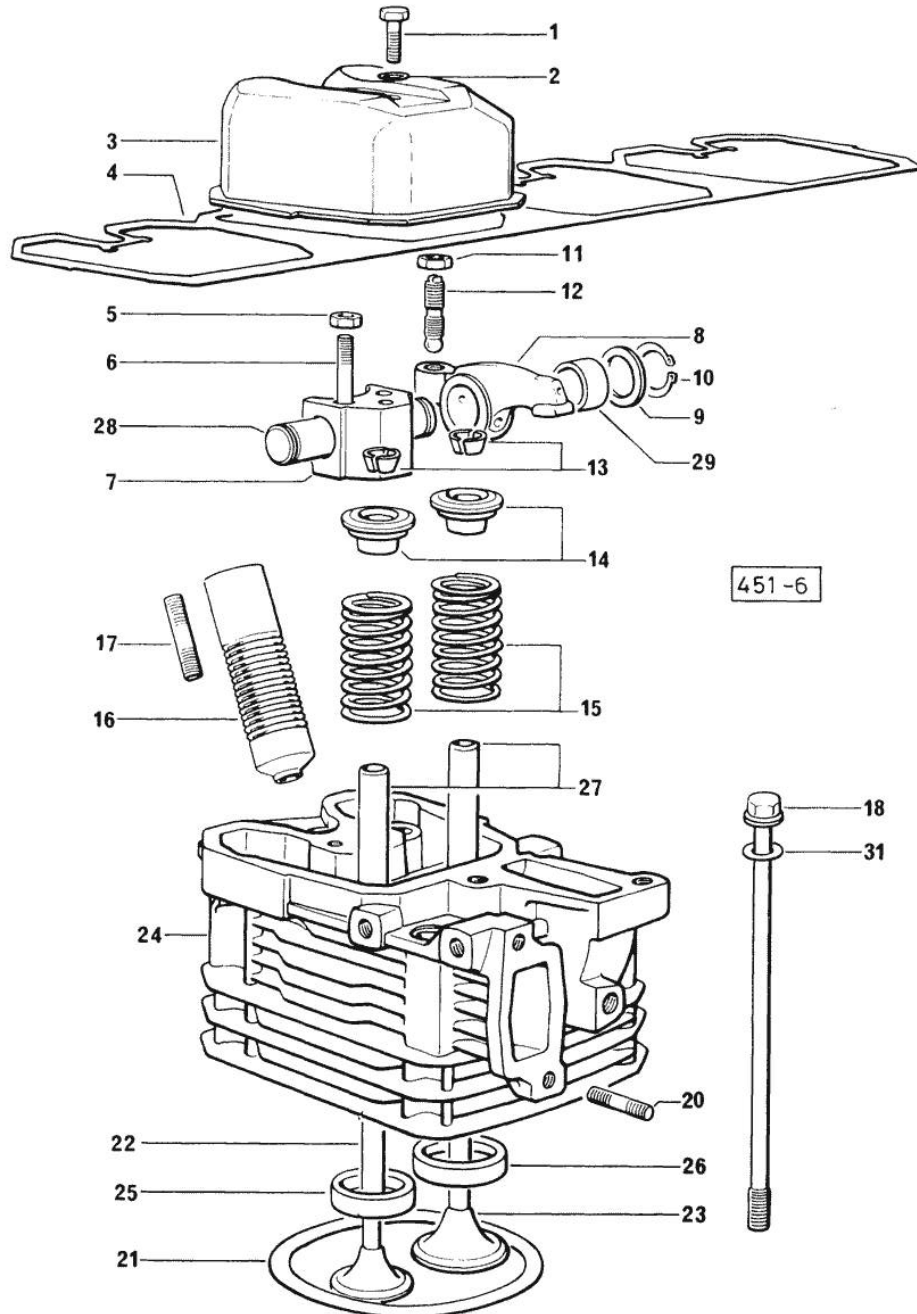
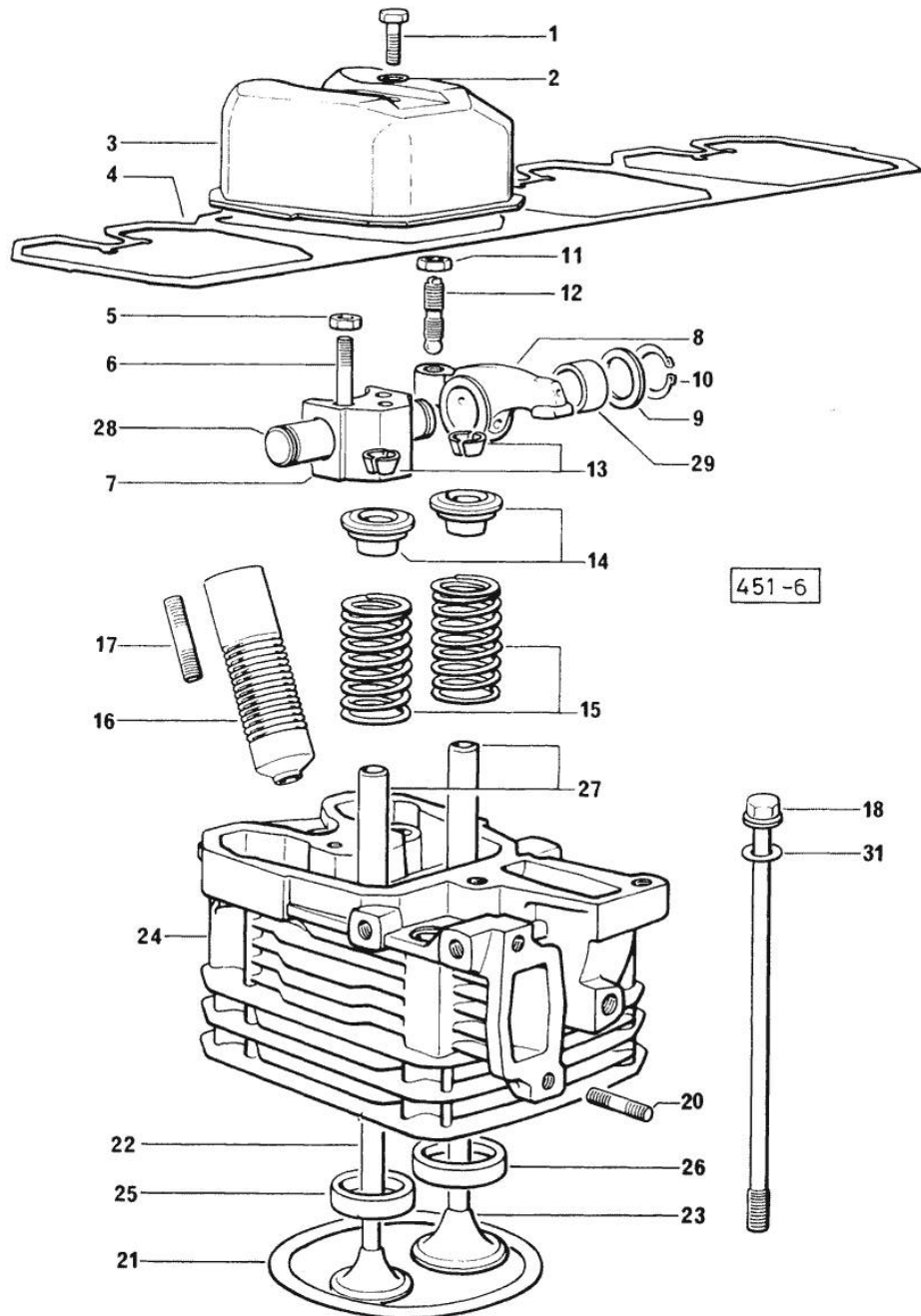

Fig.	P/n	QTY	Name
<b>Notes:</b> [EXPLORER 75 SPECIAL]			
0	0.065.0057.6	4	gasket set - FOR 1 CYLINDER VALVE GRINDING AND PISTON RINGS REPLACEMEN - X 916.4 A
0	0.085.0057.6	4	gasket set - FOR 1 CYLINDER VALVE GRINDING AND PISTON RINGS REPLACEMEN - X 1000.4 A
1	2.0112.211.2	4	screw m 8 p.1.25 x 30
2	2.1560.204.0	4	gasket
3	0.066.1440.0/10	4	small cap
4	0.065.1450.0/10	1	gasket
4	0.066.1450.0	4	tappet gasket
5	2.1011.421.2	8	nut m 10 p.1.25
6	2.0432.163.7	8	stud bolt m 10 p.1.5 / p.1.25 x 45
7	0.066.1430.0	4	support
8	0.066.1432.0	8	rocker arm
9	2.1599.432.0	8	shoulder ring
10	2.1410.055.1	8	circlip 19
11	2.1011.405.2	8	nut m 8 p.1
12	0.021.1434.0	8	screw
13	0.074.1423.0	8	conical valve cotter
14	0.066.1425.0	8	cup
15	2.4019.287.0	8	spring
16	0.065.1413.0/10	4	bush L = mm 97.1
17	2.0432.161.7	4	stud bolt m 10 p.1.5 / p.1.25 x 40
18	0.065.1443.0/10	16	screw
20	2.0432.007.7	8	stud bolt m 8 p.1.25 / p.1 x 30
21	0.085.1450.0	4	head gasket mm 0.5 -A- X 1000.4 A
21	0.085.1451.0	4	head gasket mm 0.7 -B- X 1000.4 A
21	0.085.1452.0	4	head gasket mm 1.0 -C- X 1000.4 A
21	0.085.1453.0	4	head gasket mm 0.8 -D- X 1000.4 A
21	2.1569.112.0	4	gasket X 916.4 A
22	0.066.1421.0	4	exhaust valve
23	0.066.1420.0	4	inlet valve Ø mm 9 X 916.4 A



Section: ENGINE  
CYLINDER HEAD

Fig.	P/n	QTY	Name
23	0.081.1420.0	4	inlet valve Ø mm 9 X 1000.4 A
24	0.065.1410.3/10	4	engine head X 916.4 A
24	0.081.1410.3	4	engine head X 1000.4 A
25	0.066.1427.0	4	valve seat
26	0.066.1426.0	4	valve seat X 916.4 A
26	0.078.1426.0	4	valve seat X 1000.4 A
27	0.066.1416.0	8	valve guide
28	0.066.1431.0	4	pin
29	2.1559.021.0/40	8	bushing 15x19x22
31	2.1599.434.0	16	shoulder ring



Section: ENGINE  
LUBRICATION

Fig.	P/n	QTY	Name
------	-----	-----	------

Notes:  
[EXPLORER 75 SPECIAL]

1	0.065.1510.0/20	1	oil sump
2	0.065.1550.0	1	gasket
3	2.3199.001.2	1	plug 1/2" gas
4	2.1560.054.0	1	gasket 21 x 26
5	2.0112.227.2	6	screw m 8 p.1.25 x 90
5	2.0112.235.2	3	screw m 8 p.1.25 x 130
6	2.0112.215.2	17	screw m 8 p.1.25 x 40
7	2.1470.004.2	26	lock washer 8
8	0.065.1531.3	1	tube
9	2.0112.205.2	1	screw m 8 p.1.25 x 16
10	2.1011.105.2	1	nut m 8 p.1.25
11	2.1470.004.2	2	lock washer 8
12	0.065.1538.0	1	flange
13	2.1539.040.0	1	special oil seal 21.82 x 3.53
14	2.0312.216.1	2	screw
15	2.1480.014.1	4	washer 8
16	0.077.1540.3/10	1	old part number
17	2.1539.048.0	2	special oil seal 20.35x1.78
18	0.066.1513.2	1	dipstick
19	2.1539.065.0	2	special oil seal 8.73 x 1.78
20	0.066.1551.0	1	spacer
23	0.044.1567.0	1	oil filter element
24	2.3339.307.1/20	1	pipe fitting
25	2.3339.353.2	1	pipe fitting
26	2.1560.014.0	1	washer 18.2 x 24
27	2.0399.125.2/10	2	screw m 8 x 55

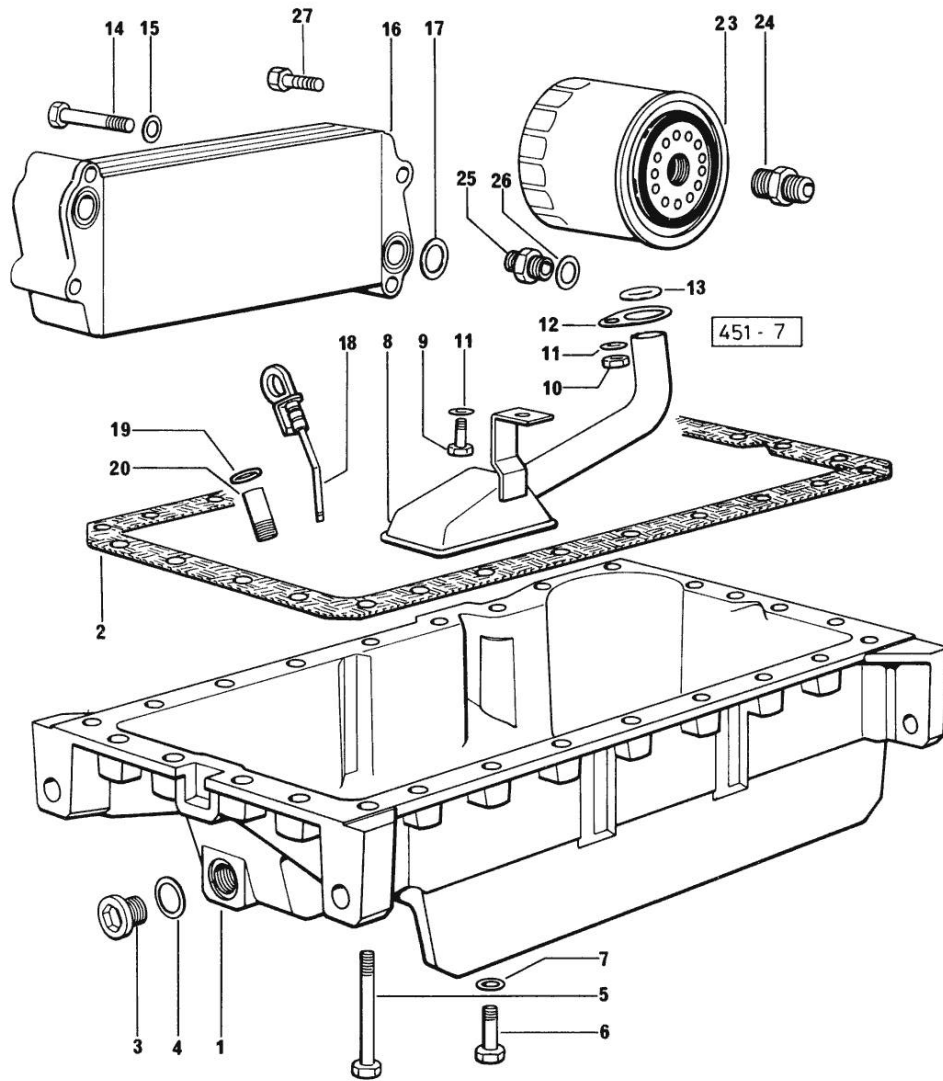

Section: ENGINE  
LUBRICATION

Fig.	P/n	QTY	Name
------	-----	-----	------

Notes:  
[EXPLORER 75 SPECIAL]

1	0.065.1510.0/20	1	oil sump
2	0.065.1550.0	1	gasket
3	2.3199.001.2	1	plug 1/2" gas
4	2.1560.054.0	1	gasket 21 x 26
5	2.0112.227.2	6	screw m 8 p.1.25 x 90
5	2.0112.235.2	3	screw m 8 p.1.25 x 130
6	2.0112.215.2	17	screw m 8 p.1.25 x 40
7	2.1470.004.2	26	lock washer 8
8	0.065.1531.3	1	tube
9	2.0112.205.2	1	screw m 8 p.1.25 x 16
10	2.1011.105.2	1	nut m 8 p.1.25
11	2.1470.004.2	2	lock washer 8
12	0.065.1538.0	1	flange
13	2.1539.040.0	1	special oil seal 21.82 x 3.53
14	2.0312.216.1	2	screw
15	2.1310.004.2	4	flat washer 8.4x17
16	0.077.1540.3/10	1	old part number
17	2.1539.048.0	2	special oil seal 20.35x1.78
18	0.066.1513.2/10	1	dipstick mm 106 - WITH SPACER
18	0.086.1513.2	1	dipstick WITHOUT SPACER
19	2.1539.065.0	2	special oil seal 8.73 x 1.78
20	0.066.1551.0	1	spacer
23	0.044.1567.0	1	oil filter element
24	2.3339.307.1/20	1	pipe fitting
25	2.3339.353.2	1	pipe fitting
26	2.1560.014.0	1	washer 18.2 x 24
27	2.0399.125.2/10	2	screw m 8 x 55

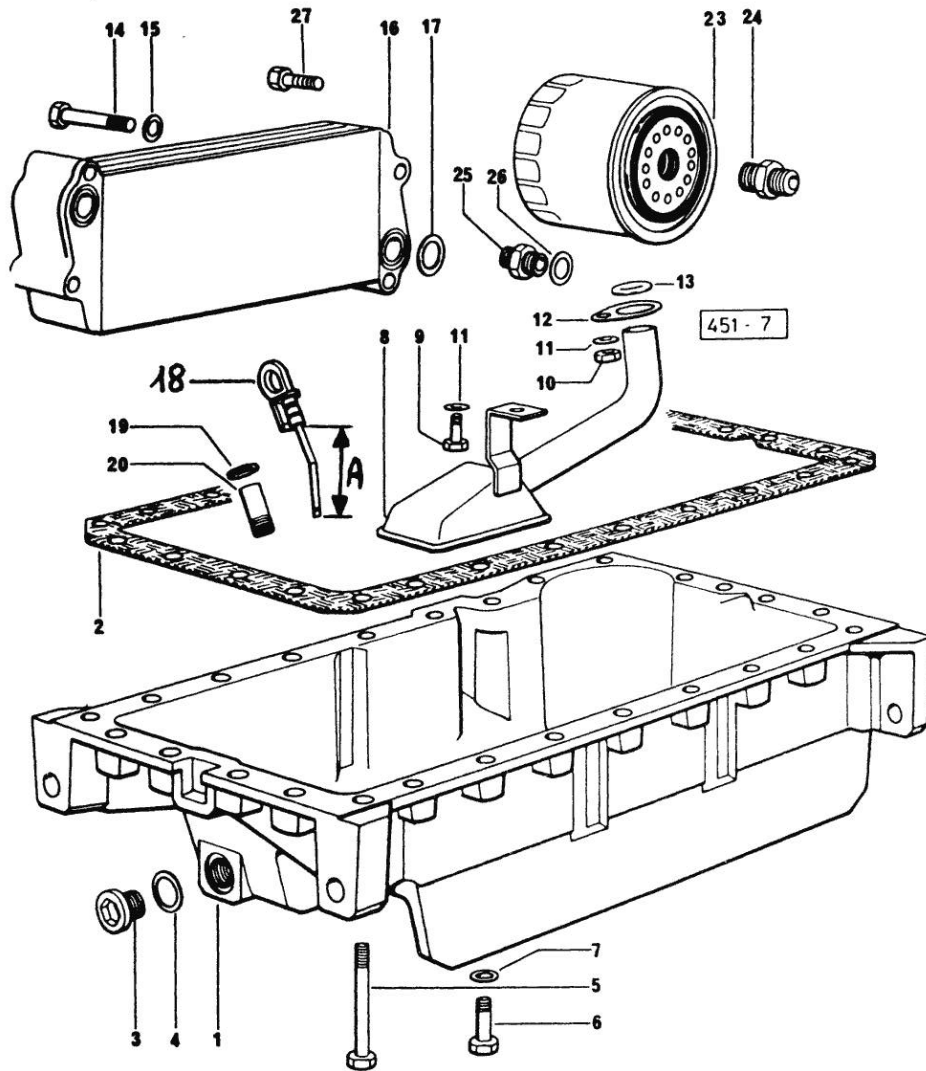

Thank you so much for reading.  
Please click the “Buy Now!”  
button below to download the  
complete manual.



After you pay.

You can download the most  
perfect and complete manual in  
the world immediately.

Our support email:

[ebooklibonline@outlook.com](mailto:ebooklibonline@outlook.com)