

Section: ENGINE
CRANKCASE

Fig.	P/n	QTY	Name
------	-----	-----	------

Notes:
 [EXPLORER 90 Special -> 2500]

1	0.087.0050.6/10		gasket set - FOR ENGINE MOUNTING
2	2.0112.511.2	8	screw m 14 p.2 x 30
3	0.066.1130.0/20	1	flange
8	2.1099.108.2	4	special nut m 10 p.1
9	2.1560.006.0	8	gasket 10.2 x 16
10	0.086.1550.2	4	sprayer nozzle
11	0.065.1160.3/20	4	valve
12	2.1539.047.0	1	special oil seal 26.7x1.78
13	2.3199.405.2	1	plug m 28 p.1.5
16	2.0432.003.7	12	stud bolt m 8 p.1.25 / p.1 x 20
19	2.1539.130.0/10	4	special oil seal 117.07x3.53
20	0.007.0762.0/50	4	engine cylinder
25	0.066.1152.0/10	4	gasket
26	0.007.1140.6/10	1	crankcase
27	0.065.1112.7	1	support
28	2.1699.165.0	1	bush 12.3x15x16
29	0.065.1116.3	1	support
30	2.1699.165.0	1	bush 12.3x15x16
31	0.066.1151.0	1	pin
32	0.065.1141.0	1	special bushing 59X55X30
33	0.065.1140.0	4	special bushing 59X55X20
34	2.3179.012.0	1	plug 60
35	2.3130.001.1	11	plug 1/8" gas
36	2.3130.002.1	2	plug 1/4" gas
37	2.3130.003.1	7	plug 3/8" gas
38	2.3199.092.0	4	plug 8 x 12
41	2.1324.011.0	1	plug
42	0.065.1117.0	10	screw m 12 x 100
43	0.065.1114.0/10	3	support
44	2.1651.912.0	2	cylindrical plug 12x28
45	2.1651.917.0	1	cylindrical plug 12x40
46	2.0432.255.7	2	stud bolt m 12 p.1.75-1.25x25
52	2.1560.017.0	1	gasket 22.2 x 27
53	2.3120.002.4	1	plug m 22 x 1.5

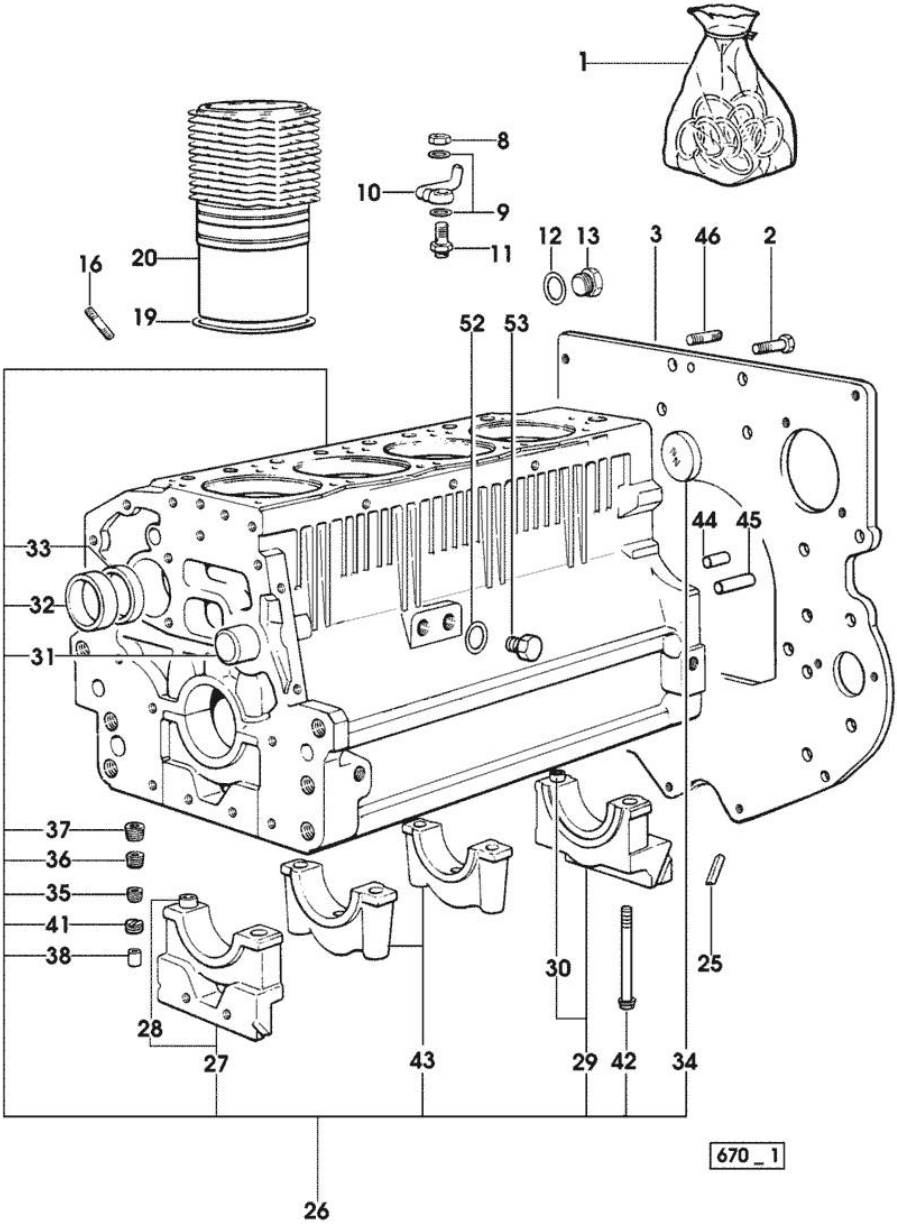

Section: ENGINE
TIMING CASE

Fig.	P/n	QTY	Name
------	-----	-----	------

Notes:
[EXPLORER 90 Special -> 2500]

1	0.007.1262.3/50	1	guard
2	0.007.1271.0/10	1	small column m 8 p.1.25 / L = mm 60
3	0.007.1272.0/10	2	small column m 8 p.1.25 / L = mm 50
5	2.1310.004.2	3	flat washer 8.4x17
7	2.0112.205.2	3	screw m 8 p.1.25 x 16

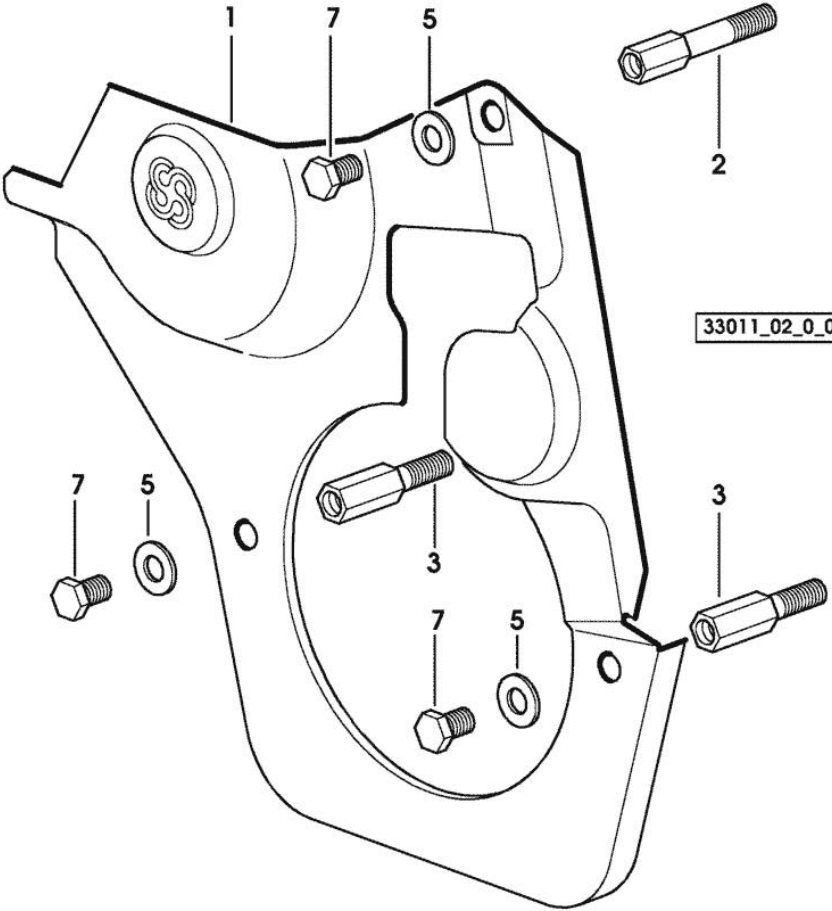

Section: ENGINE
TIMING CASE

Fig.	P/n	QTY	Name
------	-----	-----	------

Notes:
[EXPLORER 90 Special -> 2500]

1	0.065.1132.0/60	1	guard
2	0.065.1150.0/30	1	gasket
3	0.065.1152.0	1	gasket
4	0.065.1151.0	1	cover
5	2.1470.004.2	4	lock washer 8
6	2.0112.205.2	2	screw m 8 p.1.25 x 16
7	2.0432.003.7	2	stud bolt m 8 p.1.25 / p.1 x 20
8	2.1011.405.2	2	nut m 8 p.1
9	2.0312.208.2	8	screw m 8 p.1.25 x 25
10	2.1480.014.1	15	washer 8
11	2.0432.003.7	2	stud bolt m 8 p.1.25 / p.1 x 20
13	2.0312.219.2	4	screw m 8 p.1.25x65
14	2.1529.141.0	1	special oil seal
15	2.0312.214.2	3	screw m 8 p.1.25 x 40

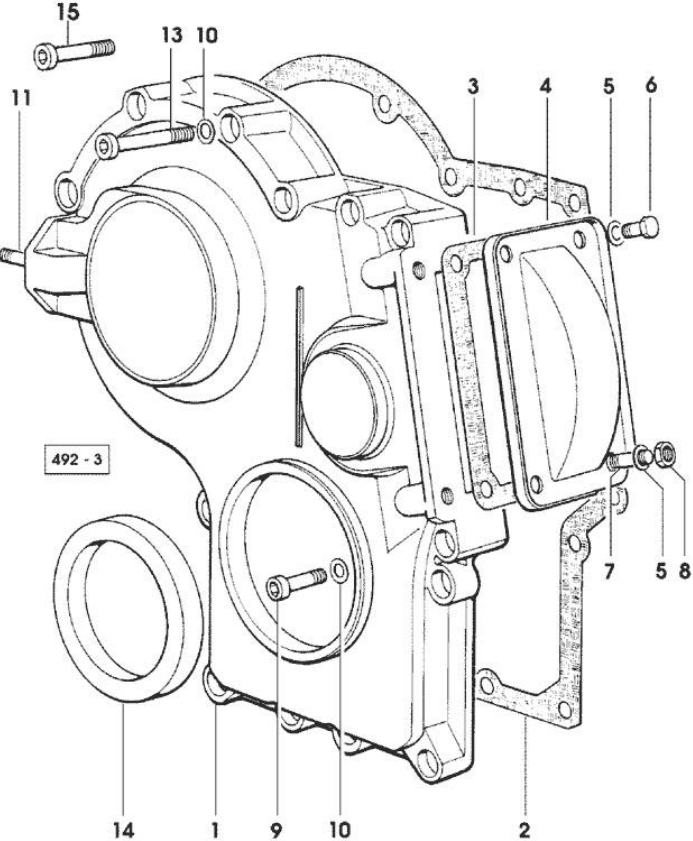

Section: ENGINE

CRANKSHAFT

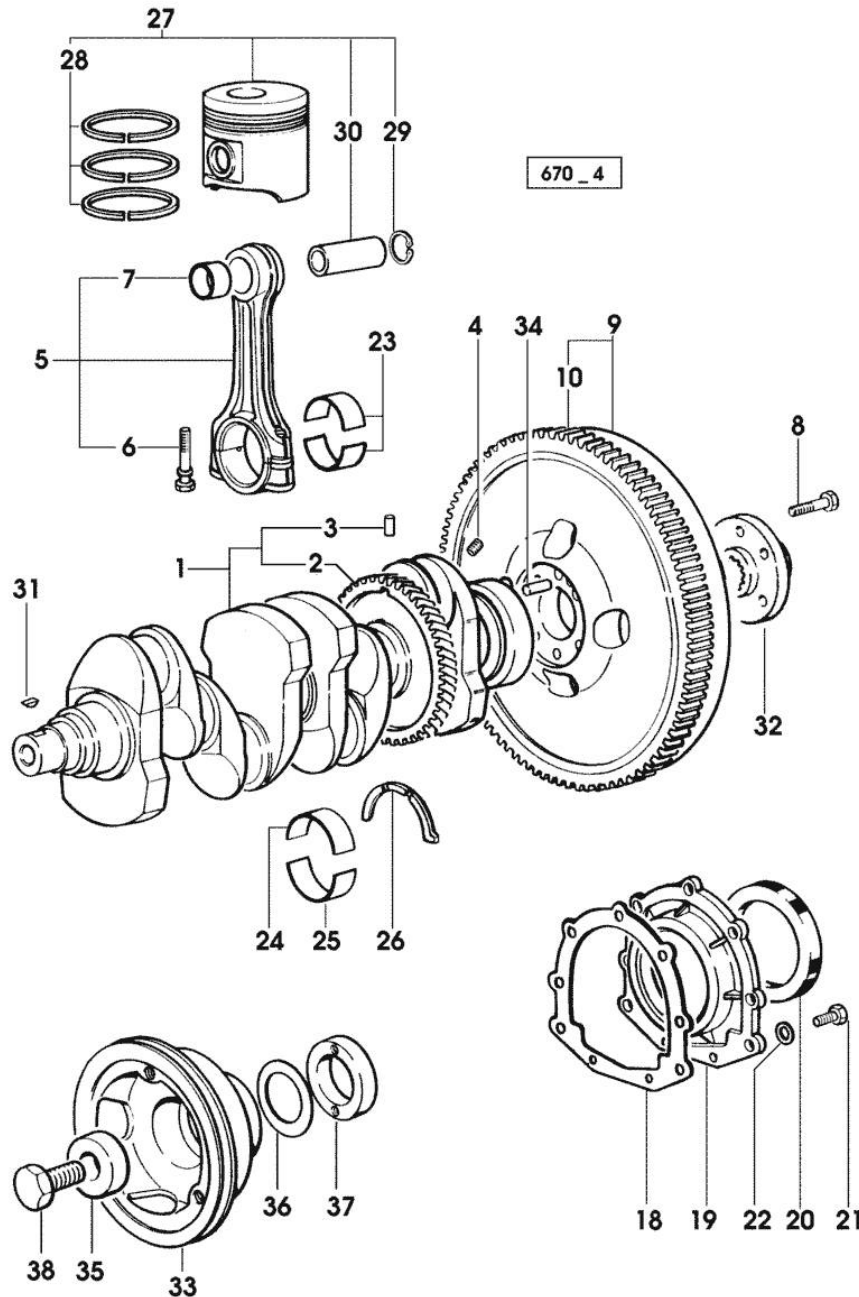

Notes:

[EXPLORER 90 Special -> 2500]

Fig.	P/n	QTY	Name
1	0.086.1210.3/30	1	crankshaft
2	0.065.1211.0/10	1	crown wheel
3	2.1630.608.0	1	pin 6x16
4	2.3130.001.1	4	plug 1/8" gas
5	0.078.1220.3/30	4	engine connecting rod
6	2.0399.213.0	8	screw m 12 p.1.25x61.5
7	2.1559.114.0/10	4	special bushing
8	2.0139.022.2	6	screw m 12 p.1.25x55
9	0.007.1702.3/30	1	flywheel
			-> 15593 X 80HP
			- FOR 80HP LP WITH 385 mm DIAMETER FLYWHEEL
			-> 2975 X 90HP
			-> 1076 X 90HP LOW PROFILE
9	0.008.4049.3	1	flywheel mm 373
			15592 <- X 80HP
			- FOR 80HP LP WITH 373 mm DIAMETER FLYWHEEL
			2974 <- X 90HP
			1075 <- X 90HP LOW PROFILE
9	0.076.1247.3/20	1	flywheel
			- X 70HP
10	0.065.1242.0	1	crown wheel Z = 123
18	0.065.1254.0/20	1	gasket
19	0.007.1711.0/10	1	cover
20	2.1529.073.0	1	special oil seal 110x130x13
21	2.0112.207.2	9	screw m 8 p 1.25 x 20
22	2.1475.002.2	9	conical washer 8
23	0.065.1225.0	8	con.rod half bushing STANDARD - A = 28.75 -> 29.00
23	0.065.1225.7		con.rod half bushing - mm 0.25
23	0.065.1225.8		con.rod half bushing - mm 0.50
24	0.065.1215.0	5	main half bushing STANDARD
24	0.065.1215.7		main half bushing - mm 0.25
24	0.065.1215.8		main half bushing - mm 0.50
25	0.065.1216.0	5	main half bushing
25	0.065.1216.7		main half bushing - mm 0.25
25	0.065.1216.8		main half bushing - mm 0.50
26	0.065.1218.0	4	shim STANDARD
26	0.065.1218.7		shim + mm 0.10
26	0.065.1218.8		shim + mm 0.15
27	0.086.0060.6/30	4	complete piston
			- X 70HP - 80HP
27	0.338.0060.6/20	4	complete piston

Section: ENGINE
CRANKSHAFT

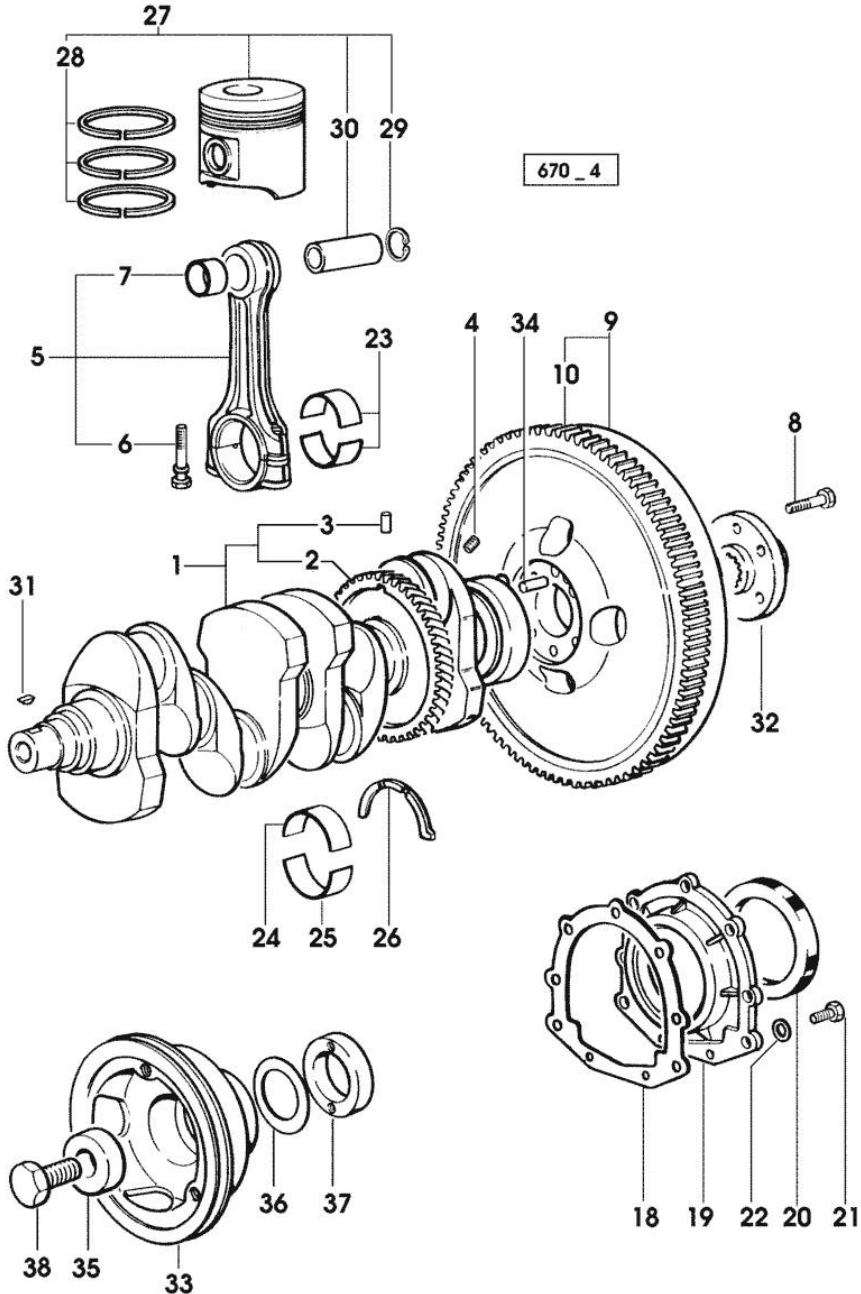

Fig.	P/n	QTY	Name
27	0.379.0060.6	4	- X 90HP complete piston
27	0.381.0060.6	4	- X 70HP - 80HP EXPORT U.S.A. complete piston
28	0.086.0052.6/10	4	- X 90HP - EXPORT U.S.A. piston ring set
28	0.338.0052.6/10	4	- X 70HP - 80HP piston ring set
29	2.1411.014.1	8	- X 90HP circlip 35
30	0.078.1236.0	4	piston pin Ø 18 / Ø 35 / L = mm 86
31	2.1720.006.0	1	key 4x6.5
32	0.008.5543.0	1	flange
32	0.255.2525.0/10	1	- X 80HP - 90HP flange
33	0.007.1330.0/30	1	- X 70HP pulley
34	2.1652.915.0	1	cylindrical plug 12x35
35	2.1599.524.7	1	washer 21x60x12
36	2.1589.189.0	3	shoulder ring mm 1.00
37	0.085.1248.0/10	1	hub
38	2.0399.144.7/10	1	screw m 20 p.1.5x51

Section: ENGINE
COUNTERWEIGHTS

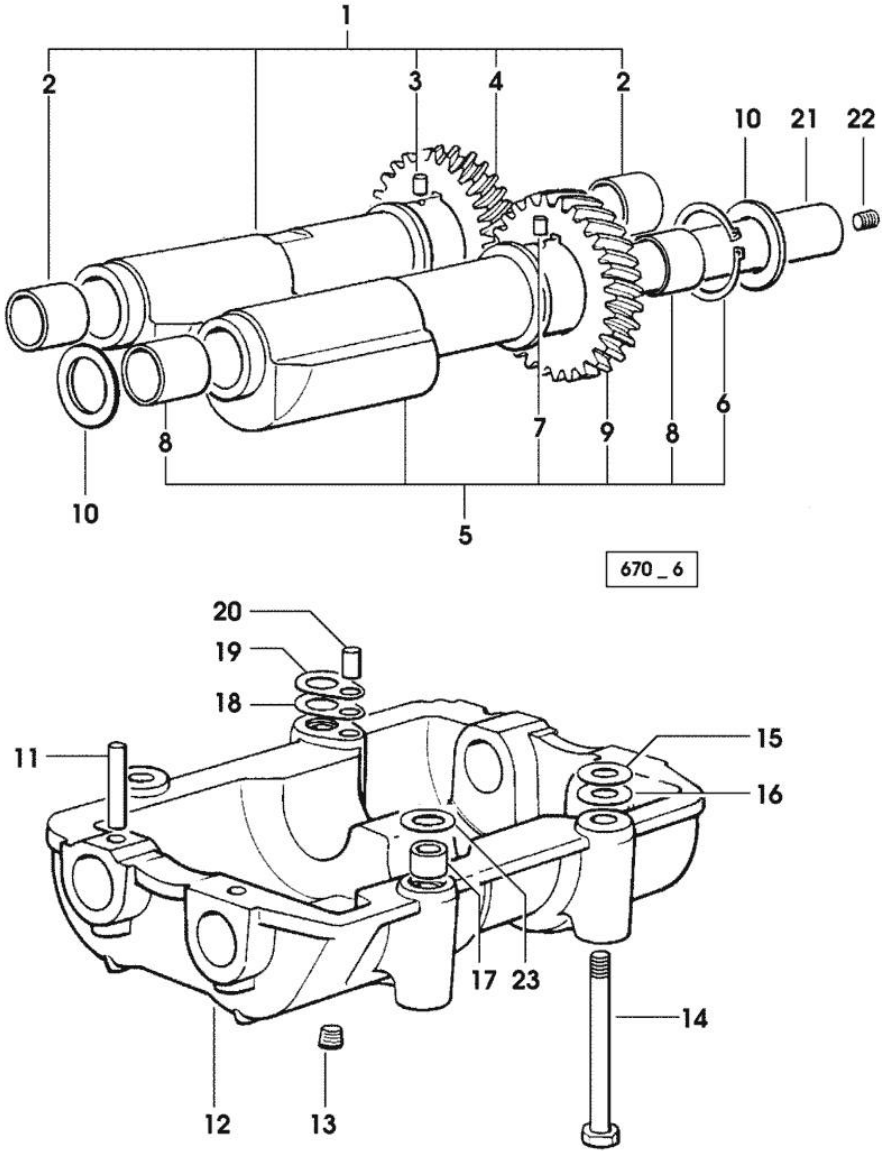

Fig.	P/n	QTY	Name
------	-----	-----	------

Notes:
 [EXPLORER 90 Special -> 2500]

1	0.086.1233.3/30	1	mass sx/lh/li
2	2.1559.115.0	2	special bushing 26x30x30
3	2.1652.302.0	1	roll pin 4x6
4	0.000.0000.1		cannot be supplied
5	0.065.1233.3/30	1	mass dx/rh/re
6	2.1410.018.1	1	circlip 45
7	2.1652.302.0	1	roll pin 4x6
8	2.1559.115.0	2	special bushing 26x30x30
9	0.000.0000.1		cannot be supplied
10	2.1589.185.0	4	shoulder ring 26.1x34x1
11	2.1631.717.0	2	roll pin 8 x 40
12	0.086.1231.0/10	1	box
13	2.3130.001.1	4	plug 1/8" gas
14	2.0139.028.2	4	screw m 12
15	2.1579.629.0		spacer 12.5x26x0.1
16	2.1589.049.0		shoulder ring 12.5x26x0.3
17	2.1579.626.0	2	spacer 13.2x16x11
18	2.1589.140.0		shoulder ring mm 0.1
19	2.1589.139.0		shoulder ring mm 0.3
20	2.1699.191.0	1	bush 7x10x16
21	0.065.1234.0/10	2	shaft
22	2.3130.001.1	1	plug 1/8" gas
23	2.1579.628.0		spacer 16.5x26x0.1
23	2.1589.048.0		shoulder ring 16.5x26x0.3

Section: ENGINE
CAMSHAFT

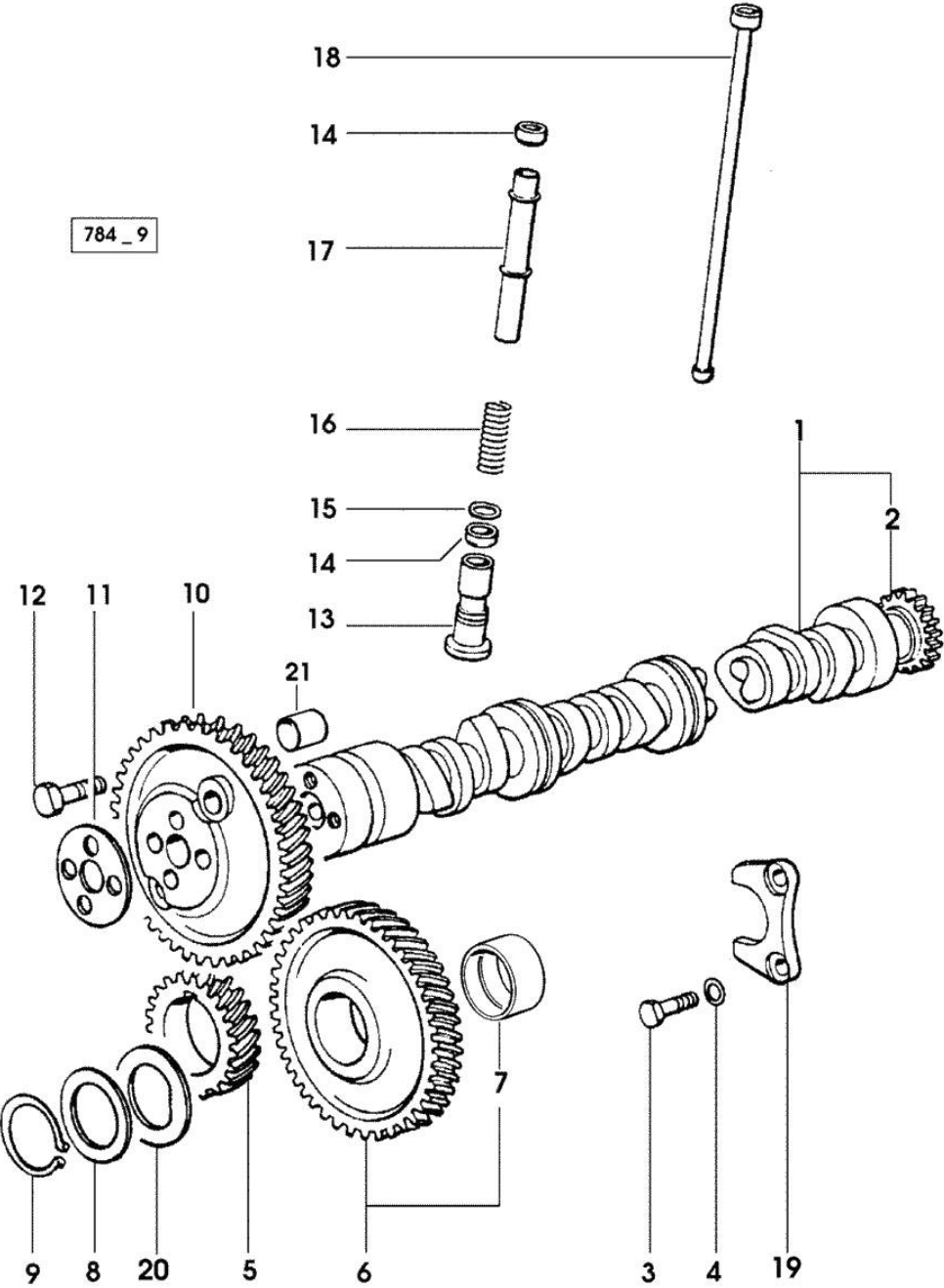

Fig.	P/n	QTY	Name
Notes:			
[EXPLORER 90 Special -> 2500]			
1	0.007.1712.3/10	1	camshaft - EXPORT U.S.A.
1	0.066.1310.3/40	1	camshaft
2	0.065.1324.0/10	1	gear Z = 32
3	2.0312.206.2	2	screw m 8 p 1.25 x 20
4	2.1480.014.1	2	washer 8
5	0.065.1323.0/30	1	gear Z = 29
6	0.007.1177.3/10		gear z = 57 - WITH RED IDENTIFICATION STAMP
6	0.007.1178.3/10		gear z = 57 - WITH YELLOW IDENTIFICATION STAMP
6	0.007.1179.3/10		gear z = 57 - WITH GREEN IDENTIFICATION STAMP
7	2.1559.185.0/10	1	bushing
8	0.065.1352.0	1	shim
9	2.1410.016.1	1	circlip 40
10	0.065.1354.0/20	1	gear z=58
11	0.065.1350.0	1	small disc
12	2.0132.207.2	4	screw m 10 p.1 x 25
13	0.065.1330.0	8	tappets
14	2.1569.114.0/10	16	gasket 14x18.5x8
15	2.1599.437.0	8	shoulder ring
16	2.4019.300.1/10	8	spring 18.5x52x2
17	0.065.1332.0	8	sleeve
18	0.065.1331.2	8	rod
19	0.065.1353.0	1	small plate
20	0.065.1351.0	2	shoulder ring
21	2.1559.398.0	1	bushing 10.5x13x12

Section: ENGINE
CYLINDER HEAD

Fig.	P/n	QTY	Name
------	-----	-----	------

Notes:

[EXPLORER 90 Special -> 2500]

1	2.0399.130.2/10	4	screw m 8x36x44
2	2.1569.170.0/10	4	gasket 8.2 x 14
3	0.007.1139.0/10	4	small cap
4	0.065.1450.0/30	1	tappet gasket
5	2.1011.421.2	8	nut m 10 p.1.25
6	2.0432.163.7	8	stud bolt m 10 p.1.5 / p.1.25 x 45
7	0.066.1430.0/10	4	support
8	0.066.1432.3	8	rocker arm
9	2.1559.021.0/40	8	bushing 15x19x22
10	2.1410.055.1	8	circlip 19
11	2.1011.405.2	8	nut m 8 p.1
12	0.021.1434.0	8	screw
13	0.074.1423.0	16	conical valve cotter
14	0.066.1425.0	8	cup
15	2.4019.287.0	8	spring
17	2.0432.161.7	4	stud bolt m 10 p.1.5 / p.1.25 x 40
18	0.065.1443.0/20	16	screw
21	0.085.1450.0		head gasket mm 0.5 -A-
21	0.085.1451.0		head gasket mm 0.7 -B-
21	0.085.1452.0		head gasket mm 1.0 -C-
21	0.085.1453.0		head gasket mm 0.8 -D-
22	0.010.6022.0	4	exhaust valve mm 39.1 / Ø mm 9 - X 90HP -> (...) = B
22	0.066.1421.0	4	exhaust valve - X 70HP - 80HP - X 90HP (...) <= A
23	0.010.6016.0	4	inlet valve mm 43.63 / Ø mm 9 - X 70HP - 80HP
23	0.010.6017.0	4	inlet valve mm 43.63 / Ø mm 9 - X 90HP -> (...) = B
23	0.081.1420.0	4	inlet valve Ø mm 9 - X 90HP (...) <= A
24	0.007.1110.3/50	4	engine head - X 70HP - 80HP - X 90HP (...) <= A
24	0.007.1359.3/50	4	engine head - X 90HP -> (...) = B
25	0.066.1427.0	4	valve seat
26	0.078.1426.0	4	valve seat
27	0.007.1779.0/10	8	valve guide
28	0.066.1431.0	4	pin

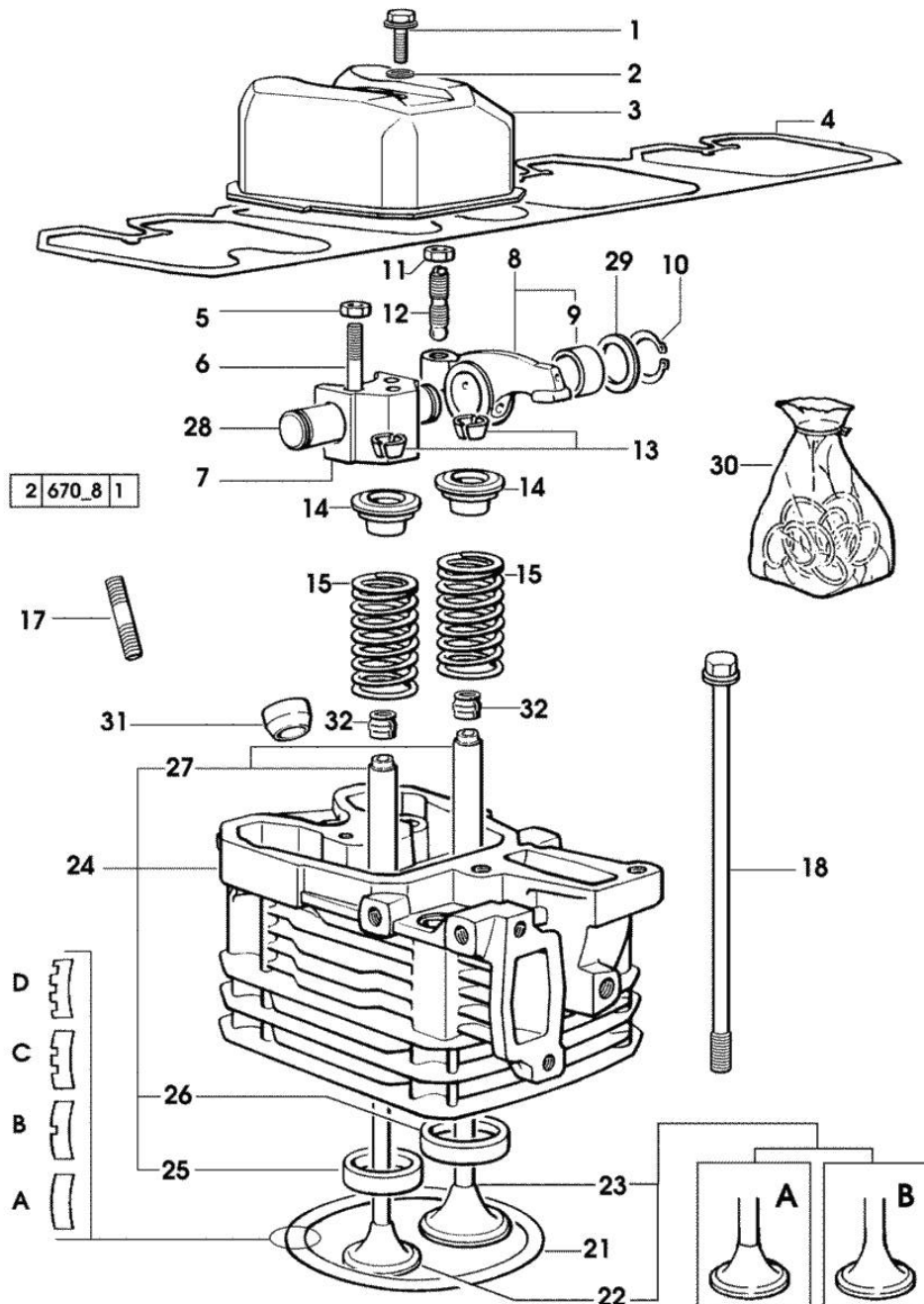

Section: ENGINE
CYLINDER HEAD

Fig.	P/n	QTY	Name
29	2.1599.432.0	8	shoulder ring
30	0.085.0057.6/10		gasket set - FOR 1 CYLINDER VALVE GRINDING AND PISTON RINGS REPLACEMENT
31	0.007.1122.0/10	4	bush L = mm 6.4
32	2.1519.117.0	8	special oil seal

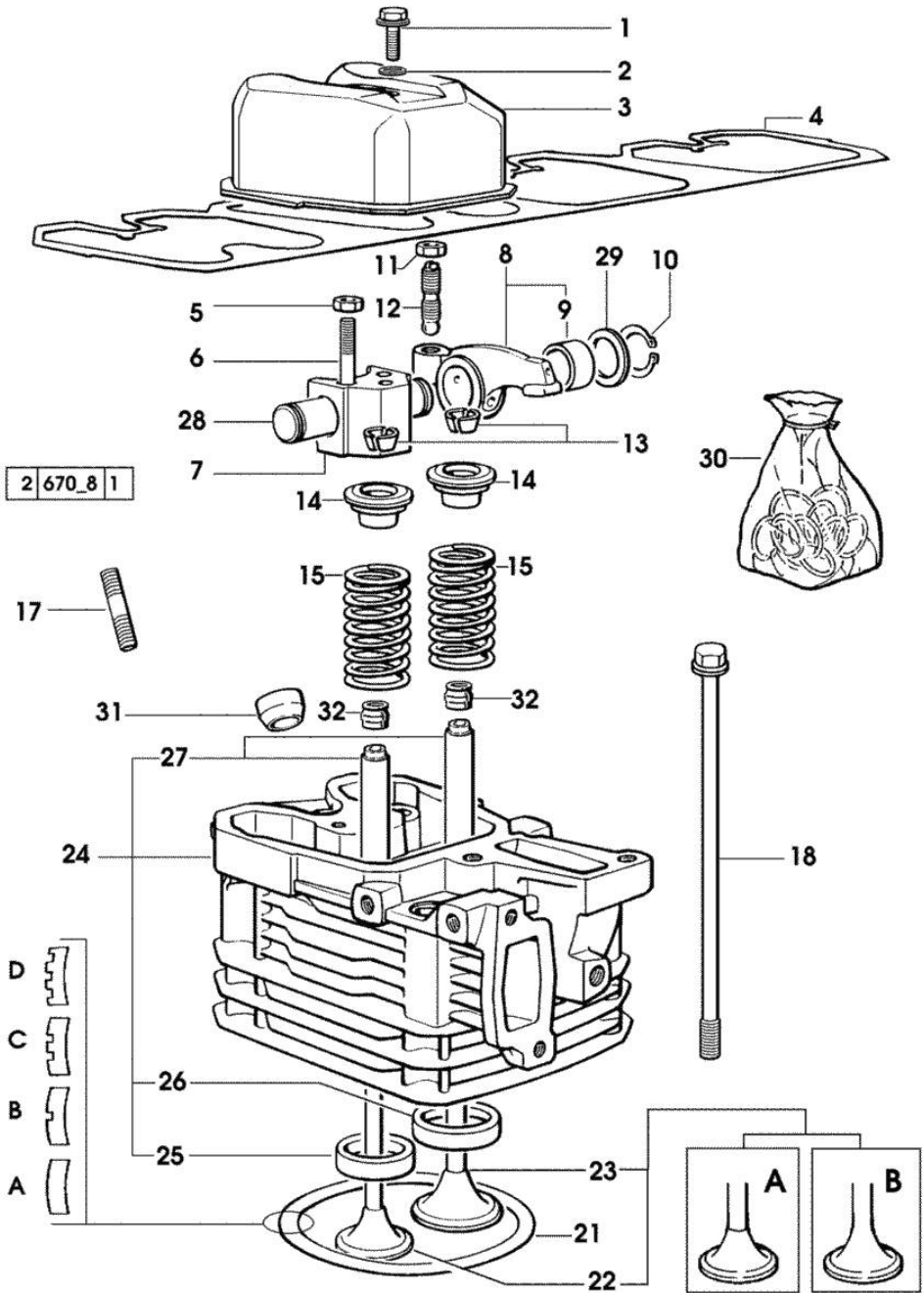

Section: ENGINE
LUBRICATION

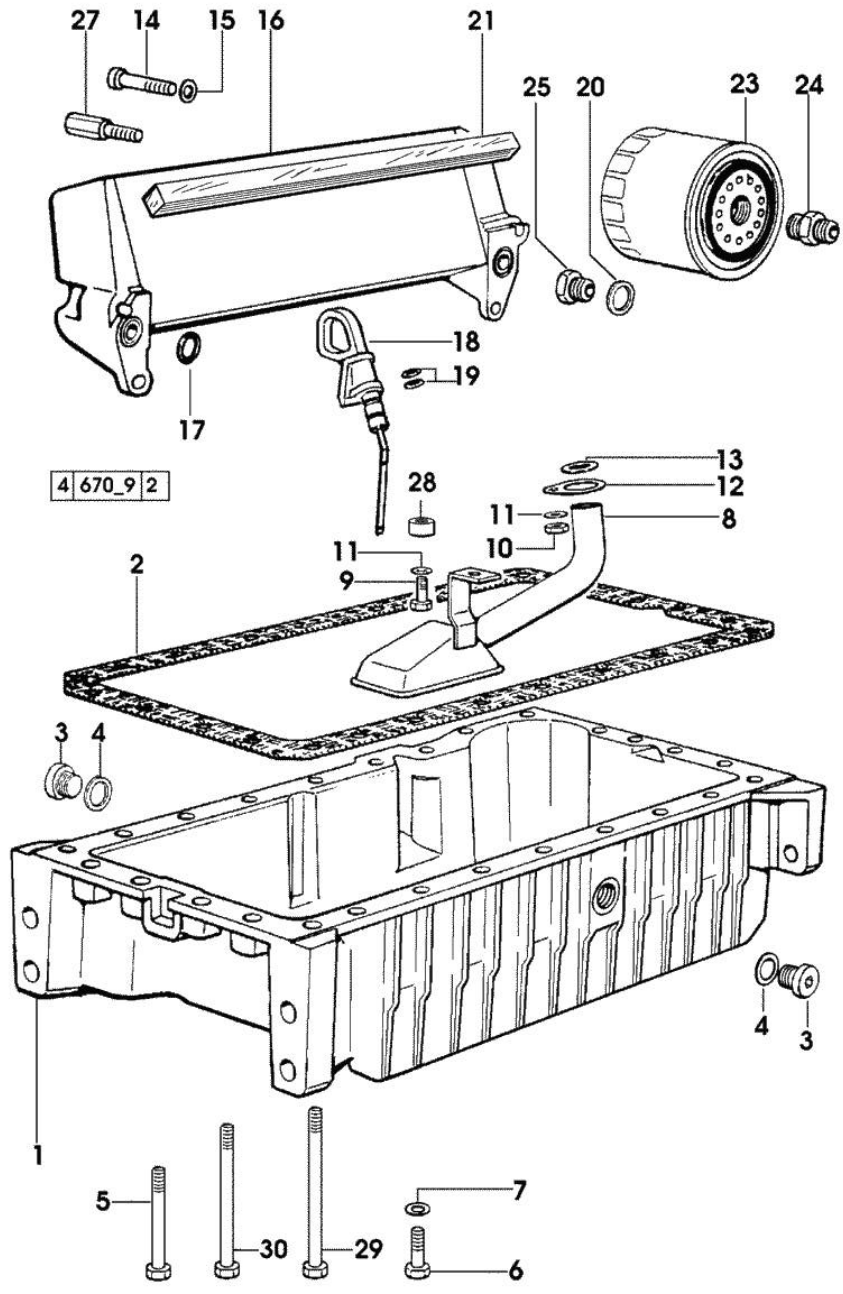
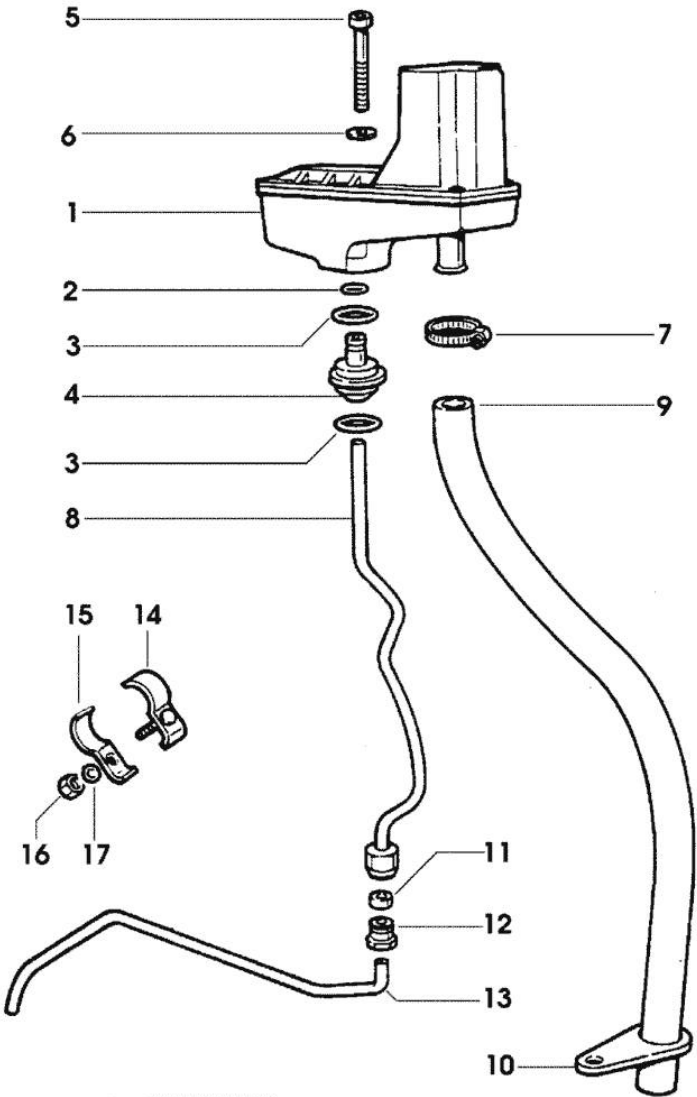

Fig.	P/n	QTY	Name
------	-----	-----	------

Notes:
[EXPLORER 90 Special -> 2500]

1	0.007.1277.0/40	1	oil sump
2	0.065.1550.0/10	1	gasket
3	2.3199.001.2	2	plug 1/2" gas
4	2.1560.054.0	2	gasket 21 x 26
5	2.0112.226.2	4	screw m 8 p.1.25 x 85
6	2.0112.215.2	17	screw m 8 p.1.25 x 40
7	2.1470.004.2	26	lock washer 8
8	0.065.1531.3/20	1	tube
9	2.0112.209.2	1	screw m 8 p 1.25 x 25
10	2.1011.105.2	1	nut m 8 p.1.25
11	2.1470.004.2	2	lock washer 8
12	0.065.1538.0	1	flange
13	2.1539.040.0	1	special oil seal 21.82 x 3.53
14	2.0312.216.2	2	screw m 8 p.1.25x50
15	2.1310.004.2	2	flat washer 8.4x17
16	0.065.1540.3/20	1	oil cooler
16	0.086.1540.3	1	oil cooler
17	2.1539.048.0	2	special oil seal 20.35x1.78
18	0.086.1513.2/30	1	dipstick
19	2.1539.065.0	2	special oil seal 8.73 x 1.78
20	2.1560.014.0	1	washer 18.2 x 24
21	0.052.1856.0	2	gasket
23	0.044.1567.0	1	oil filter element
23	2.4419.340.0	1	oil filter element
24	2.3339.307.0	1	pipe fitting m 22 p.1.5-3/4"
25	2.3339.353.2/20	1	pipe fitting 12 p.1.5-18 p.1.5
27	2.0399.113.2/10	2	screw
27	2.0399.125.2/10	2	screw m 8 x 55
28	2.1579.766.2	1	spacer 8.5x16x10
29	2.0112.239.2	2	screw m 8 p.1.25 x 150
30	2.0112.235.2	3	screw m 8 p.1.25 x 130

Section: ENGINE
LUBRICATION



642 - 10

Fig.	P/n	QTY	Name
Notes:			
[EXPLORER 90 Special -> 2500]			
1	0.066.1552.4/10	1	sediment bowl ☞ 01.00.30
2	2.1539.074.0	1	special oil seal 7.66 x 1.78
3	2.1539.072.0	2	special oil seal 23.52 x 1.78
4	0.066.1558.0	1	bush
5	2.0312.221.2	2	screw m 8 p.1.25x75
6	2.1480.014.1	2	washer 8
7	2.6859.073.2	1	clamp
8	0.066.1557.2	1	tube
9	0.066.1559.0	1	tube
10	0.075.1151.0	1	bracket
11	2.3350.003.1	1	nosepiece 8
12	2.3339.418.1	1	pipe fitting m 12 p.1
13	0.066.1556.0	1	tube
14	0.075.1552.2	1	bracket
15	0.075.1552.0	1	bracket
16	2.1011.103.2	1	nut m 6 p.1
17	2.1470.002.2	1	lock washer 6

Thank you so much for reading.
Please click the “Buy Now!”
button below to download the
complete manual.



After you pay.

You can download the most
perfect and complete manual in
the world immediately.

Our support email:

ebooklibonline@outlook.com