

Section: ENGINE
CRANKCASE

Fig.	P/n	QTY	Name
------	-----	-----	------

Notes:
 [EXPLORER II 70]

1	0.087.0050.6/10		gasket set - FOR ENGINE MOUNTING
2	0.066.1130.0/20	1	flange
3	2.0112.511.2	8	screw m 14 p.2 x 30
8	2.1099.108.2	4	special nut m 10 p.1
9	2.1560.006.0	8	gasket 10.2 x 16
10	0.086.1550.2	4	sprayer nozzle
11	0.065.1160.3/20	4	valve
12	2.1539.047.0	1	special oil seal 26.7x1.78
13	2.3199.405.2	1	plug m 28 p.1.5
16	2.0432.003.7	12	stud bolt m 8 p.1.25 / p.1 x 20
19	2.1519.096.0/20	4	special oil seal 107.67x1.78 26012 <= X 70HP - 80HP 6768 <= X 90HP
19	2.1539.130.0/10	4	special oil seal 117.07x3.53 => 26013 X 70HP - 80HP => 6769 X 90HP
20	0.007.0762.0/50	4	engine cylinder => 26013 X 70HP - 80HP => 6769 X 90HP
20	0.085.1120.0/10	4	engine cylinder 26012 <= X 70HP - 80HP 6768 <= X 90HP
25	0.066.1152.0/10	4	gasket
26	0.007.1140.6/10	1	crankcase => 26013 X 70HP - 80HP => 6769 X 90HP
26	0.086.1110.6	1	crankcase 26012 <= X 70HP - 80HP 6768 <= X 90HP
27	0.065.1112.7	1	support
28	2.1699.165.0	1	bush 12.3x15x16
29	0.065.1116.3	1	support
30	2.1699.165.0	1	bush 12.3x15x16
31	0.066.1151.0	1	pin
32	0.065.1141.0	1	special bushing 59X55X30
33	0.065.1140.0	4	special bushing 59X55X20
34	2.3179.012.0	1	plug 60
35	2.3130.001.1	11	plug 1/8" gas
36	2.3130.002.1	2	plug 1/4" gas
37	2.3130.003.1	7	plug 3/8" gas

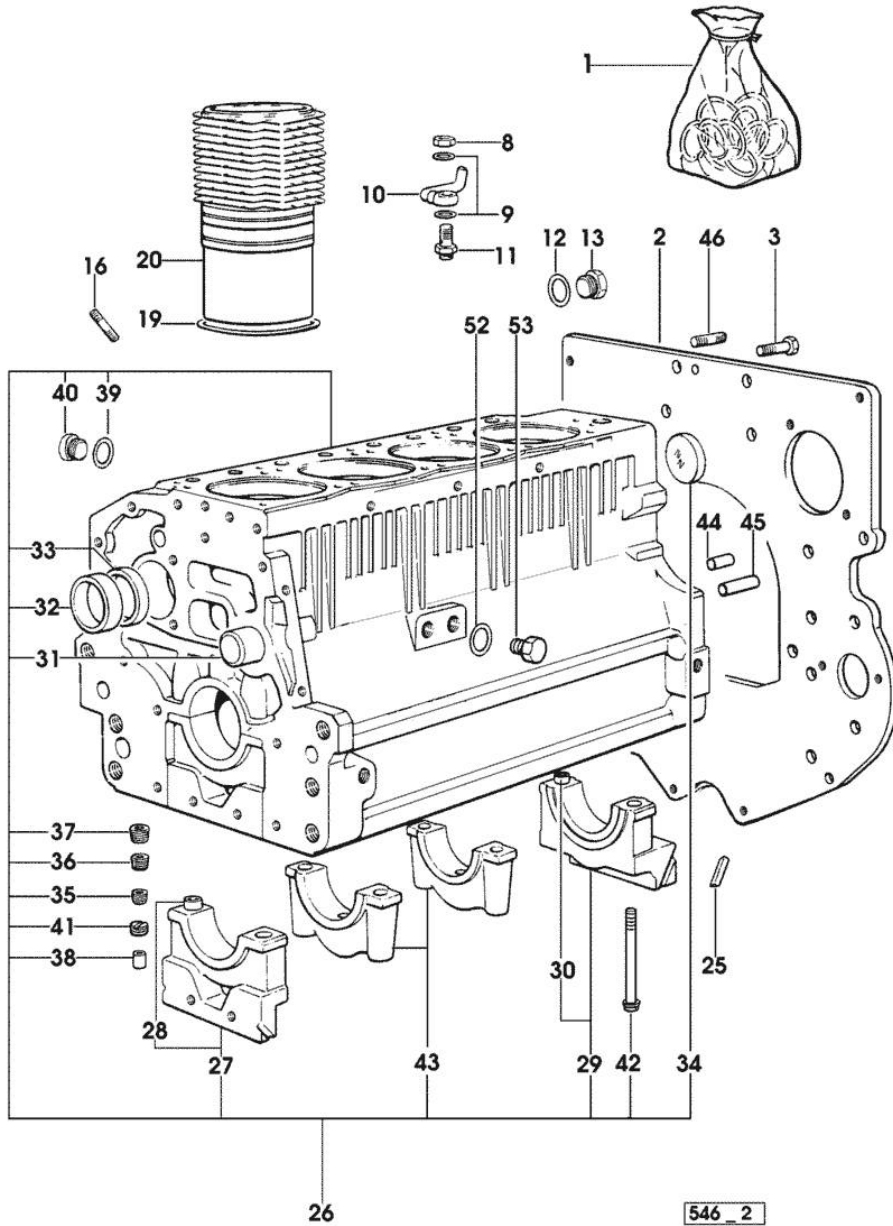

Section: ENGINE
CRANKCASE

Fig.	P/n	QTY	Name
38	2.3199.092.0	4	plug 8 x 12
39	2.1560.017.0	1	gasket 22.2 x 27 (...) <=
40	2.3120.002.4	1	plug m 22 x 1.5 (...) <=
41	2.1324.011.0	1	plug
42	0.065.1117.0	10	screw m 12 x 100
43	0.065.1114.0/10	3	support
44	2.1651.912.0	2	cylindrical plug 12x28
45	2.1651.917.0	1	cylindrical plug 12x40
46	2.0432.255.7	2	stud bolt m 12 p.1.75-1.25x25
52	2.1560.017.0	1	gasket 22.2 x 27
53	2.3120.002.4	1	plug m 22 x 1.5

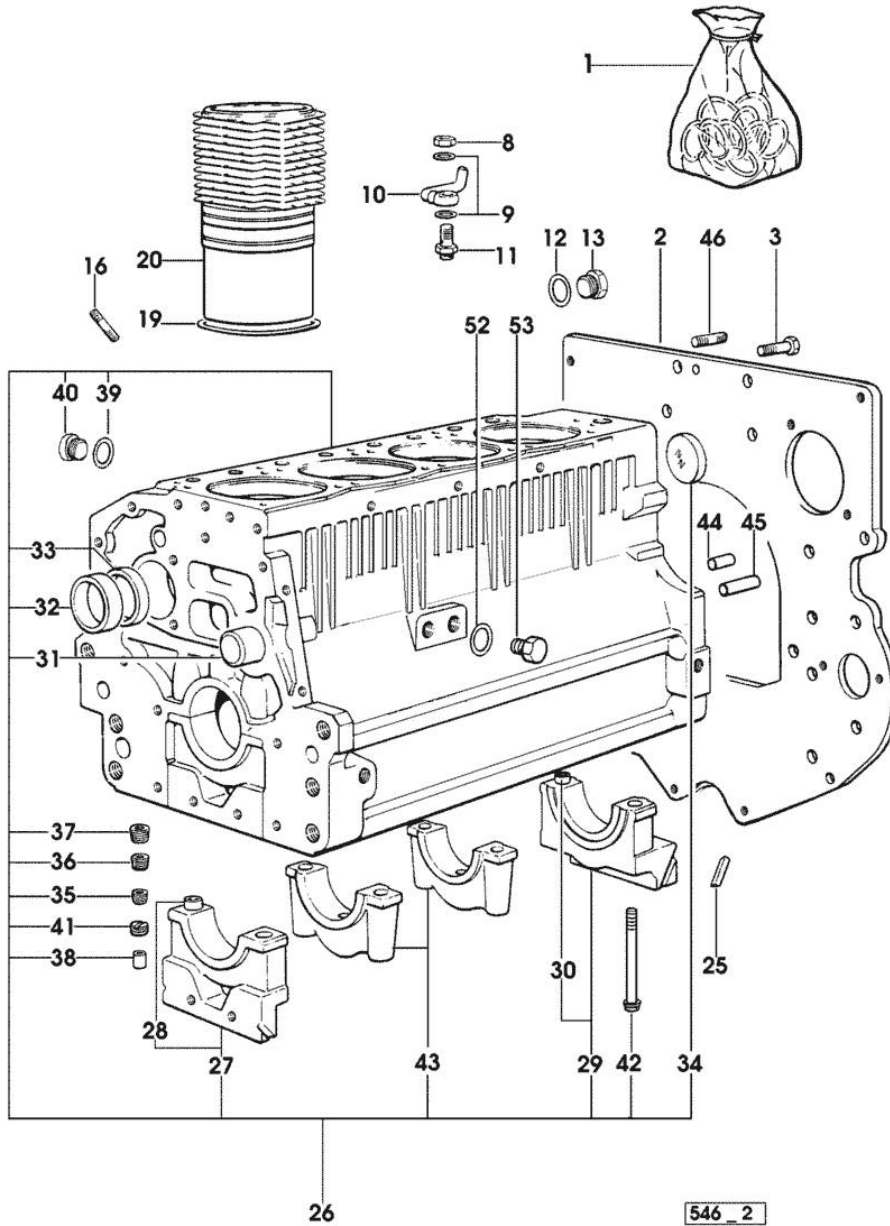

Section: ENGINE

TIMING CASE

Fig.	P/n	QTY	Name
------	-----	-----	------

Notes:

[EXPLORER II 70]

1	0.007.1262.3/50	1	guard
2	0.007.1271.0/10	1	small column m 8 p.1.25 / L = mm 60
3	0.007.1272.0/10	2	small column m 8 p.1.25 / L = mm 50
5	2.1310.004.2	3	flat washer 8.4x17
7	2.0112.205.2	3	screw m 8 p.1.25 x 16

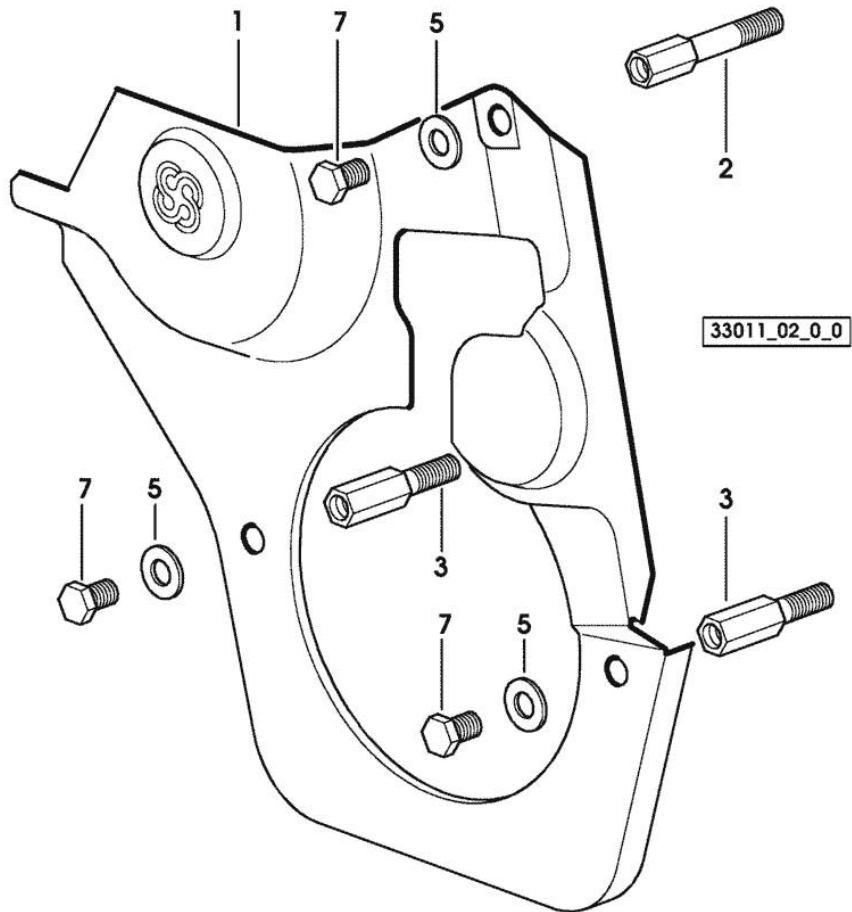

Section: ENGINE
TIMING CASE

Fig.	P/n	QTY	Name
------	-----	-----	------

Notes:
[EXPLORER II 70]

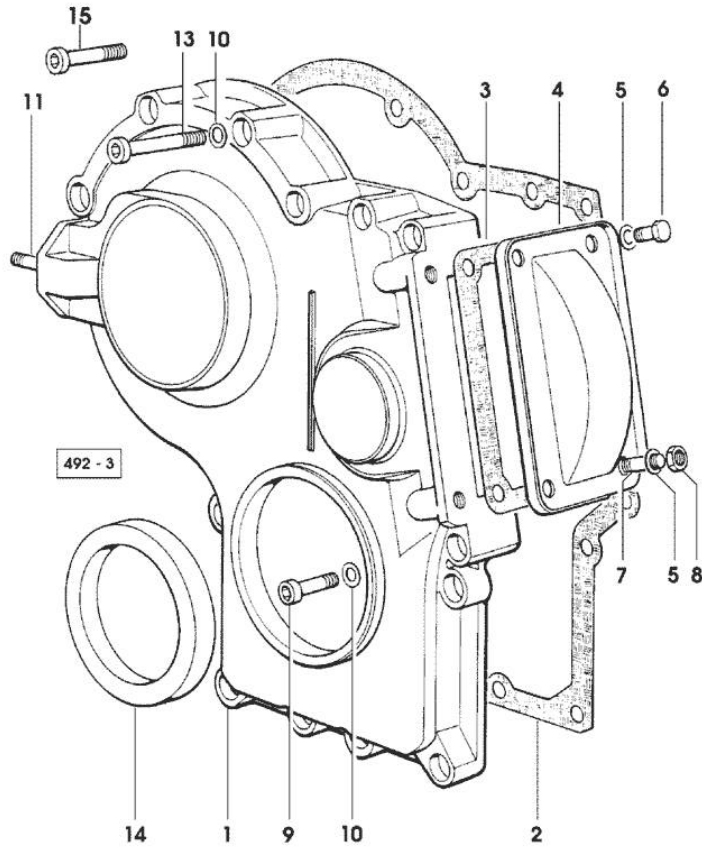

1	0.065.1132.0/60	1	guard
2	0.065.1150.0/30	1	gasket
3	0.065.1152.0	1	gasket
4	0.065.1151.0	1	cover
5	2.1470.004.2	4	lock washer 8
6	2.0112.205.2	2	screw m 8 p.1.25 x 16
7	2.0432.003.7	2	stud bolt m 8 p.1.25 / p.1 x 20
8	2.1011.405.2	2	nut m 8 p.1
9	2.0312.208.2	8	screw m 8 p.1.25 x 25
10	2.1480.014.1	15	washer 8
11	2.0432.003.7	2	stud bolt m 8 p.1.25 / p.1 x 20
13	2.0312.214.2	3	screw m 8 p.1.25 x 40
14	2.1529.141.0	1	special oil seal
15	2.0312.219.2	4	screw m 8 p.1.25x65

Section: ENGINE

CRANKSHAFT

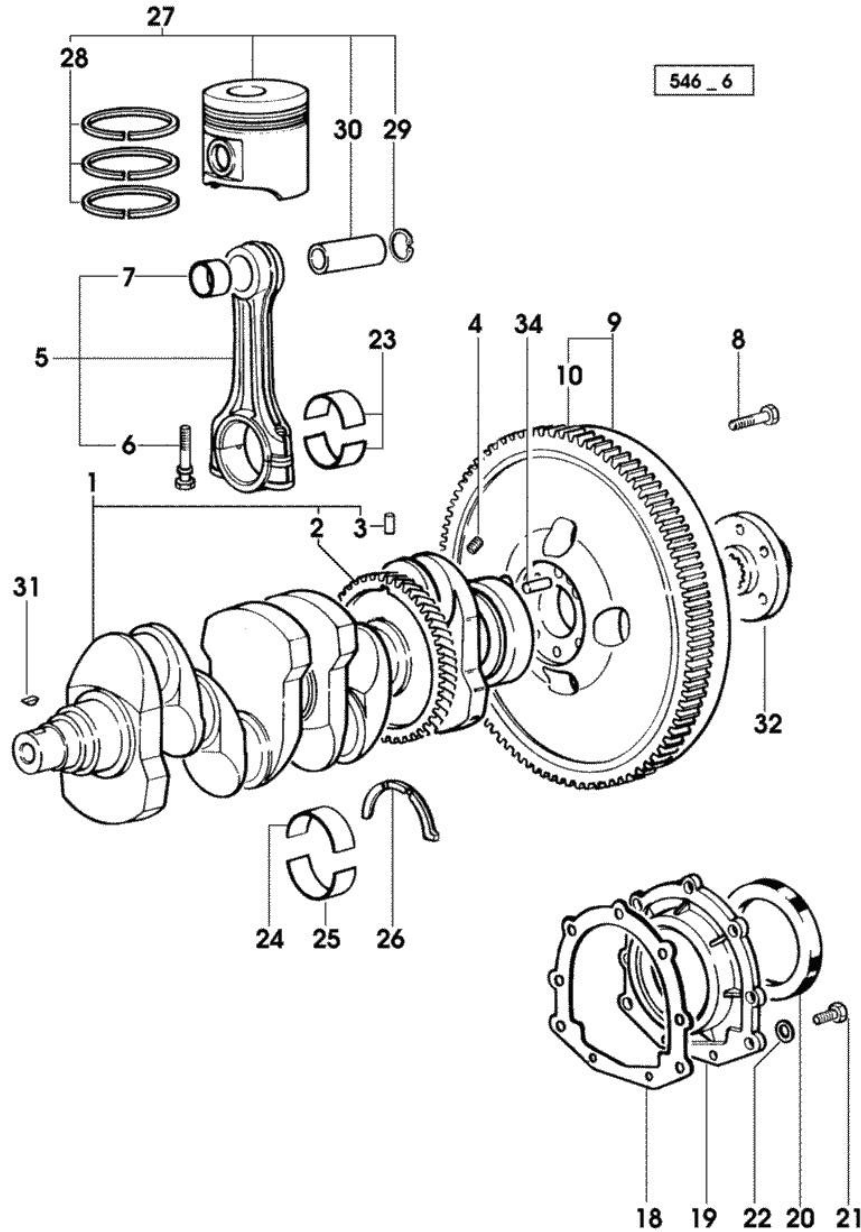

Fig.	P/n	QTY	Name
Notes:			
[EXPLORER II 70]			
1	0.086.1210.3/30	1	crankshaft * 31067 <= - N.1 - 007.1711.0/10 - N.4 - 2.3130.001.1
2	0.065.1211.0/10	1	crown wheel
3	2.1630.608.0	1	pin 6x16
4	2.3130.001.1	4	plug 1/8" gas
5	0.078.1220.3/30	4	engine connecting rod
6	2.0399.213.0	8	screw m 12 p.1.25x61.5
7	2.1559.114.0/10	4	special bushing
8	2.0139.022.2	6	screw m 12 p.1.25x55
9	0.065.1247.3/30	1	flywheel 22091 <= => 22092
9	0.076.1247.3/20	1	flywheel => 22092
10	0.065.1242.0	1	crown wheel Z = 123
18	0.065.1254.0/20	1	gasket
19	0.007.1711.0/10	1	cover => 31068
19	0.065.1253.0/20	1	cover 31067 <= special oil seal 110x130x13
20	2.1529.073.0	1	special oil seal 110x130x13
21	2.0112.207.2	9	screw m 8 p 1.25 x 20
22	2.1475.002.2	9	conical washer 8
23	0.065.1225.0	8	con.rod half bushing STANDARD - A = 28.75 -> 29.00
23	0.065.1225.7		con.rod half bushing - mm 0.25
23	0.065.1225.8		con.rod half bushing - mm 0.50
24	0.065.1215.0	5	main half bushing STANDARD
24	0.065.1215.7		main half bushing - mm 0.25
24	0.065.1215.8		main half bushing - mm 0.50
25	0.065.1216.0	5	main half bushing
25	0.065.1216.7		main half bushing - mm 0.25
25	0.065.1216.8		main half bushing - mm 0.50
26	0.065.1218.0	4	shim STANDARD
26	0.065.1218.7		shim + mm 0.10
26	0.065.1218.8		shim + mm 0.15
27	0.086.0060.6/30	4	complete piston
27	0.379.0060.6	4	complete piston - EXPORT U.S.A.
28	0.086.0052.6/10	4	piston ring set
29	2.1411.014.1	8	circlip 35
30	0.078.1236.0	4	piston pin Ø 18 / Ø 35 / L = mm 86

CRANKSHAFT

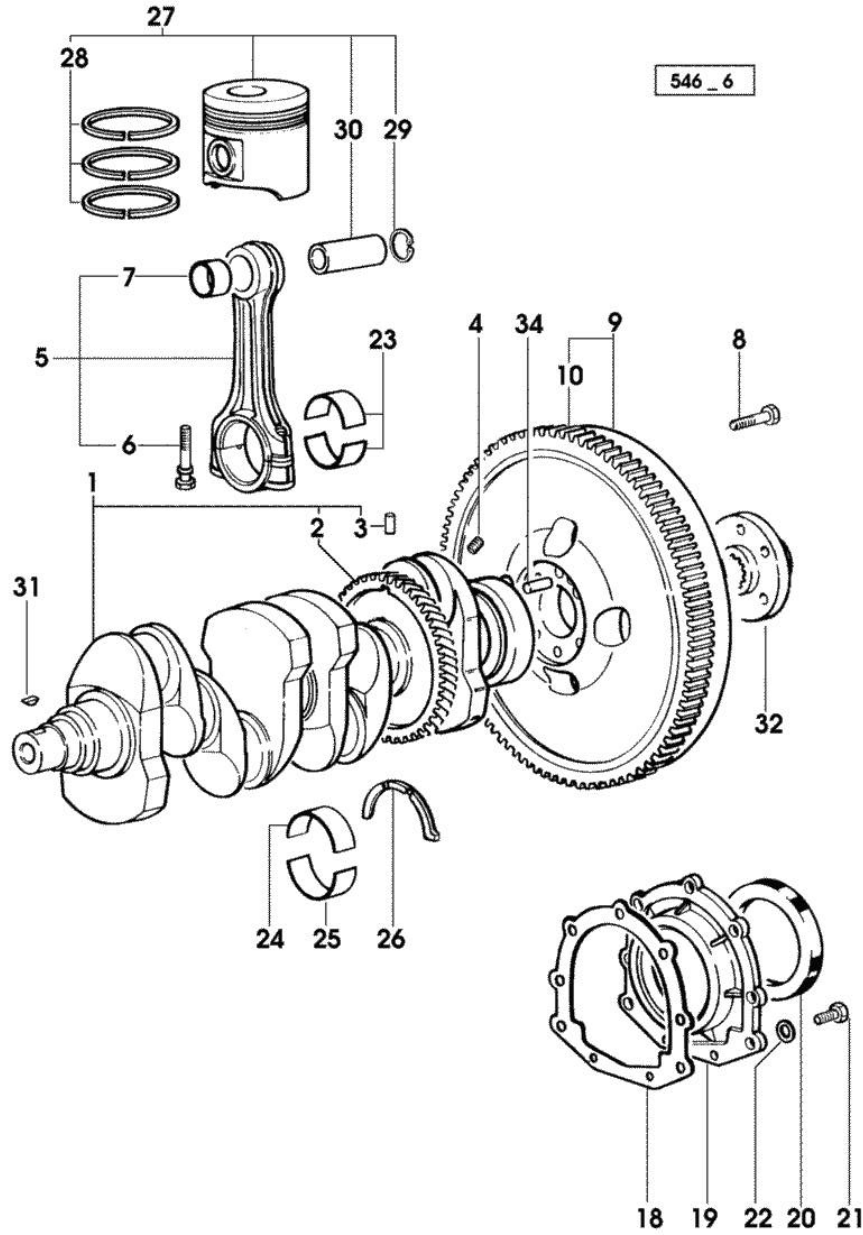

Fig.	P/n	QTY	Name
31	2.1720.006.0	3	key 4x6.5
32	0.255.2525.0/10	1	flange
34	2.1652.915.0	1	cylindrical plug 12x35

Section: ENGINE

ENGINE SHAFT - PULLEYS

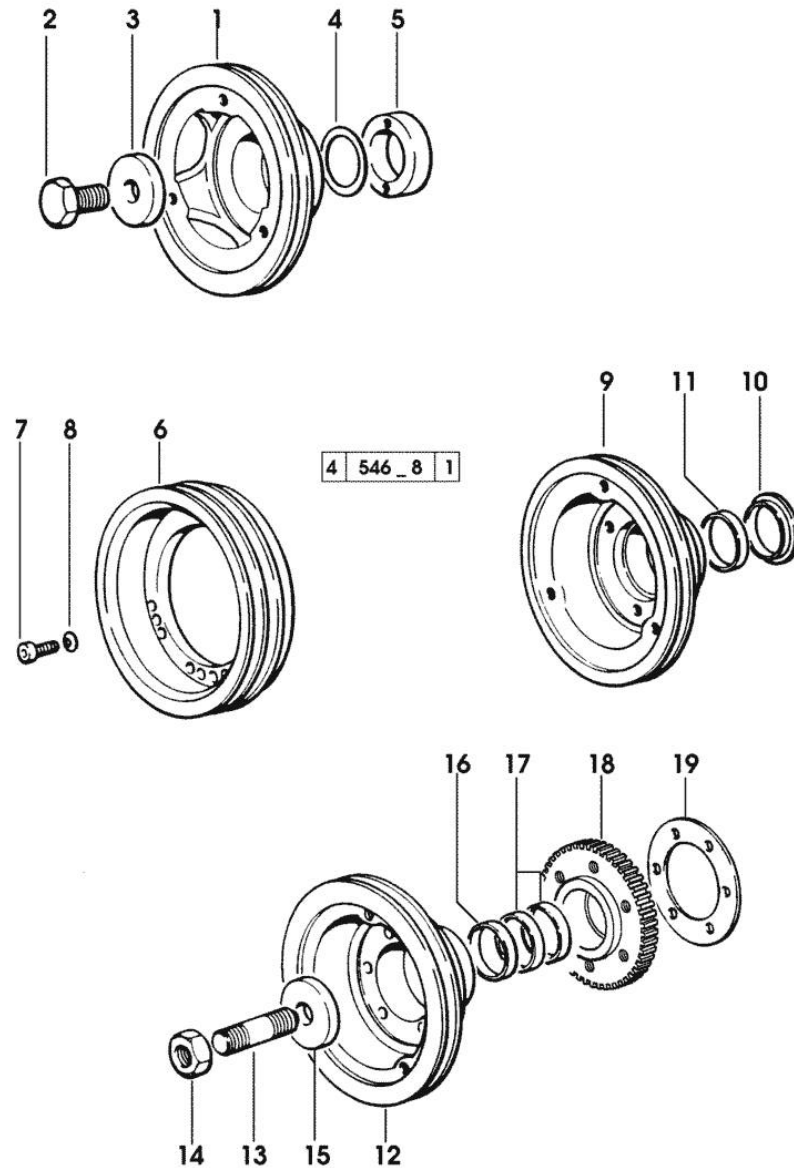

Fig.	P/n	QTY	Name
------	-----	-----	------

Notes:
[EXPLORER II 70]

1	0.007.1330.0/30	1	pulley
2	2.0399.144.7/10	1	screw m 20 p.1.5x51 * (...) <=
			- N.1 - 2.1599.524.7
3	2.1599.524.7	1	washer 21x60x12 * (...) <=
			- N.1 - 2.0399.144.7
4	2.1589.189.0	3	shoulder ring mm 1.00
5	0.085.1248.0/10	1	hub
6	0.086.1251.0	1	pulley - FOR ACCESSORIES
7	2.0312.308.1	3	screw m 10 p.1.5 x 25
8	2.1480.015.1	3	washer 10
9	0.085.1253.0/10	1	pulley (...) <=
			- FOR P.T.O. FRONT
10	0.085.1254.0	1	ring
11	0.065.1256.0	1	ring 45x52
12	0.086.1244.0	1	pulley => (...)
			- FOR P.T.O. FRONT
13	2.0439.195.7	1	stud bolt m 20 p.1.5x80
14	2.1019.094.7	1	nut m 20 p.1.5
15	2.1599.524.7	1	washer 21x60x12
16	2.1579.865.0	1	spacer 45.2x51.8x10
17	0.065.1256.0	2	ring 45x52
18	0.011.3515.0/10	1	hub Z = 48
19	2.1589.136.0	3	shoulder ring 71x110x0.5
19	2.1589.137.0	1	shoulder ring 71x110x1

Section: ENGINE

COUNTERWEIGHTS

Fig.	P/n	QTY	Name
------	-----	-----	------

Notes:
[EXPLORER II 70]

1	0.086.1233.3/30	1	mass sx/lh/li
2	2.1559.115.0	2	special bushing 26x30x30
3	2.1652.302.0	1	roll pin 4x6
4	0.000.0000.1		cannot be supplied
5	0.065.1233.3/30	1	mass dx/rh/re
6	2.1410.018.7	1	circlip 45
7	2.1652.302.0	1	roll pin 4x6
8	2.1559.115.0	2	special bushing 26x30x30
9	0.000.0000.1		cannot be supplied
10	2.1589.185.0	4	shoulder ring 26.1x34x1
11	2.1631.717.0	2	roll pin 8 x 40
12	0.086.1231.0/10	1	box
13	2.3130.001.1	4	plug 1/8" gas
14	2.0139.028.2	4	screw m 12
15	2.1579.628.0	2	spacer 16.5x26x0.1
15	2.1589.048.0	2	shoulder ring 16.5x26x0.3
16	2.1579.629.0		spacer 12.5x26x0.1
16	2.1589.049.0		shoulder ring 12.5x26x0.3
17	2.1579.626.0	2	spacer 13.2x16x11
18	2.1589.139.0	2	shoulder ring mm 0.3
19	2.1589.140.0	2	shoulder ring mm 0.1
20	2.1699.191.0	1	bush 7x10x16
21	0.065.1234.0/10	2	shaft
22	2.3130.001.1	2	plug 1/8" gas

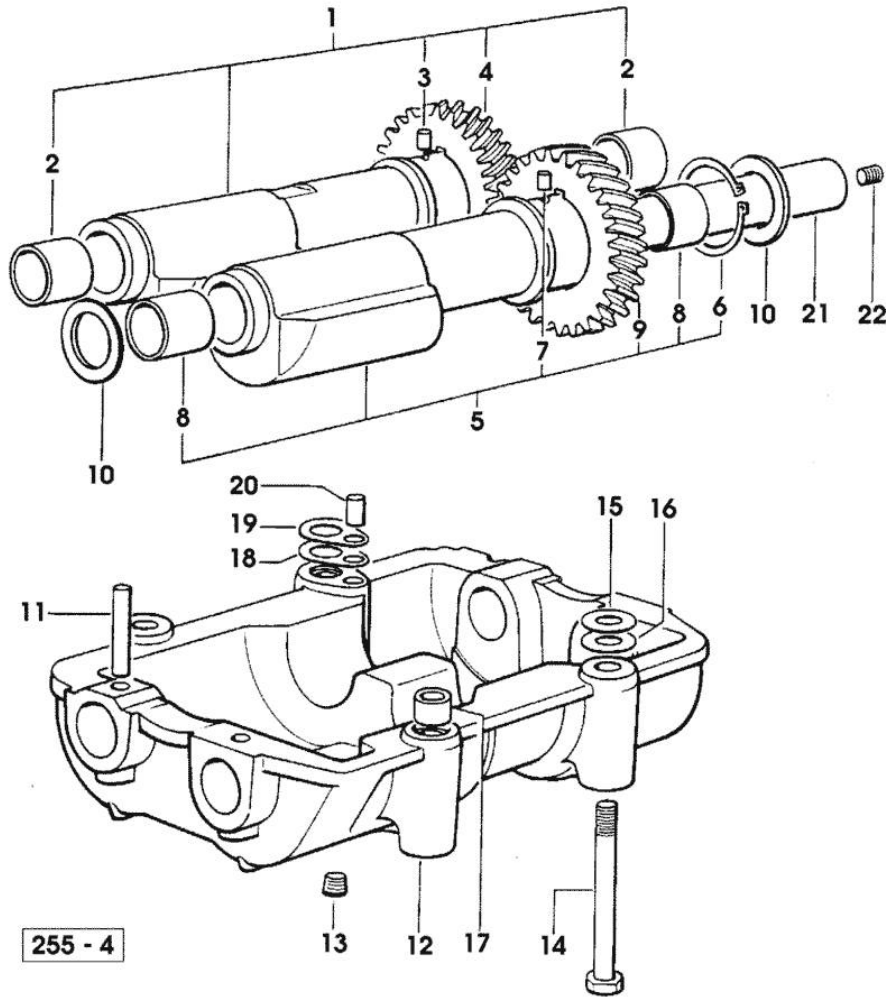

Section: ENGINE

CAMSHAFT

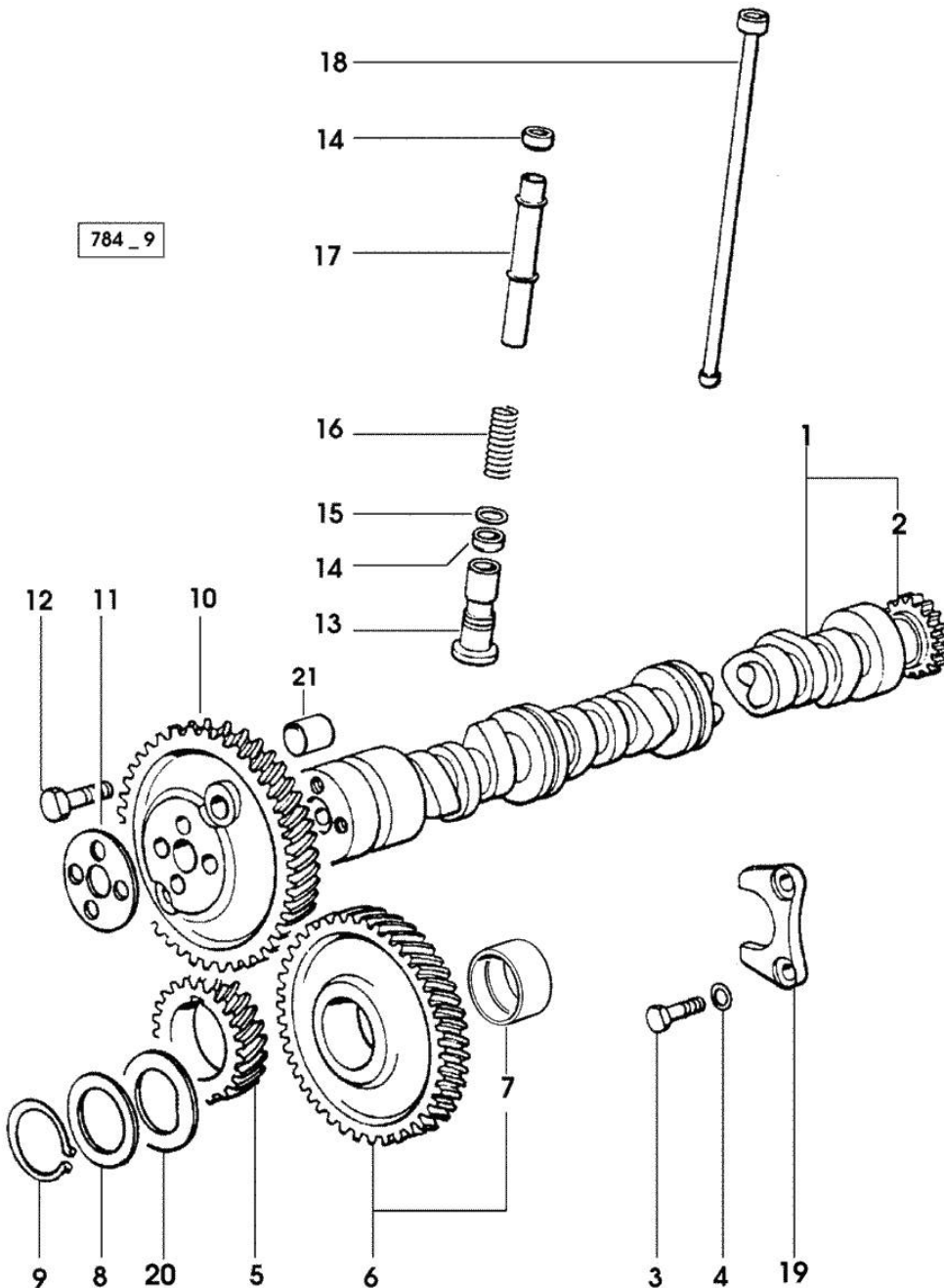

Fig.	P/n	QTY	Name
------	-----	-----	------

Notes:
[EXPLORER II 70]

1	0.007.1712.3/10	1	camshaft - EXPORT U.S.A.
1	0.066.1310.3/40	1	camshaft
2	0.065.1324.0/10	1	gear Z = 32
3	2.0312.206.2	2	screw m 8 p 1.25 x 20
4	2.1480.014.1	2	washer 8
5	0.065.1323.0/30	1	gear Z = 29
6	0.007.1177.3/10		gear z = 57 - WITH RED IDENTIFICATION STAMP
6	0.007.1178.3/10		gear z = 57 - WITH YELLOW IDENTIFICATION STAMP
6	0.007.1179.3/10		gear z = 57 - WITH GREEN IDENTIFICATION STAMP
7	2.1559.185.0/10	1	bushing
8	0.065.1352.0	1	shim
9	2.1410.016.1	1	circlip 40
10	0.065.1354.0/20	1	gear z=58
11	0.065.1350.0	1	small disc
12	2.0132.207.2	4	screw m 10 p.1 x 25
13	0.065.1330.0	8	tappets
14	2.1569.114.0/10	16	gasket 14x18.5x8
15	2.1599.437.0	8	shoulder ring
16	2.4019.300.1/10	8	spring 18.5x52x2
17	0.065.1332.0	8	sleeve
18	0.065.1331.2	8	rod
19	0.065.1353.0	1	small plate
20	0.065.1351.0	2	shoulder ring
21	2.1559.398.0	1	bushing 10.5x13x12

Section: ENGINE
CYLINDER HEAD

Fig.	P/n	QTY	Name
------	-----	-----	------

Notes:
[EXPLORER II 70]

1	2.0399.130.2	4	screw m 8 x 30 39125 <= X 70HP - 80HP 11244 <= X 90HP
1	2.0399.130.2/10	4	screw m 8x36x44 => 39126 X 70HP - 80HP => 11245 X 90HP
2	2.1569.170.0/10	4	gasket 8.2 x 14
3	0.007.1139.0/10	4	small cap * 39125 <= X 70HP - 80HP * 11244 <= X 90HP - N.1 - 2.0399.130.2/10
4	0.065.1450.0/30	1	tappet gasket
5	2.1011.321.2	8	nut m 10 p.1.25
6	2.0432.163.7	8	stud bolt m 10 p.1.5 / p.1.25 x 45
7	0.066.1430.0/10	4	support
8	0.066.1432.3	8	rocker arm
9	2.1559.021.0/40	8	bushing 15x19x22
10	2.1410.055.1	8	circlip 19
11	2.1011.405.2	8	nut m 8 p.1
12	0.021.1434.0	8	screw
13	0.074.1423.0	8	conical valve cotter
14	0.066.1425.0	8	cup
15	2.4019.287.0	8	spring
16	0.065.1413.0/10	4	bush L = mm 97.1 27322 <= X 70HP - 80HP 7149 <= X 90HP
17	2.0432.161.7	4	stud bolt m 10 p.1.5 / p.1.25 x 40
18	0.065.1443.0/20	16	screw
20	2.0432.007.2	8	stud bolt m 8 p.1.25 / p.1 x 30
21	0.085.1450.0		head gasket mm 0.5 -A-
21	0.085.1451.0		head gasket mm 0.7 -B-
21	0.085.1452.0		head gasket mm 1.0 -C-
21	0.085.1453.0		head gasket mm 0.8 -D-
22	0.010.6022.0	4	exhaust valve mm 39.1 / Ø mm 9 - X 90HP -> (...) = B
22	0.066.1421.0	4	exhaust valve - X 70HP - 80HP - X 90HP (...) <= A
23	0.010.6016.0	4	inlet valve mm 43.63 / Ø mm 9 - X 70HP - 80HP
23	0.010.6017.0	4	inlet valve mm 43.63 / Ø mm 9

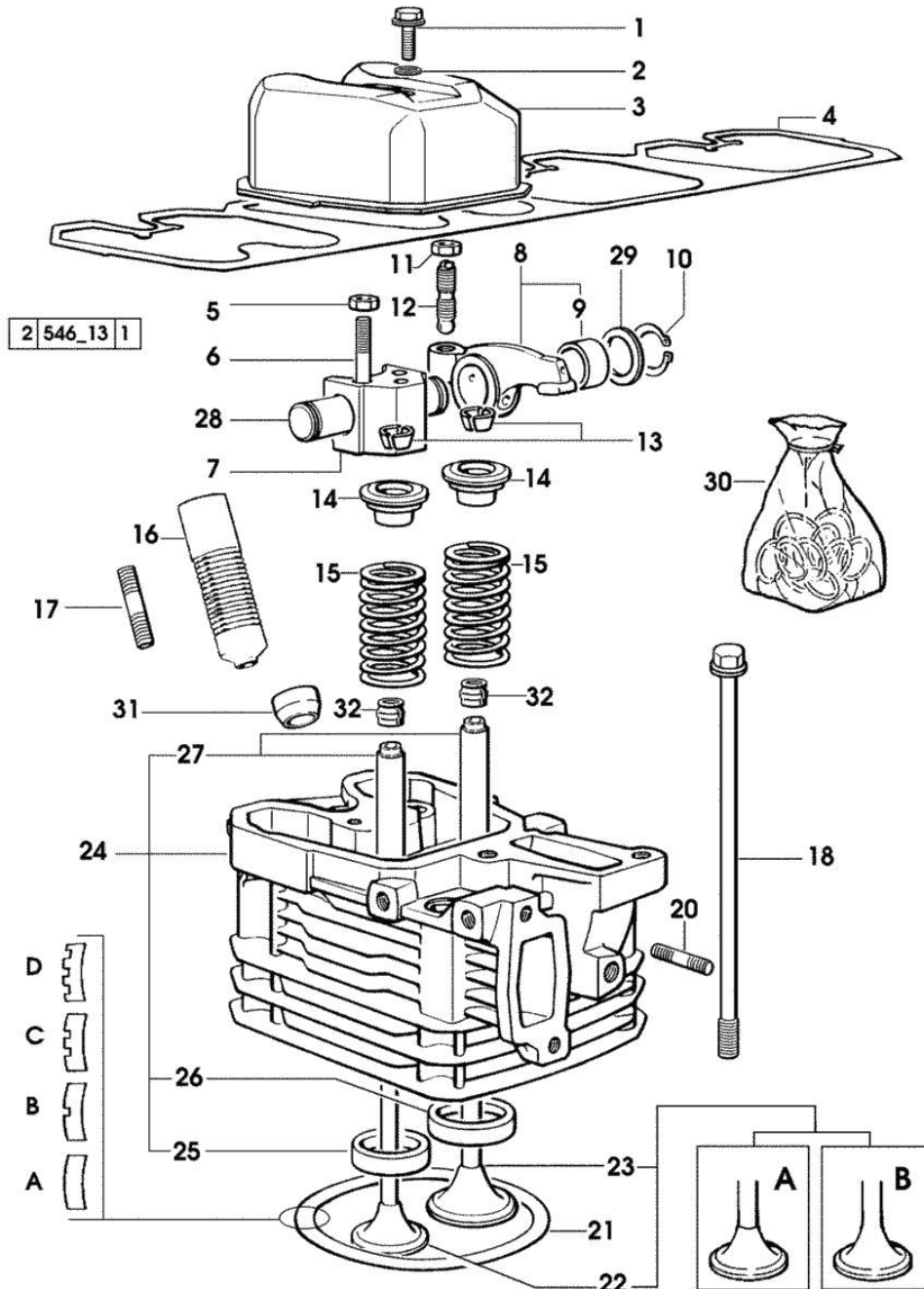

Section: ENGINE
CYLINDER HEAD

Fig.	P/n	QTY	Name
23	0.081.1420.0	4	- X 90HP -> (...) = B inlet valve Ø mm 9
24	0.007.1110.3/50	4	- X 90HP (...) <- = A engine head * 27322 <= X 70HP - X 80HP * 7148 <= X 90HP - N.1 - 007.1122.0/10 - X 90HP (...) <- = A
24	0.007.1359.3/50	4	engine head - X 90HP -> (...) = B
25	0.066.1427.0	4	valve seat
26	0.078.1426.0	4	valve seat
27	0.007.1779.0/10	8	valve guide
28	0.066.1431.0	4	pin
29	2.1599.432.0	8	shoulder ring
30	0.085.0057.6/10		gasket set - FOR 1 CYLINDER VALVE GRINDING AND PISTON RINGS REPLACEMENT
31	0.007.1122.0/10	4	bush L = mm 6.4 => 27323 X 70HP - 80HP => 7149 X 90HP
32	2.1519.117.0	8	special oil seal

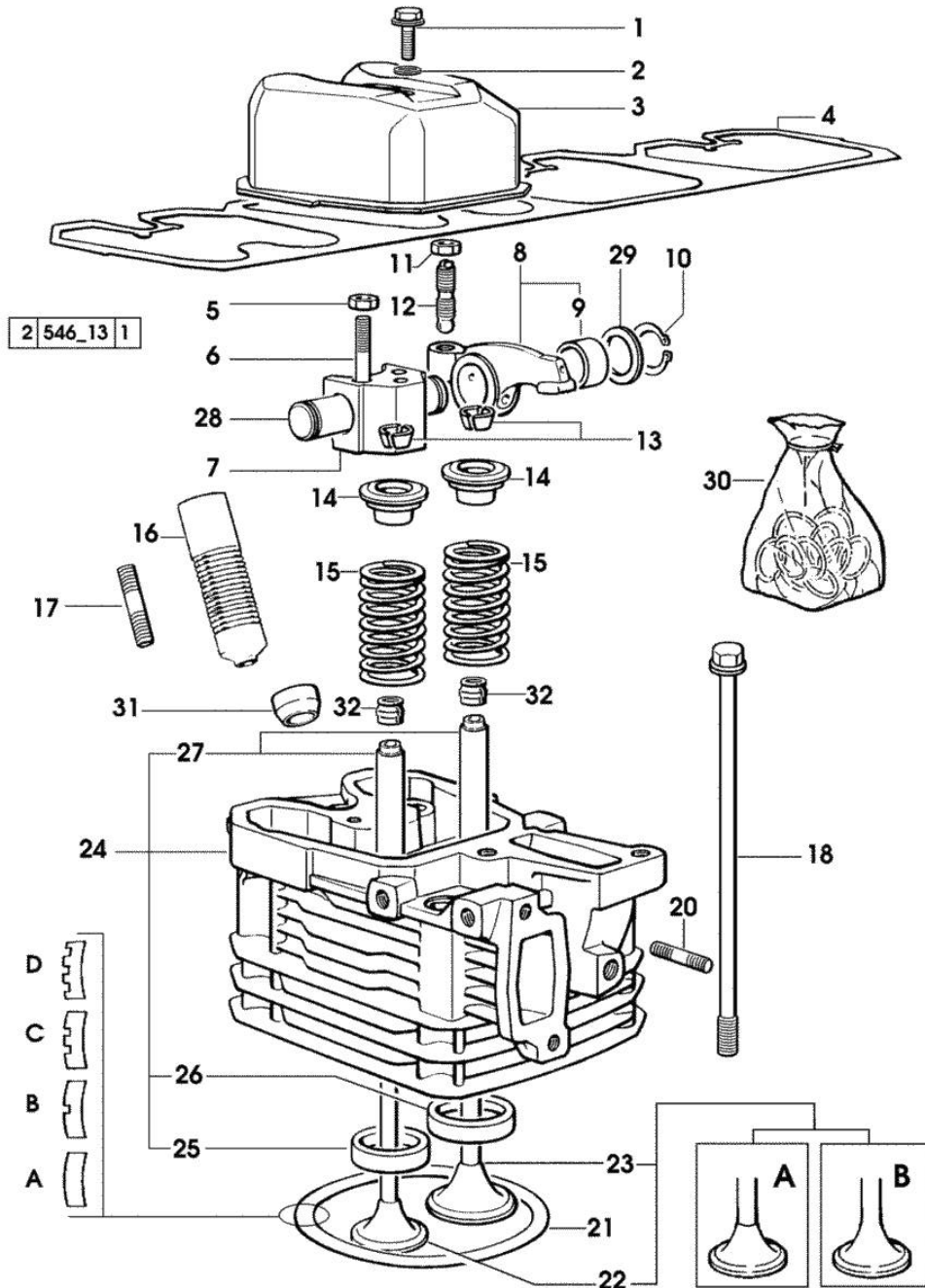

Section: ENGINE
LUBRICATION

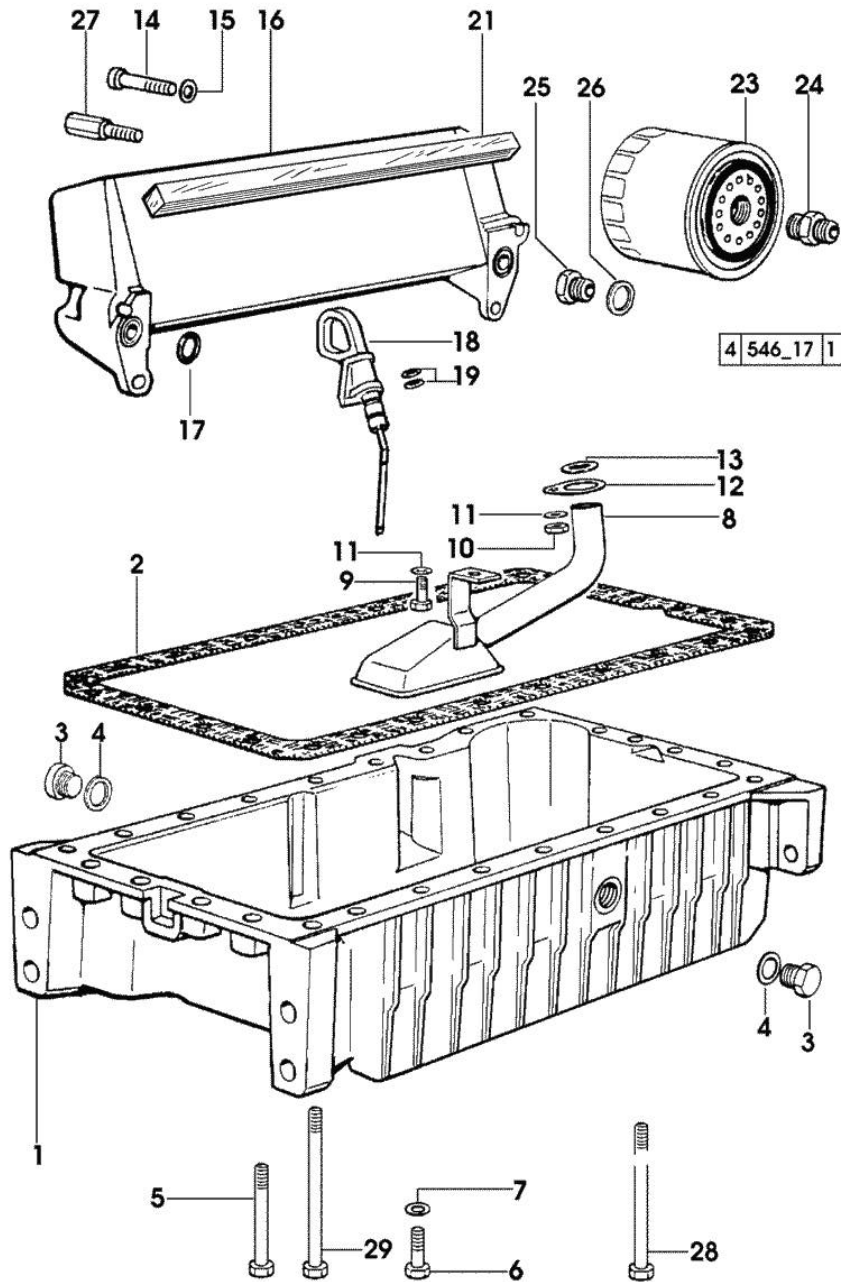

Fig.	P/n	QTY	Name
------	-----	-----	------

Notes:
[EXPLORER II 70]

1	0.007.1277.0/40	1	oil sump
2	0.065.1550.0/10	1	gasket
3	2.3199.001.2	2	plug 1/2" gas
4	2.1560.054.0	2	gasket 21 x 26
5	2.0112.226.2	4	screw m 8 p.1.25 x 85
6	2.0112.215.2	17	screw m 8 p.1.25 x 40
7	2.1470.004.2	26	lock washer 8
8	0.065.1531.3/20	1	tube
9	2.0112.205.2	1	screw m 8 p.1.25 x 16
10	2.1011.105.2	1	nut m 8 p.1.25
11	2.1470.004.2	2	lock washer 8
12	0.065.1538.0	1	flange
13	2.1539.040.0	1	special oil seal 21.82 x 3.53
14	2.0312.216.2	2	screw m 8 p.1.25x50
15	2.1310.004.2	2	flat washer 8.4x17
16	0.007.7320.3	1	oil cooler
16	0.065.1540.3/20	1	oil cooler
17	2.1539.048.0	2	special oil seal 20.35x1.78
18	0.086.1513.2/30	1	dipstick
19	2.1539.065.0	2	special oil seal 8.73 x 1.78
21	0.052.1856.0	2	gasket
23	0.044.1567.0	1	oil filter element
23	2.4419.340.0	1	oil filter element
24	2.3339.307.0	1	pipe fitting m 22 p.1.5-3/4"
25	2.3339.353.2/20	1	pipe fitting 12 p.1.5-18 p.1.5
26	2.1560.014.0	1	washer 18.2 x 24
27	2.0399.113.2/10	2	screw
27	2.0399.125.2/10	2	screw m 8 x 55
28	2.0112.235.2	3	screw m 8 p.1.25 x 130
29	2.0112.239.2	2	screw m 8 p.1.25 x 150

Section: ENGINE
LUBRICATION

Fig.	P/n	QTY	Name
------	-----	-----	------

Notes:
[EXPLORER II 70]

1	2.0312.206.2	2	screw m 8 p 1.25 x 20
2	2.1480.014.1	2	washer 8
3	0.041.1135.4	1	plug 1" gas
4	2.1569.072.0	1	gasket 32 x 39.5 x 2
5	0.065.1565.0/10	1	pipe union
6	0.010.5441.4/10	1	oil pump - X 70HP - 80HP - 90HP
6	0.010.5481.4	1	oil pump - X 60HP
7	0.065.1552.3/60	1	valve
8	2.1539.042.0	1	special oil seal 47.35x1.78
9	2.1651.711.0	2	pin 8 x 14
10	2.0169.005.2	2	screw m 6 p.1 x 12
11	0.065.1569.0/40	1	shaft
12	2.1470.006.2	2	lock washer 10
13	2.0112.325.2	2	screw m 10 p.1.5 x 80
14	0.065.1560.0/20	2	gasket
15	0.065.1562.0/10	1	joint
16	0.075.1551.4/20	1	support
17	2.2020.001.0	1	ball bearing 15 x 32 x 8.00
18	2.2725.016.0	1	roller cage 15 x 21 x 12
19	2.2680.020.0	1	ring 12 x 15 x 12
20	2.0399.128.2	1	screw (...) <=
20	2.0399.128.2/10	1	screw m 8 p.1 x 8 => (...)
21	2.2030.002.0	1	ball bearing 12 x 28 x 8
22	2.1219.025.2	1	ring nut m 36 p.1 (...) <=
22	2.1219.025.2/10	1	ring nut m 36 p.1.5 => (...)
23	2.1589.148.0	1	shoulder ring 28.2 x 31.8 x 0.5
23	2.1589.150.0		shoulder ring 28.2 x 31.8 x 0.1
23	2.1589.151.0		shoulder ring 28.2 x 31.8 x 0.15
24	0.075.1551.3/30	1	support * (...) <=
			- N.1 - 2.1519.025.2/10 - 2.0399.128.2/10
25	2.1589.146.0		shoulder ring 15.2 x 19 x 0.15
25	2.1589.147.0		shoulder ring 15.2 x 19 x 0.10
25	2.1589.153.0	1	shoulder ring 15.2 x 19 x 1.00
26	2.1410.057.1	1	circlip 15

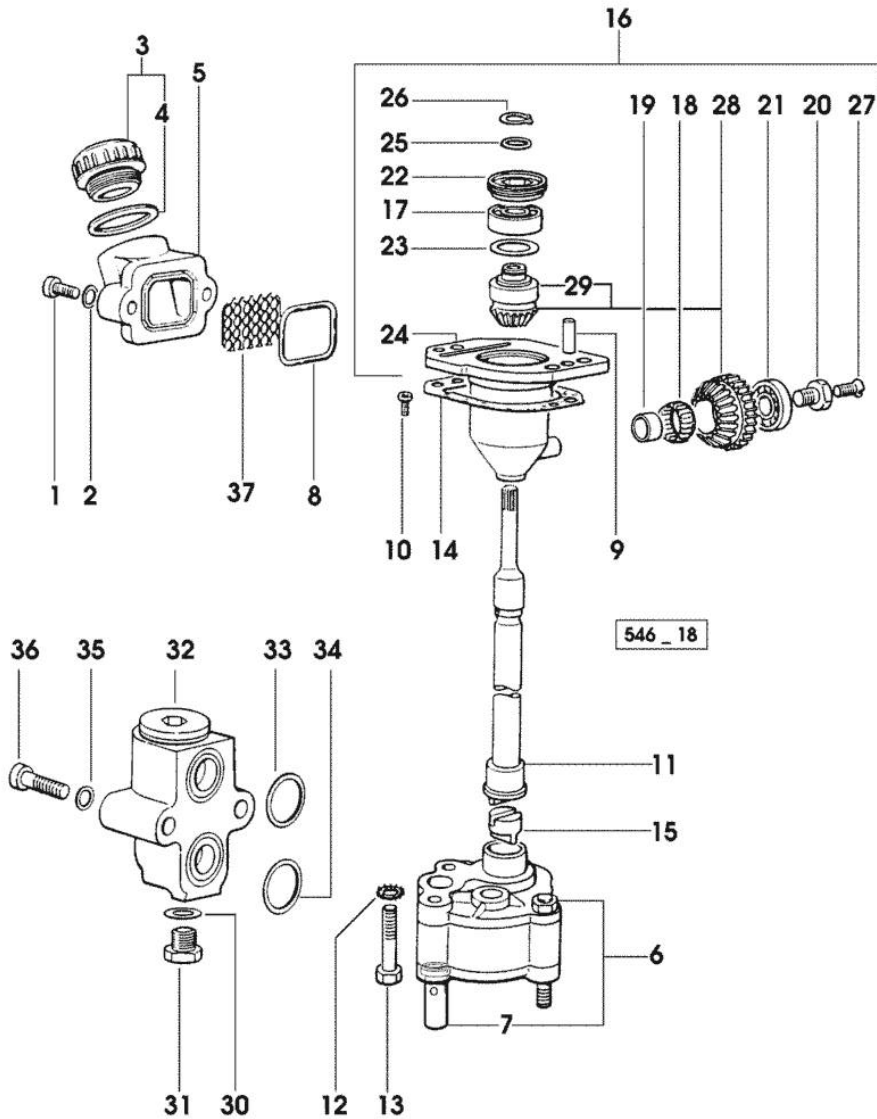

Section: ENGINE
LUBRICATION

Fig.	P/n	QTY	Name
27	2.0342.007.2	1	screw m 4 p.0.7x25
28	0.065.1558.6/10	1	bevel drive
29	0.065.1559.0	1	bush
30	2.1560.010.0	1	gasket 14.2 x 20
31	2.3110.403.1	1	plug m 14 p.1.5x12
32	0.065.1581.4/20	1	valve
33	2.1539.048.0	1	special oil seal 20.35x1.78
34	2.1539.072.0	1	special oil seal 23.52 x 1.78
35	2.1480.014.1	2	washer 8
36	2.0312.215.1	2	screw m 8 p.1.25 x 45
37	0.065.1567.0/10	1	filter

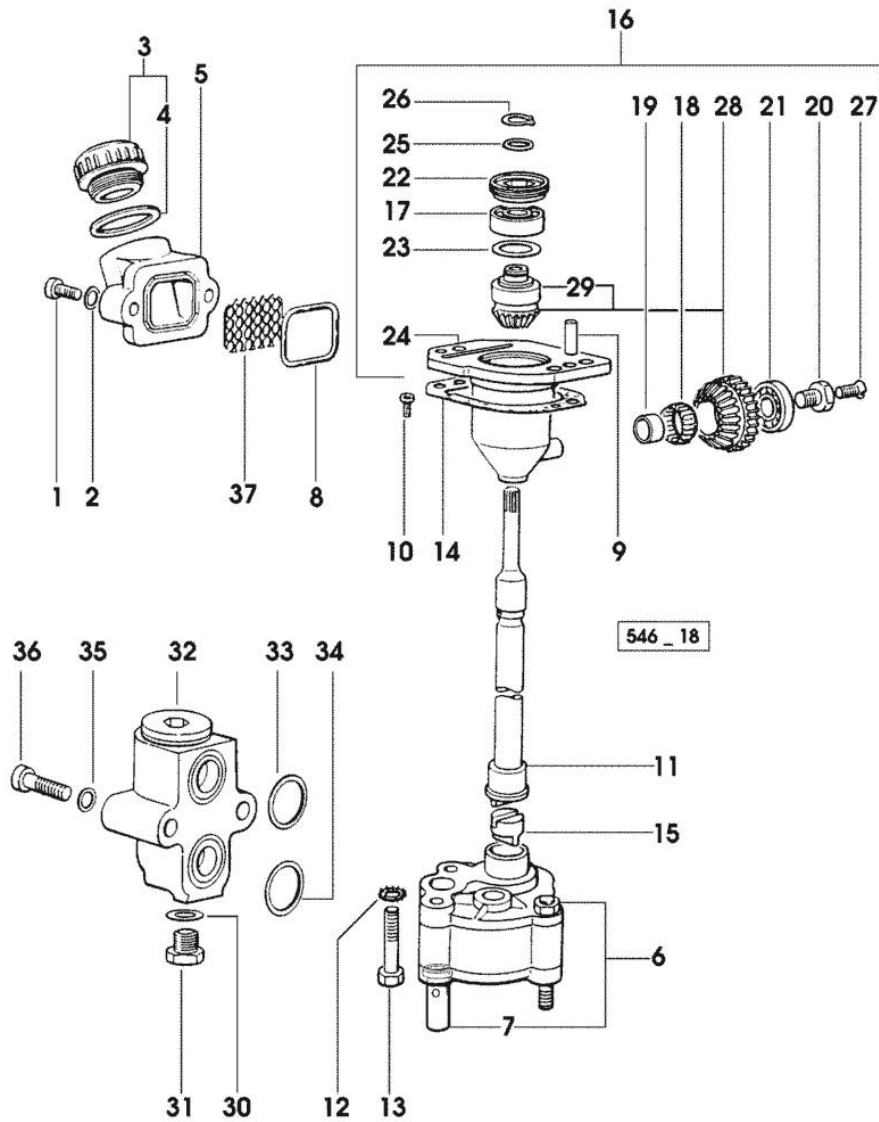

Section: ENGINE
LUBRICATION

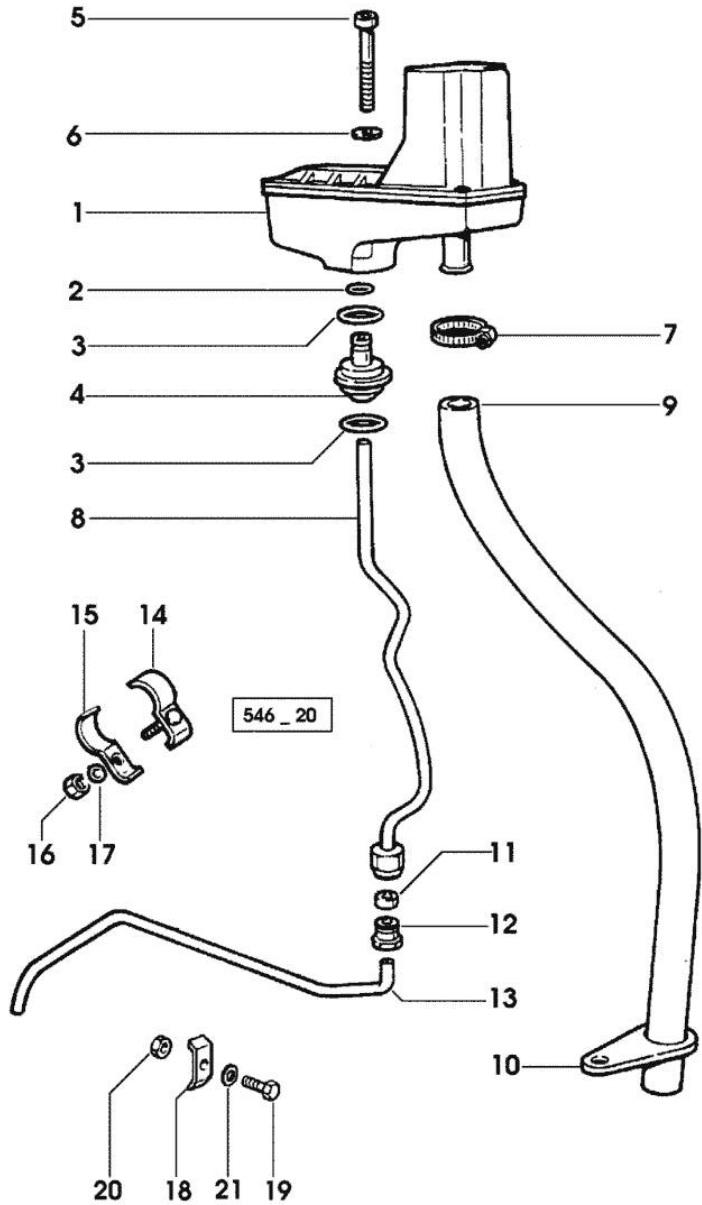

Fig.	P/n	QTY	Name
Notes: [EXPLORER II 70]			
1	0.066.1552.4/10	1	sediment bowl ☞ 01.00.65
2	2.1539.074.0	1	special oil seal 7.66 x 1.78
3	2.1539.072.0	2	special oil seal 23.52 x 1.78
4	0.066.1558.0	1	bush
5	2.0312.221.2	2	screw m 8 p.1.25x75
6	2.1480.014.1	2	washer 8
7	2.6859.073.2	1	clamp
8	0.066.1557.2	1	tube
9	0.066.1559.0	1	tube
10	0.075.1151.0	1	bracket
11	2.3350.003.1	1	nosepiece 8
12	2.3339.418.1	1	pipe fitting m 12 p.1
13	0.007.1427.0	1	tube => 13383 X 60HP
13	0.066.1556.0	1	tube - X 70HP - 80HP - 90HP
13	0.069.1550.0	1	tube 13382 <= X 60HP
14	0.075.1552.2	2	bracket - X 70HP - 80HP - 90HP 13382 <= X 60HP
15	0.075.1552.0	2	bracket - X 70HP - 80HP - 90HP 13382 <= X 60HP
16	2.1011.103.2	2	nut m 6 p.1
17	2.1470.002.2	2	lock washer 6
18	0.002.8816.0	1	small plate => 13383 X 60HP
19	2.0112.007.2	1	screw m 6 p.1 x 20
20	2.1011.103.2	1	nut m 6 p.1
21	2.1470.002.2	1	lock washer 6

Thank you so much for reading.
Please click the “Buy Now!”
button below to download the
complete manual.



After you pay.

You can download the most
perfect and complete manual in
the world immediately.

Our support email:

ebooklibonline@outlook.com