

Section: ENGINE
CRANKCASE

9_M8211_00_0_A

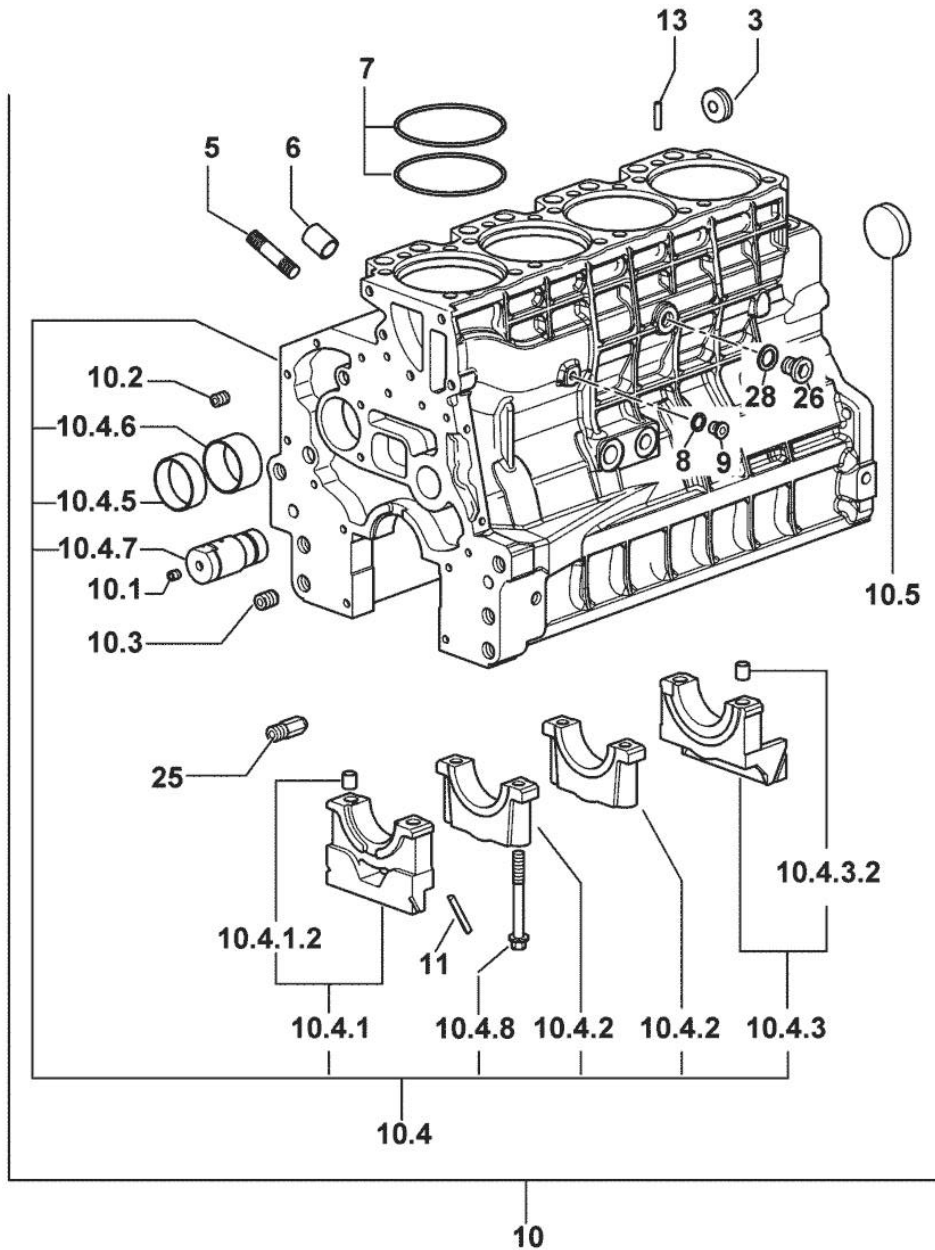

Fig.	P/n	QTY	Name
------	-----	-----	------

Notes:
 [H 90 XF]

3	2.3199.312.2/10	1	plug
5	2.0439.273.7	8	stud bolt m 8
6	2.1559.188.2	4	bush 11.4 x 14 x16
7	2.1539.193.0	8	special oil seal 107.62x2.62
8	2.1560.010.0	1	gasket 14.2 x 20
9	2.3199.292.0	1	plug 1/4" gas
10	0.013.0489.4/30	1	crankcase
10.1	2.3130.001.1	10	plug 1/8" gas
10.2	2.3130.002.1	2	plug 1/4" gas
10.3	2.3130.003.1	6	plug 3/8" gas
10.4	0.000.0000.1		cannot be supplied
10.4.1	0.065.1112.7	1	support
10.4.1.2	2.1699.165.0	1	bush 12.3x15x16
10.4.2	0.065.1114.0/10	3	support
10.4.3	0.065.1116.3	1	support
10.4.3.2	2.1699.165.0	1	bush 12.3x15x16
10.4.5	0.065.1140.0	4	special bushing 59X55X20
10.4.6	0.065.1141.0	1	special bushing 59X55X30
10.4.7	0.066.1151.0	1	pin
10.4.8	0.065.1117.0	10	screw m 12 x 100
10.5	2.3179.012.0	1	plug 60
11	0.066.1152.0/10	4	gasket
13	2.1549.154.2	4	bush 4.8x5.8x16
25	0.013.4946.0/10	1	sprayer nozzle
26	2.3120.101.0	1	plug m 18 p.1.5
28	2.1560.014.0	1	washer 18.2 x 24

Section: ENGINE
TIMING CASE

Fig.	P/n	QTY	Name
------	-----	-----	------

Notes:
[H 90 XF]

4	2.0432.009.7	1	stud bolt m 8 p.1.25 / p. 1 x 35
15	2.0432.003.7	1	stud bolt m 8 p.1.25 / p.1 x 20
16	2.0312.214.2	7	screw m 8 p.1.25 x 40
17	2.1480.014.1	15	washer 8
18	0.013.4981.0	1	guard
19	0.065.1150.0/30	1	gasket
20	2.1470.004.2	4	lock washer 8
21	2.1011.405.2	2	nut m 8 p.1
22	2.0312.208.2	8	screw m 8 p.1.25 x 25
23	2.1529.167.0	1	oil seal

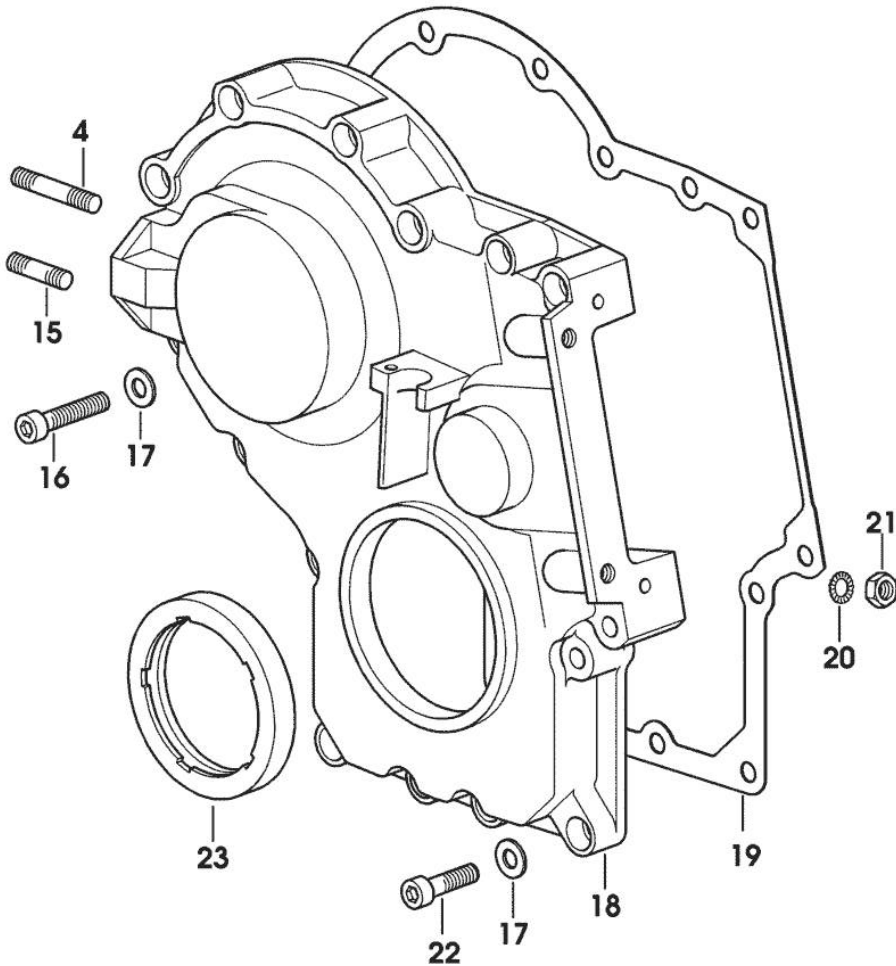

9_M8211_00_0_B

Section: ENGINE
GUARD PLATE

Fig.	P/n	QTY	Name
------	-----	-----	------

Notes:
[H 90 XF]

1	0.007.1262.3/50	1	guard
2	0.007.1271.0/10	1	small column m 8 p.1.25 / L = mm 60
3	0.007.1272.0/10	2	small column m 8 p.1.25 / L = mm 50
5	2.1310.004.2	3	flat washer 8.4x17
7	2.0112.203.2	3	screw m 8 p.1.25 x 12

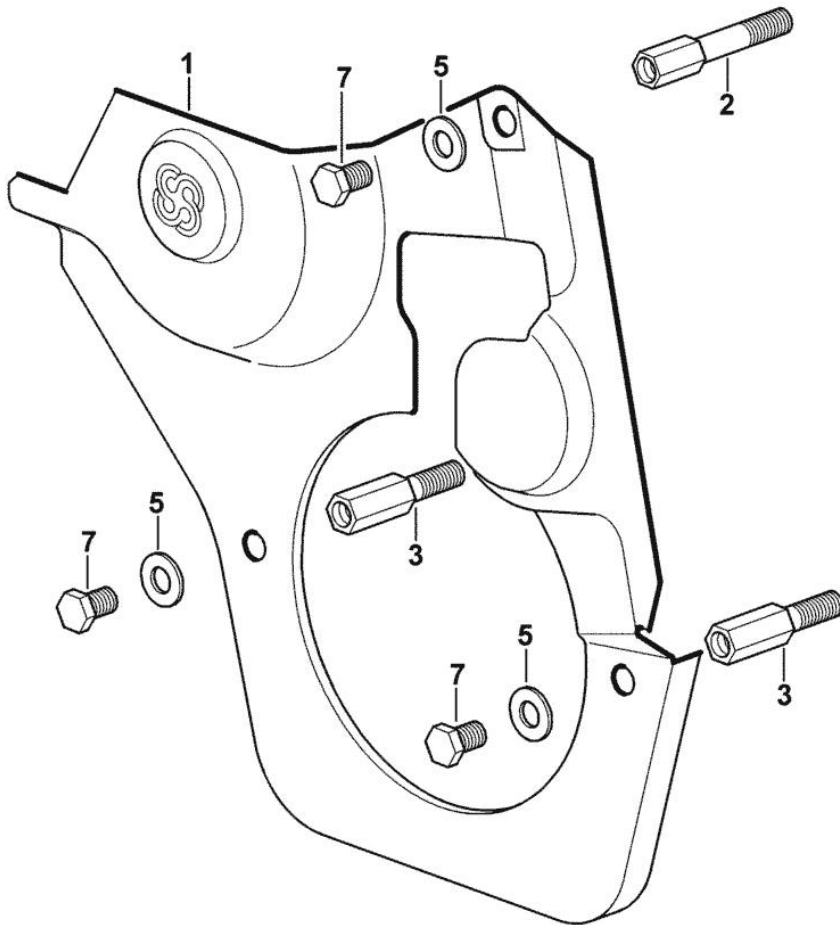

MONOBLOC ENGINE-GEARBOX CONNECTING FLANGE

Fig.	P/n	QTY	Name
------	-----	-----	------

Notes:
[H 90 XF]

6	2.0439.250.7	1	stud bolt m 12 / m 10 x 30
7	0.011.9294.0/10	1	bush
40	0.007.1414.0/10	1	flange
41	2.0112.511.2	8	screw m 14 p.2 x 30
42	2.1651.912.0	2	cylindrical plug 12x28
43	2.0432.257.7	1	stud bolt m 12 p.1.75 - 1.25 x 30
44	2.0312.516.2	2	screw m 14 x 50
45	2.1480.018.1	2	washer 14
46	2.3131.003.2	1	plug m 16 p.1.5

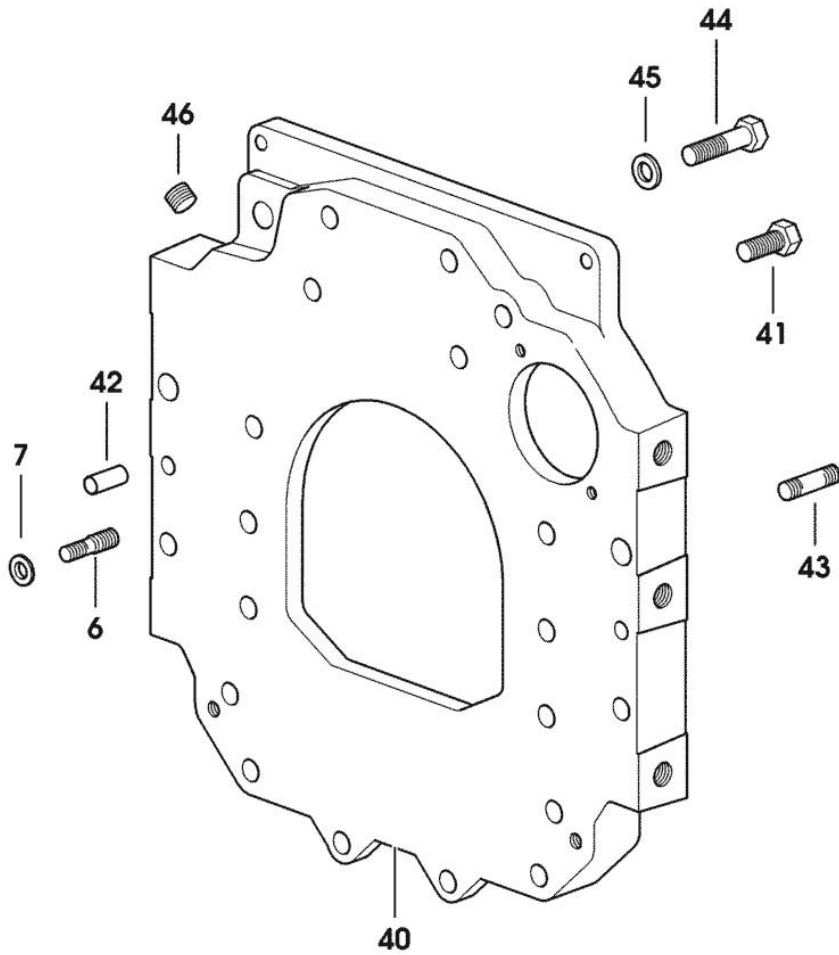

9_34811_03_0_0

Section: ENGINE

CRANKSHAFT

9_33212_00_0_0

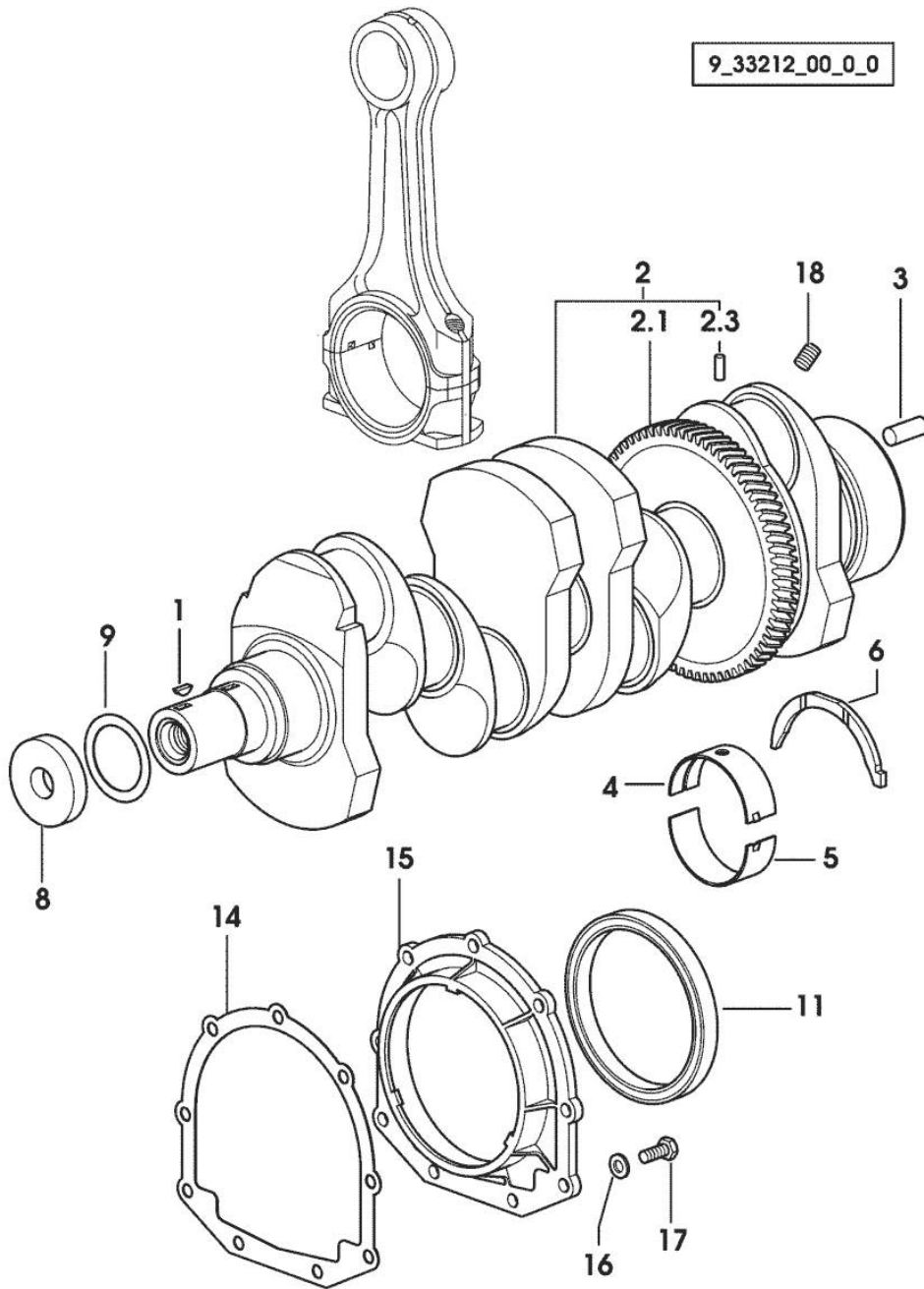

Fig.	P/n	QTY	Name
------	-----	-----	------

Notes:
[H 90 XF]

1	2.1720.006.0	1	key 4x6.5
2	0.086.1210.3/30	1	crankshaft
2.1	0.065.1211.0/10	1	crown wheel
2.3	2.1630.608.0	1	pin 6x16
3	2.1651.915.0	1	pin 12x35
4	0.065.1215.0	5	main half bushing STANDARD
4	0.065.1215.7		main half bushing - mm 0.25
4	0.065.1215.8		main half bushing - mm 0.50
5	0.065.1216.0	5	main half bushing
5	0.065.1216.7		main half bushing - mm 0.25
5	0.065.1216.8		main half bushing - mm 0.50
6	0.065.1218.0	4	shim STANDARD
6	0.065.1218.7		shim + mm 0.10
6	0.065.1218.8		shim + mm 0.15
8	2.1599.524.7	1	washer 21x60x12
9	2.1589.189.0	2	shoulder ring mm 1.00
11	2.1529.073.0	1	special oil seal 110x130x13
14	0.065.1254.0/20	1	gasket
15	0.007.1711.0/10	1	cover
16	2.1475.002.2	9	conical washer 8
17	2.0112.207.2	9	screw m 8 p 1.25 x 20
18	2.3130.001.1	4	plug 1/8" gas

CYLINDER - PISTON - CONNECTING ROD

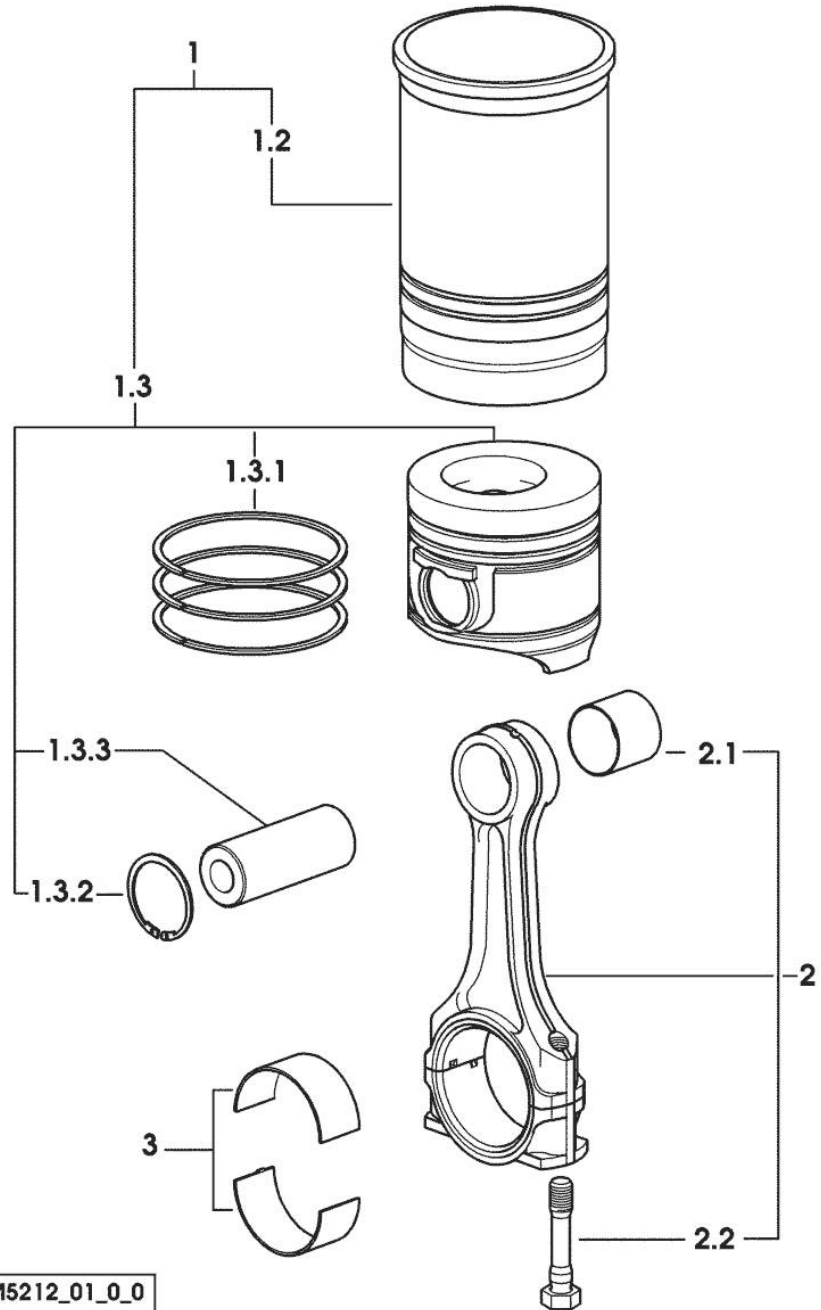

Fig.	P/n	QTY	Name
------	-----	-----	------

Notes:
[H 90 XF]

1	0.099.0065.A	4	cyl. piston assembly "A" - CLASS A
1	0.099.0065.B	4	cyl. piston assembly "B" - CLASS B
1.2	0.A12.2675.0	1	engine cylinder "A" - CLASS A
1.2	0.B12.2675.0	1	engine cylinder "B" - CLASS B
1.3	0.099.0060.A	1	complete piston "A" - CLASS A
1.3	0.099.0060.B	1	complete piston "B" - CLASS B
1.3.1	0.081.0090.6/10	1	piston ring set
1.3.2	2.1411.014.1	2	circlip 35
1.3.3	0.078.1236.0	1	piston pin Ø 18 / Ø 35 / L = mm 86
2	0.078.1220.3/30	4	engine connecting rod
2.1	2.1559.114.0/10	1	special bushing
2.2	2.0399.213.0	2	screw m 12 p.1.25x61.5
3	0.065.1225.0	8	con.rod half bushing STANDARD - A = 28.75 -> 29.00
3	0.065.1225.7	8	con.rod half bushing - mm 0.25
3	0.065.1225.8	8	con.rod half bushing - mm 0.50

9_M5212_01_0_0

Section: ENGINE

ENGINE FLYWHEEL

Fig.	P/n	QTY	Name
------	-----	-----	------

Notes:

[H 90 XF]

1	0.330.1250.0	6	screw m 12 p.1.25x98
2	0.332.1247.3/10	1	flywheel
2.2	0.065.1242.0	1	crown wheel Z = 123
3	2.2041.008.0	1	ball bearing 20x47x14

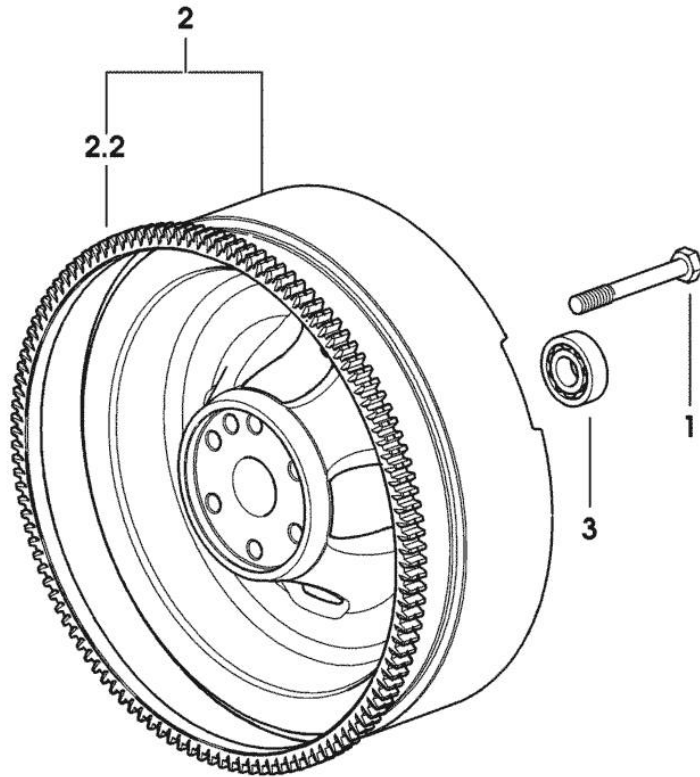

9_33212_08_0_0

Section: ENGINE

CRANKSHAFT PULLEY - FOR TRACTORS WITH AIR CONDITIONING

Fig.	P/n	QTY	Name
------	-----	-----	------

Notes:

[H 90 XF]

3	0.007.1458.0/40	1	pulley
5	0.085.1248.0/20	1	hub
6	2.0399.144.7	1	screw m 20 p.1.5x51
8	2.1720.006.0	1	key 4x6.5

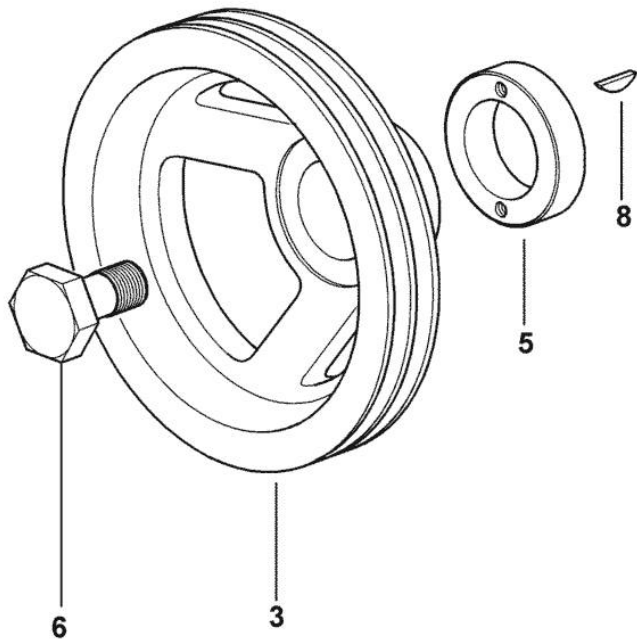

9_34512_06_0_0

CRANKSHAFT PULLEY - FOR TRACTORS WITHOUT AIR CONDITIONING

Fig.	P/n	QTY	Name
------	-----	-----	------

Notes:
[H 90 XF]

3	0.007.1457.0/30	1	pulley
5	0.085.1248.0/20	1	hub
6	2.0399.144.7/10	1	screw m 20 p.1.5x51
8	2.1720.006.0	1	key 4x6.5

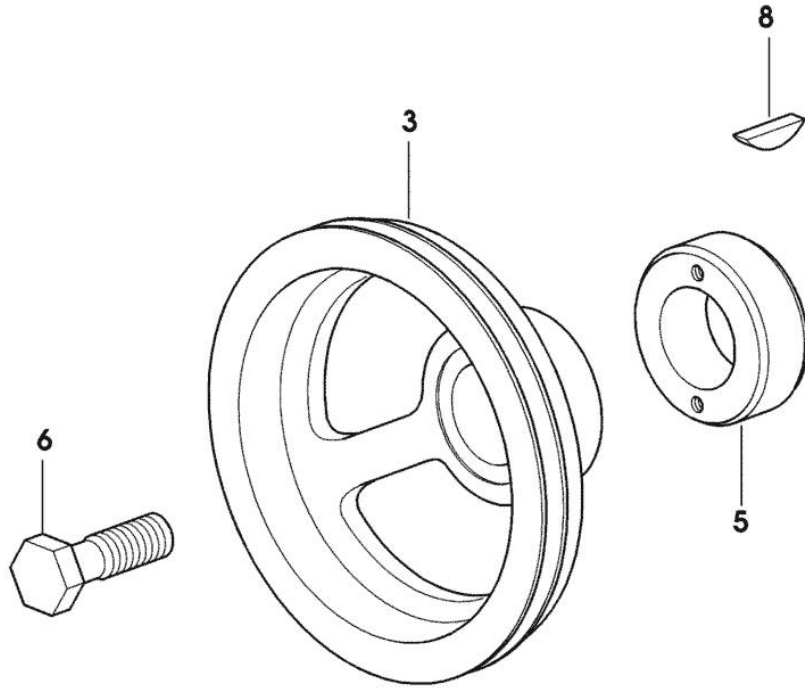

9_33312_02_0_0

Section: ENGINE
PULSE WHEEL

Fig.	P/n	QTY	Name
------	-----	-----	------

Notes:
[H 90 XF]

1	0.011.3531.0	1	gear Z = 48
---	--------------	---	-------------

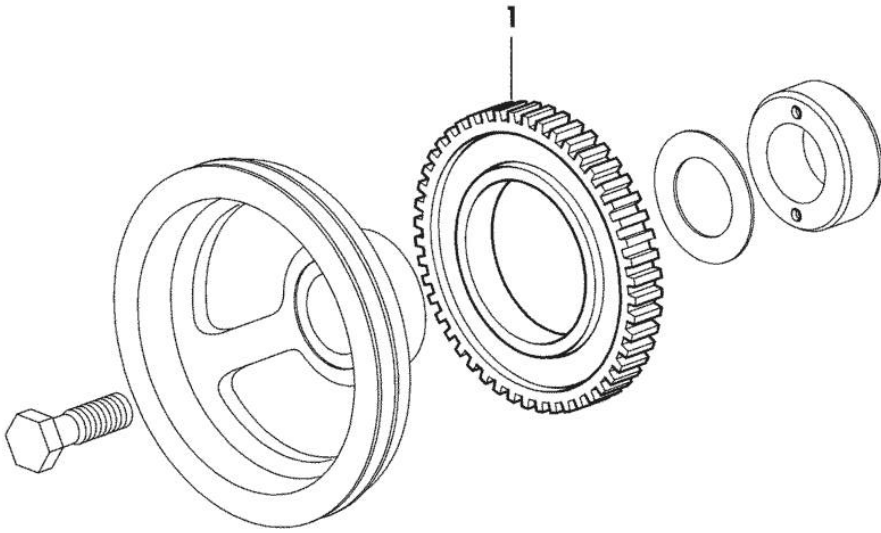

9_36812_05_0_0

PROVISION FOR FRONT PTO MOUNTING

Fig.	P/n	QTY	Name
------	-----	-----	------

Notes:

[H 90 XF]

1	0.082.1244.0/10	1	pulley
2	0.011.3515.0/20	1	hub Z = 48
3	0.065.1256.0	2	ring 45x52
4	2.1579.865.0	1	spacer 45.2x51.8x10
5	2.0439.195.7	1	stud bolt m 20 p.1.5x80
6	2.1019.094.7	1	nut m 20 p.1.5

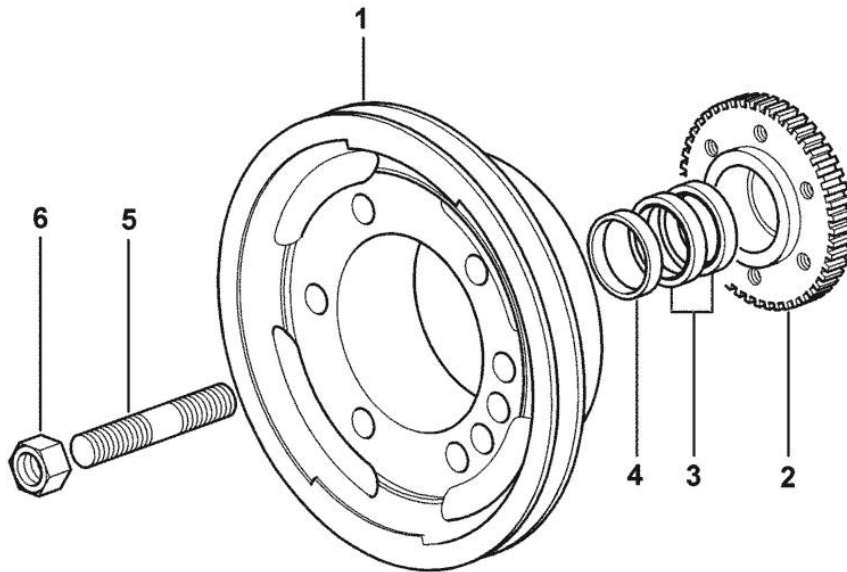

9_34512_07_0_0

Section: ENGINE

PREDISPOSITION FOR FRONT PTO (MODELS WITH AIR CONDITIONING)

Fig.	P/n	QTY	Name
------	-----	-----	------

Notes:

[H 90 XF]

1	0.082.1250.0/10	1	pulley
2	0.011.3515.0/20	1	hub Z = 48
3	0.065.1256.0	2	ring 45x52
4	2.1579.865.0	1	spacer 45.2x51.8x10
5	2.0439.195.7	1	stud bolt m 20 p.1.5x80
6	2.1019.094.7	1	nut m 20 p.1.5
7	2.1589.137.0	3	shoulder ring 71x110x1
8	0.089.1253.0/10	1	spacer

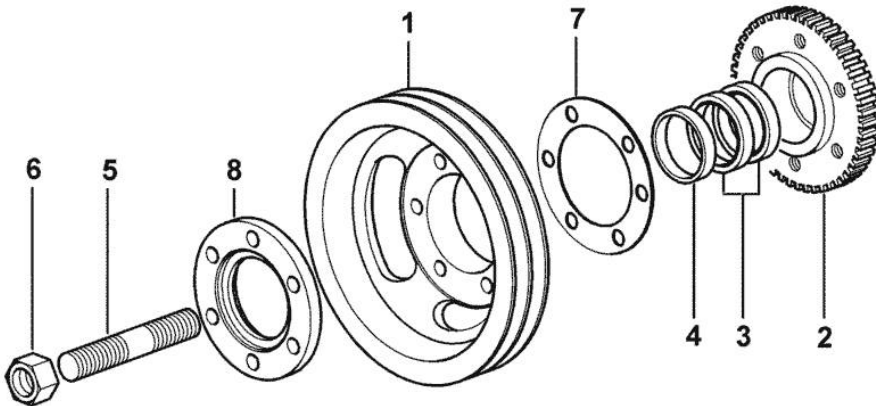

9_34512_08_0_0

Section: ENGINE
COUNTERWEIGHTS

Fig.	P/n	QTY	Name
------	-----	-----	------

Notes:
 [H 90 XF]

25	2.1589.139.0	1	shoulder ring mm 0.3
26	2.1589.140.0	3	shoulder ring mm 0.1
29	2.1579.628.0	3	spacer 16.5x26x0.1
33	2.1579.629.0	6	spacer 12.5x26x0.1
34	2.1589.048.0	1	shoulder ring 16.5x26x0.3
35	2.1589.049.0	1	shoulder ring 12.5x26x0.3
40	0.086.1233.3/30	1	mass sx/lh/li
40.2	2.1559.115.0	2	special bushing 26x30x30
40.3	0.000.0000.1		cannot be supplied
40.4	2.1651.302.0	1	roll pin 4x6
41	0.065.1233.3/30	1	mass dx/rh/re
41.2	2.1559.115.0	2	special bushing 26x30x30
41.3	0.000.0000.1		cannot be supplied
41.99	0.000.0000.1		cannot be supplied
41.99.4	2.1651.302.0	1	roll pin 4x6
41.99.5	2.1410.018.7	1	circlip 45
42	0.000.0000.1		cannot be supplied
42.1	0.086.1231.0/10	1	box
42.2	2.3130.001.1	4	plug 1/8" gas
43	2.1631.717.0	2	roll pin 8 x 40
44	2.1579.626.0	2	spacer 13.2x16x11
45	2.0139.028.2	4	screw m 12
46	2.1699.191.0	1	bush 7x10x16
47	0.000.0000.1		cannot be supplied
47.1	0.065.1234.0/10	1	shaft
47.2	2.3130.001.1	1	plug 1/8" gas
48	2.1589.185.0	4	shoulder ring 26.1x34x1

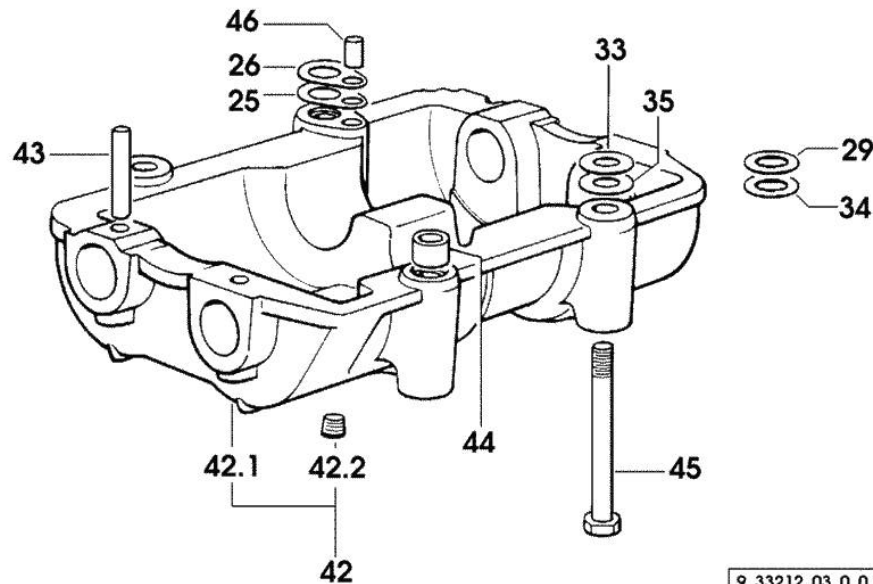
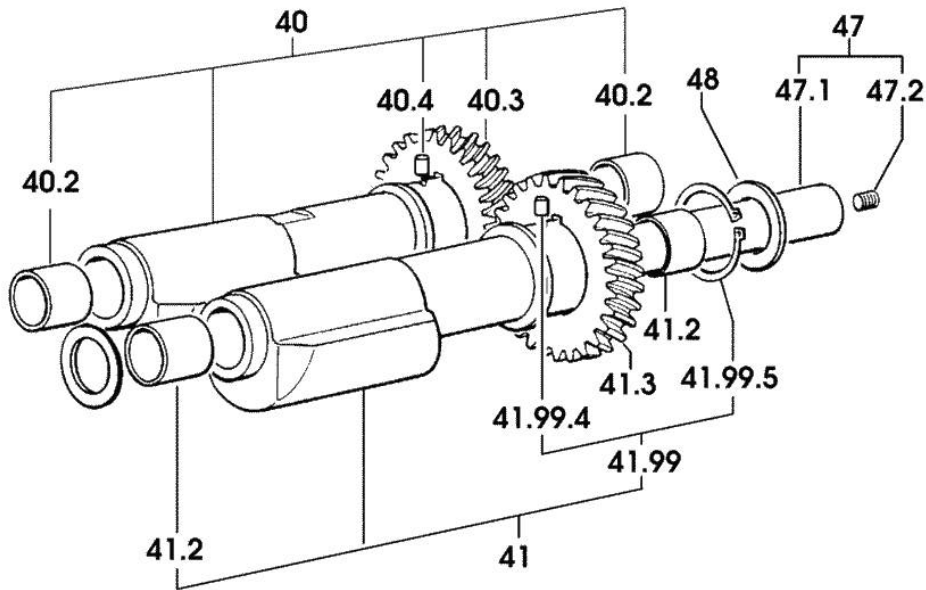

9_33212_03_0_0

Section: ENGINE

CAMSHAFT

Fig.	P/n	QTY	Name
------	-----	-----	------

Notes:
[H 90 XF]

1	0.065.1331.2	8	rod
2	0.012.6558.3/10	1	camshaft
2.2	0.065.1324.0/10	1	gear Z = 32
3	0.065.1330.0	8	tappets
4	2.1559.398.0	1	bushing 10.5x13x12
5	0.013.5017.0	1	gear z=58
6	0.065.1350.0	1	small disc
7	2.0132.207.2	4	screw m 10 p.1 x 25
8	2.1410.016.1	1	circlip 40
9	0.065.1352.0	1	shim
10	0.065.1351.0	2	shoulder ring
11	0.065.1323.0/30	1	gear Z = 29
12	0.007.1177.3/20		gear z = 57 - WITH RED IDENTIFICATION STAMP
12.2	2.1559.185.0/10	1	bushing gear z = 57 - WITH YELLOW IDENTIFICATION STAMP
13	0.007.1178.3/20		gear z = 57 - WITH YELLOW IDENTIFICATION STAMP
13.2	2.1559.185.0/10	1	bushing gear z = 57 - WITH GREEN IDENTIFICATION STAMP
14	0.007.1179.3/20		gear z = 57 - WITH GREEN IDENTIFICATION STAMP
14.2	2.1559.185.0/10	1	bushing
15	2.0312.205.2	2	screw
16	2.1480.014.1	2	washer 8
17	0.065.1353.0	1	small plate

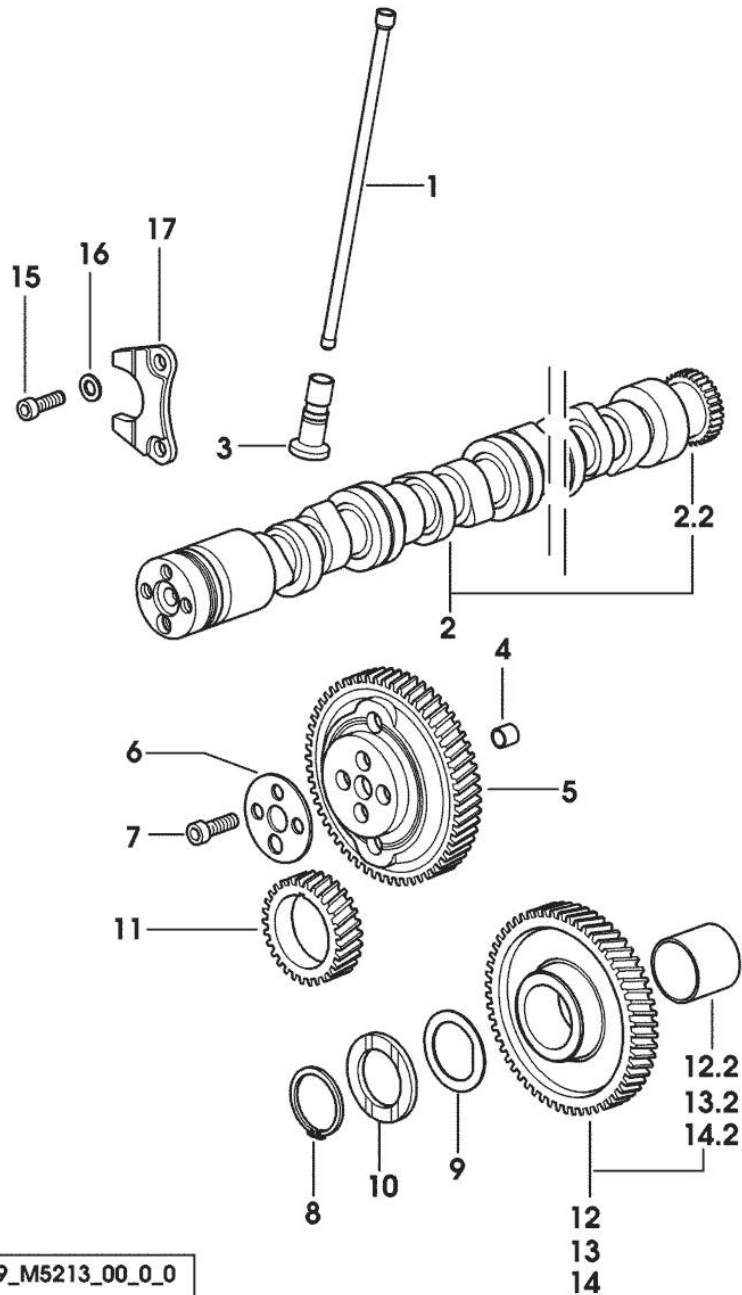

9_M5213_00_0_0

9_M5214_00_0_0

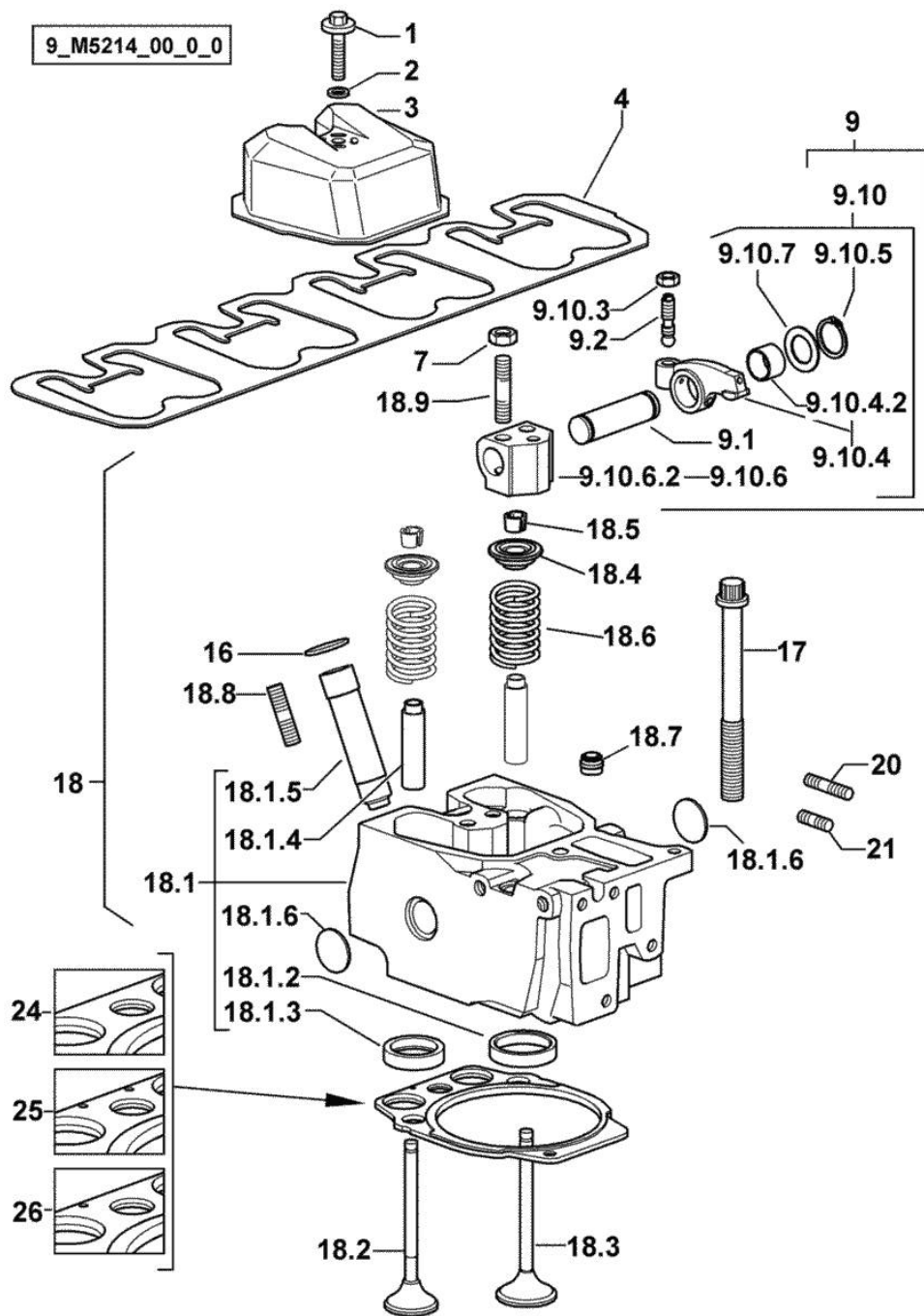

Section: ENGINE
CYLINDER HEAD

H 90 XF

Ref: 01.00.86

Fig.	P/n	QTY	Name
------	-----	-----	------

Notes:
[H 90 XF]

1	2.0399.288.2/10	4	screw m 8x36x46
2	2.1539.151.0	4	special oil seal 9.19 x 2.62
3	0.007.1139.0/10	4	small cap
4	0.065.1450.0/30	1	tappet gasket
7	2.1011.421.2	8	nut m 10 p.1.25
9	0.000.0000.1		cannot be supplied
9.1	0.066.1431.0	1	pin
9.2	0.021.1434.0	2	screw
9.10	0.000.0000.1		cannot be supplied
9.10.3	2.1011.405.2	2	nut m 8 p.1
9.10.4	0.066.1432.3	2	rocker arm
9.10.4.2	2.1559.021.0/40	1	bushing 15x19x22
9.10.5	2.1410.055.7	2	circlip 19
9.10.6	0.000.0000.1		cannot be supplied
9.10.6.2	0.066.1430.0/10	1	support
9.10.7	2.1599.432.0	2	shoulder ring
16	2.1532.507.0	4	oil seal 17x3.53
17	0.012.2673.0	16	screw m 14 p.2x141
18	0.000.0000.1		cannot be supplied
18.1	0.013.0412.3/60	1	engine head
18.1.2	0.078.1426.0	1	valve seat
18.1.3	0.066.1427.0	1	valve seat
18.1.4	0.007.1779.0/20	2	valve guide
18.1.5	0.012.9984.0/20	1	bush
18.1.6	2.3170.012.1	2	expansion plug 30
18.2	0.010.6022.0	1	exhaust valve mm 39.1 / Ø mm 9
18.3	0.010.6017.0	1	inlet valve mm 43.63 / Ø mm 9
18.4	0.066.1425.0	2	cup
18.5	0.074.1423.0	4	conical valve cotter
18.6	2.4019.287.0	2	spring
18.7	2.1519.117.0	2	special oil seal
18.8	2.0432.161.7	1	stud bolt m 10 p.1.5 / p.1.25 x 40
18.9	2.0432.163.7	2	stud bolt m 10 p.1.5 / p.1.25 x 45
20	2.0432.011.7	4	stud bolt m 8 p.1.25 / p.1 x 40
21	2.0432.005.7	4	stud bolt m 8 p.1.5 / p.1 x 25
24	0.013.1887.0		gasket
25	0.013.1888.0	3	gasket
26	0.013.1889.0		gasket

Thank you so much for reading.
Please click the “Buy Now!”
button below to download the
complete manual.



After you pay.

You can download the most
perfect and complete manual in
the world immediately.

Our support email:

ebooklibonline@outlook.com