

Section: ENGINE
CRANKCASE

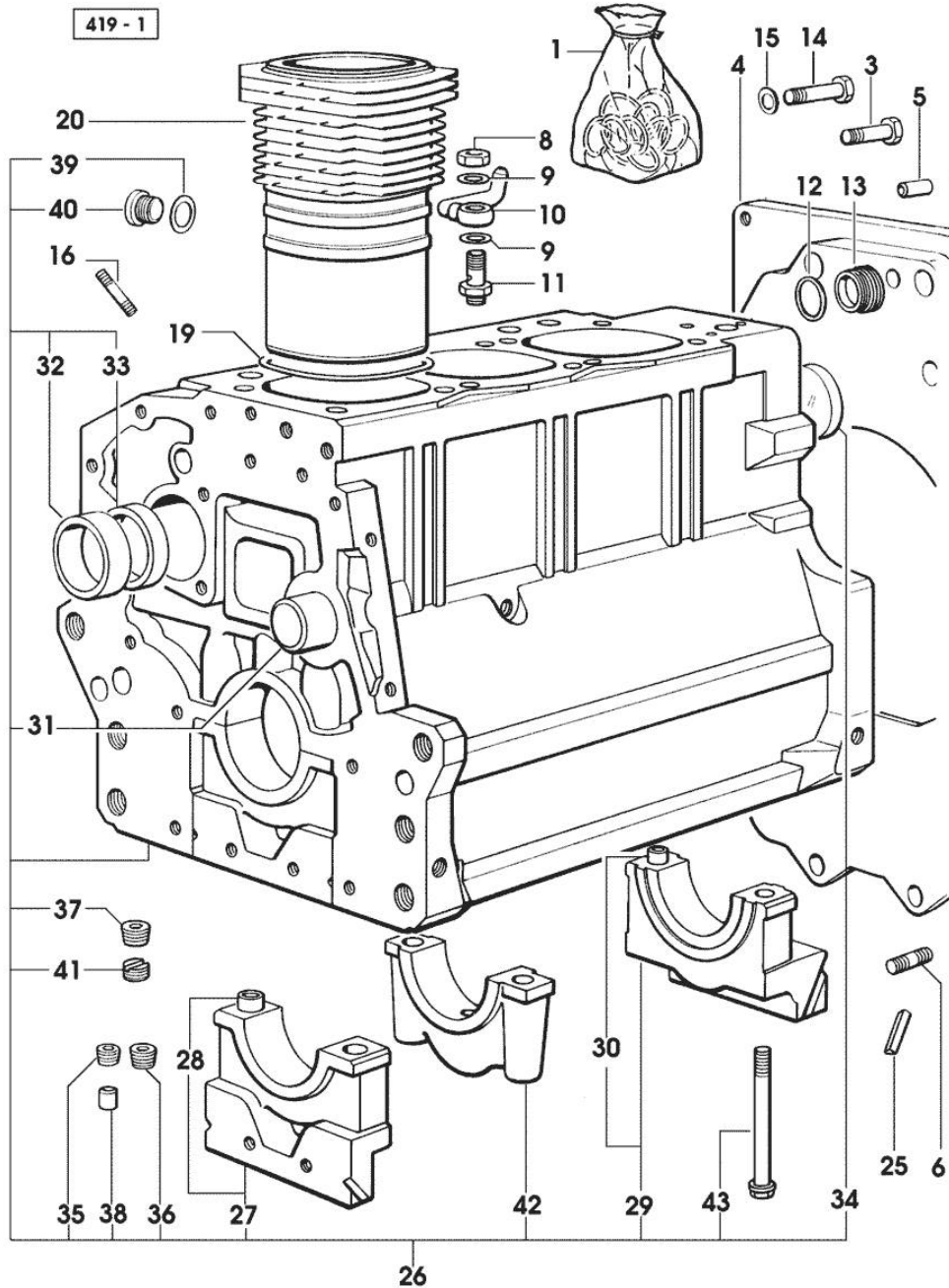
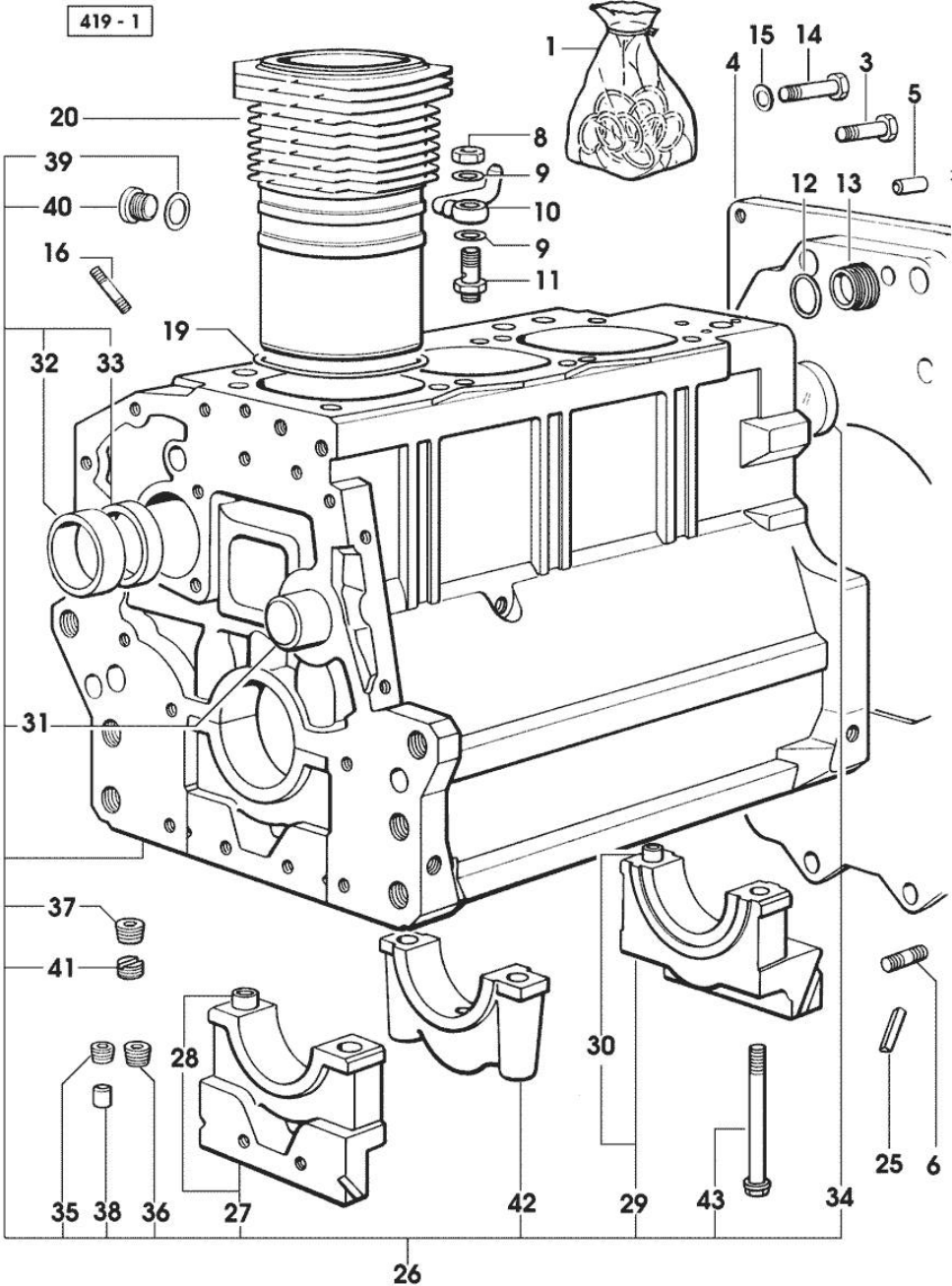

Fig.	P/n	QTY	Name
Notes: [H-372]			
1	0.085.0050.6/10	1	gasket set - X 60HP - FOR ENGINE MOUNTING
1	0.351.0050.6/10	1	gasket set - X 70HP - FOR ENGINE MOUNTING
3	2.0112.511.1	8	screw m 14 p.2 x 30
4	0.330.1130.0/10	1	flange
5	2.1651.912.0	2	cylindrical plug 12x28
6	2.0432.255.7	2	stud bolt m 12 p.1.75-1.25x25
8	2.1099.108.2	3	special nut m 10 p.1
9	2.1560.006.0	6	gasket 10.2 x 16
10	0.086.1550.2	3	sprayer nozzle
11	0.065.1160.3/20	3	valve
12	2.1539.047.0	1	special oil seal 26.7x1.78
13	2.3199.405.2	1	plug m 28 p.1.5
14	2.0312.516.1	2	screw m 14 p.2x50
15	2.1480.018.1	2	washer 14
16	2.0432.003.7	9	stud bolt m 8 p.1.25 / p.1 x 20
19	2.1519.096.0/10	3	oil seal 107.67x1.78 (...) <=
19	2.1539.130.0/10	3	special oil seal 117.07x3.53 => (...)
20	0.007.0762.0/50	3	engine cylinder => (...)
20	0.085.1120.0/10	3	engine cylinder (...) <=
25	0.066.1152.0	4	gasket
26	0.007.1150.6/10	1	crankcase => 12953 X 60HP => 2680 X 70HP
26	0.085.1110.6	1	crankcase 12952 <= X 60HP 2679 <= X 70HP
27	0.065.1112.7	1	support
28	2.1699.165.0	1	bush 12.3x15x16
29	0.065.1116.3	1	support
30	2.1699.165.0	1	bush 12.3x15x16
31	0.066.1151.0	1	pin
32	0.065.1141.0	1	special bushing 59X55X30
33	0.065.1140.0	3	special bushing 59X55X20

Section: ENGINE
CRANKCASE

Fig.	P/n	QTY	Name
34	2.3179.012.0	1	plug 60
35	2.3130.001.1	9	plug 1/8" gas
36	2.3130.002.1	2	plug 1/4" gas
37	2.3130.003.1	7	plug 3/8" gas
38	2.3199.092.0	3	plug 8 x 12
39	2.1560.017.0	1	gasket 22.2 x 27
40	2.3120.002.4	1	plug m 22 x 1.5
41	2.1324.011.0	1	plug
42	0.065.1114.0/10	2	support
43	0.065.1117.0	8	screw m 12 x 100



Section: ENGINE
TIMING CASE

Fig.	P/n	QTY	Name
------	-----	-----	------

Notes:
[H-372]

1	0.065.1132.0/60	1	guard
2	0.065.1150.0/30	1	gasket
3	2.0312.219.2	4	screw m 8 p.1.25x65
5	2.1470.004.2	4	lock washer 8
7	2.0432.003.2	2	stud bolt m 8 p.1x20
8	2.1011.405.2	2	nut m 8 p.1
9	2.0312.208.2	8	screw m 8 p.1.25 x 25
10	2.1480.014.1	15	washer 8
13	2.0312.214.2	3	screw m 8 p.1.25 x 40
14	2.1529.141.0	1	special oil seal

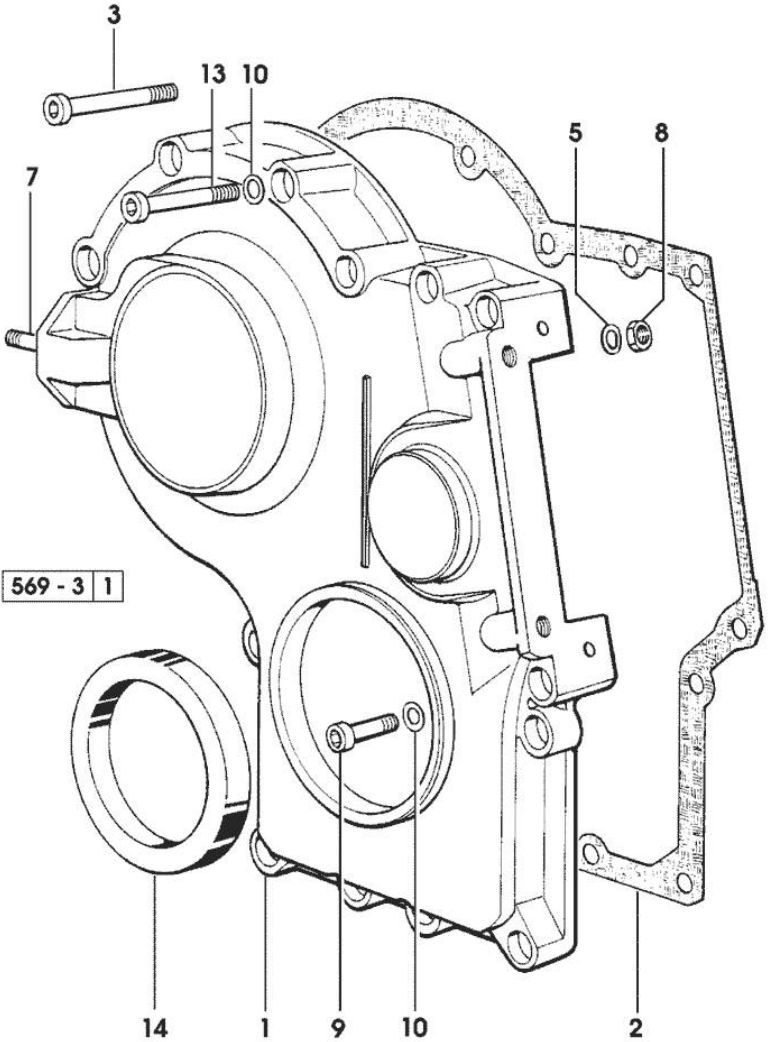

Section: ENGINE
TIMING CASE

Fig.	P/n	QTY	Name
------	-----	-----	------

Notes:
[H-372]

1	0.007.1262.3/50	1	guard
2	0.007.1271.0/10	1	small column m 8 p.1.25 / L = mm 60
3	0.007.1272.0/10	2	small column m 8 p.1.25 / L = mm 50
5	2.1310.004.2	3	flat washer 8.4x17
7	2.0112.205.2	3	screw m 8 p.1.25 x 16

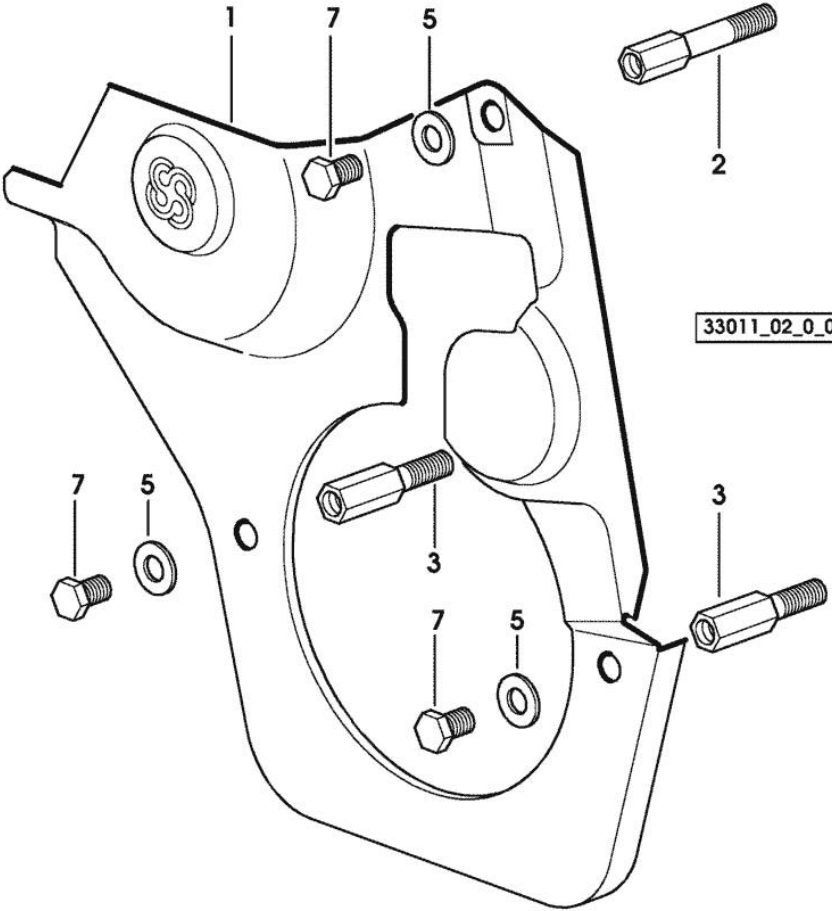

Section: ENGINE
CRANKSHAFT

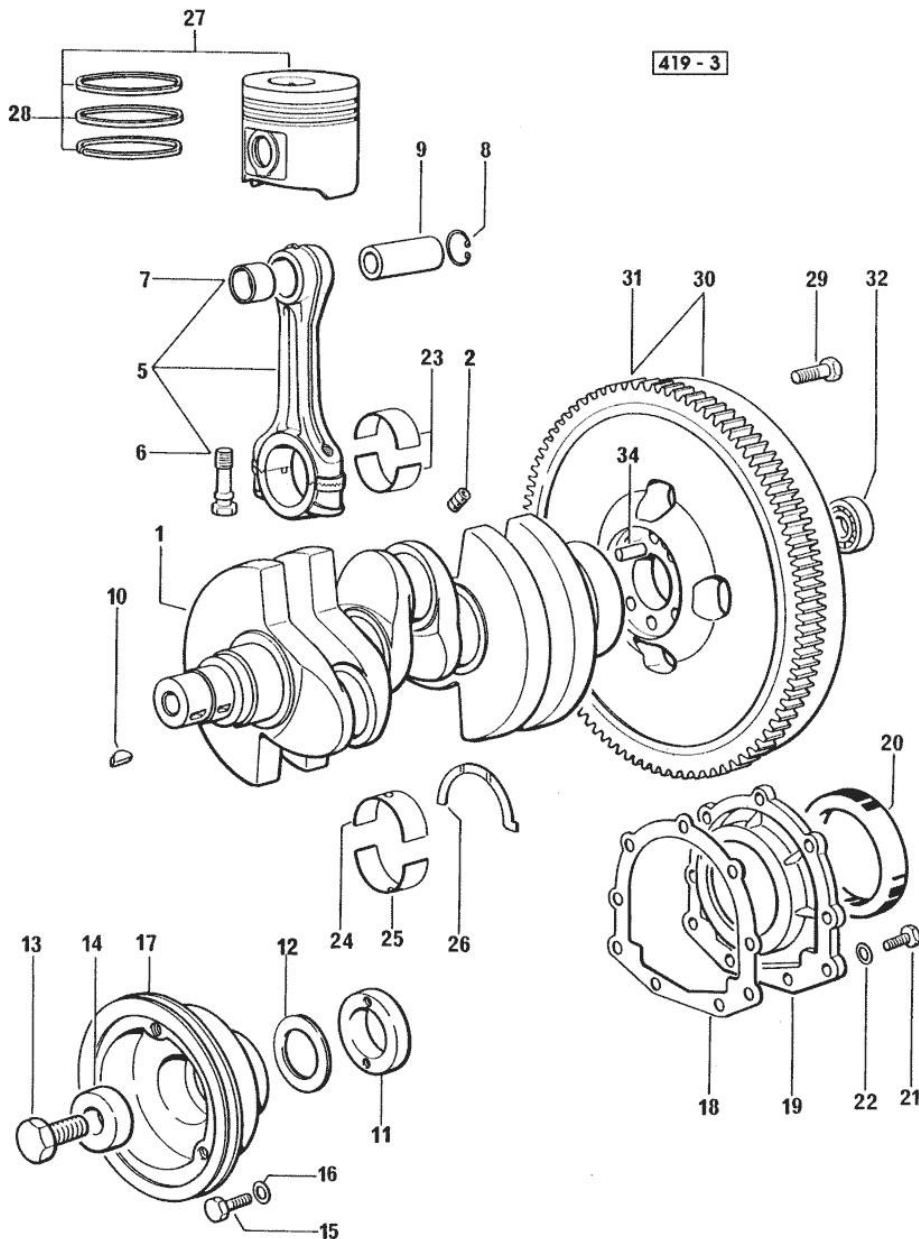

Fig.	P/n	QTY	Name
Notes: [H-372]			
1	0.007.1554.0/20	1	crankshaft * 14257 <= X 60HP * 2809 <= X 60HP - N.1 - 007.1711.0/10 - N.3 - 2.3130.001.1
2	2.3130.001.1	3	plug 1/8" gas
5	0.078.1220.3/30	3	engine connecting rod
6	2.0399.213.0	6	screw m 12 p.1.25x61.5
7	2.1559.114.0/10	3	special bushing
8	2.1411.014.1	6	circlip 35
9	0.078.1236.0	3	piston pin Ø 18 / Ø 35 / L = mm 86
10	2.1720.006.0	2	key 4x6.5
11	0.085.1248.0/10	1	hub
12	2.1589.189.0	3	shoulder ring mm 1.00
13	2.0399.144.7/10	1	screw m 20 p.1.5x51
14	2.1599.524.7	1	washer 21x60x12
15	2.0312.308.1	3	screw m 10 p.1.5 x 25
16	2.1480.015.1	3	washer 10
17	0.007.1330.0/30	1	pulley * (...)<= - N.2 - 2.1720.006.0
18	0.065.1254.0/20	1	gasket
19	0.007.1711.0/10	1	cover => 14258 X 60HP => 2810 X 70HP
19	0.065.1253.0/10	1	cover 14257 <= X 60HP 2809 <= X 70HP
20	2.1529.073.0	1	special oil seal 110x130x13
21	2.0112.207.2	9	screw m 8 p 1.25 x 20
22	2.1475.002.2	9	conical washer 8
23	0.065.1225.0	6	con.rod half bushing STANDARD - A = 28.75 -> 29.00
23	0.065.1225.7		con.rod half bushing - mm 0.25
23	0.065.1225.8		con.rod half bushing - mm 0.50
24	0.065.1215.0	4	main half bushing STANDARD
24	0.065.1215.7		main half bushing - mm 0.25
24	0.065.1215.8		main half bushing - mm 0.50
25	0.065.1216.0	4	main half bushing
25	0.065.1216.7		main half bushing - mm 0.25
25	0.065.1216.8		main half bushing - mm 0.50
26	0.065.1218.0	3	shim STANDARD
26	0.065.1218.7		shim + mm 0.10

Section: ENGINE
CRANKSHAFT

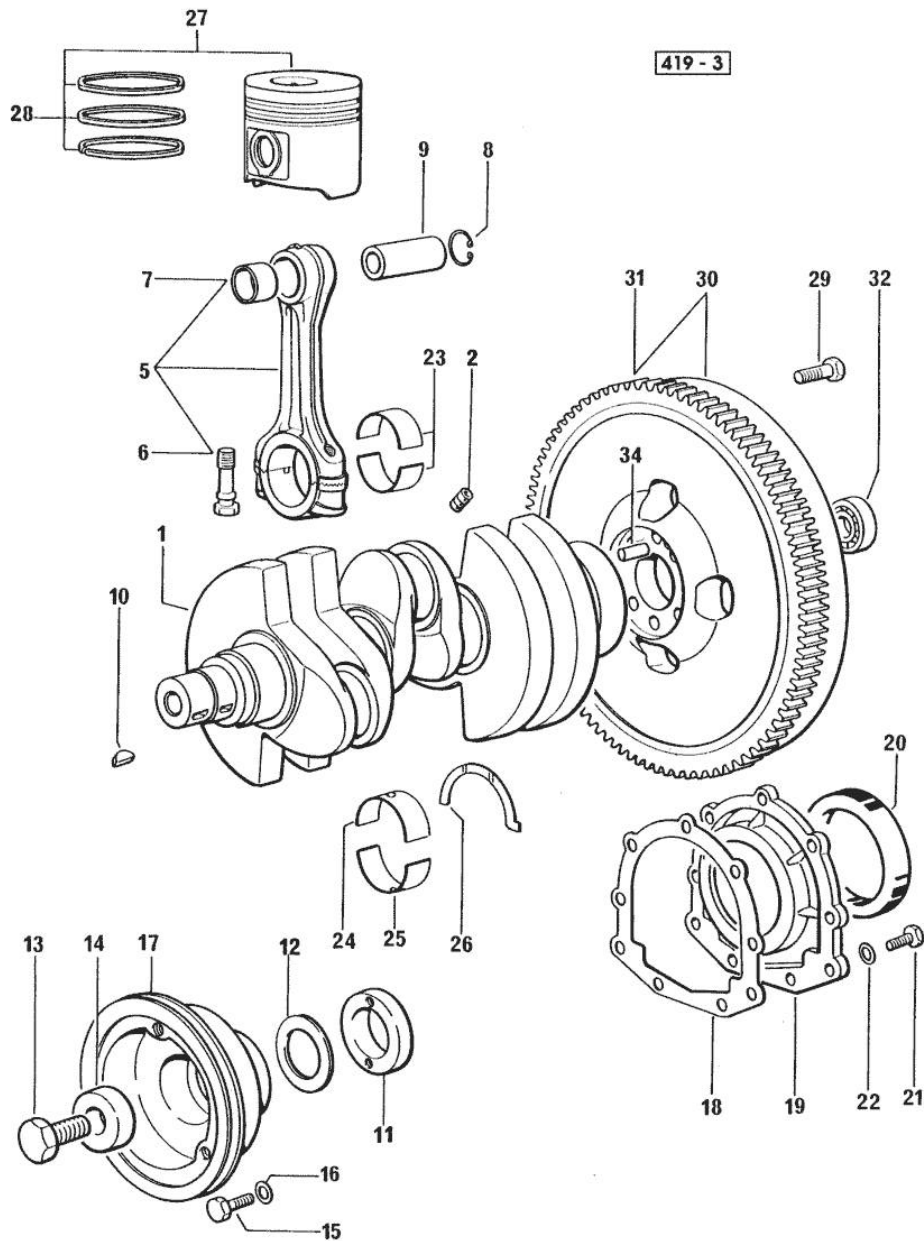

Fig.	P/n	QTY	Name
26	0.065.1218.8		shim + mm 0.15
27	0.086.0060.6/30	3	complete piston - X 60HP
27	0.338.0060.6/20	3	complete piston - X 70HP
28	0.081.0090.6/10	3	piston ring set (...) <= X 70HP - TORSIONAL
28	0.086.0052.6/10	3	piston ring set - X 60HP
28	0.338.0052.6/10	3	piston ring set => (...) X 70HP - TRAPEZOIDAL
29	0.330.1250.0	6	screw m 12 p.1.25x98
30	0.330.1247.3	1	flywheel
31	0.069.1242.0	1	crown wheel Z = 121
32	2.2041.008.0	1	ball bearing 20x47x14
34	2.1652.915.0	1	cylindrical plug 12x35

ENGINE SHAFT - FRONT P.T.O. PULLEYS

Fig.	P/n	QTY	Name
------	-----	-----	------

Notes:
[H-372]

1	0.086.1244.0	1	pulley
2	0.011.3515.0/10	1	hub Z = 48
3	0.065.1256.0	2	ring 45x52
4	2.1579.865.0	1	spacer 45.2x51.8x10
5	2.0439.195.7	1	stud bolt m 20 p.1.5x80
6	2.1019.094.7	1	nut m 20 p.1.5
7	2.1589.137.0	3	shoulder ring 71x110x1
8	2.1589.136.0	1	shoulder ring 71x110x0.5

419 - 3 - 1

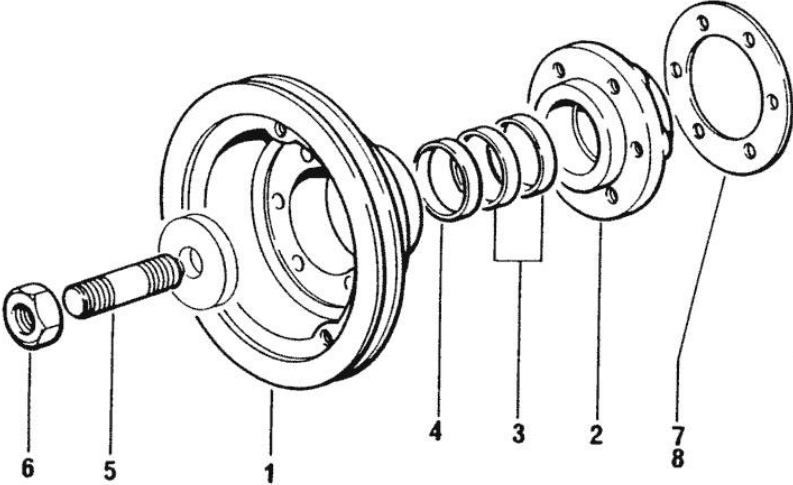

Section: ENGINE

CAMSHAFT

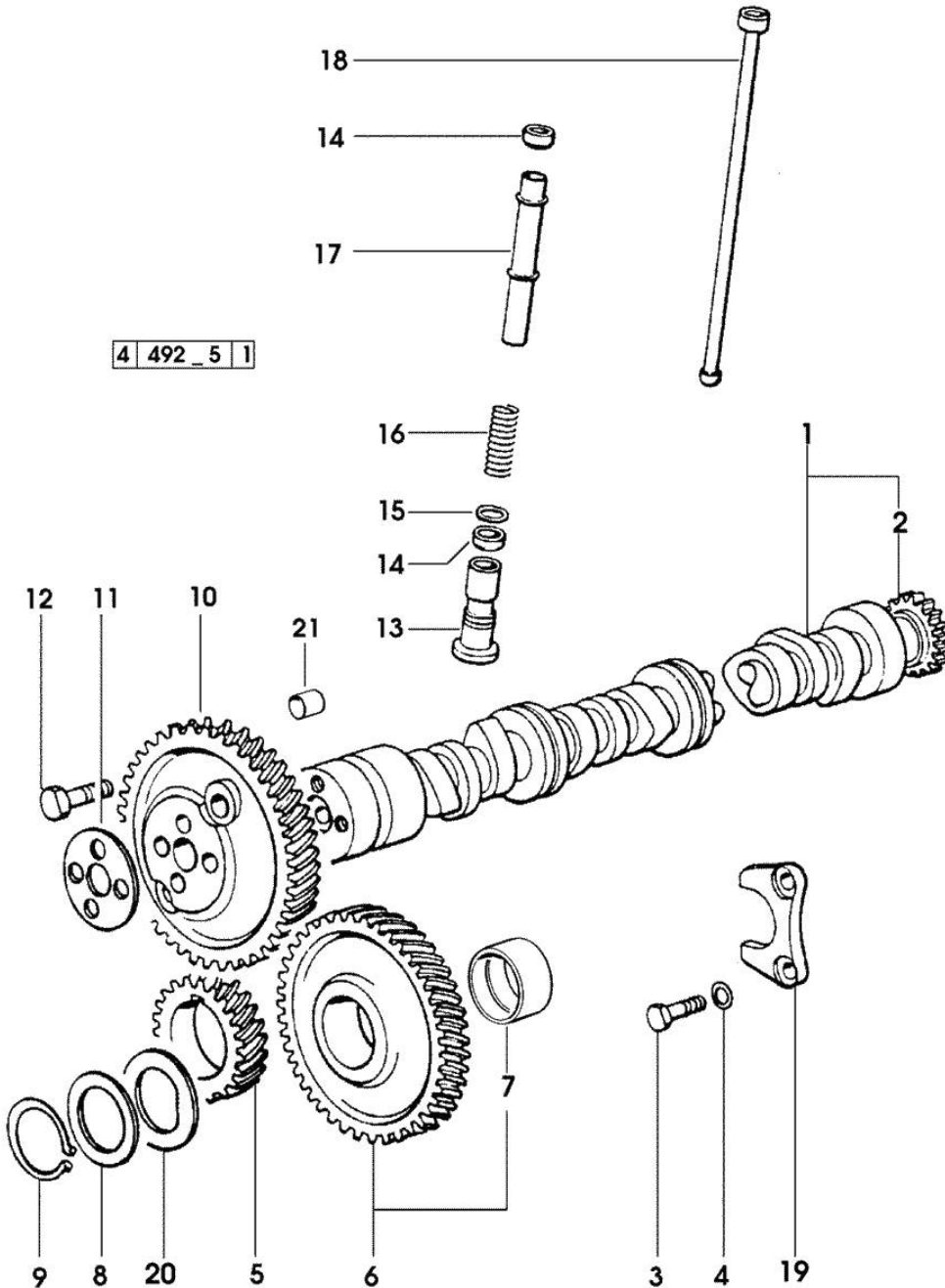
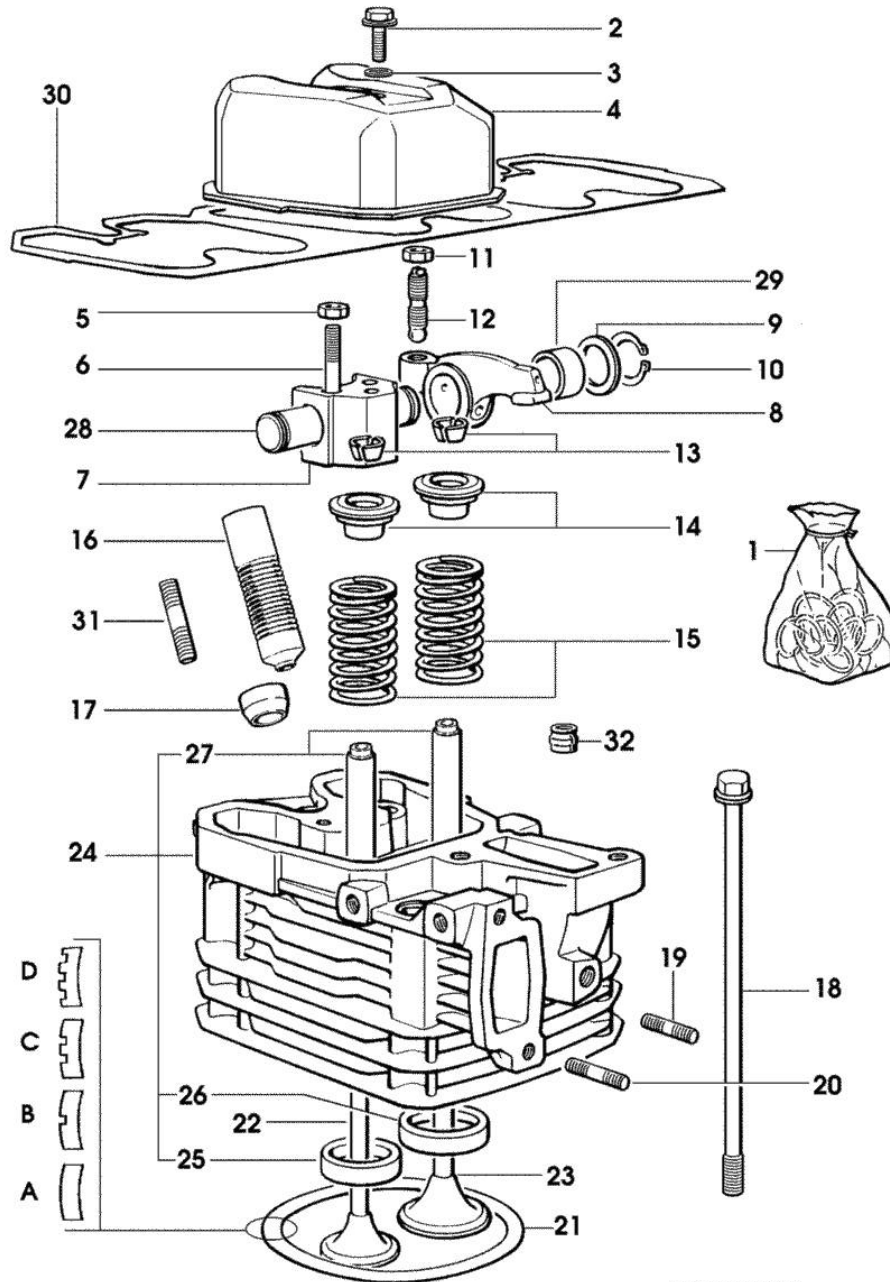

Fig.	P/n	QTY	Name
------	-----	-----	------

Notes:
[H-372]

1	0.070.1310.3/40	1	camshaft
2	0.065.1324.0/10	1	gear Z = 32
3	2.0312.206.2	2	screw m 8 p 1.25 x 20
4	2.1480.014.1	2	washer 8
5	0.065.1323.0/30	1	gear Z = 29
6	0.007.1177.3/10	1	gear z = 57 => (...) - WITH RED IDENTIFICATION STAMP
6	0.007.1178.3/10	1	gear z = 57 => (...) - WITH YELLOW IDENTIFICATION STAMP
6	0.007.1179.3/10	1	gear z = 57 => (...) - WITH GREEN IDENTIFICATION STAMP
6	0.065.1325.3/20	1	gear Z = 57 (...) <=
7	2.1559.185.0/10	1	bushing
8	0.065.1352.0	1	shim
9	2.1410.016.1	1	circlip 40
10	0.065.1354.0/20	1	gear z=58
11	0.065.1350.0	1	small disc
12	2.0132.207.2	4	screw m 10 p.1 x 25
13	0.065.1330.0	6	tappets
14	2.1569.114.0/10	12	gasket 14x18.5x8
15	2.1599.437.0	6	shoulder ring
16	2.4019.300.1/10	6	spring 18.5x52x2
17	0.065.1332.0	6	sleeve
18	0.065.1331.2	6	rod
19	0.065.1353.0	1	small plate
20	0.065.1351.0	2	shoulder ring
21	2.1559.398.0	1	bushing 10.5x13x12

Section: ENGINE
CYLINDER HEAD

2419_51

Fig.	P/n	QTY	Name
Notes: [H-372]			
1	0.085.0057.6/10	1	gasket set - FOR 1 CYLINDER VALVE GRINDING AND PISTON RINGS REPLACEMENT
2	2.0399.130.2	3	screw m 8 x 30 (...) <=
2	2.0399.130.2/10	3	screw m 8x36x44 => (...)
3	2.1569.170.0/10	3	gasket 8.2 x 14
4	0.007.1139.0/10	3	small cap * (...) <=
5	2.1011.421.2	6	nut m 10 p.1.25
6	2.0432.163.7	6	stud bolt m 10 p.1.5 / p.1.25 x 45
7	0.066.1430.0/10	3	support
8	0.066.1432.0	6	rocker arm
9	2.1599.432.0	6	shoulder ring
10	2.1410.055.1	6	circlip 19
11	2.1011.405.2	6	nut m 8 p.1
12	0.021.1434.0	6	screw
13	0.074.1423.0	6	conical valve cotter
14	0.066.1425.0	6	cup
15	2.4019.287.0	6	spring
16	0.065.1413.0/10	3	bush L = mm 97.1 (...) <=
17	0.007.1122.0/10	3	bush L = mm 6.4 => (...)
18	0.065.1443.0/20	12	screw
19	2.0432.007.2	4	stud bolt m 8 p.1.25 / p.1 x 30 - X 60HP
20	2.0432.021.7	2	stud bolt m 8 p.1.25 - 1.00 x 80 - X 70HP
21	0.085.1450.0	3	head gasket mm 0.5 -A-
21	0.085.1451.0	2	head gasket mm 0.7 -B-
21	0.085.1452.0	2	head gasket mm 1.0 -C-
21	0.085.1453.0	4	head gasket mm 0.8 -D-
22	0.066.1421.0	3	exhaust valve
23	0.078.1420.0	3	inlet valve - X 60HP
23	0.081.1420.0	3	inlet valve Ø mm 9 - X 70HP
24	0.007.1110.3/50	3	engine head

Section: ENGINE
CYLINDER HEAD

Fig.	P/n	QTY	Name
------	-----	-----	------

* (...)<=

- N.3 - 007.1122.0/10

25	0.066.1427.0	3	valve seat
26	0.078.1426.0	3	valve seat
27	0.007.1779.0/10	6	valve guide
28	0.066.1431.0	3	pin
29	2.1559.021.0/40	6	bushing 15x19x22
30	0.069.1450.0/30	1	tappet gasket
31	2.0432.161.7	3	stud bolt m 10 p.1.5 / p.1.25 x 40
32	2.1519.117.0	6	special oil seal

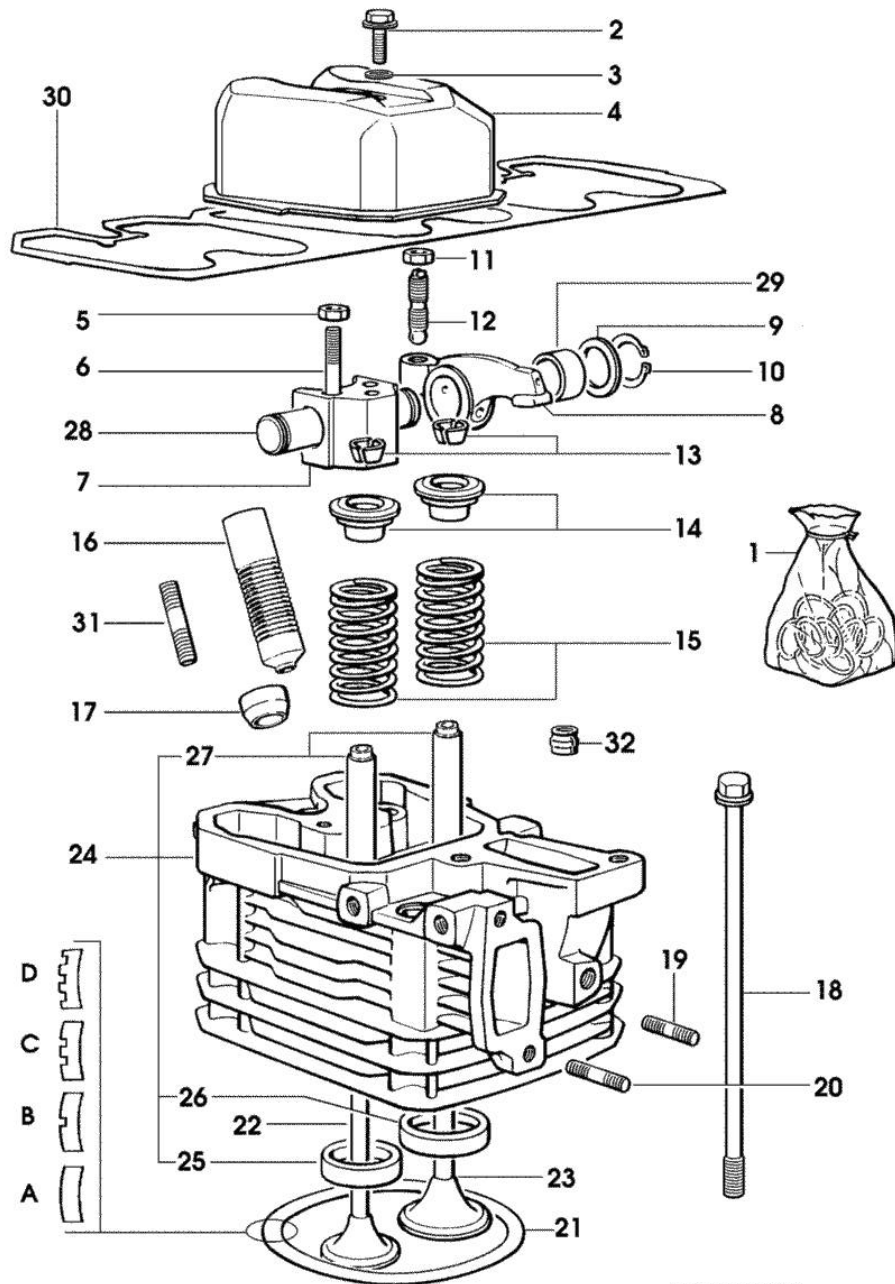

2419_51

Section: ENGINE
LUBRICATION

Fig.	P/n	QTY	Name
------	-----	-----	------

Notes:

=> (...) X 60HP [H-372]

1	0.007.1422.0/40	1	oil sump * (...) <= X 70HP - N.1 - 002.8816.0 - 007.1427.0
2	0.007.0614.0/10	1	gasket
3	2.3199.001.2	1	plug 1/2" gas
4	2.1560.054.0	1	gasket 21 x 26
5	2.0112.235.2	3	screw m 8 p.1.25 x 130 (...) <= X 70HP
6	2.0112.227.2	7	screw m 8 p.1.25 x 90
7	2.1475.002.7	22	washer 8.4
8	0.070.1531.3	1	tube
9	2.0112.209.2	1	screw m 8 p 1.25 x 25
10	2.1011.105.2	1	nut m 8 p.1.25
11	2.1470.004.2	1	lock washer 8
12	0.065.1538.0	1	flange
13	2.1539.040.0	1	special oil seal 21.82 x 3.53
14	2.0312.216.2	2	screw m 8 p.1.25x50
15	2.1310.004.2	2	flat washer 8.4x17
16	0.007.7319.3	1	oil cooler => (...)
16	0.085.1540.3	1	oil cooler (...) <=
17	2.1539.048.0	2	special oil seal 20.35x1.78
18	0.085.1513.2/20	1	dipstick
19	2.1539.065.0	2	special oil seal 8.73 x 1.78
20	2.3339.448.2	1	pipe union m 12 p.1.75 - X 60HP
21	2.3249.014.2	1	pipe fitting m 12 p.1.5 - X 60HP
22	2.1560.008.0	2	gasket 12.2 x 18 - X 60HP
23	0.044.1567.0	1	oil filter element - X 60HP
23	2.4419.340.0	1	oil filter element - X 70HP
24	2.3339.307.0	1	pipe fitting m 22 p.1.5-3/4"
25	2.0112.215.2	13	screw m 8 p.1.25 x 40
26	2.0112.411.2	4	screw m 12 p.1.75 x 30
27	2.1470.007.2	4	lock washer 12
28	2.0399.125.2/10	2	screw m 8 x 55
29	2.0112.720.1	4	screw m 18 p.2.5 x 55

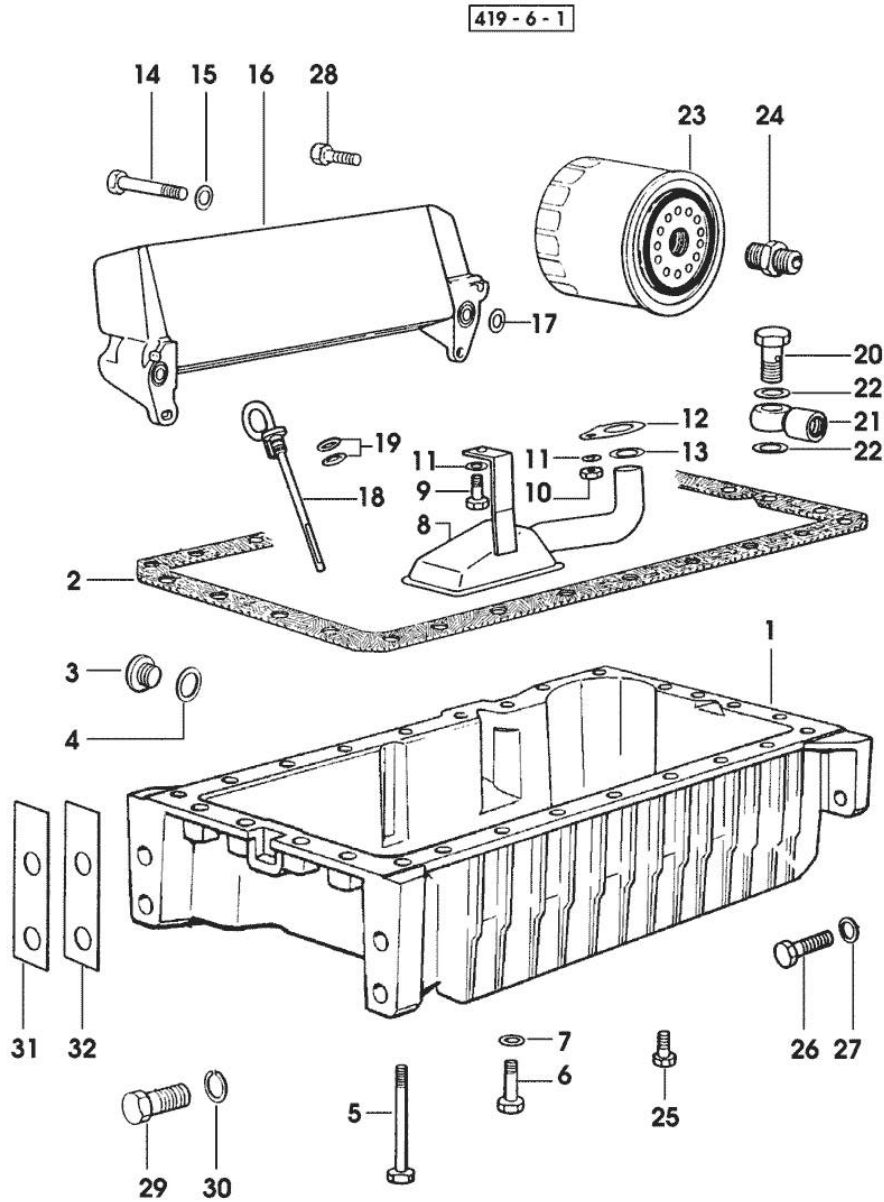

Thank you so much for reading.
Please click the “Buy Now!”
button below to download the
complete manual.



After you pay.

You can download the most
perfect and complete manual in
the world immediately.

Our support email:

ebooklibonline@outlook.com