

Section: ENGINE
CRANKCASE

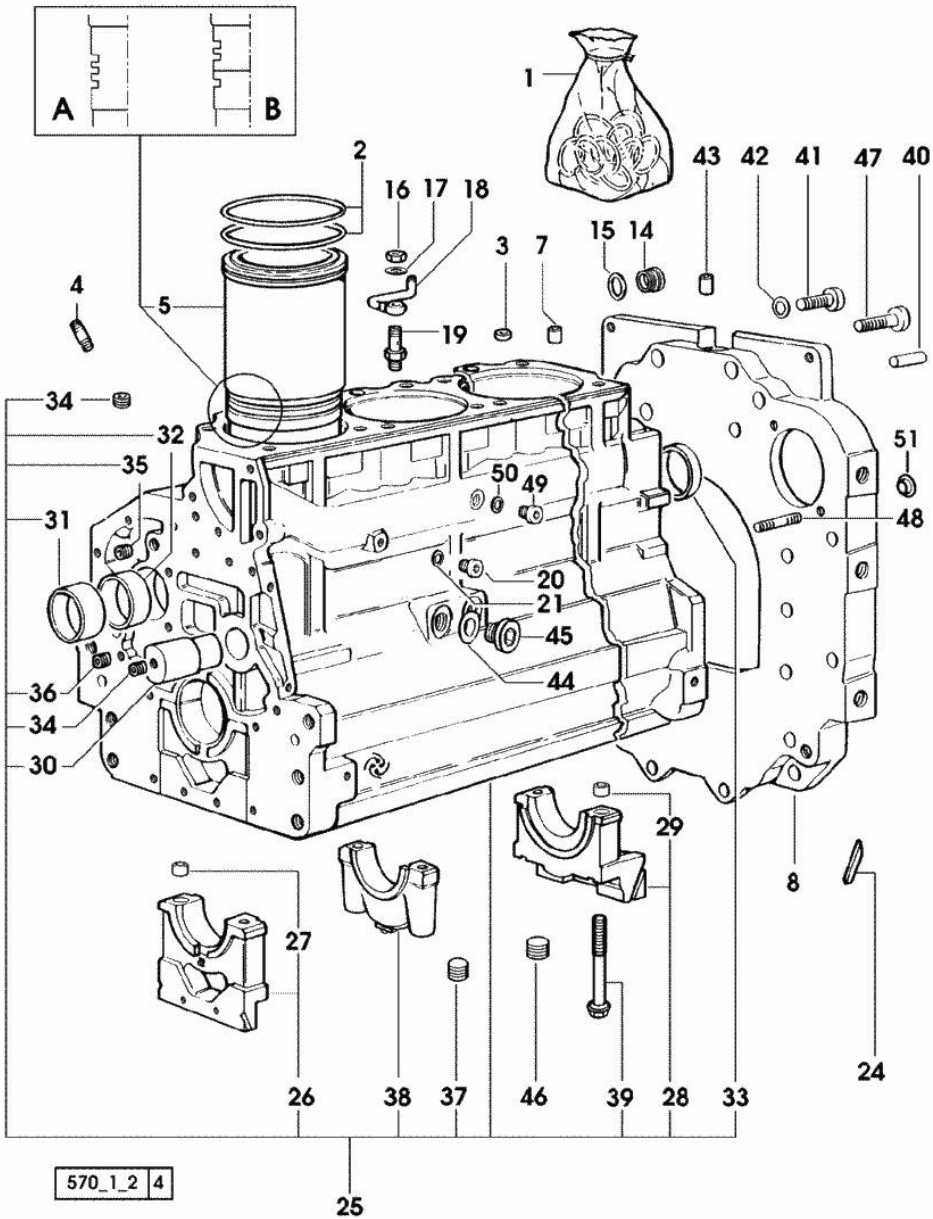

Fig.	P/n	QTY	Name
Notes: [H-491-XF]			
1	0.089.0050.6	1	gasket set - X H 481 XF - FOR ENGINE MOUNTING
1	0.090.0050.6	1	gasket set - X H 491 XF - FOR ENGINE MOUNTING
2	2.1519.096.0/20	12	special oil seal 107.67x1.78 2437<= X H 481 XF 2688 <= X H 491 XF
2	2.1539.193.0	8	special oil seal 107.62x2.62 => 2438 X H 481 XF => 2689 X H 491 XF
3	2.1559.188.2	4	bush 11.4 x 14 x16
4	2.0432.003.7	12	stud bolt m 8 p.1.25 / p.1 x 20
5	0.009.7500.0/10	4	engine cylinder = A 1120 <= X H 481 XF 1439 <= X H 491 XF
5	0.011.0582.0	4	engine cylinder = B => 1121 - 2437<= X H 481 XF => 1440 - 2688 <= X H 491 XF
5	0.A12.2675.0	4	engine cylinder "A" => 2438 X H 481 XF => 2689 X H 491 XF
5	0.B12.2675.0	4	engine cylinder "B" => 2438 X H 481 XF => 2689 X H 491 XF
7	2.1549.154.2	4	bush 4.8x5.8x16
8	0.007.1414.0/10	1	flange - FOR MODELS WITH ELECTRONIC ENGINE GOVERNOR
8	0.330.1130.0/10	1	flange - FOR MODELS WITH MECHANICAL ENGINE GOVERNOR
14	2.3199.405.2	1	plug m 28 p.1.5
15	2.1532.072.0	1	oil seal 26.70x1.78
16	2.1099.108.2	4	special nut m 10 p.1
17	2.1560.006.0	8	gasket 10.2 x 16
18	0.086.1550.2	4	sprayer nozzle
19	0.065.1160.3/20	4	valve

Section: ENGINE
CRANKCASE

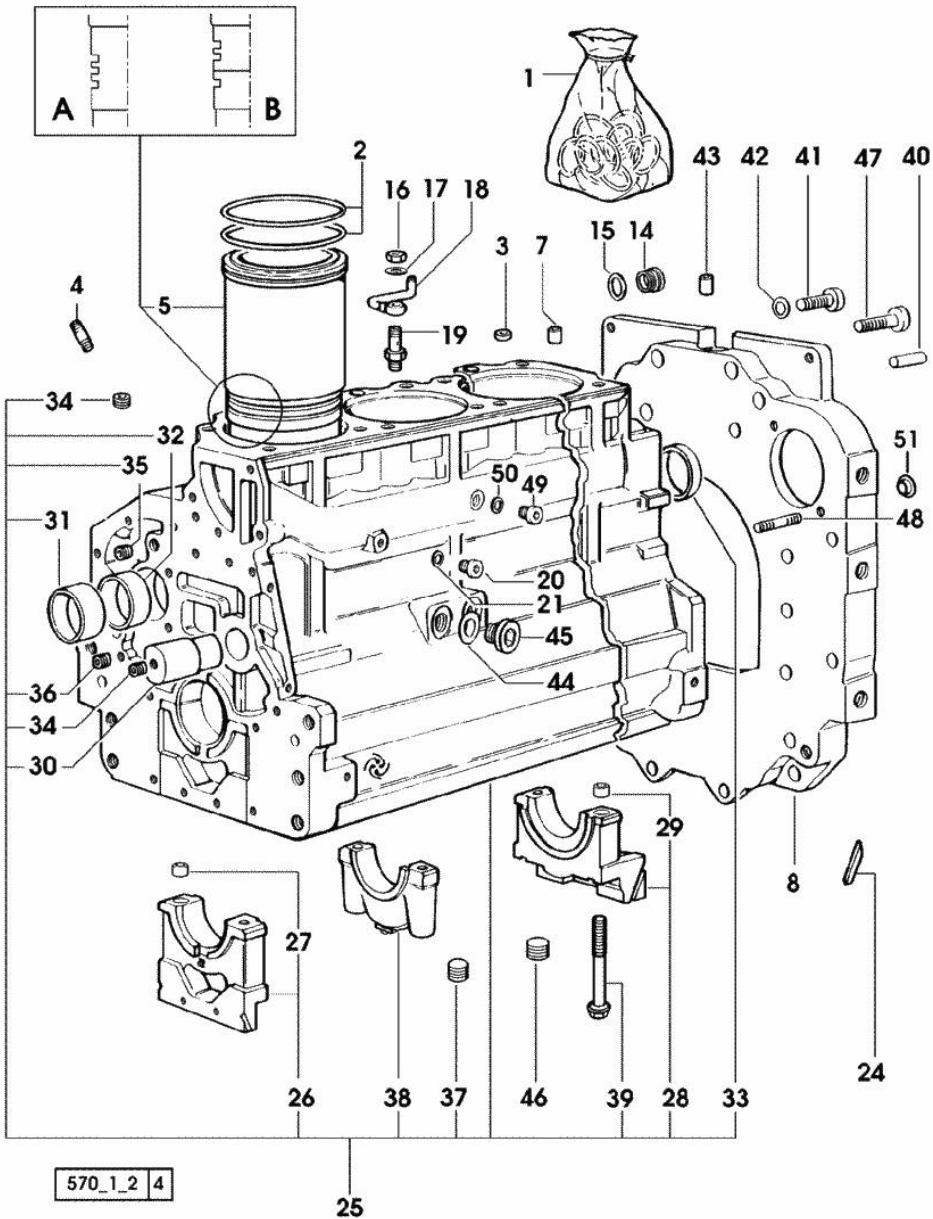

Fig.	P/n	QTY	Name
20	2.3199.292.0	1	plug 1/4" gas
21	2.1560.010.0	1	gasket 14.2 x 20
24	0.066.1152.0/10	4	gasket
25	0.082.1110.6/20	1	crankcase * 2437 <= X H 481 XF * 2688 <= X H 491 XF - N.4 011.0183.0/10 - N.8 2.1539.193.0
26	0.065.1112.7	1	support
27	2.1699.165.0	1	bush 12.3x15x16
28	0.065.1116.3	1	support
29	2.1699.165.0	1	bush 12.3x15x16
30	0.066.1151.0	1	pin
31	0.065.1141.0	1	special bushing 59X55X30
32	0.065.1140.0	4	special bushing 59X55X20
33	2.3179.012.0	1	plug 60
34	2.3130.001.1	11	plug 1/8" gas
35	2.3130.002.1	2	plug 1/4" gas
36	2.3130.003.1	5	plug 3/8" gas
37	2.1324.011.0	1	plug
38	0.065.1114.0/10	3	support
39	0.065.1117.0	10	screw m 12 x 100
40	2.1651.912.0	2	cylindrical plug 12x28
41	2.0312.516.1	2	screw m 14 p.2x50
42	2.1480.018.1	2	washer 14
43	2.1549.154.2	4	bush 4.8x5.8x16
44	2.1560.017.0	1	gasket 22.2 x 27
45	2.3120.002.4	1	plug m 22 x 1.5
46	2.3130.003.1	1	plug 3/8" gas
47	2.0112.511.1	8	screw m 14 p.2 x 30
48	2.0432.255.7	1	stud bolt m 12 p.1.75-1.25x25
48	2.0439.250.7	1	stud bolt m 12 / m 10 x 30
49	2.3120.101.0	1	plug m 18 p.1.5 => 2438 X H 481 XF => 2689 X H 491 XF
50	2.1560.014.0	1	washer 18.2 x 24
51	0.011.9294.0/10	1	bush

570_1_2 | 4

Section: ENGINE
TIMING CASE

Fig.	P/n	QTY	Name
------	-----	-----	------

Notes:
[H-491-XF]

1	0.007.1262.3/50	1	guard
2	0.007.1271.0/10	1	small column m 8 p.1.25 / L = mm 60
3	0.007.1272.0/10	2	small column m 8 p.1.25 / L = mm 50
5	2.1310.004.2	3	flat washer 8.4x17
7	2.0112.205.2	3	screw m 8 p.1.25 x 16

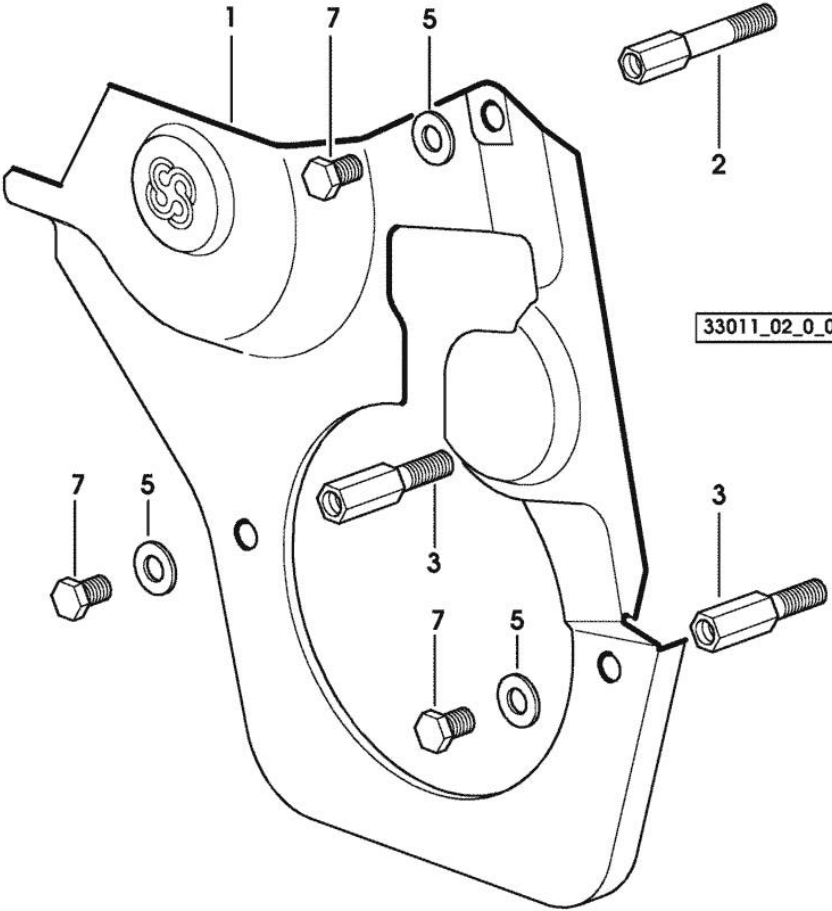

Section: ENGINE
TIMING CASE

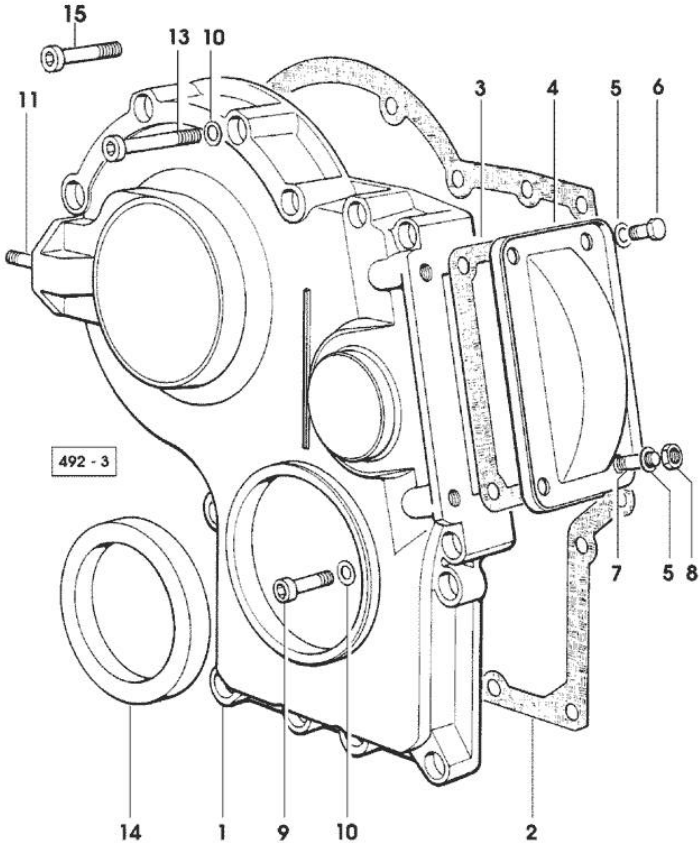

Fig.	P/n	QTY	Name
Notes:			
[H-491-XF]			
1	0.065.1132.0/60	1	guard
2	0.065.1150.0/30	1	gasket
3	0.065.1152.0	1	gasket
			- X H 481 H 491 XF
4	0.065.1151.0	1	cover
			- X H 481 H 491 XF
5	2.1470.004.2	4	lock washer 8
6	2.0112.205.2	2	screw m 8 p.1.25 x 16
7	2.0432.005.7	2	stud bolt m 8 p.1.5 / p.1 x 25
8	2.1011.405.2	2	nut m 8 p.1
9	2.0312.208.2	8	screw m 8 p.1.25 x 25
10	2.1480.014.1	15	washer 8
11	2.0432.003.7	2	stud bolt m 8 p.1.25 / p.1 x 20
13	2.0312.214.2	7	screw m 8 p.1.25 x 40
			- X H 476 H 481 H 491 XF
13	2.0312.219.2	4	screw m 8 p.1.25x65
			- X H 361 XF
14	2.1529.141.0	1	special oil seal
15	2.0312.214.1	3	screw m 8 p.1.25 x 40
			- X H 361 XF

Section: ENGINE
CRANKSHAFT

Fig.	P/n	QTY	Name
------	-----	-----	------

Notes:
 [H-491-XF]

1	0.086.1210.3/30	1	crankshaft * 1017 <= X H 491 XF - N.1 - 007.1711.0/10
2	0.065.1211.0/10	1	crown wheel
3	2.1630.608.0	1	pin 6x16
4	2.3130.001.1	4	plug 1/8" gas
5	0.078.1220.3/30	4	engine connecting rod
6	2.0399.213.0	2	screw m 12 p.1.25x61.5
7	2.1559.114.0/10	1	special bushing
8	0.330.1250.0	6	screw m 12 p.1.25x98
9	0.332.1247.3/10	1	flywheel
10	0.065.1242.0	1	crown wheel Z = 123
11	0.085.1248.0/10	1	hub
12	2.2041.008.0	1	ball bearing 20x47x14
13	2.0399.144.7/10	1	screw m 20 p.1.5x51
14	2.1599.524.7	1	washer 21x60x12
17	0.007.1457.0/20	1	pulley
17	0.007.1458.0/30	1	pulley - FOR TRACTORS WITH AIR CONDITIONING
18	0.065.1254.0/20	1	gasket
19	0.007.1711.0/10	1	cover => 1001 X H 481 XF => 1018 X H 491 XF
19	0.065.1253.0/10	1	cover 1017 <= X H 491 XF
20	2.1529.073.0	1	special oil seal 110x130x13
21	2.0112.207.2	9	screw m 8 p 1.25 x 20
22	2.1475.002.2	9	conical washer 8
23	0.065.1225.0	8	con.rod half bushing STANDARD - A = 28.75 -> 29.00
23	0.065.1225.7		con.rod half bushing - mm 0.25
23	0.065.1225.8		con.rod half bushing - mm 0.50
24	0.065.1215.0	5	main half bushing STANDARD
24	0.065.1215.7		main half bushing - mm 0.25
24	0.065.1215.8		main half bushing - mm 0.50
25	0.065.1216.0	5	main half bushing
25	0.065.1216.7		main half bushing - mm 0.25
25	0.065.1216.8		main half bushing - mm 0.50
26	0.065.1218.0	4	shim STANDARD
26	0.065.1218.7		shim + mm 0.10
26	0.065.1218.8		shim + mm 0.15
27	0.086.0060.6/30	4	complete piston

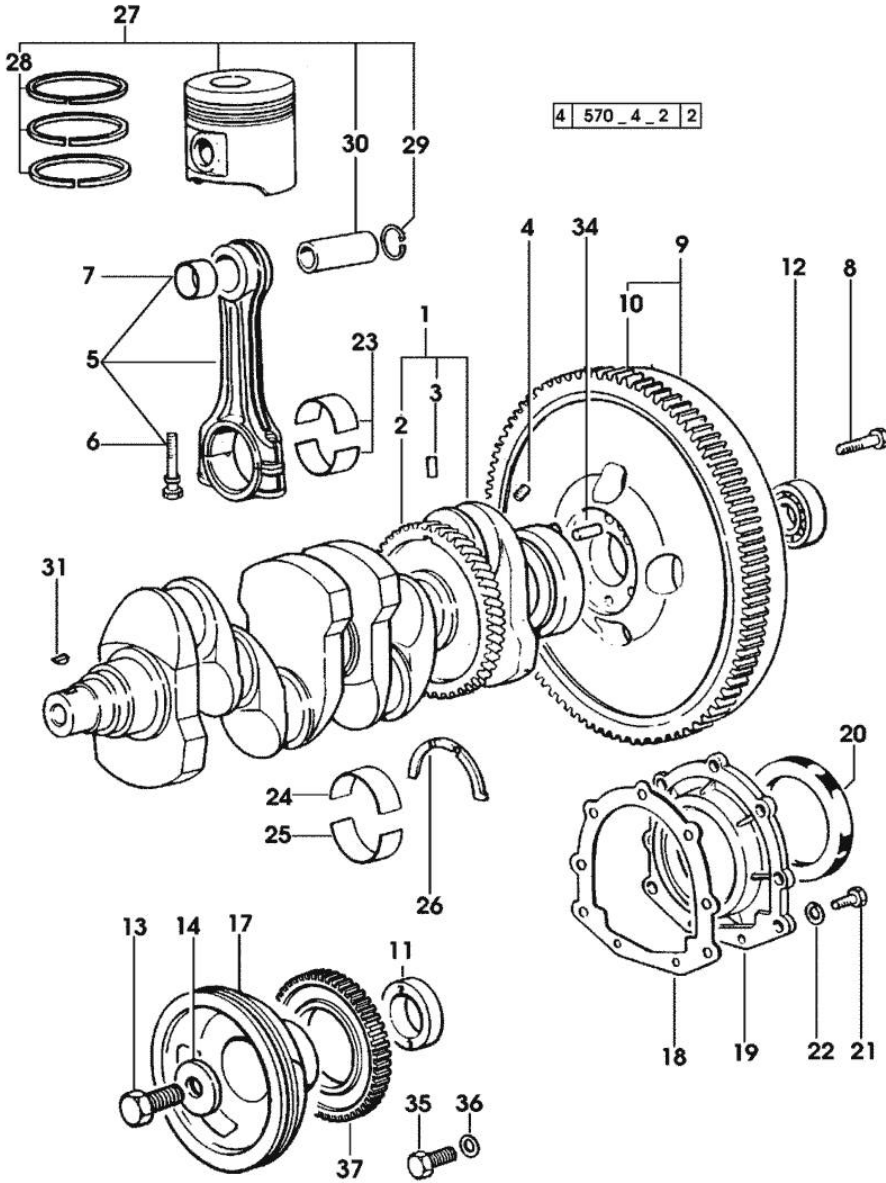

Section: ENGINE
CRANKSHAFT

Fig.	P/n	QTY	Name
27	0.087.0060.6/30	4	4230 <= X H 481 XF complete piston
27	0.379.0060.6	4	4141 <= X H 491 XF complete piston
27	0.379.0060.A	4	4230 <= X H 481 XF EXPORT U.S.A. complete piston "A" => 4231 X H 481 XF
27	0.379.0060.B	4	complete piston "B" => 4231 X H 481 XF
27	0.382.0060.6	4	complete piston
27	0.382.0060.A	4	4141 <= X H 491 XF EXPORT U.S.A. complete piston "A" => 4142 X H 491 XF
27	0.382.0060.B	4	complete piston "B" => 4142 X H 491 XF
28	0.081.0090.6/10	4	piston ring set - X H 491 XF
28	0.086.0052.6/10	4	piston ring set - X H 481 XF
29	2.1411.014.1	8	circlip 35
30	0.078.1236.0	4	piston pin Ø 18 / Ø 35 / L = mm 86
31	2.1720.006.0	1	key 4x6.5
34	2.1652.915.0	1	cylindrical plug 12x35
35	2.0112.320.2	6	screw m 10 p.1.5 x 55
36	2.1470.006.2	6	lock washer 10
37	0.011.3531.0	1	gear Z = 48

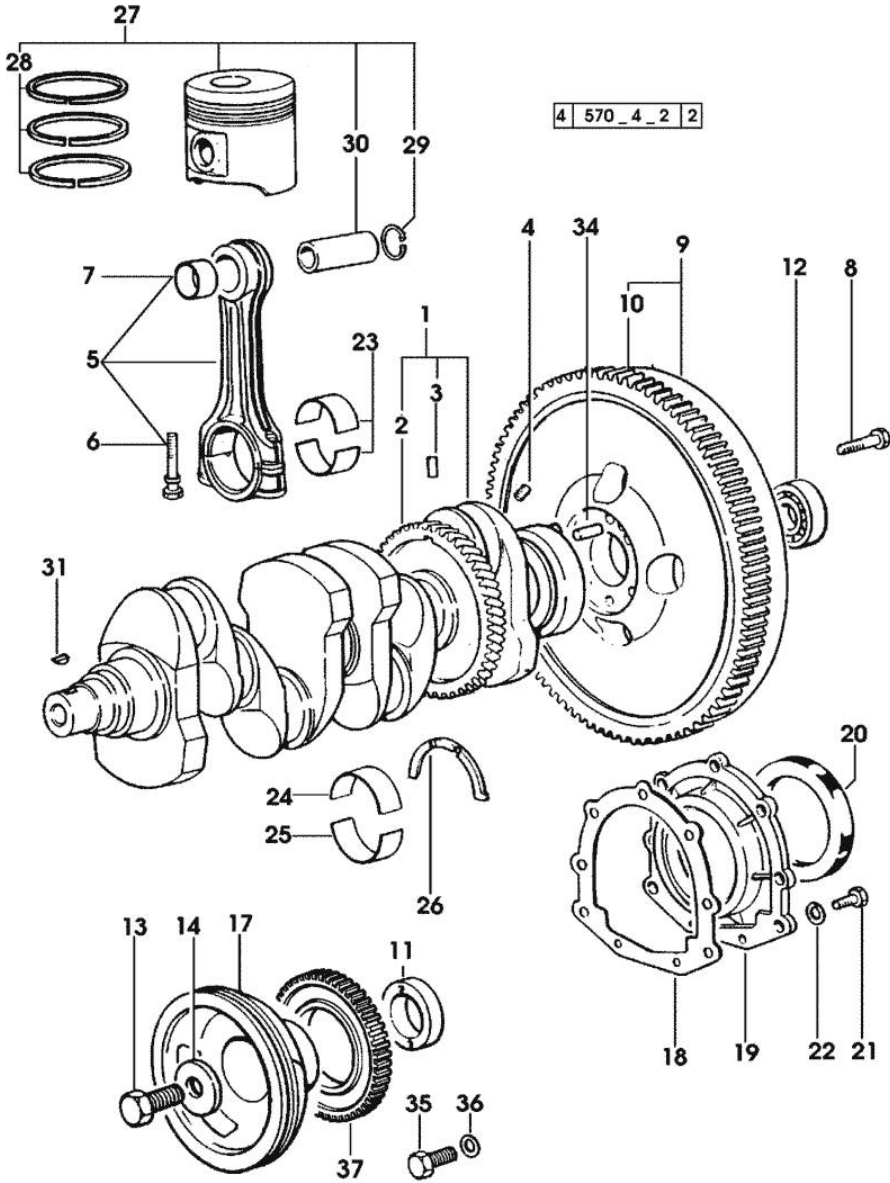

ENGINE SHAFT - FRONT P.T.O. PULLEYS

Fig.	P/n	QTY	Name
------	-----	-----	------

Notes:
[H-491-XF]

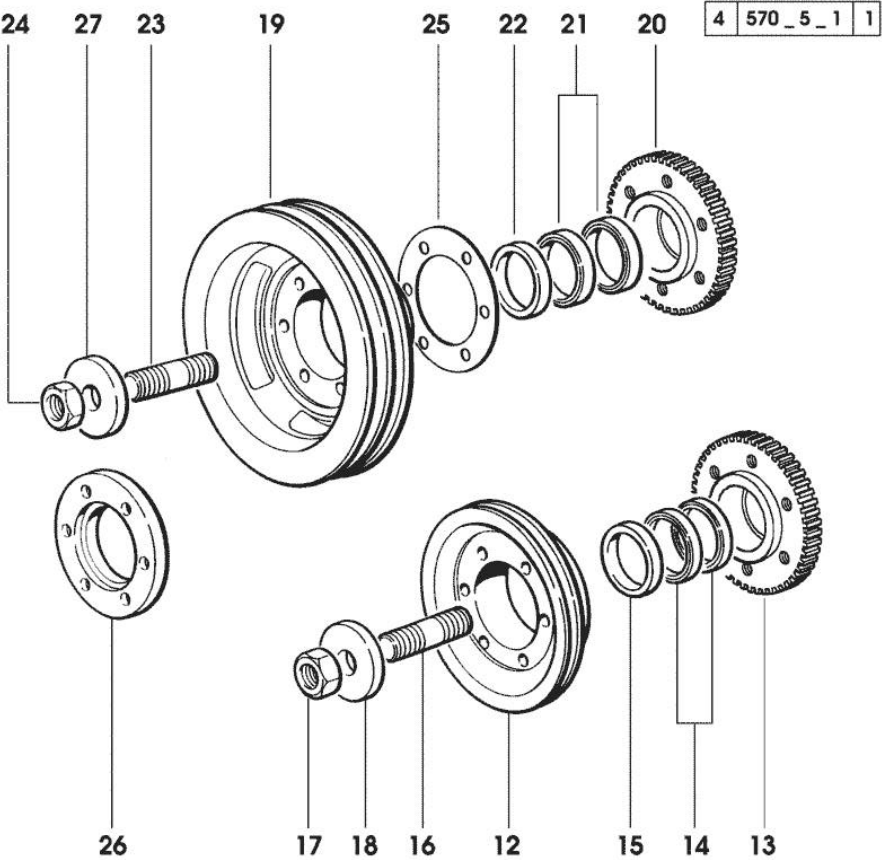

12	0.082.1244.0/10	1	pulley
13	0.011.3515.0/10	1	hub Z = 48
14	0.065.1256.0	2	ring 45x52
15	2.1579.865.0	4	spacer 45.2x51.8x10
16	2.0439.195.7	1	stud bolt m 20 p.1.5x80
17	2.1019.094.7	1	nut m 20 p.1.5
18	2.1599.524.7	1	washer 21x60x12
19	0.082.1250.0/10	1	pulley
			- FOR TRACTORS WITH AIR CONDITIONING
20	0.011.3515.0/10	1	hub Z = 48
21	0.065.1256.0	2	ring 45x52
22	2.1579.865.0	1	spacer 45.2x51.8x10
23	2.0439.195.7	1	stud bolt m 20 p.1.5x80
24	2.1019.094.7	1	nut m 20 p.1.5
25	2.1589.137.0	3	shoulder ring 71x110x1
26	0.089.1253.0/10	1	spacer
27	2.1599.524.7	1	washer 21x60x12

Section: ENGINE
COUNTERWEIGHTS

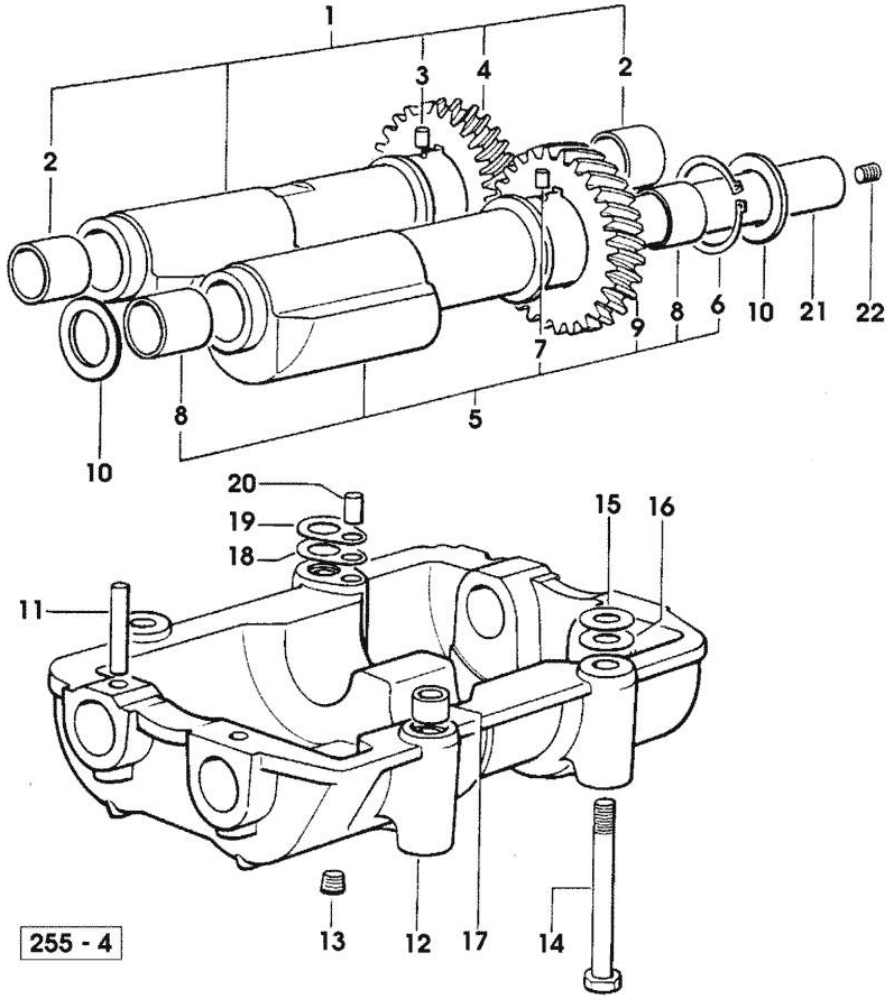

Fig.	P/n	QTY	Name
Notes:			
[H-491-XF]			
1	0.086.1233.3/30	1	mass sx/lh/li
2	2.1559.115.0	2	special bushing 26x30x30
3	2.1652.302.0	1	roll pin 4x6
4	0.000.0000.1		cannot be supplied
5	0.065.1233.3/30	1	mass dx/rh/re
6	2.1410.018.1	1	circlip 45
7	2.1652.302.0	1	roll pin 4x6
8	2.1559.115.0	2	special bushing 26x30x30
9	0.000.0000.1		cannot be supplied
10	2.1589.185.0	4	shoulder ring 26.1x34x1
11	2.1631.717.0	2	roll pin 8 x 40
12	0.086.1231.0/10	1	box
13	2.3130.001.1	4	plug 1/8" gas
14	2.0139.028.2	4	screw m 12
15	2.1579.628.0	3	spacer 16.5x26x0.1
15	2.1589.048.0		shoulder ring 16.5x26x0.3
16	2.1579.629.0	4	spacer 12.5x26x0.1
16	2.1589.049.0	2	shoulder ring 12.5x26x0.3
17	2.1579.626.0	2	spacer 13.2x16x11
18	2.1589.139.0		shoulder ring mm 0.3
19	2.1589.140.0	3	shoulder ring mm 0.1
20	2.1699.191.0	1	bush 7x10x16
21	0.065.1234.0/10	2	shaft
			* .
			- N.1 - 2.3130.001.1
22	2.3130.001.1	1	plug 1/8" gas

Section: ENGINE
CAMSHAFT

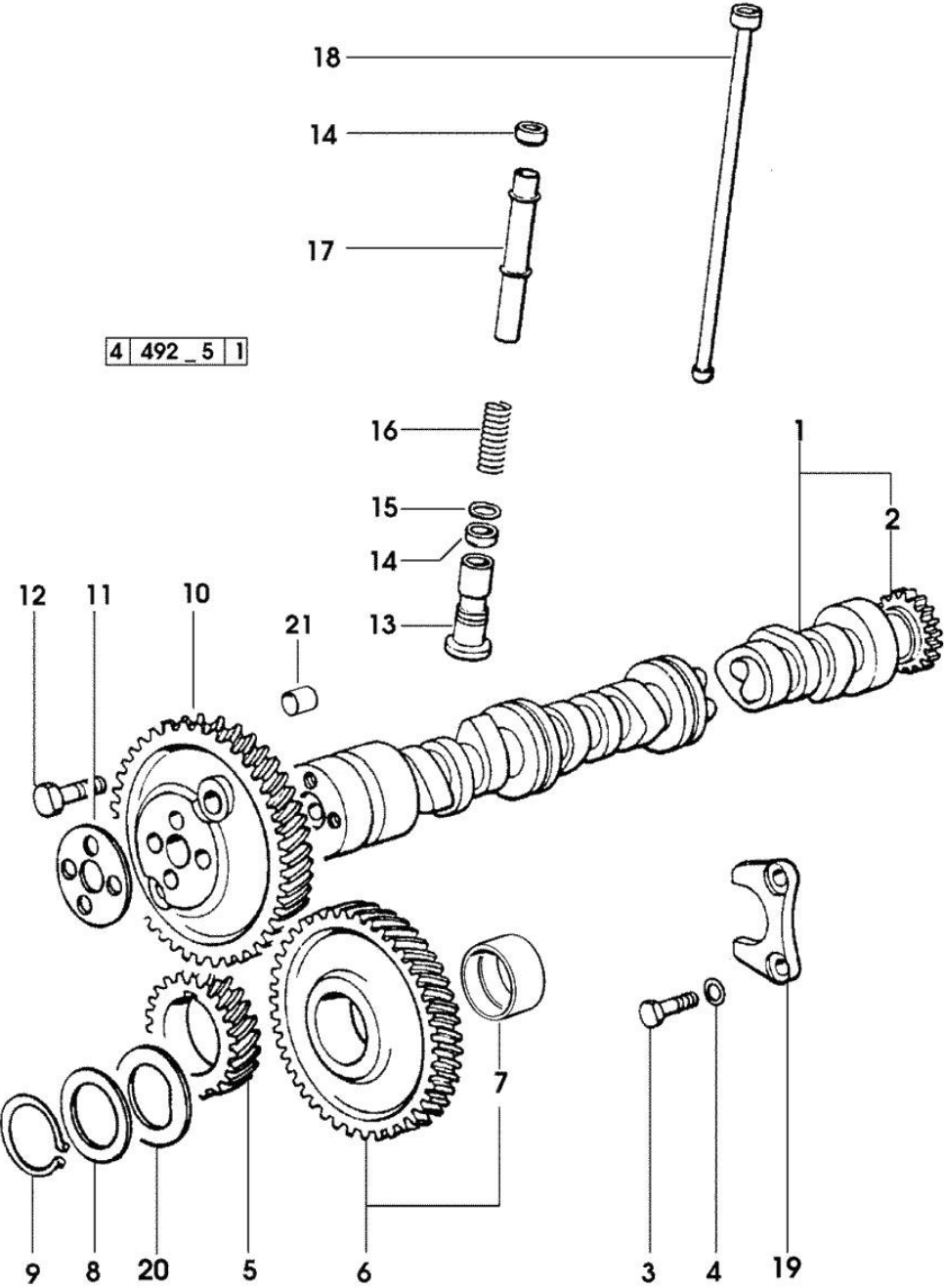

Fig.	P/n	QTY	Name
Notes:			
[H-491-XF]			
1	0.007.1712.3/10	1	camshaft 1489 <- X H 481 XF EXPORT U.S.A. 1476 <- X H 491 XF EXPORT U.S.A.
1	0.066.1310.3/40	1	camshaft
2	0.065.1324.0/10	1	gear Z = 32
3	2.0312.206.2	2	screw m 8 p 1.25 x 20
4	2.1480.014.1	2	washer 8
5	0.065.1323.0/30	1	gear Z = 29
6	0.007.1177.3/10	1	gear z = 57 - WITH RED IDENTIFICATION STAMP
6	0.007.1178.3/10	1	gear z = 57 - WITH YELLOW IDENTIFICATION STAMP
6	0.007.1179.3/10	1	gear z = 57 - WITH GREEN IDENTIFICATION STAMP
7	2.1559.185.0/10	1	bushing
8	0.065.1352.0	1	shim
9	2.1410.016.1	1	circlip 40
10	0.065.1354.0/20	1	gear z=58
11	0.065.1350.0	1	small disc
12	2.0132.207.2	4	screw m 10 p.1 x 25
13	0.065.1330.0	8	tappets
14	2.1569.114.0/10	16	gasket 14x18.5x8
15	2.1599.437.0	8	shoulder ring
16	2.4019.300.1/10	8	spring 18.5x52x2
17	0.065.1332.0	8	sleeve
18	0.065.1331.2	8	rod
19	0.065.1353.0	1	small plate
20	0.065.1351.0	2	shoulder ring
21	2.1559.398.0	1	bushing 10.5x13x12

Section: ENGINE
CYLINDER HEAD

Fig.	P/n	QTY	Name
------	-----	-----	------

Notes:
[H-491-XF]

1	2.0432.011.7	4	stud bolt m 8 p.1.25 / p.1 x 40
2	2.0432.161.7	4	stud bolt m 10 p.1.5 / p.1.25 x 40
4	0.010.6016.0	4	inlet valve mm 43.63 / Ø mm 9 - X H 481 XF
4	0.010.6017.0	4	inlet valve mm 43.63 / Ø mm 9 - X H 491 XF -> (...) = B
4	0.081.1420.0	4	inlet valve Ø mm 9 - X H 491 XF (...) <= A
5	0.010.6022.0	4	exhaust valve mm 39.1 / Ø mm 9 - X H 491 XF -> (...) = B
5	0.066.1421.0	4	exhaust valve - X H 481 XF - X H 491 XF (...) <= A
6	0.074.1423.0	16	conical valve cotter
7	0.066.1425.0	8	cup
8	2.4019.287.0	8	spring
9	0.012.2673.0	16	screw m 14 p.2x141 -> 1470 X H 481 XF -> 1458 X H 491 XF
9	0.066.1443.0/10	16	screw 1469 <= X H 481 XF 1457 <= X H 491 XF
10	0.066.1432.0	8	rocker arm
11	0.066.1430.0/10	4	support
12	2.1599.432.0	8	shoulder ring
13	2.1410.055.1	8	circlip 19
14	2.0432.163.7	8	stud bolt m 10 p.1.5 / p.1.25 x 45
15	2.1011.421.2	8	nut m 10 p.1.25
16	0.021.1434.0	8	screw
17	2.1011.405.2	8	nut m 8 p.1
18	0.007.1139.0/10	4	small cap * 1121 <= X H 481 XF * 1457 <= X H 491 XF - N.4 - 2.0399.130.2/10
19	0.065.1450.0/30	1	tappet gasket
20	2.0399.130.2	4	screw m 8 x 30 1121 <= X H 481 XF 1457 <= X H 491 XF
20	2.0399.130.2/10	4	screw m 8x36x44 => 1122 X H 481 XF => 1458 X H 491 XF

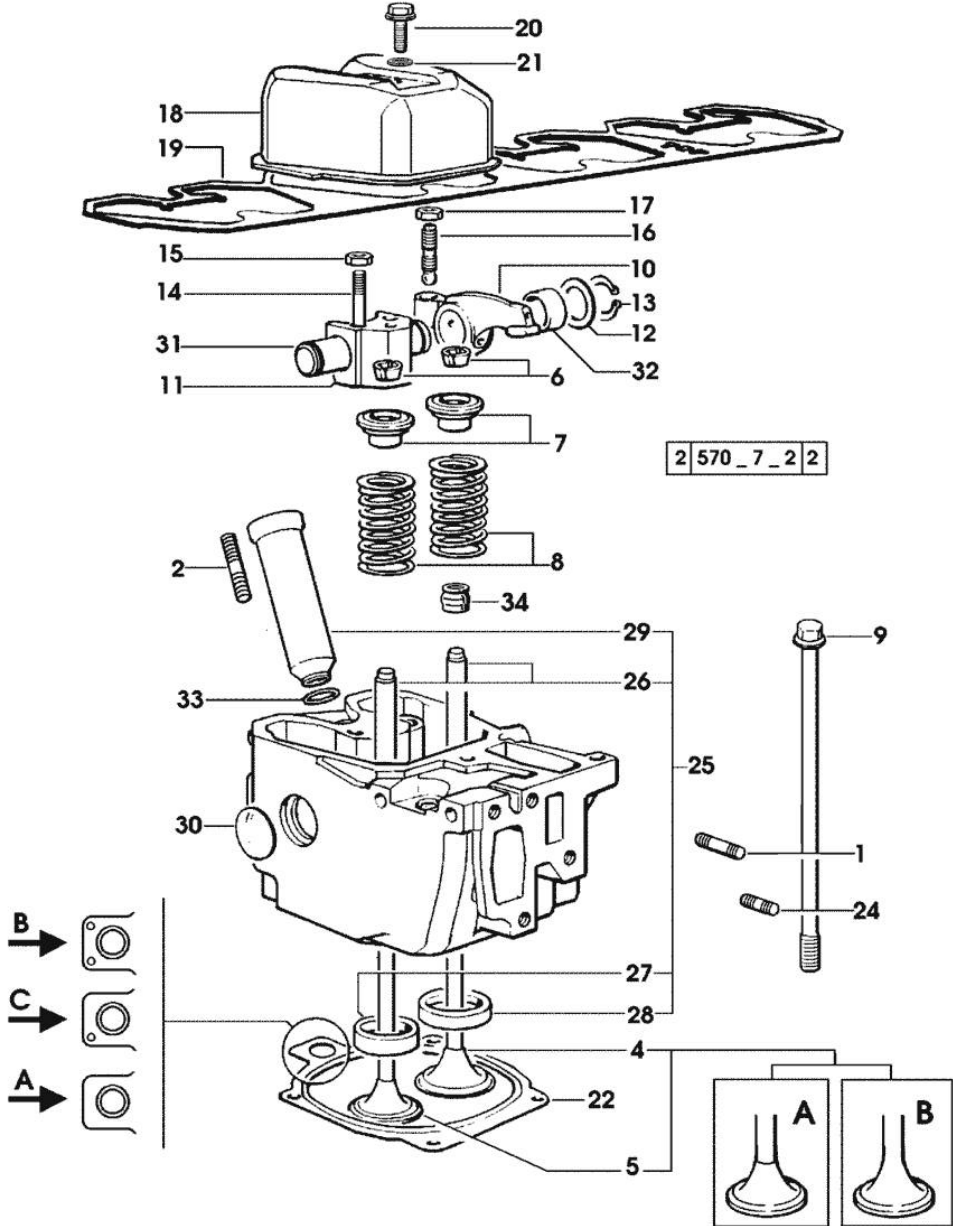

Section: ENGINE
CYLINDER HEAD

Fig.	P/n	QTY	Name
21	2.1569.170.0/10	4	gasket 8.2 x 14
22	0.078.1451.0/40	1	head gasket -A-
22	0.078.1452.0/30	1	head gasket -B-
22	0.078.1453.0/40	1	head gasket -C-
24	2.0432.005.7	4	stud bolt m 8 p.1.5 / p.1 x 25
25	0.007.1360.3/60	4	head - X H 491 XF -> (...) = B
25	0.012.2693.3/10	4	engine head - X H 481 XF - X H 491 XF (...) <- = A
26	0.007.1779.0/10	8	valve guide
27	0.066.1427.0	4	valve seat
28	0.078.1426.0	4	valve seat
29	0.010.6041.0	4	bush
30	2.3170.012.1	8	expansion plug 30
31	0.066.1431.0	4	pin
32	2.1559.021.0/40	8	bushing 15x19x22
33	2.1530.051.0	4	oil seal 20.22x3.53
34	2.1519.117.0	8	special oil seal

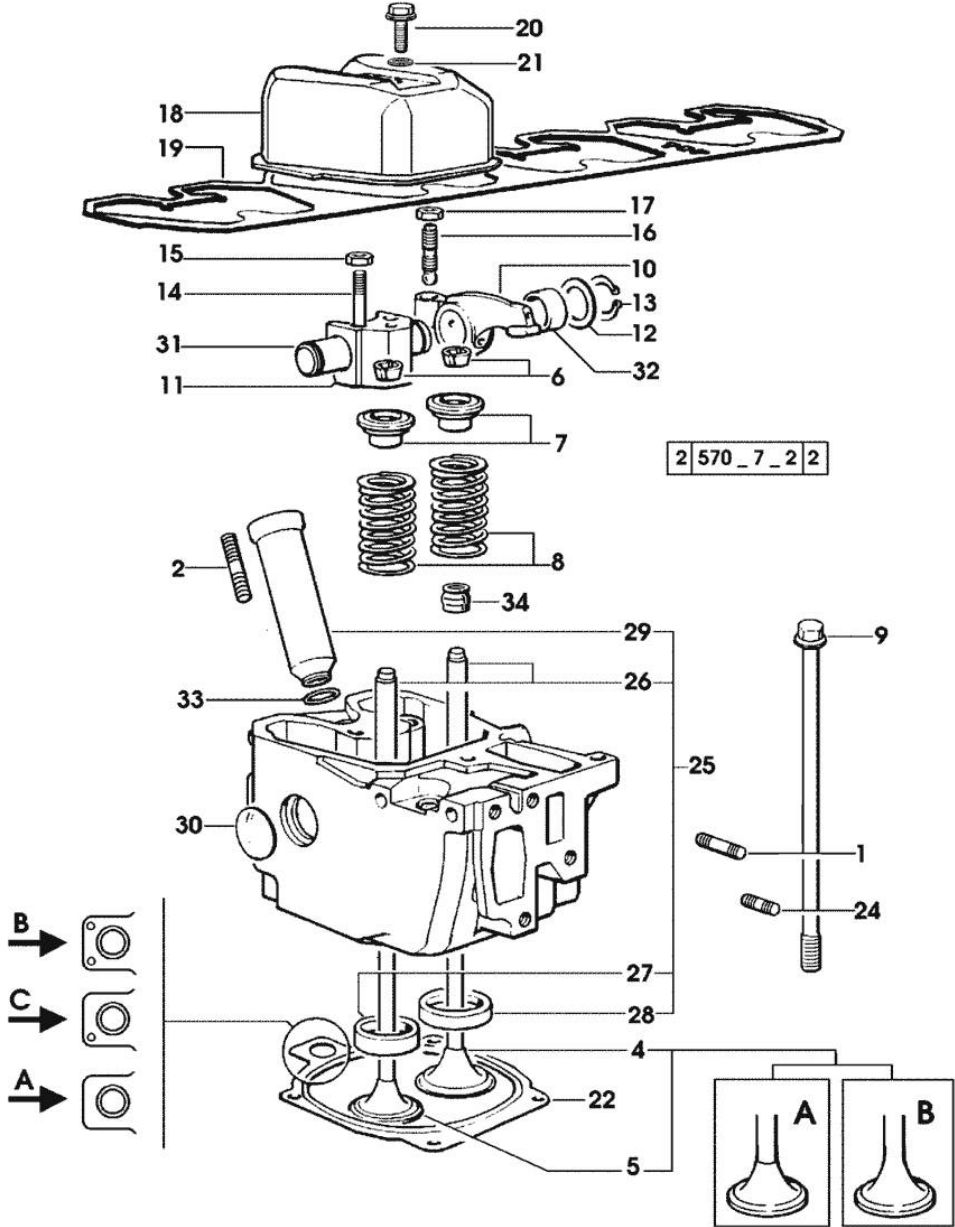

Section: ENGINE
LUBRICATION

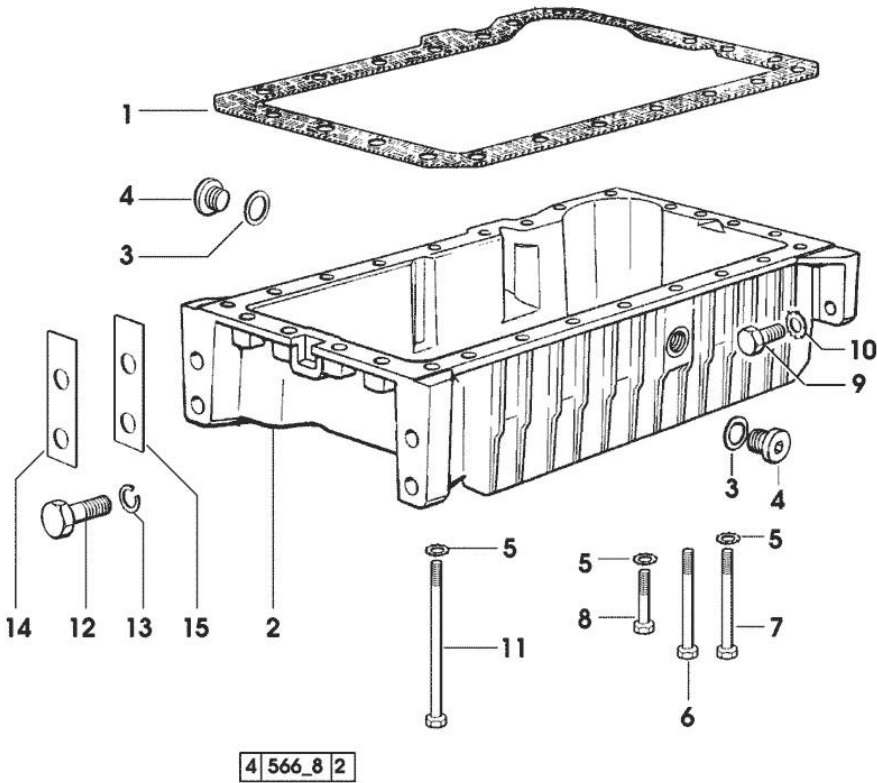

Fig.	P/n	QTY	Name
Notes:			
[H-491-XF]			
1	0.007.0614.0/10	1	gasket - X H 361 H 476 XF
1	0.065.1550.0/10	1	gasket - X H 481 H 491 XF
2	0.007.1277.0/40	1	oil sump - X H 481 H 491 XF
2	0.007.1422.0/40	1	oil sump * 13382 <= X H 361 XF * 1227 <= X H 476 XF - N.1 - 007.1427.0 - 002.8816.0
3	2.1560.054.0	1	gasket 21 x 26 - X H 361 H 476 XF
4	2.3199.001.2	1	plug 1/2" gas - X H 361 H 476 XF
5	2.1470.004.2	22	lock washer 8 - X H 361 H 476 XF
6	2.0112.226.2	7	screw m 8 p.1.25 x 85 - X H 361 H 476 XF
6	2.0112.235.2	3	screw m 8 p.1.25 x 130 - X H 481 H 491 XF
7	2.0112.226.2	4	screw m 8 p.1.25 x 85 - X H 481 H 491 XF
8	2.0112.215.2	17	screw m 8 p.1.25 x 40 - X H 361 H 476 XF
9	2.0112.411.2	4	screw m 12 p.1.75 x 30 - X H 361 H 476 XF
10	2.1470.007.2	4	lock washer 12 - X H 361 H 476 XF
11	2.0112.239.2	2	screw m 8 p.1.25 x 150
12	2.0112.720.1	4	screw m 18 p.2.5 x 55 - X H 361 H 476 XF
13	2.1475.007.7	4	washer 18 - X H 361 H 476 XF
14	0.008.8586.0/10	4	shim mm 0.20 - X H 361 H 476 XF
15	0.008.8587.0/10	8	shim mm 0.50 - X H 361 H 476 XF

Section: ENGINE
LUBRICATION

Fig.	P/n	QTY	Name
------	-----	-----	------

Notes:
[H-491-XF]

1	0.065.1531.3/20	1	tube
2	2.0112.205.2	1	screw m 8 p.1.25 x 16
			(...) <-
2	2.0112.209.2	1	screw m 8 p 1.25 x 25
			-> (...)
3	2.1470.004.2	1	lock washer 8
4	2.1579.766.2	1	spacer 8.5x16x10
5	2.3339.353.2/10	1	pipe fitting 12 p.1.5-18 p.1.5
			- X H 481 XF
6	2.1560.014.0	1	washer 18.2 x 24
			- X H 481 XF
9	0.044.1567.0	1	oil filter element
			- X H 481 XF
9	2.4419.340.0	1	oil filter element
			- X H 491 XF
10	2.1539.065.0	2	special oil seal 8.73 x 1.78
11	0.007.1623.2	1	dipstick
12	2.1011.105.2	1	nut m 8 p.1.25
13	2.1470.004.2	1	lock washer 8
14	0.065.1538.0	1	flange
15	2.1539.040.0	1	special oil seal 21.82 x 3.53
16	2.3339.307.0	1	pipe fitting m 22 p.1.5-3/4"
23	0.075.1552.4	1	bracket
24	0.075.1552.0	1	bracket
25	0.075.1552.2	1	bracket
26	2.1011.103.2	1	nut m 6 p.1
27	2.1470.002.2	1	lock washer 6
28	2.3249.014.2	1	pipe fitting m 12 p.1.5
			- X H 481 XF
29	2.1560.008.0	3	gasket 12.2 x 18
			- X H 481 XF
30	2.3335.052.2	1	pipe union m 12 p.1.5
			- X H 481 XF

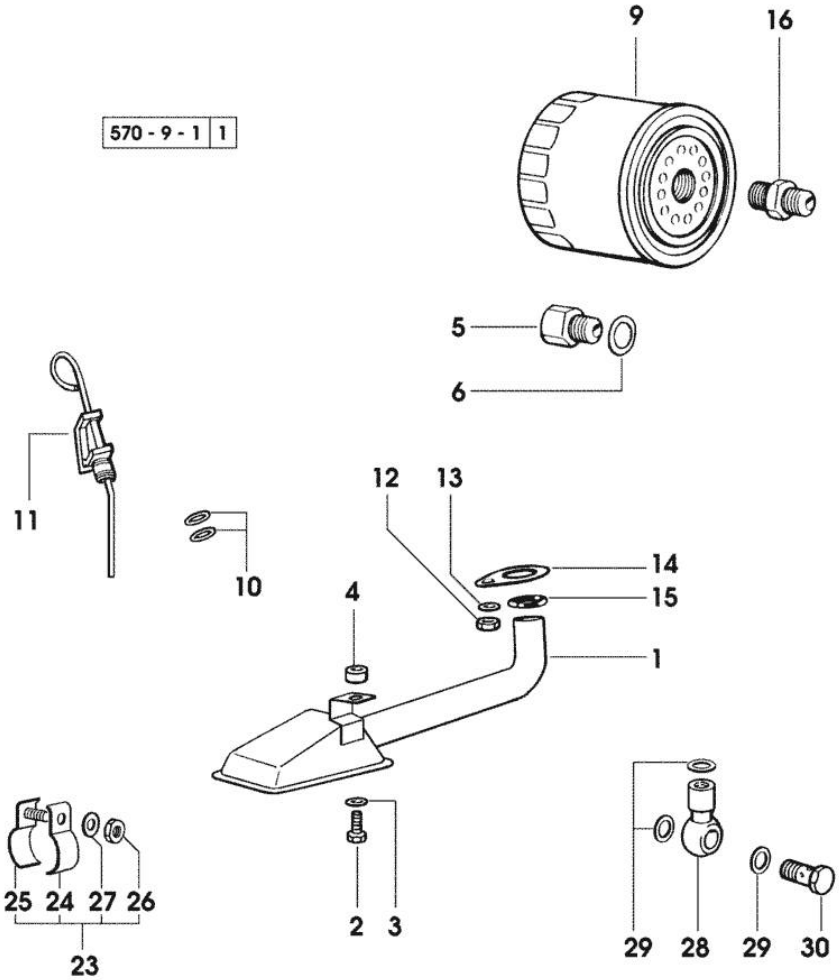

Section: ENGINE
LUBRICATION

Fig.	P/n	QTY	Name
------	-----	-----	------

Notes:
[H-491-XF]

1	0.078.1554.3	1	box
2	0.066.1750.0	1	tube
3	2.1560.014.0	1	washer 18.2 x 24
4	2.3120.101.0	1	plug m 18 p.1.5
5	0.078.1557.0/10	2	gasket
6	0.078.1556.0/10	1	gasket
7	0.078.1555.0/10	1	plate
8	2.1310.004.2	8	flat washer 8.4x17
9	2.0112.205.2	8	screw m 8 p.1.25 x 16
10	2.1480.014.1	4	washer 8
11	2.0312.217.2	2	screw m 8 p.1.25x55
12	2.0312.220.2	2	screw m 8 p.1.25x70
13	2.1539.048.0	1	special oil seal 20.35x1.78
14	2.1539.050.0	1	special oil seal 69.57x1.78
15	0.078.1540.3	1	radiator

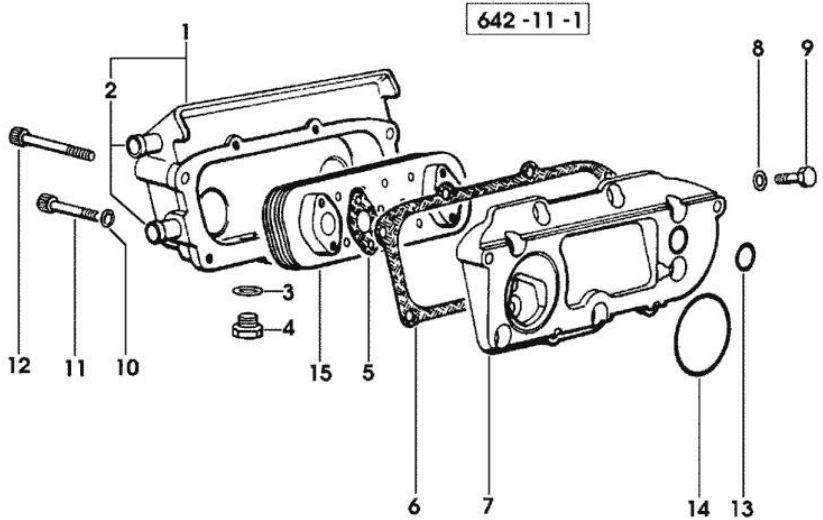

Section: ENGINE
LUBRICATION

Fig.	P/n	QTY	Name
------	-----	-----	------

Notes:
[H-491-XF]

1	2.0312.206.2	2	screw m 8 p 1.25 x 20
2	2.1480.014.1	2	washer 8
3	0.041.1135.4	1	plug 1" gas
4	2.1569.072.0	1	gasket 32 x 39.5 x 2
5	0.065.1565.0/10	1	pipe union
6	0.010.5441.4/10	1	oil pump - X H 481 H 491 XF
6	0.010.5481.4	1	oil pump - X H 361 H 476 XF
7	0.065.1552.3/60	1	valve
8	2.1539.042.0	1	special oil seal 47.35x1.78
9	2.1651.711.0	2	pin 8 x 14
10	2.0169.005.2	2	screw m 6 p.1 x 12
11	0.065.1569.0/40	1	shaft
12	2.1470.006.2	2	lock washer 10
13	2.0112.323.2	2	screw m 10 p.1.5x70 - X H 361 H 476 XF
13	2.0112.325.2	2	screw m 10 p.1.5 x 80 - X H 481 H 491 XF
14	0.065.1560.0/20	2	gasket
15	0.065.1562.0/10	1	joint
16	0.075.1551.4/20	1	support
17	2.2020.001.0	1	ball bearing 15 x 32 x 8.00
18	2.2725.016.0	1	roller cage 15 x 21 x 12
19	2.2680.020.0	1	ring 12 x 15 x 12
20	2.0399.128.2/10	1	screw m 8 p.1 x 8
21	2.2030.002.0	1	ball bearing 12 x 28 x 8
22	2.1219.025.2/10	1	ring nut m 36 p.1.5
23	2.1589.148.0	1	shoulder ring 28.2 x 31.8 x 0.5
23	2.1589.150.0	2	shoulder ring 28.2 x 31.8 x 0.1
23	2.1589.151.0	2	shoulder ring 28.2 x 31.8 x 0.15
24	0.075.1551.3/30	1	support
25	2.1589.146.0	2	shoulder ring 15.2 x 19 x 0.15
25	2.1589.147.0	2	shoulder ring 15.2 x 19 x 0.10
25	2.1589.153.0	1	shoulder ring 15.2 x 19 x 1.00
26	2.1410.057.1	1	circlip 15
27	2.0342.007.2	1	screw m 4 p.0.7x25
28	0.065.1558.6/10	1	bevel drive
29	0.065.1559.0	1	bush
30	2.1560.010.0	1	gasket 14.2 x 20
31	2.3110.403.1	1	plug m 14 p.1.5x12

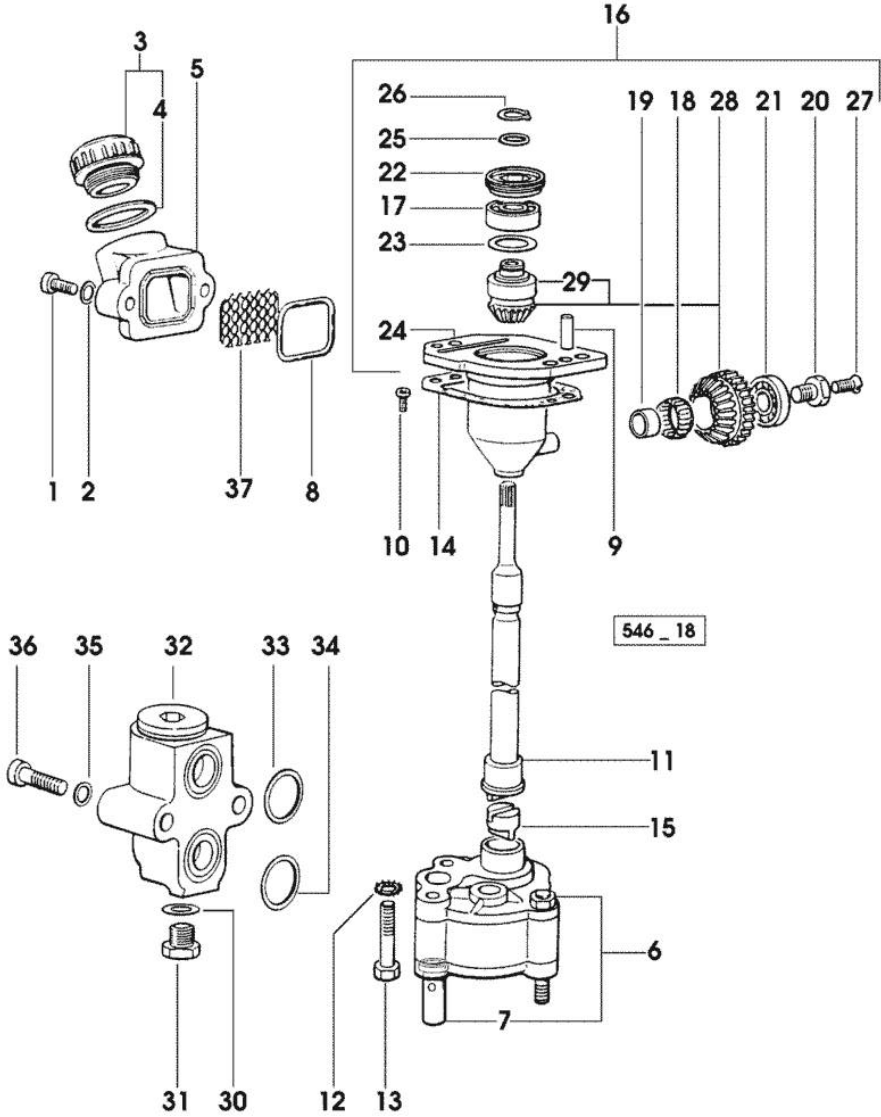

Thank you so much for reading.
Please click the “Buy Now!”
button below to download the
complete manual.



After you pay.

You can download the most
perfect and complete manual in
the world immediately.

Our support email:

ebooklibonline@outlook.com