

CONDENSER SUPPORT

Fig.	P/n	QTY	Name
------	-----	-----	------

Notes:

[IRON 110 -> ZKDL290200TS10001] 10002 <-

27	0.014.2848.3/40	1	chassis frame
28	2.1559.147.0	4	bushing
29	0.014.4027.0	2	pin
30	2.1430.009.2	2	ring 8
31	2.0129.065.0	5	screw m 6 x 14
32	2.1012.103.7	4	nut m 6 p.1
33	2.1312.003.2	6	washer 6
37	0.014.4410.3/10	1	bracket dx/rh/re
38	0.014.4411.3/10	1	bracket sx/lh/li
39	2.1011.505.2	4	nut m 8 p.1
42	0.014.4770.0/10	2	knob
43	2.0312.214.2	2	screw m 8 p.1.25 x 40
44	0.014.4769.0/10	2	bushing
45	2.4019.797.2	2	spring

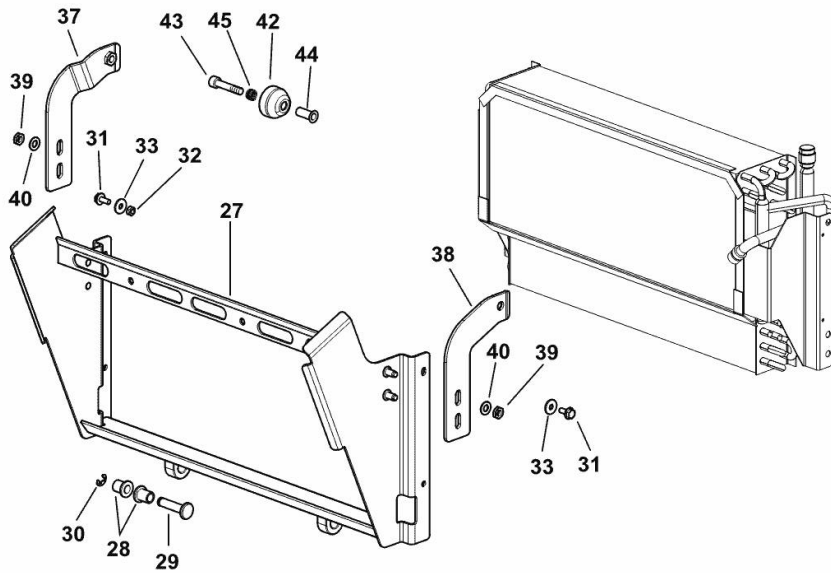

9_L3886_22_0-D-001

CONDENSER SUPPORT

Fig.	P/n	QTY	Name
------	-----	-----	------

Notes:

[IRON 110 -> ZKDL290200TS10001] -> 10003

27	0.015.0841.3/10	1	chassis frame
28	2.1559.147.0	4	bushing
29	0.014.4027.0	2	pin
30	2.1430.009.2	2	ring 8
31	2.0112.005.2	6	screw m 6 p.1 x 16 (-> 10074)
33	2.1312.003.2	8	washer 6 (-> 10074)
42	0.014.4770.0/10	2	knob
43	2.0312.214.2	2	screw m 8 p.1.25 x 40
44	0.014.4769.0/10	2	bushing
45	2.4019.797.2	2	spring
52	2.6999.064.6	3	special nut m 6
53	2.1310.004.2	2	flat washer 8.4x17
54	2.1120.005.2	2	nut m 8 p.1.25

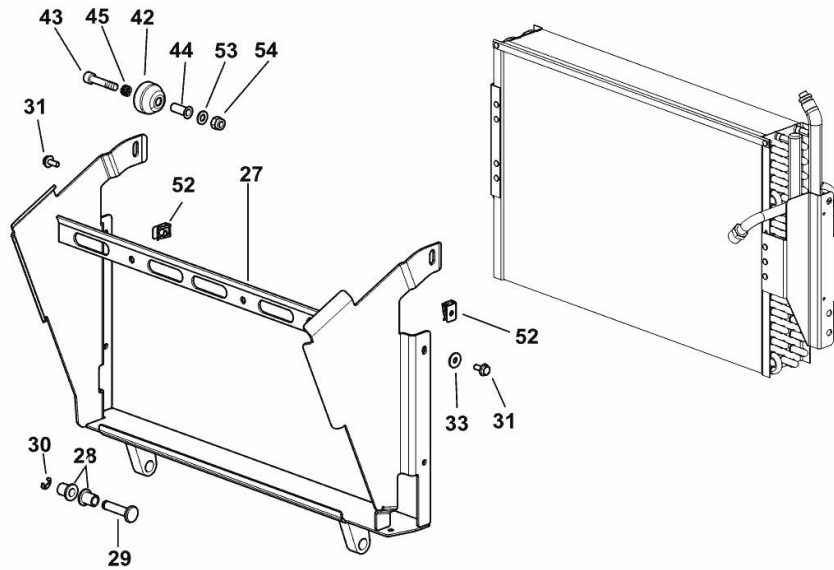

9_L3886_22_0-D-002

HOOD - SUPPORTS

Fig.	P/n	QTY	Name
------	-----	-----	------

Notes:

[IRON 110 -> ZKDL290200TS10001] 10013 <-

1	0.014.2935.3/70	1	support
2	0.014.1724.3/50	1	support
3	0.014.3319.0/10	1	cover
6	0.013.1311.4	2	shock absorber
7	06547602	2	bellows
8	04452747	2	spacer
9	2.1310.006.2	7	flat washer 10.5x21
10	2.0112.311.2	3	screw m 10 p.1.5 x 30
11	0.014.3328.0/20	1	shield
13	2.0112.309.2	4	screw m 10 p.1.5 x 25
14	2.0113.319.2	4	screw m 10 p.1.5 x 50
15	2.1475.103.2	4	washer 10.5
16	2.0112.207.2	1	screw m 8 p 1.25 x 20
17	2.0112.223.2	1	screw m 8 p.1.25x70
18	2.1310.004.2	2	flat washer 8.4x17
21	04450691	2	cap
22	2.1011.105.2	1	-
23	04454185/10	1	support
25	2.6839.066.0/10	1	clamp 16
27	2.0114.005.2	9	screw m 6 p.1.0 x 16
28	2.1599.545.2	8	washer 6.5x28x2
32	0.014.1241.0/10	1	rope mm 950

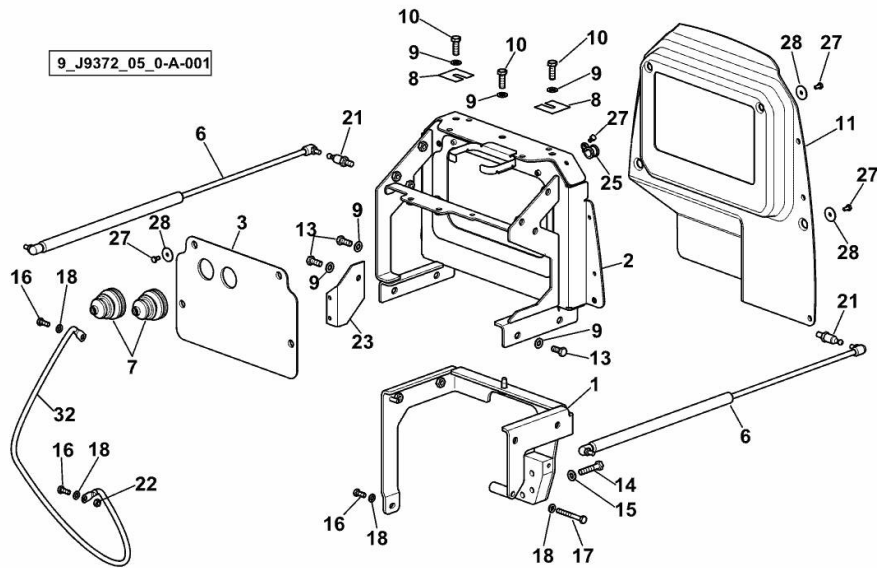

HOOD MOUNTS PACKAGE

Fig.	P/n	QTY	Name
------	-----	-----	------

Notes:

[IRON 110 -> ZKDL290200TS10001] -> 10014

1	0.015.7974.0	1	bracket
6	0.013.1311.4	2	shock absorber
9	2.1310.006.2	2	flat washer 10.5x21
13	2.0112.309.2	2	screw m 10 p.1.5 x 25
16	04453906	1	screw m 8 x 20
18	2.1310.004.2	1	flat washer 8.4x17

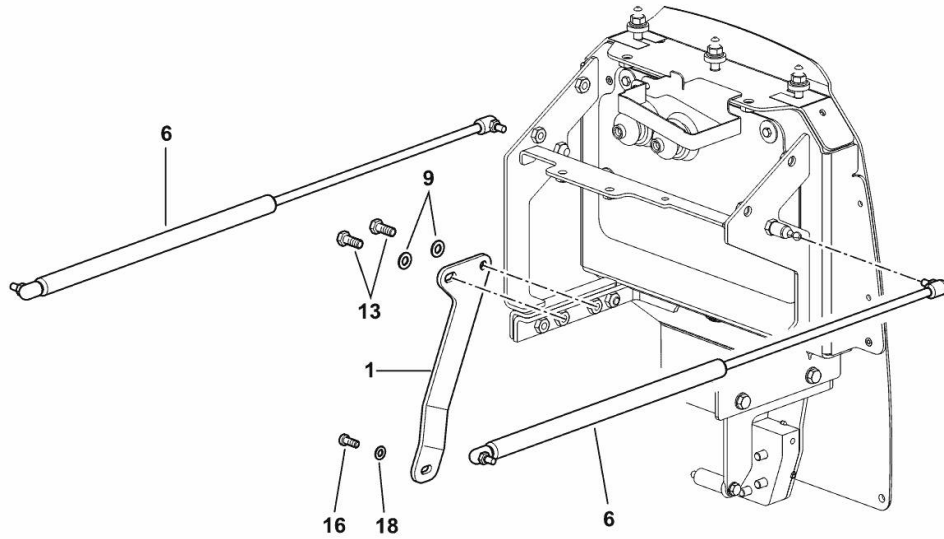

9_L5272_05_0-A-001

HOOD - SUPPORTS

Fig.	P/n	QTY	Name
------	-----	-----	------

Notes:

[IRON 110 -> ZKDL290200TS10001] -> 10014 - 10024 <-

1	0.015.7109.3/10	1	battery support
2	0.015.7998.3/10	1	division
3	0.014.3319.0/10	1	cover
7	06547602	2	bellows
8	04452747	2	spacer
9	2.1310.006.2	6	flat washer 10.5x21
10	2.0112.311.2	3	screw m 10 p.1.5 x 30
11	0.014.3328.0/20	1	shield
13	2.0112.309.2	3	screw m 10 p.1.5 x 25
14	2.0113.319.2	4	screw m 10 p.1.5 x 50
15	2.1475.103.2	4	washer 10.5
16	2.0112.207.2	2	screw m 8 p 1.25 x 20
17	2.0112.223.2	1	screw m 8 p.1.25x70
18	2.1310.004.2	3	flat washer 8.4x17
21	04450691	2	cap
22	2.1011.105.2	1	nut m 8 p.1.25
27	2.0112.003.2	8	screw m 6 p.1 x 12
28	2.1599.545.2	8	washer 6.5x28x2
32	0.014.1241.0/10	1	rope mm 950

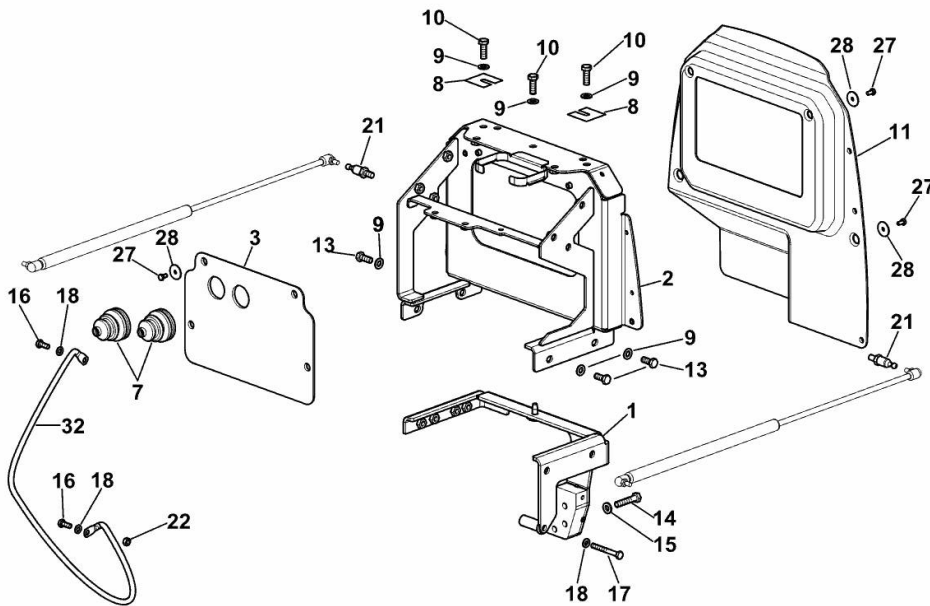

9_L3872_05_0-A-001

HOOD - SUPPORTS

Fig.	P/n	QTY	Name
------	-----	-----	------

Notes:

[IRON 110 -> ZKDL290200TS10001] -> 10025 - 10074 <-

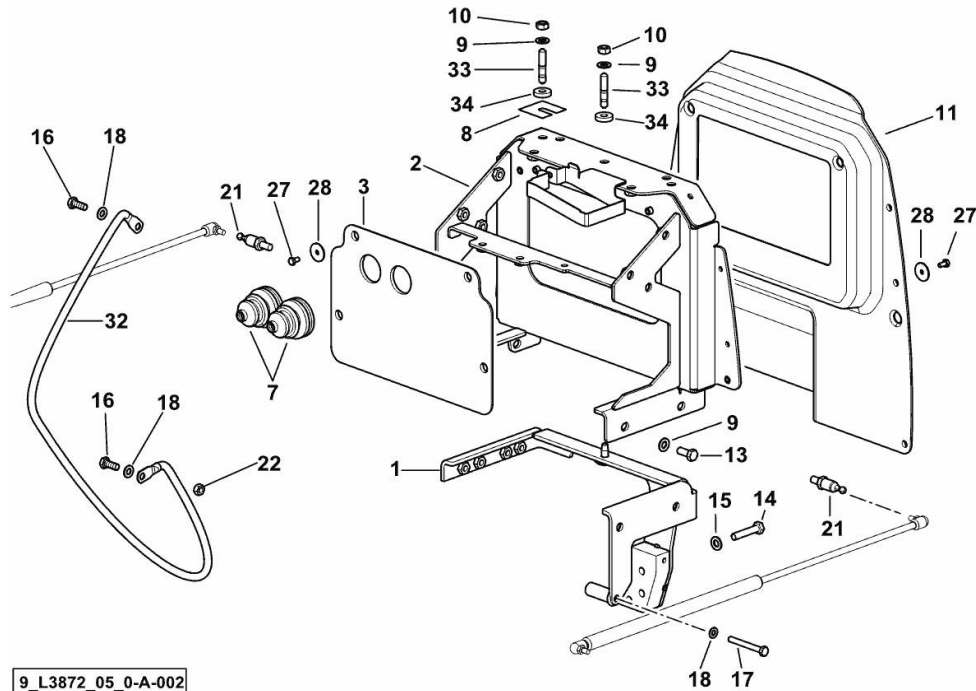

1	0.015.7109.3/10	1	battery support
2	0.015.7998.3/10	1	division
3	0.014.3319.0/10	1	cover
7	06547602	2	bellows
8	04452747	2	spacer
9	2.1310.006.2	6	flat washer 10.5x21
10	2.1011.106.2	3	nut m 10 p.1.5
11	0.014.3328.0/20	1	shield
13	2.0112.309.2	3	screw m 10 p.1.5 x 25
14	2.0113.319.2	4	screw m 10 p.1.5 x 50
15	2.1475.103.2	4	washer 10.5
16	2.0112.207.2	2	screw m 8 p 1.25 x 20
17	2.0112.223.2	1	screw m 8 p.1.25x70
18	2.1310.004.2	3	flat washer 8.4x17
21	04450691	2	cap
22	2.1011.105.2	1	nut m 8 p.1.25
27	2.0112.003.2	8	screw m 6 p.1 x 12
28	2.1599.545.2	8	washer 6.5x28x2
32	0.014.1241.0/10	1	rope mm 950
33	2.0422.311.2	3	stud bolt m 10 x 40
34	2.1549.647.2	3	spacer 10.1x26x6

9_L3872_05_0-A-002

HOOD - SUPPORTS

Fig.	P/n	QTY	Name
------	-----	-----	------

Notes:

[IRON 110 -> ZKDL290200TS10001] -> 10075 - 10082 <-

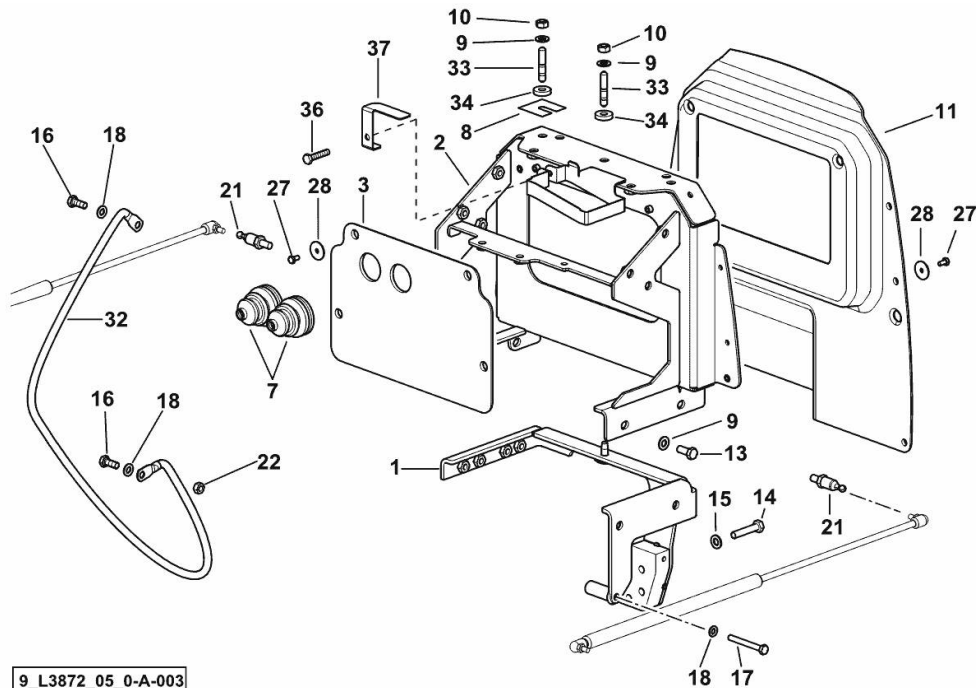

1	0.015.7109.3/10	1	battery support
2	0.015.7998.3/20	1	division
3	0.014.3319.0/10	1	cover
7	06547602	2	bellows
8	04452747	2	spacer
9	2.1310.006.2	6	flat washer 10.5x21
10	2.1011.106.2	3	nut m 10 p.1.5
11	0.014.3328.0/20	1	shield
13	2.0112.309.2	3	screw m 10 p.1.5 x 25
14	2.0113.319.2	4	screw m 10 p.1.5 x 50
15	2.1475.103.2	4	washer 10.5
16	2.0112.207.2	2	screw m 8 p 1.25 x 20
17	2.0112.223.2	1	screw m 8 p.1.25x70
18	2.1310.004.2	3	flat washer 8.4x17
21	04450691	2	cap
22	2.1011.105.2	1	nut m 8 p.1.25
27	2.0112.003.2	8	screw m 6 p.1 x 12
28	2.1599.545.2	8	washer 6.5x28x2
32	0.014.1241.0/10	1	rope mm 950
33	2.0422.311.2	3	stud bolt m 10 x 40
34	2.1549.647.2	3	spacer 10.1x26x6
36	2.0112.011.2	1	screw m 6 p.1x30
37	0.018.2137.0	1	bracket

9_L3872_05_0-A-003

HOOD - SUPPORTS

Fig.	P/n	QTY	Name
------	-----	-----	------

Notes:

[IRON 110 -> ZKDL290200TS10001] -> 10084

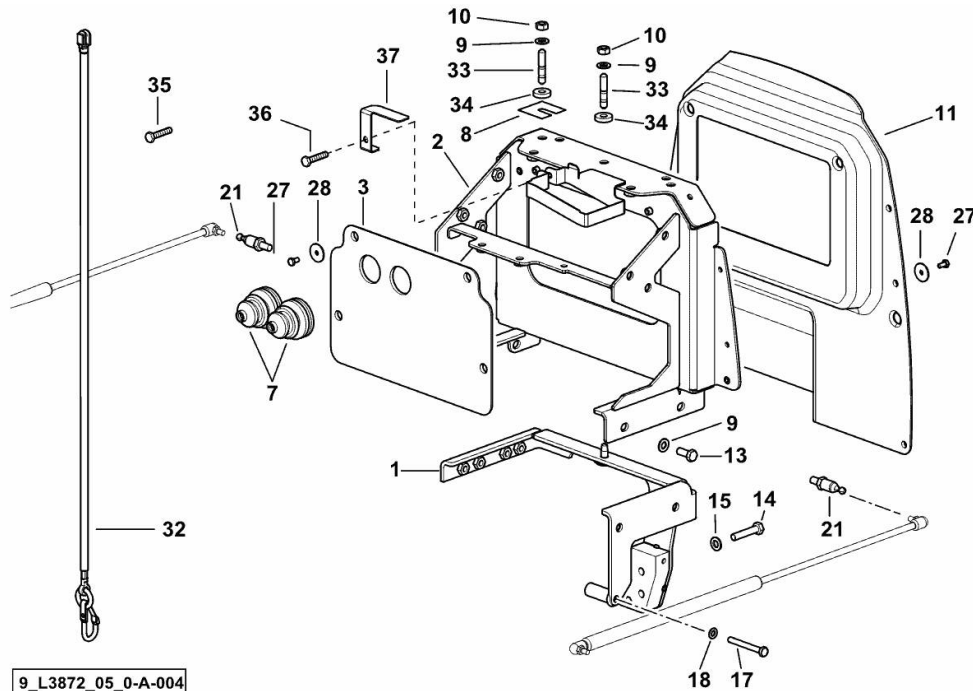

1	0.015.7109.3/10	1	battery support
2	0.015.7998.3/20	1	division
3	0.014.3319.0/10	1	cover
7	06547602	2	bellows
8	04452747	2	spacer
9	2.1310.006.2	6	flat washer 10.5x21
10	2.1011.106.2	3	nut m 10 p.1.5
11	0.014.3328.0/20	1	shield
13	2.0112.309.2	3	screw m 10 p.1.5 x 25
14	2.0113.319.2	4	screw m 10 p.1.5 x 50
15	2.1475.103.2	4	washer 10.5
17	2.0112.223.2	1	screw m 8 p.1.25x70
18	2.1310.004.2	1	flat washer 8.4x17
21	04450691	2	cap
27	2.0112.003.2	8	screw m 6 p.1 x 12
28	2.1599.545.2	8	washer 6.5x28x2
32	0.017.1219.4	1	cord
33	2.0422.311.2	3	stud bolt m 10 x 40
34	2.1549.647.2	3	spacer 10.1x26x6
35	2.0112.009.2	1	screw m 6 p.1 x 25
36	2.0112.011.2	1	screw m 6 p.1x30
37	0.018.2137.0	1	bracket

9_L3872_05_0-A-004

HOOD TO CAB CONNECTION FRAME

Fig.	P/n	QTY	Name
------	-----	-----	------

Notes:

- FOR TYPES WITH FIXED CAB [IRON 110 -> ZKDL290200TS10001] 10004 <-

1	0.014.3037.0/30	1	frame (10004 <-)
1	0.016.3787.0/10	1	frame
2	0.014.3565.2	1	plate

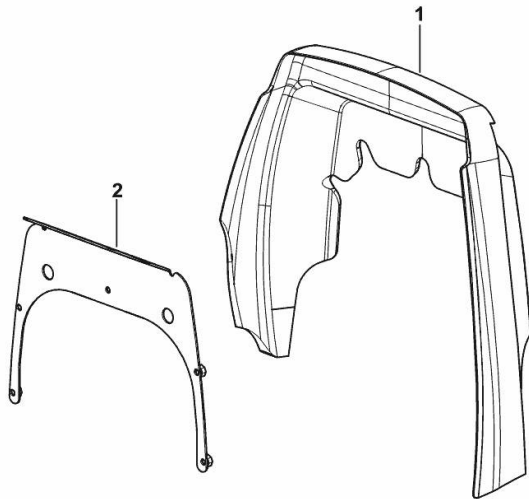

9_B1572_11_0-A-001

HOOD TO CAB CONNECTION FRAME

Fig.	P/n	QTY	Name
------	-----	-----	------

Notes:

- FOR TYPES WITH FIXED CAB [IRON 110 -> ZKDL290200TS10001] -> 10008

1	0.016.3787.0/10	1	frame
2	0.014.3565.2	1	plate

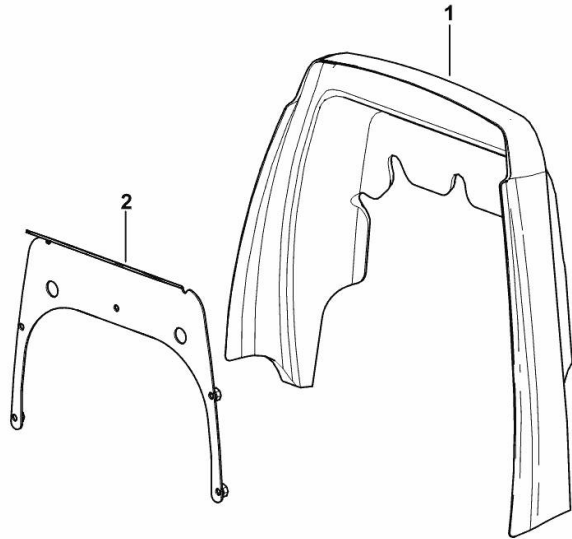

9_L3972_11_0-A-001

HOOD TO CAB CONNECTION FRAME

Fig.	P/n	QTY	Name
------	-----	-----	------

Notes:

- FOR TYPES WITH SUSPENDED CAB [IRON 110 -> ZKDL290200TS10001] 10003 <-

1	0.014.3036.0/40	1	frame (10003 <-)
1	0.016.3789.0/10	1	frame
2	0.014.3565.2	1	plate

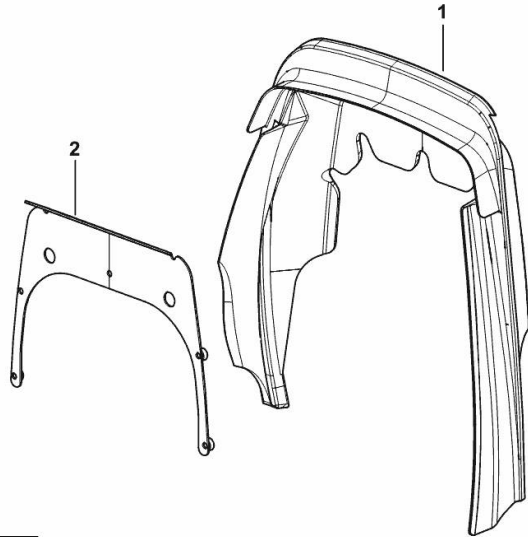

9_B1572_13_0-A-001

HOOD TO CAB CONNECTION FRAME

Fig.	P/n	QTY	Name
------	-----	-----	------

Notes:

- FOR TYPES WITH SUSPENDEED CAB [IRON 110 -> ZKDL290200TS10001] - FOR TYPES WITH SUSPENDEED CAB [IRON 110 -> ZKDL290200TS10001] -> 10005 - FOR TYPES WITH SUSPENDEED CAB [IRON 110 -> ZKDL290200TS10001] -> 10006

1	0.016.3789.0/10	1	frame
2	0.014.3565.2	1	plate

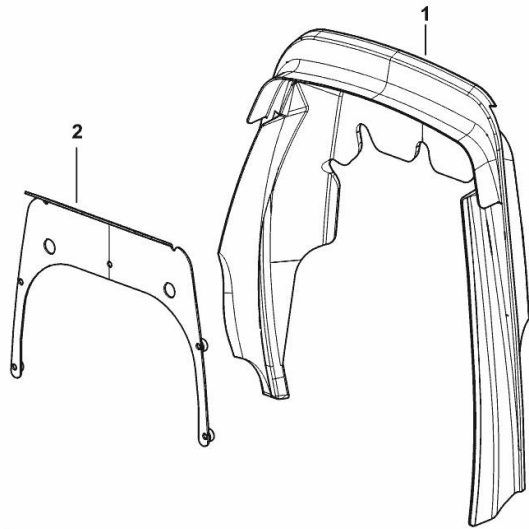

9_L3972_13_0-A-001

PEDAL SUPPORT

Fig.	P/n	QTY	Name
------	-----	-----	------

Notes:

[IRON 110 -> ZKDL290200TS10001]

1	0.016.7556.3	1	support
2	2.0365.305.3	8	screw
3	2.1310.004.2	2	flat washer 8.4x17
4	2.1011.105.2	2	nut m 8 p.1.25
5	4.970.56.075	1.5	

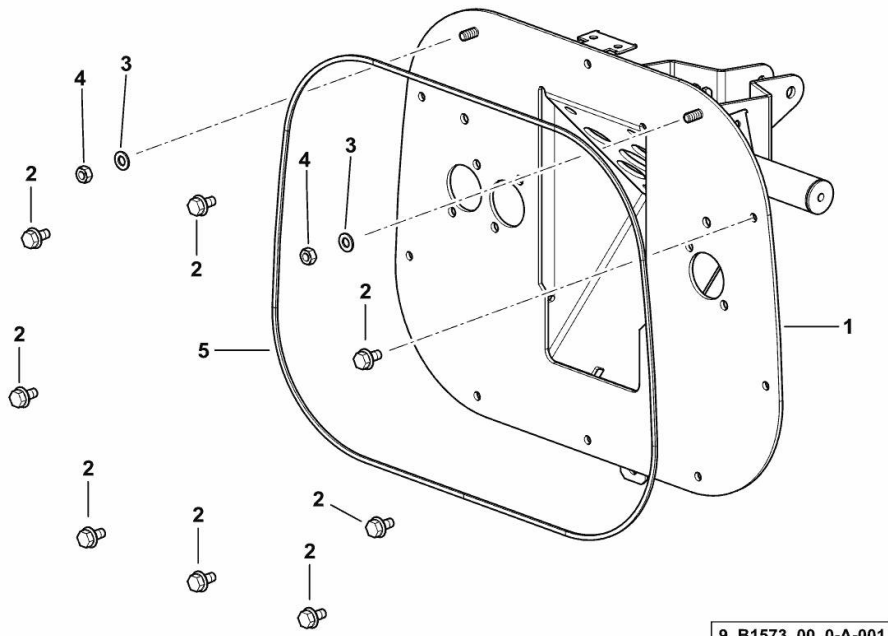

9_B1573_00_0-A-001

BATTERY SUPPORT

Fig.	P/n	QTY	Name
------	-----	-----	------

Notes:

[IRON 110 -> ZKDL290200TS10001] 10066 <-

1	0.014.9380.4/20	1	battery support
2	0.014.9386.4/10	1	cover
3	0.008.3436.0/10	1	crosspiece
4	0.009.1354.0/10	1	gasket mm 360
5	2.0112.207.2	4	screw m 8 p 1.25 x 20
6	2.1470.004.2	4	lock washer 8
7	2.1310.004.2	4	flat washer 8.4x17

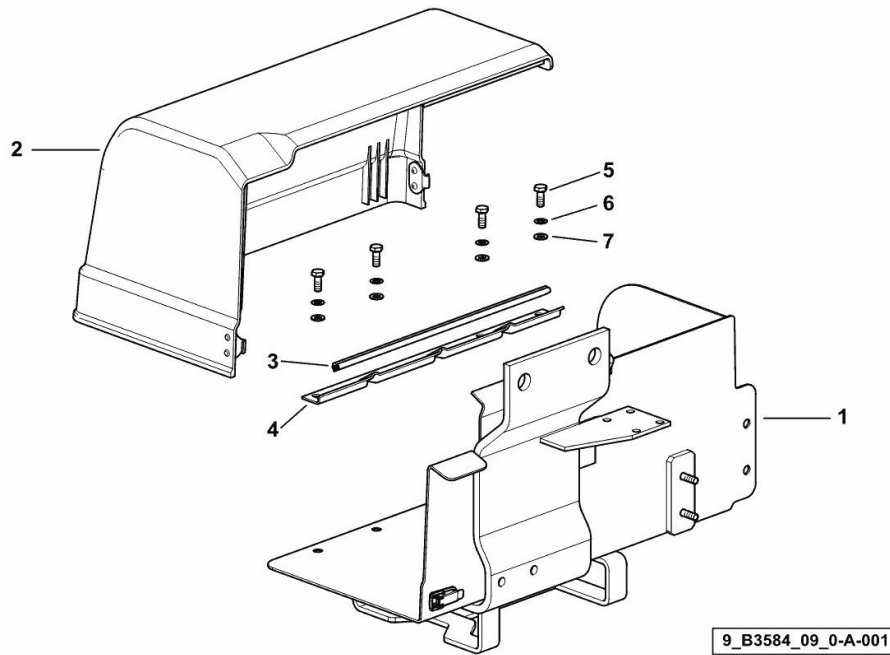

BATTERY SUPPORT

Fig.	P/n	QTY	Name
------	-----	-----	------

Notes:

[IRON 110 -> ZKDL290200TS10001] [IRON 110 -> ZKDL290200TS10001] -> 10067

1	0.017.0576.4	1	battery support
1.9	0.014.7214.0	3	closure
1.11	2.1899.090.0	6	rivet 3x8
2	0.014.9386.4/10	1	cover
3	0.008.3436.0/10	1	crosspiece
4	0.009.1354.0/10	1	gasket mm 360
5	2.0112.207.2	4	screw m 8 p 1.25 x 20
6	2.1470.004.2	4	lock washer 8
7	2.1310.004.2	4	flat washer 8.4x17

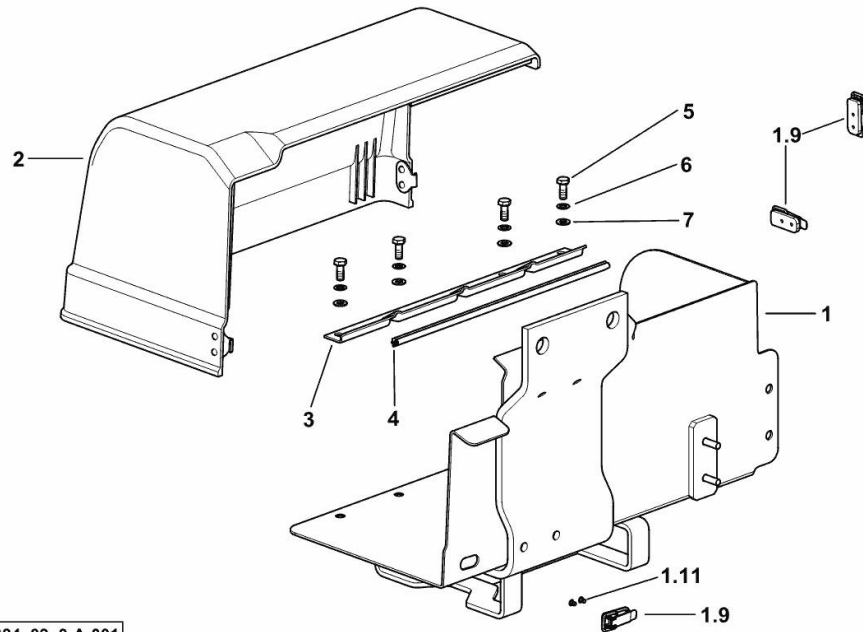

9_L3884_09_0-A-001

Thank you so much for reading.
Please click the “Buy Now!”
button below to download the
complete manual.



After you pay.

You can download the most
perfect and complete manual in
the world immediately.

Our support email:

ebooklibonline@outlook.com