

Section: GEAR
REAR AXLE

Fig.	P/n	QTY	Name
------	-----	-----	------

Notes:
 [IRON 165 S]

4	04428944	1	register
12	04428945	1	register
15	04417450	2	ring 117.07x3.53
30	04417449	2	plate
35	04435695	4	screw m 8 x 16
40	04435703	2	pin 5 x 20
66	0.010.2971.2	2	plate
67	04427625	16	screw m 12 x 40
68	04428220	2	oil seal 305x4

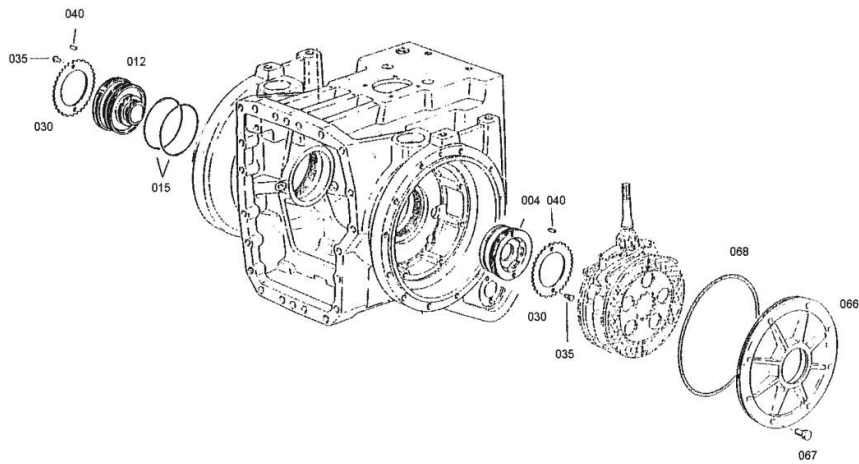

Section: GEAR
SERVICE BRAKE

Fig.	P/n	QTY	Name
------	-----	-----	------

Notes:
 [IRON 165 S]

10	04428541	2	brake disc
20	04436310	2	stop
22	0.010.2900.0	2	screw m 8 x 16
25	04428543	2	operation
30	04426602	10	disc
35	04435745	8	thin plate
40	04435698	6	screw
70	04434557	4	nut m 14 p.1.5
80	04428544	2	bush
120	04428545	1	tube sx/lh/li
130	04428546	1	piping dx/rh/re
140	04428547	2	fascia
150	0.010.2900.1	2	screw m 5 p.0.8 x 25
160	0.010.2900.2	2	screw m 5
170	0.010.2901.0	2	nut m 6
180	04428548	2	pin
185	04428549	2	small disc
190	04428550	2	spring
195	04428551	2	rod
200	04428552	2	pin
205	04428553	2	split pin

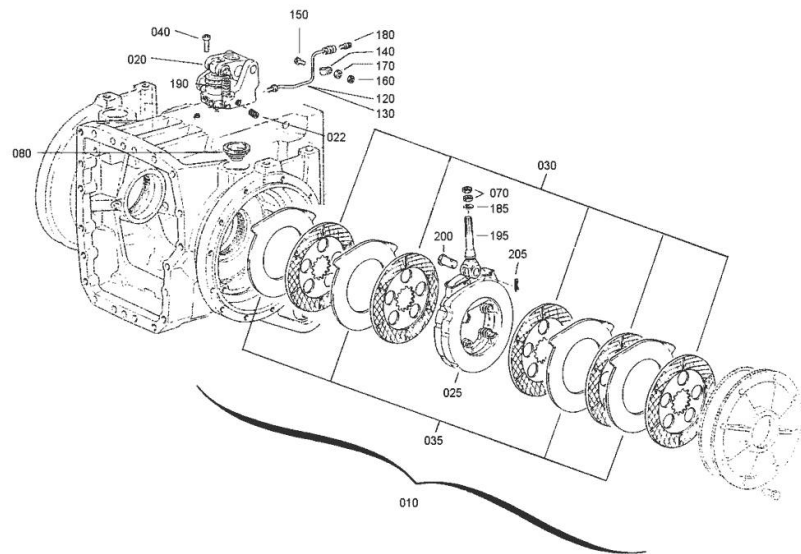

Section: GEAR

BRAKE CONTROLS

Fig.	P/n	QTY	Name
------	-----	-----	------

Notes:
[IRON 165 S]

10	0.010.2901.2	1	support
20	0.010.2902.0	2	bushing
30	0.010.2902.1	2	pin
40	0.010.2902.2	2	connecting rod
50	0.010.2903.0	1	brake lever
60	0.010.2903.1	1	shaft
70	0.010.2903.2	2	nut
80	0.010.2888.2	1	pin 8 x 50
90	0.010.2904.0	2	washer 10.5
100	0.010.2904.1	2	split pin 3.2x18
110	0.010.2904.2	1	ring
120	04435705	3	screw m 8 p.1.25 x 20
130	0.010.2901.1	1	pin 6x50

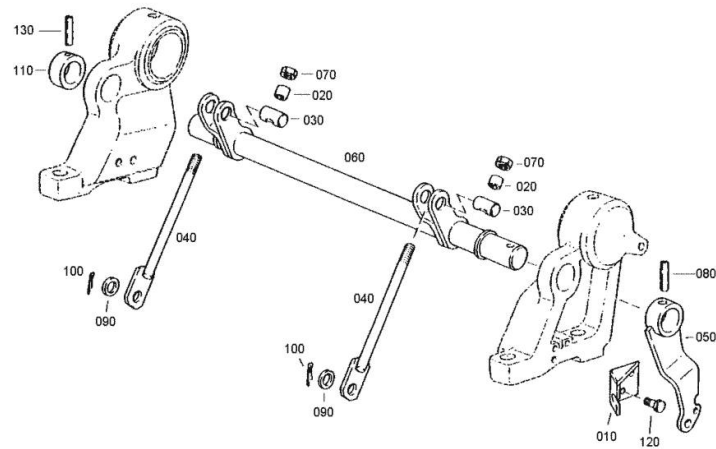

Section: GEAR

LIFTING

Fig.	P/n	QTY	Name
------	-----	-----	------

Notes:
[IRON 165 S]

16	0.010.2907.0	1	shaft
17	04417546	1	bushing
21	04436311	1	bearing block dx/rh/re
26	04436312	1	bearing block sx/lh/li
30	04417549	2	special bushing
55	04417550	4	screw m 20x65
65	04427636	2	grease gun m 8 p.1 x 8
70	04417552	2	ring 78.5x6

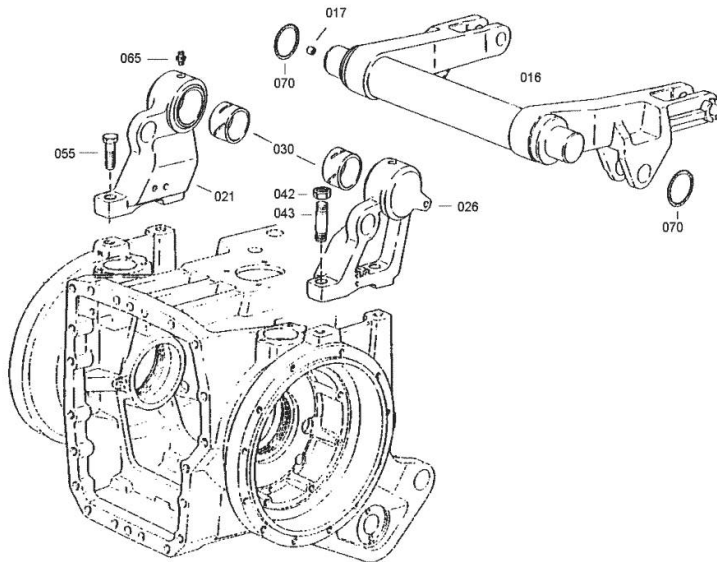

Section: GEAR

CONTROL UNIT - GEARS

Fig.	P/n	QTY	Name
------	-----	-----	------

Notes:
[IRON 165 S]

4	04423824	1	spool valve
30	04417555	2	valve
40	04417556	4	ring
72	04423818	2	small guard
200	04417563	2	screw m 10 x 1
210	0.010.2905.1	2	gasket 10x13.5
225	0.010.2628.2	1	control
227	04422923	2	gasket set
232	0.010.2905.2	2	screw m 8x95
235	04417441	2	screw m 14x1.5
240	04423731	2	oil seal 14 x 18

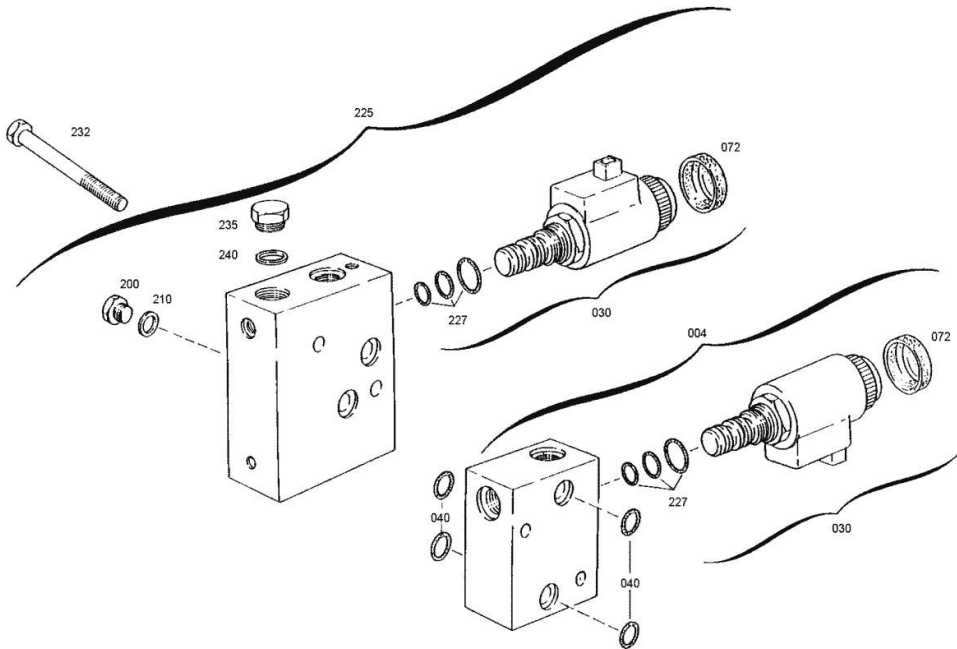

TRANSMISSION CONTROL LEVERS

Fig.	P/n	QTY	Name
1	04422746.4/10	1	lever
2	04411538.4	1	knob
3	04414531	1	switch
4	04436298	1	cap
5	04429989	1	rod
6	06214004	1	sleeve
7	04422755	1	support
8	04429992	1	oil seal

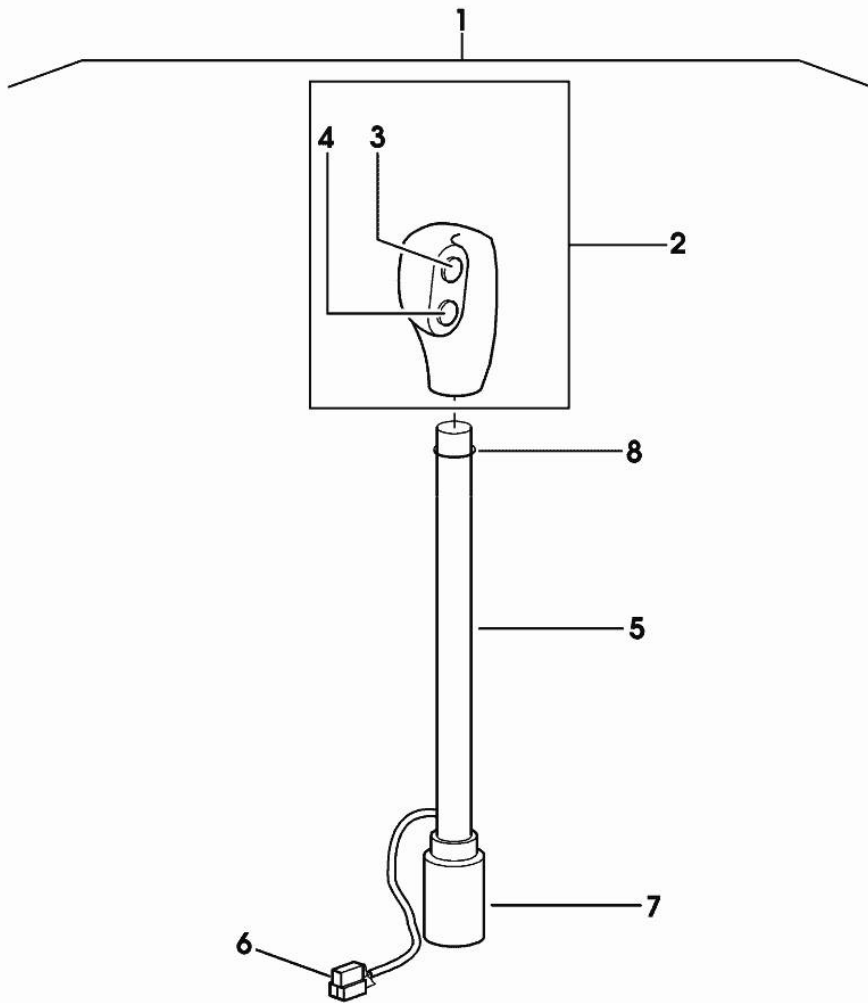

04422746_4_10

Section: REAR AXLE
BRAKE CONTROLS

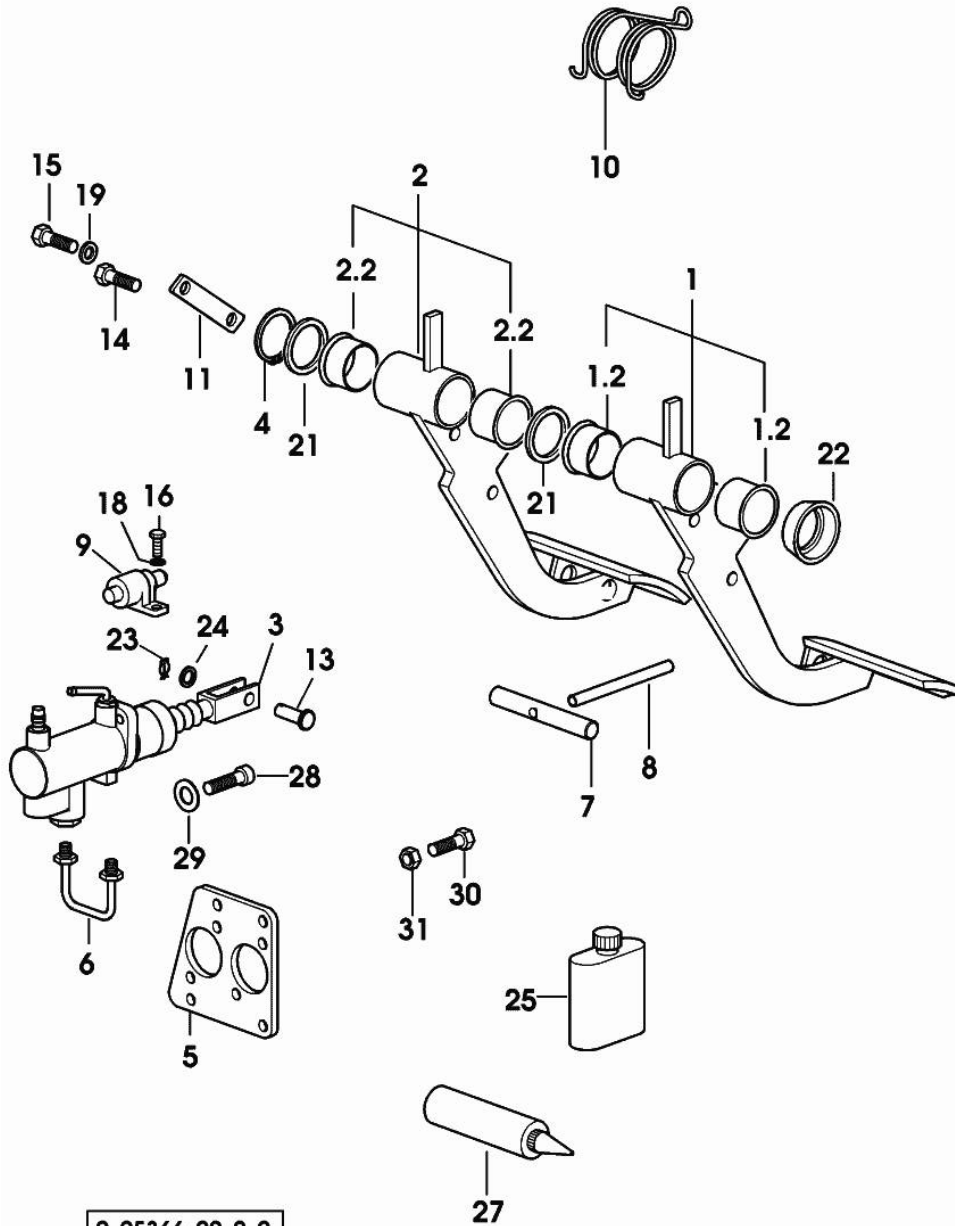

Fig.	P/n	QTY	Name
Notes:			
[IRON 165 S]			
1	04451653.4/10	1	pedal dx/rh/re
1.2	2.1559.117.0/20	2	special bushing 30x34x20
2	04451654.4/10	1	pedal sx/lh/li
2.2	2.1559.117.0/20	2	special bushing 30x34x20
3	04429065	2	cylinder 1062 <- X IRON 130 S 1042 <- X IRON 140 S 1044 <- X IRON 150 S 1054 <- X IRON 165 S
3	04452974.4	2	cylinder -> 1063 X IRON 130 S -> 1043 X IRON 140 S -> 1045 X IRON 150 S -> 1055 X IRON 165 S ☞ 04452974.4
4	01107742	1	circlip 30x1.5
5	04429383	1	support
6	04429067	1	tube
7	02386782	1	pin
8	01171750	1	pin
9	04391395	2	switch
10	0.012.9569.2	1	spring
11	04429702	1	link
13	04429518	2	pin
14	01112322	8	screw m 8 p.1.25 x 20
15	01112307	2	screw m 8 p.1.25 x 15, d933
16	01127017	4	screw m4x12
18	01119806	4	washer 4,3x12x1 d9021
19	01151019	1	washer 8.4
21	2.1599.268.0	2	shoulder ring
22	2.1599.546.0	1	washer 30.5
23	01175876	2	split pin
24	01107105	2	washer 10.5
25	01005149		genuine lubricants H 685 -DEUTZ S2- 1 KG
27	01009463		sealing compound H 699 -DEUTZ DW 43
28	01110577	4	screw m 8 x 25
29	01107101	4	washer 8.4
30	01112350	2	screw m 8 x 35
31	01112824	2	nut m 8, d934

Section: REAR AXLE
BRAKE CONTROLS

Fig.	P/n	QTY	Name
------	-----	-----	------

Notes:
 [IRON 165 S]

1	04432281	1	tank COMPONENT PARTS SEE COMPONENTS LIST ☞ 04432281
2	04429566	1	pipng sx/lh/li
3	04429567	1	pipng dx/rh/re
4	01144700	1	clamp DIN 3017- 100-120
15	04433699		guard
16	01218045	9	rubber plug
23	04426352	9	screw m 8 p.1.25 x 20
24	01107101	10	washer 8.4
25	04415735	2	flange
26	01121654	2	stop
28	01113381	1	stud bolt m 8x20 DIN 939
29	01112824	1	nut m 8, d934
30	01009463		sealing compound H 699 -DEUTZ DW 43
31	04422366	2	tube

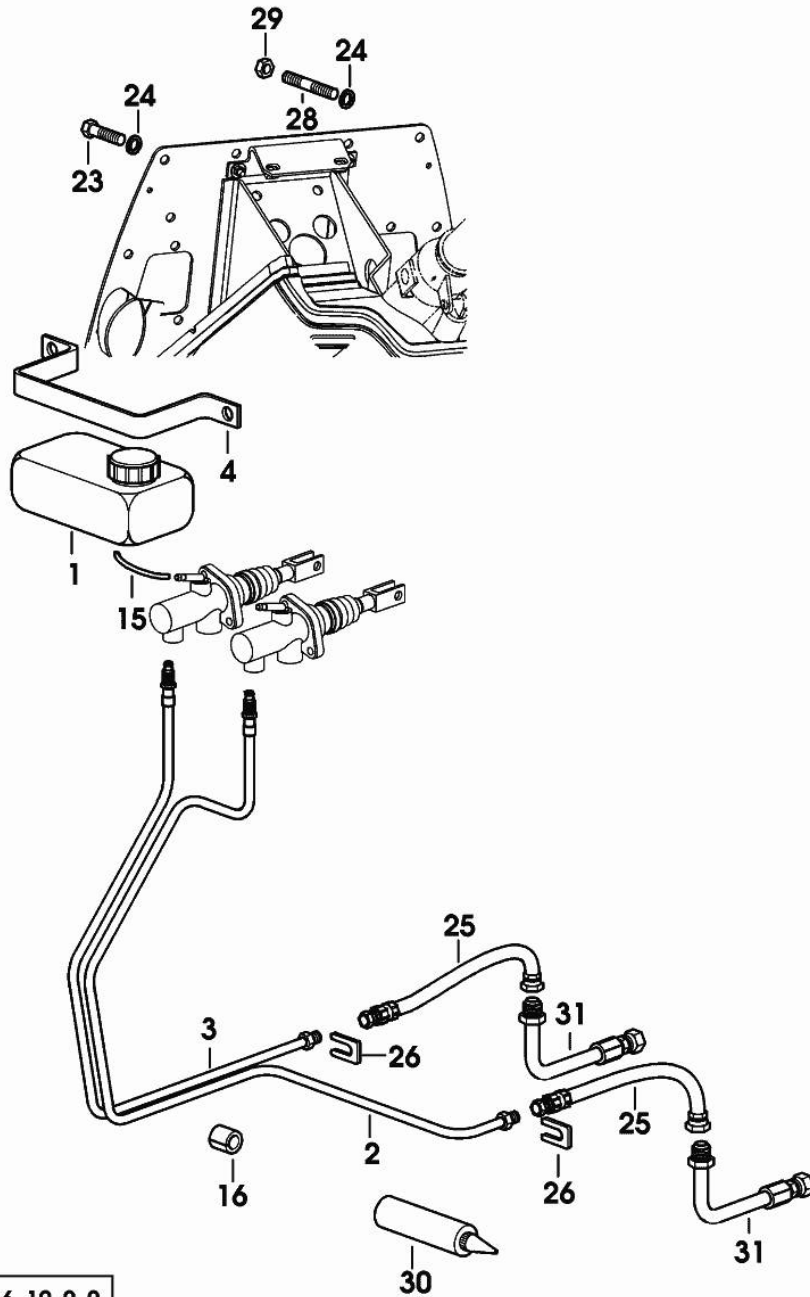

9_95366_10_0_0

Section: REAR AXLE

HAND BRAKE

Fig.	P/n	QTY	Name
------	-----	-----	------

Notes:
[IRON 165 S]

1	04429643.4	1	handbrake lever
1.1	04429486.4	1	lever
1.2	04429487	1	rod
1.3	04429743	1	spring
1.4	04338409	1	push-button
1.5	04365615	1	grip
1.6	04431592	1	ratchet
1.7	04429737	1	pin
1.8	01151019	1	washer 8.4
1.9	01143001	1	split pin 2x16
1.10	01115420	1	pin
1.11	04429881	1	toothed sector
1.12	04428847	1	pin
1.13	01107721	2	circlip
1.15	04429738	1	pin Ø 10x26
1.17	01132625	1	split pin 3.2 x 20
1.18	04428850	1	spacer 7x15x13.75
1.19	01133500	1	nut vm 6 d980
1.20	01112279	1	screw m 6 p.1 x 40
1.21	01112240	2	screw m 6 x 12
1.26	04429651	1	rod
1.31	04429712	1	support
1.32	04391395	1	switch
1.33	01151013	2	washer
1.34	01119629	2	screw m 4.0 x 12
1.35	01115416	1	pin
9	01112322	4	screw m 8 p.1.25 x 20
11	01167317	1	plug 14.5X11.5X21
12	04429746/10	1	plate

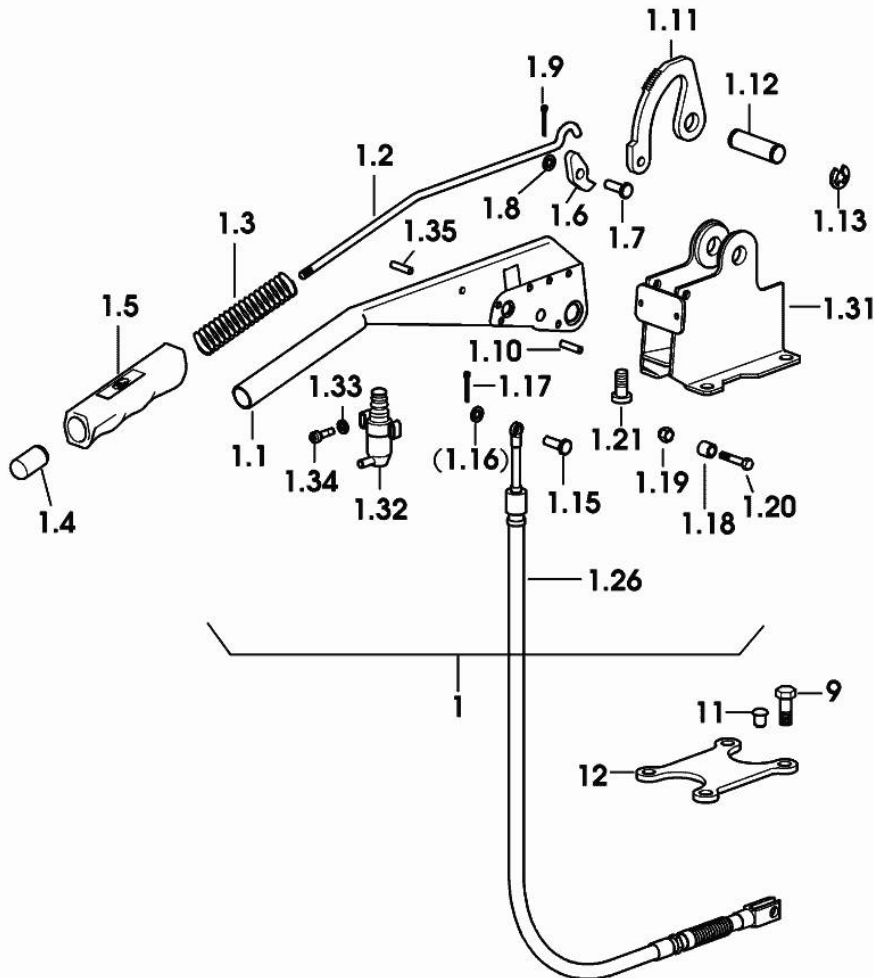

9_95366_05_0_0

Section: REAR AXLE

HAND BRAKE

Fig.	P/n	QTY	Name
------	-----	-----	------

Notes:
[IRON 165 S]

2	01112350	5	screw m 8 x 35
3	04432197	1	pin
4	01132625	1	split pin 3.2 x 20
5	04431563	1	spring
6	04355272	1	bushing 9x13x16
7	01151019	1	washer 8.4
8	01107105	1	washer 10.5

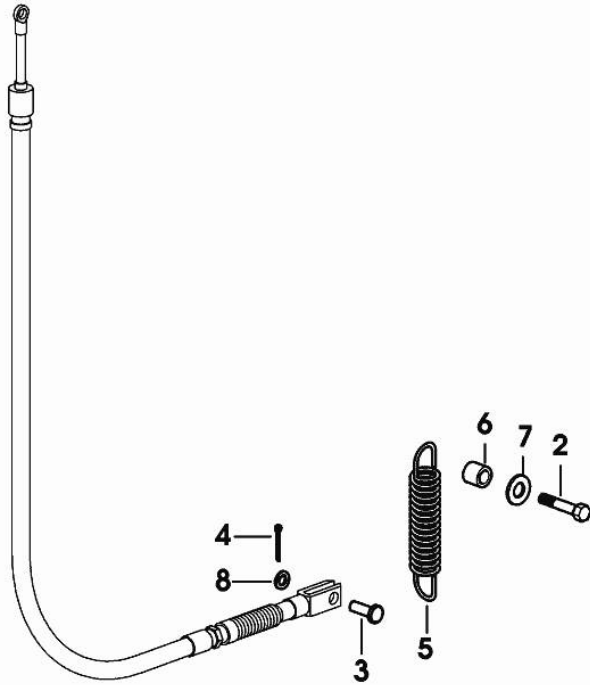

9_95366_04_0_0

TANK - PARTS

Fig.	P/n	QTY	Name
1	04432281	1	tank
2	04438477	1	cover
3	04414695	1	ring
4	04305837	1	pipe fitting 6, d128

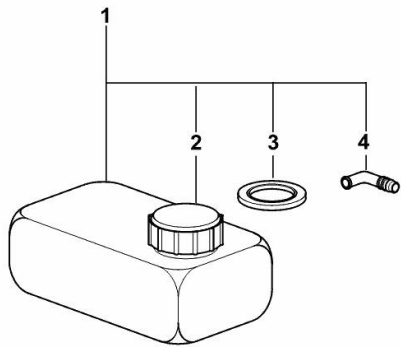

04432281

MASTER CYLINDER PARTS

Fig.	P/n	QTY	Name
1	04452974.4	1	cylinder
2	0.900.2157.7	1	tube
3	0.900.2157.8	1	gasket

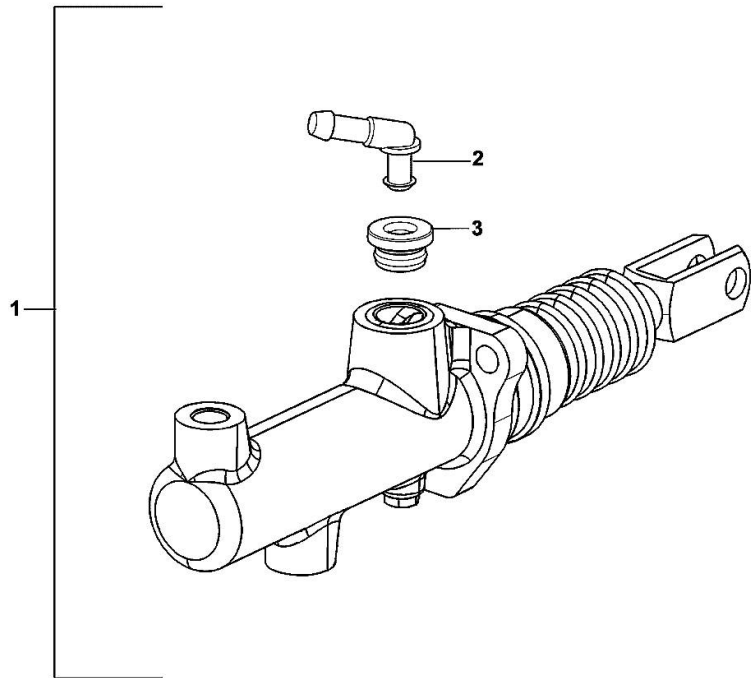

04452974.4

Section: FRONT AXLE

FRONT SUPPORT

Fig.	P/n	QTY	Name
------	-----	-----	------

Notes:
[IRON 165 S]

1	04422720	1	support
2	04411024	1	pin
3	01112515	2	screw m 12 x 25
4	04419914	1	bracket
5	04388695	2	bushing 17x22x23
6	06273759	4	screw m 16 h6 x 100
7	01144479	4	screw m 16 x 120

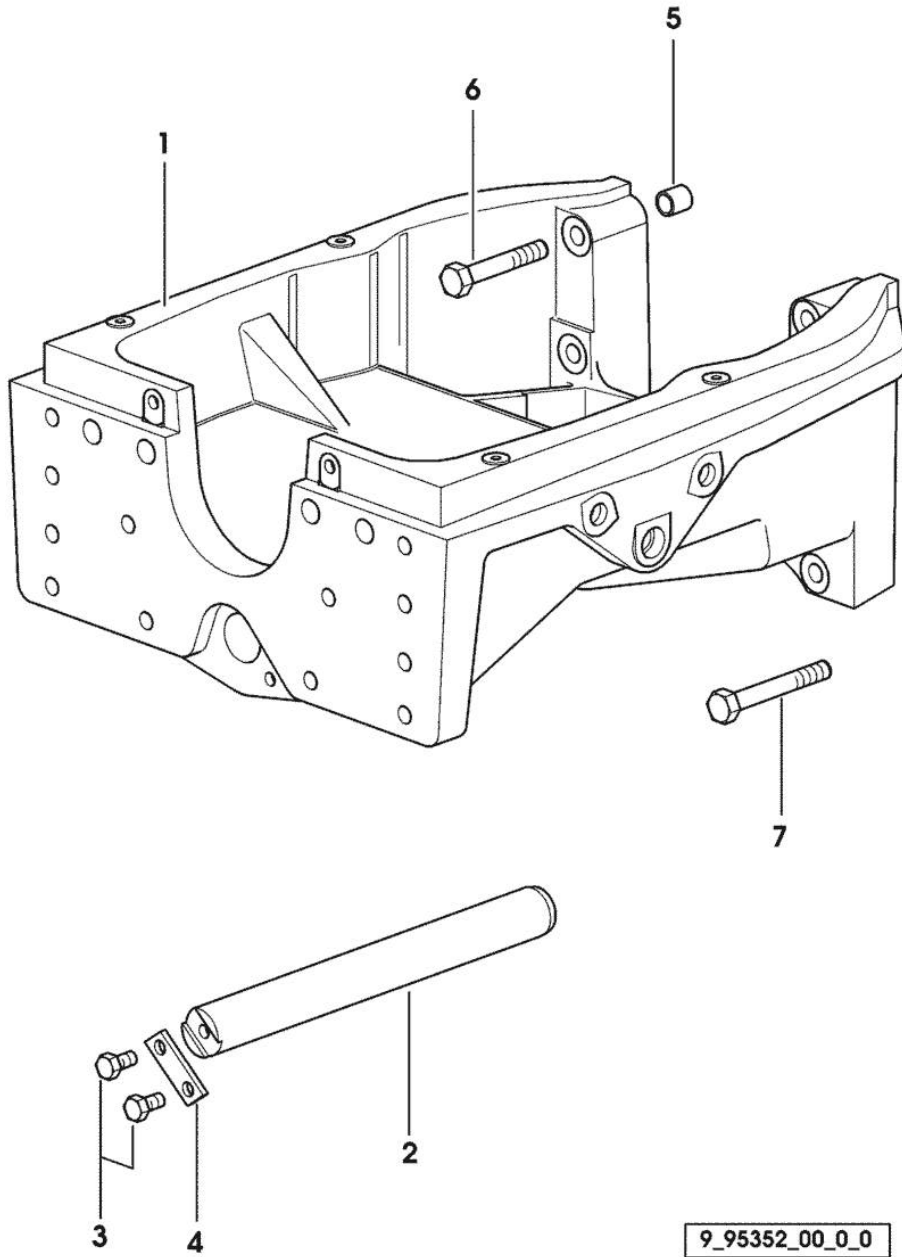

9_95352_00_0_0

Section: FRONT AXLE

FRONT CARRIER WITH SUSPENSION

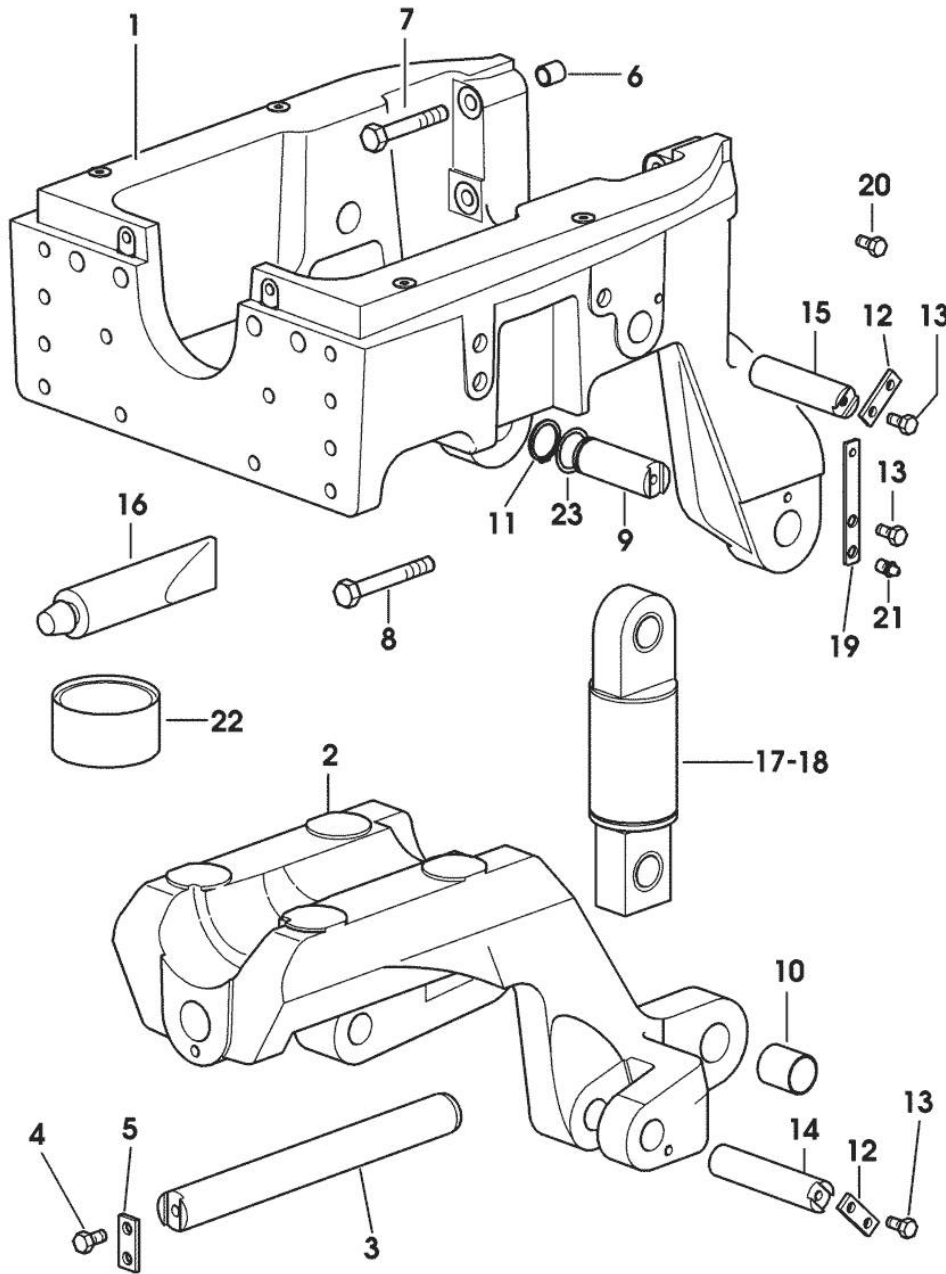

Fig.	P/n	QTY	Name
------	-----	-----	------

Notes:
[IRON 165 S]

1	04416880/20	1	axle support
2	04416882/20	1	rocker arm
3	04411024	1	pin
4	01112515	2	screw m 12 x 25
5	04411025	1	flange
6	04388695	2	bushing 17x22x23
7	06273759	4	screw m 16 h6 x 100
8	01144479	4	screw m 16 x 120
9	04438671	2	pin
10	04424134/20	2	bushing
11	01107755	2	ring 40 x 1,75, d471
12	04422768	6	small plate
13	01112418	10	screw m 10 x 25, d933
14	04419865	2	pin
15	04419866	2	pin
16	01016112		adhesive H 699 - DEUTZ DW 59
17	0.013.9105.4	1	cylinder dx/rh/re COMPONENT PARTS SEE COMPONENTS LIST ☞ 0.013.9105.4
18	0.013.9104.4	1	cylinder sx/lh/li COMPONENT PARTS SEE COMPONENTS LIST ☞ 0.013.9104.4
19	04422860/10	1	small plate
20	04450386	2	screw m 10 x 25
21	01168224	2	grease gun m 6
22	01098022	1	oil
23	04438682	2	ring

9_95352_01_0_0

ELECTR. EQUIPMENT - SPRUNG FRONT AXLE

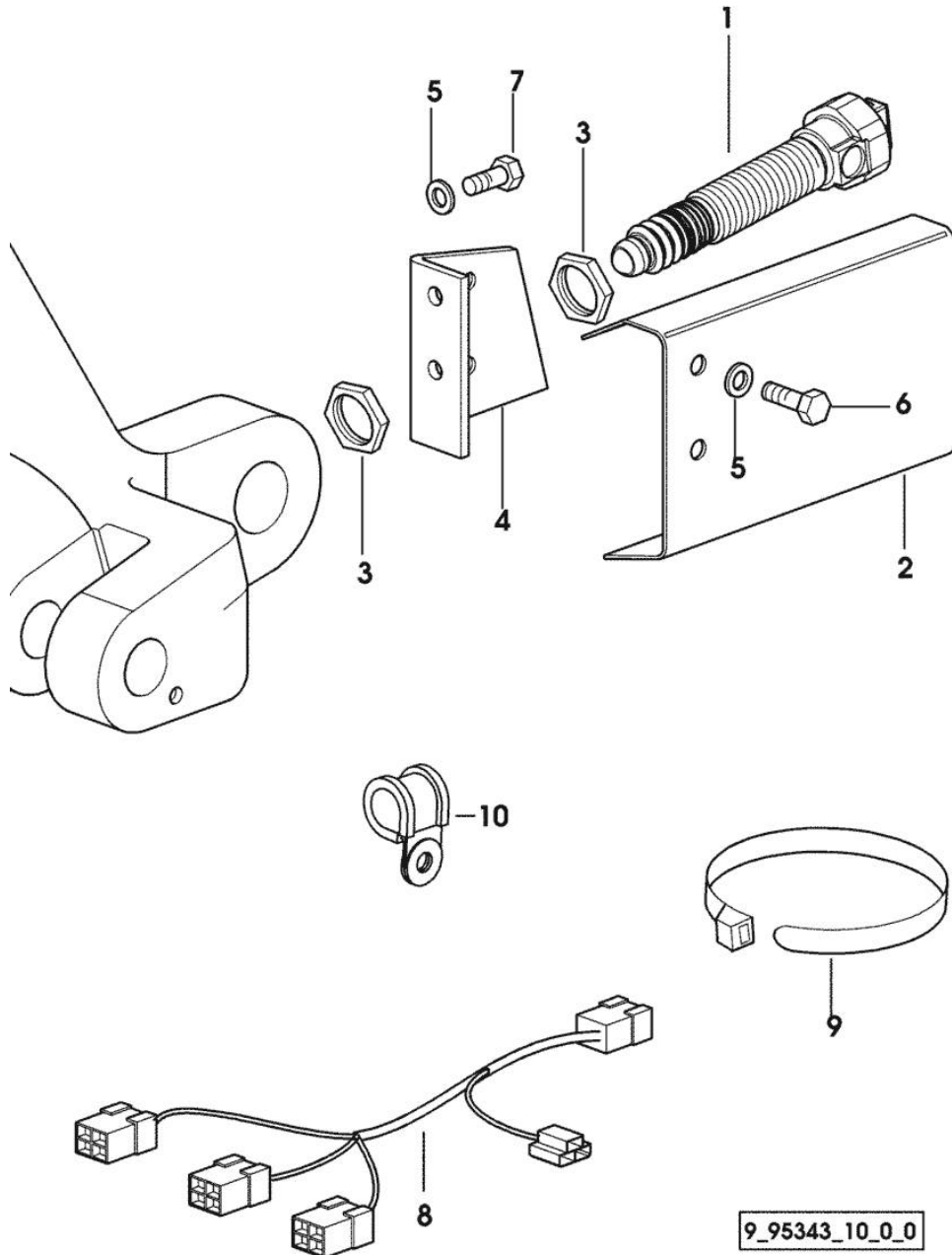

Fig.	P/n	QTY	Name
------	-----	-----	------

Notes:
[IRON 165 S]

1	0.009.2194.4	1	sensor
2	04422564	1	square
3	01127817	2	nut M24x1.5
4	04426199.4	1	console
5	01138374	4	washer 8,4x21x4
6	01112333	2	screw m 8 x 25, d933
7	01112299	2	screw m 8 x 12, d933
8	04437849	1	electrical system
9	01080571	10	band 172X4.6
10	04327529	1	fascia 10,7

9_95343_10_0_0

Thank you so much for reading.
Please click the “Buy Now!”
button below to download the
complete manual.



After you pay.

You can download the most
perfect and complete manual in
the world immediately.

Our support email:

ebooklibonline@outlook.com