

CRANKCASE

Fig.	P/n	QTY	Name
------	-----	-----	------

Notes:

[JOKER 60 E 2WD ->H10S553WX1E1001] [JOKER 60 E 4WD ->H10S553WT1E1001]

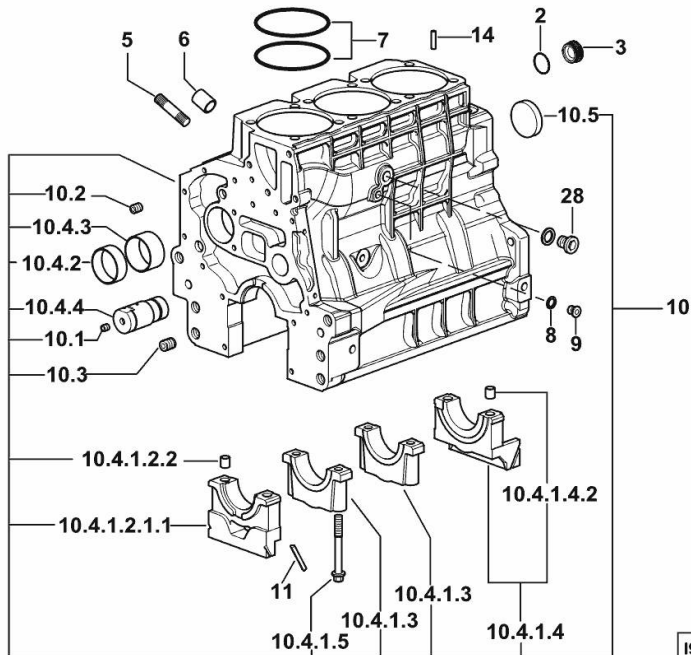

19_N8111_00_0-A-002

2	2.1532.072.0	1	oil seal 26.70x1.78
3	2.3199.405.2	1	plug m 28 p.1.5
5	2.0432.003.7	11	stud bolt m 8 p.1.25 / p.1 x 20
6	2.1559.188.2	3	bush 11.4 x 14 x16
7	2.1539.259.0	6	special oil seal 107.62x2.62
8	2.1560.010.0	1	gasket 14.2 x 20
9	2.3199.292.0	1	plug 1/4" gas
10	0.014.8700.4	1	crankcase
10.1	2.3130.001.1	9	plug 1/8" gas
10.2	2.3130.002.1	2	plug 1/4" gas
10.3	2.3130.003.1	2	plug 3/8" gas
10.4.1.2.1.1	0.065.1112.7/10	1	support
10.4.1.2.2	2.1699.165.0	1	bush 12.3x15x16
10.4.1.3	0.065.1114.0/10	2	support
10.4.1.4	0.065.1116.3	1	support
10.4.1.4.2	2.1699.165.0	1	bush 12.3x15x16
10.4.1.5	0.065.1117.0	8	screw m 12 x 100
10.4.2	0.065.1140.0	3	special bushing 59X55X20
10.4.3	0.065.1141.0	1	special bushing 59X55X30
10.4.4	0.014.1340.0	1	pin
10.5	2.3179.012.0	1	plug 60
11	0.066.1152.0/10	4	gasket
14	2.1549.154.2	3	bush 4.8x5.8x16
28	2.3131.004.2	1	plug m 18 p.1.5

MONOBLOC ENGINE-GEARBOX CONNECTING FLANGE

Fig.	P/n	QTY	Name
------	-----	-----	------

Notes:

[JOKER 60 E 2WD ->H10S553WX1E1001] [JOKER 60 E 4WD ->H10S553WT1E1001]

1	0.015.8814.0	1	flange
2	2.0112.511.2	8	screw m 14 p.2 x 30
3	2.0432.255.7	2	stud bolt m 12 p.1.75-1.25x25
4	2.1651.912.0	4	cylindrical plug 12x28
5	2.0512.404.7	2	screw

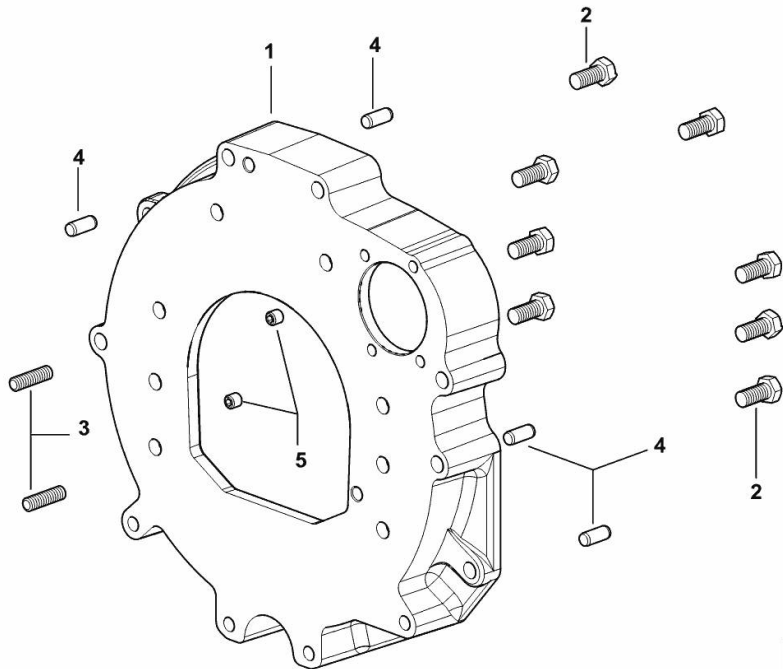

I9_38511_01_0-A-001

FITTING FOR ENGINE OIL PRESSURE SWITCH

Fig.	P/n	QTY	Name
------	-----	-----	------

Notes:

[JOKER 60 E 2WD ->H10S553WX1E1001] [JOKER 60 E 4WD ->H10S553WT1E1001]

30	2.1560.008.0	2	gasket 12.2 x 18
31	2.3339.448.2	1	pipe union m 12 p.1.75
32	2.3249.014.2	1	pipe fitting m 12 p.1.5

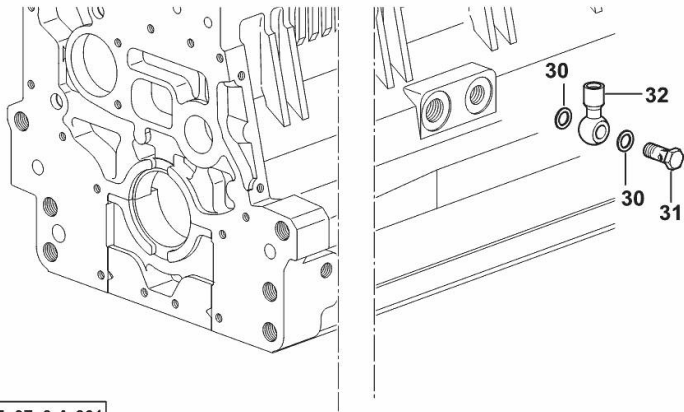

19_36215_07_0-A-001

CRANKSHAFT

Fig.	P/n	QTY	Name
------	-----	-----	------

Notes:

[JOKER 60 E 2WD ->H10S553WX1E1001] [JOKER 60 E 4WD ->H10S553WT1E1001]

7.1	0.007.1554.0/20	1	crankshaft
8	0.065.1215.0/10	4	main half bushing STANDARD
9	0.065.1216.0/10	4	main half bushing STANDARD
10	0.065.1218.0	4	shim STANDARD
15	0.065.1254.0/20	1	gasket
16	0.007.1711.0/10	1	cover
17	2.1475.002.2	9	conical washer 8
18	2.0112.207.2	9	screw m 8 p 1.25 x 20
19	2.1529.073.0	1	special oil seal 110x130x13
22	2.1599.524.7	1	washer 21x60x12
23	0.065.1323.0/30	1	gear Z = 29
24	2.1651.915.0	1	pin 12x35
25	2.3130.001.1	3	plug 1/8" gas
26	2.1720.006.0	1	key 4x6.5
801	0.065.1215.7	1	main half bushing - mm 0.25
802	0.065.1215.8	1	main half bushing - mm 0.50
901	0.065.1216.7	1	main half bushing - mm 0.25
902	0.065.1216.8	1	main half bushing - mm 0.50
1001	0.065.1218.7	1	shim + mm 0.10
1002	0.065.1218.8	1	shim + mm 0.15

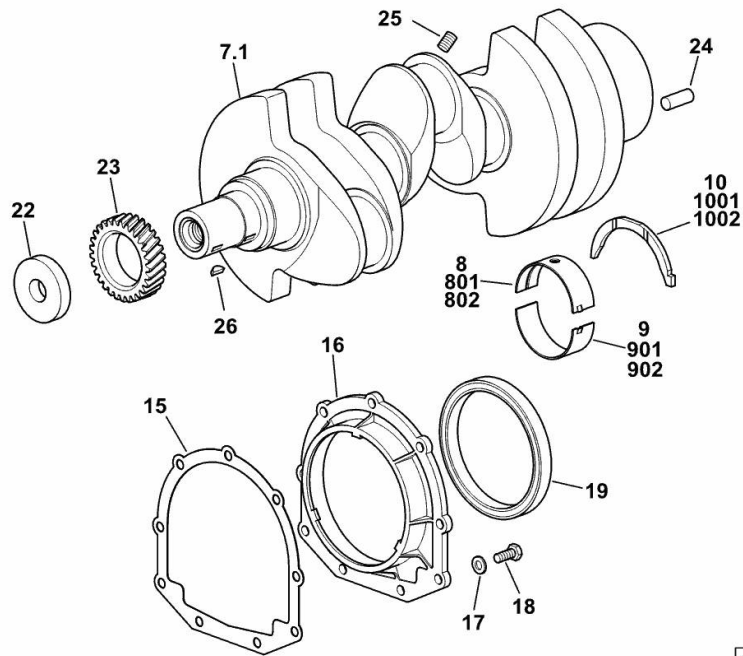

19_N8112_00_0-A-001

CRANKSHAFT

Fig.	P/n	QTY	Name
------	-----	-----	------

Notes:

[JOKER 60 E 2WD ->H10S553WX1E1001] [JOKER 60 E 4WD ->H10S553WT1E1001]

7	0.019.2255.0/20	1	crankshaft
8	0.019.5455.0	4	main half bushing STANDARD
9	0.019.5456.0	4	main half bushing STANDARD
10	0.065.1218.0	4	shim STANDARD
15	0.065.1254.0/20	1	gasket
16	0.007.1711.0/10	1	cover
17	2.1475.002.2	9	conical washer 8
18	2.0112.207.2	9	screw m 8 p 1.25 x 20
19	2.1529.073.0	1	special oil seal 110x130x13
22	2.1599.524.7	1	washer 21x60x12
23	0.065.1323.0/30	1	gear Z = 29
24	2.1651.915.0	1	pin 12x35
26	2.1720.006.0	1	key 4x6.5
1001	0.065.1218.7	1	shim + mm 0.10
1002	0.065.1218.8	1	shim + mm 0.15

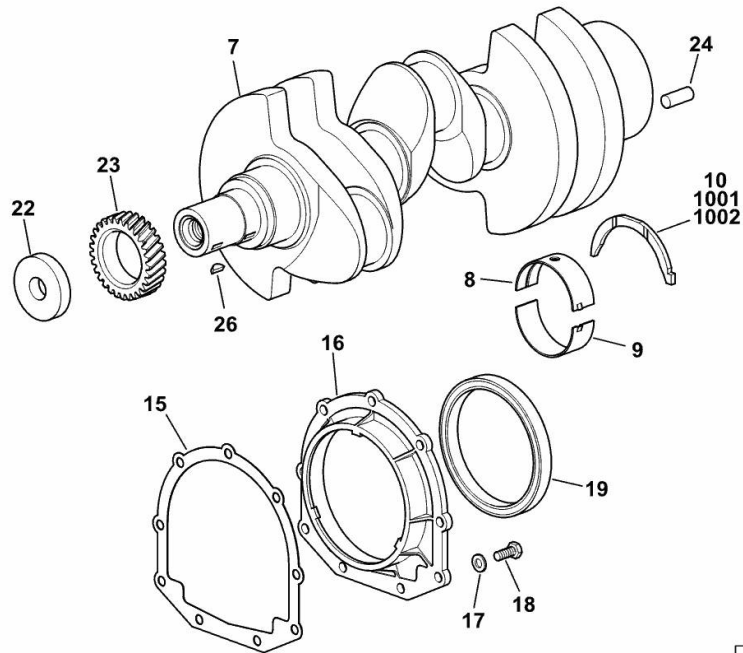

19_N8112_00_0-A-002

ENGINE FLYWHEEL

Fig.	P/n	QTY	Name
------	-----	-----	------

Notes:

[JOKER 60 E 2WD ->H10S553WX1E1001] [JOKER 60 E 4WD ->H10S553WT1E1001]

1	0.012.0925.3	1	flywheel
1.2	0.069.1242.0	1	crown wheel Z = 121
2	2.0119.174.0/10	6	screw m 12 p.1.25x45
3	2.2041.008.9	1	ball bearing 20x47x14

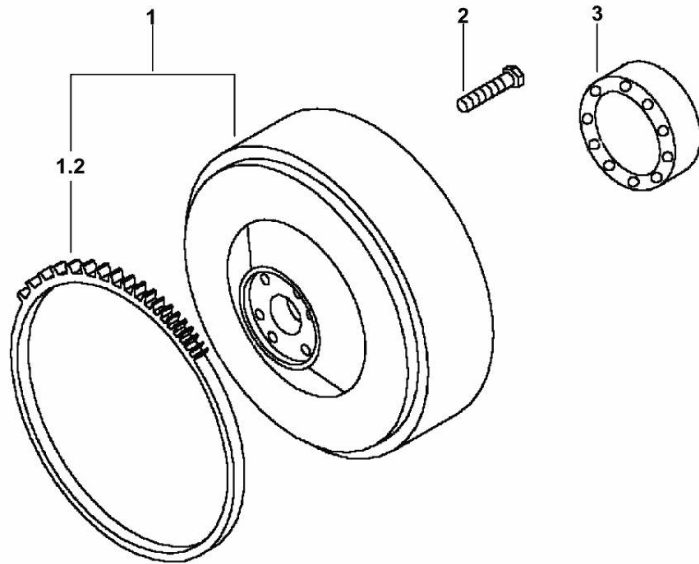

19_38512_02_0-A-001

ENGINE FLYWHEEL

Fig.	P/n	QTY	Name
------	-----	-----	------

Notes:

- FOR TYPES WITH DOUBLE CLUTCH [JOKER 60 E 2WD ->H10S553WX1E1001] - FOR TYPES WITH DOUBLE CLUTCH [JOKER 60 E 4WD ->H10S553WT1E1001]

1	0.007.1617.3/30	1	flywheel
1.2	0.069.1242.0	1	crown wheel Z = 121
2	2.0119.174.0/10	6	screw m 12 p.1.25x45
3	2.2041.008.9	1	ball bearing 20x47x14

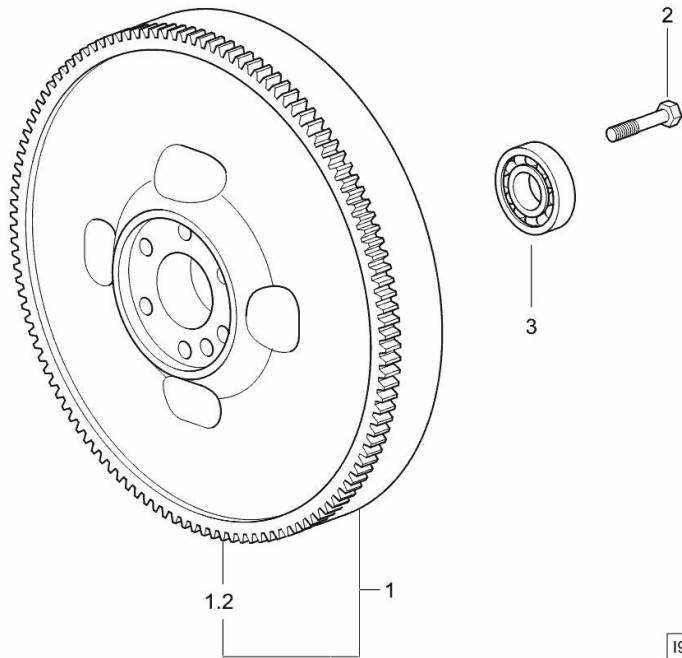

19_38512_12_0-A-001

CRANKSHAFT PULLEY

Fig.	P/n	QTY	Name
------	-----	-----	------

Notes:

[JOKER 60 E 2WD ->H10S553WX1E1001] [JOKER 60 E 4WD ->H10S553WT1E1001]

3	0.014.5093.0	1	pulley
5	0.085.1248.0/20	1	hub
6	2.0399.144.7/10	1	screw m 20 p.1.5x51
8	2.1720.006.0	1	key 4x6.5

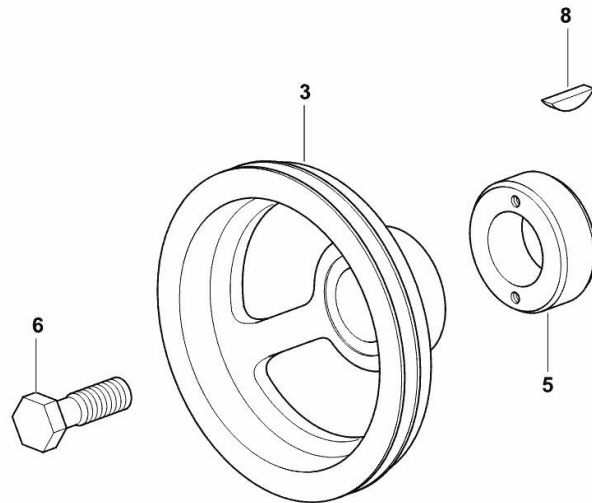

19_38512_04_0-A-001

COOLANT PUMP AND ALTERNATOR DRIVEBELT

Fig.	P/n	QTY	Name
------	-----	-----	------

Notes:

[JOKER 60 E 2WD ->H10S553WX1E1001] [JOKER 60 E 4WD ->H10S553WT1E1001]

3	2.4119.198.0	1	vee belt AV 10.7x1240 mm
---	--------------	---	--------------------------

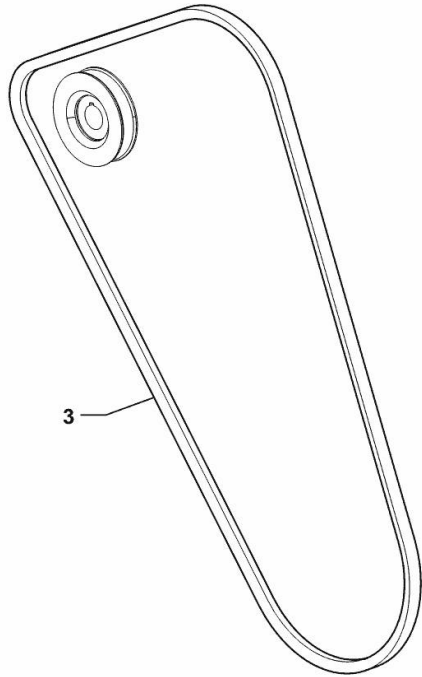

19_O2519_11_0-A-001

CYLINDER - PISTON - CONNECTING ROD

Fig.	P/n	QTY	Name
------	-----	-----	------

Notes:

[JOKER 60 E 2WD ->H10S553WX1E1001] [JOKER 60 E 4WD ->H10S553WT1E1001]

1	0.386.0065.A	3	cyl. piston assembly "A" - CLASS A
1	0.386.0065.B	3	cyl. piston assembly "B" - CLASS B
1.1	0.A12.2675.0	1	engine cylinder "A" - CLASS A
1.1	0.B12.2675.0	1	engine cylinder "B" - CLASS B
1.2	0.379.0060.A	1	complete piston "A" - CLASS A
1.2	0.379.0060.B	1	complete piston "B" - CLASS B
1.2.1	0.086.0052.6/10	1	piston ring set
1.2.2	2.1411.014.1	1	circlip 35
1.2.3	0.078.1236.0	1	piston pin Ø 18 / Ø 35 / L = mm 86
2	0.065.1225.0	6	con.rod half bushing STANDARD - A = 28.75 -> 29.00 (...) <=
2	0.065.1225.7	6	con.rod half bushing - mm 0.25 (...) <=
2	0.065.1225.8	6	con.rod half bushing - mm 0.50 (...) <=
3	0.019.2226.3/10	1	engine connecting rod => (...)
3	0.078.1220.3/30	1	engine connecting rod (...) <=
3.1	2.0399.213.0	2	screw m 12 p.1.25x61.5 (...) <=
3.1	2.0399.365.0	2	screw m 10 p.1.25x61.5 => (...)
3.2	2.1559.114.0/10	1	special bushing (...) <=
3.2	2.1559.532.0	1	special bushing 34.60x39.130x36.65 => (...)
4	0.019.5453.0	3	con.rod half bushing STANDARD - A = 29.85 -> 30.10 => (...)
5	0.019.5454.0	3	con.rod half bushing STANDARD - A = 29.85 -> 30.10 => (...)

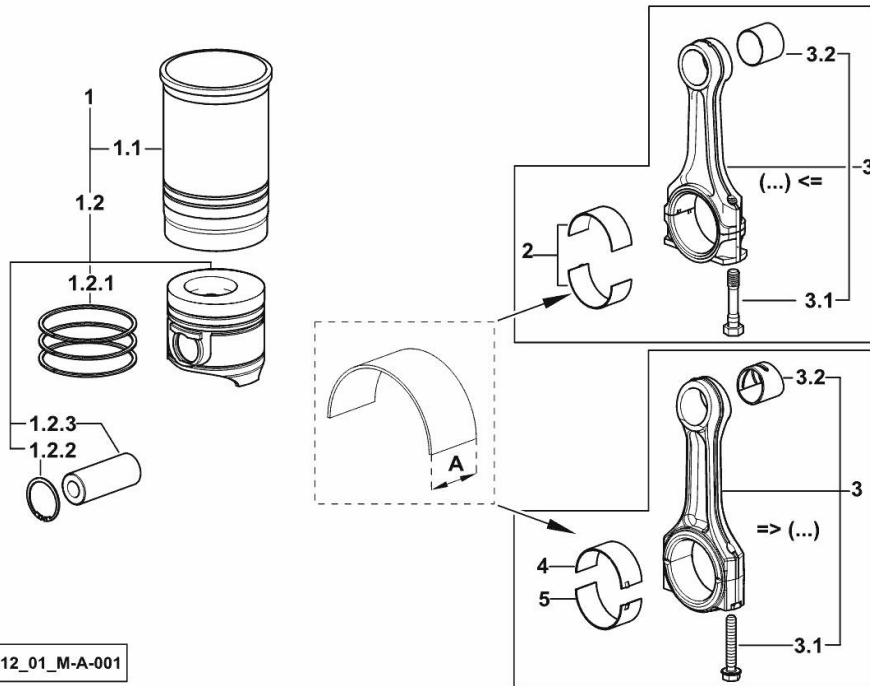

CAMSHAFT

Fig.	P/n	QTY	Name
------	-----	-----	------

Notes:

[JOKER 60 E 2WD ->H10S553WX1E1001] [JOKER 60 E 4WD ->H10S553WT1E1001]

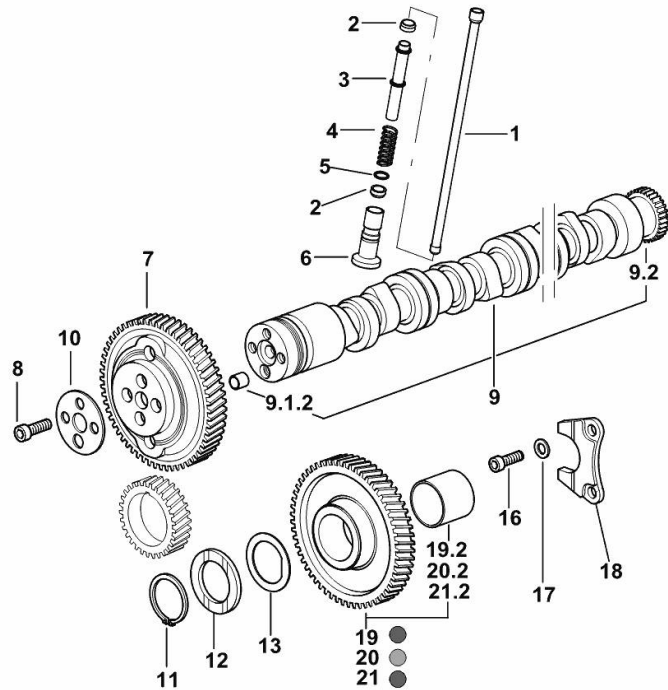

19_N8113_00_0-A-002

1	0.065.1331.2	6	rod
2	2.1569.114.0/10	12	gasket 14x18.5x8
3	0.065.1332.0	6	sleeve
4	2.4019.300.1/10	6	spring 18.5x52x2
5	2.1599.437.0	6	shoulder ring
6	0.065.1330.0	6	tappets
7	0.013.5017.0	1	gear z=58
8	2.0132.207.2	4	screw m 10 p.1 x 25
9	0.012.8270.4	1	camshaft
9.1.2	2.1559.398.0	1	bushing 10.5x13x12
9.2	0.065.1324.0/10	1	gear Z = 32
10	0.065.1350.0	1	small disc
11	2.1410.016.1	1	circlip 40
12	0.065.1352.0	1	shim
13	0.018.2233.0	2	shoulder ring
16	2.0312.205.2	2	screw
17	2.1480.014.1	2	washer 8
18	0.065.1353.0	1	small plate
19	0.007.1177.3/20	0.1	gear z = 57 - WITH RED IDENTIFICATION STAMP
19.2	2.1559.185.0/10	1	bushing
20	0.007.1178.3/20	0.1	gear z = 57 - WITH YELLOW IDENTIFICATION STAMP
20.2	2.1559.185.0/10	1	bushing
21	0.007.1179.3/20	0.8	gear z = 57 - WITH GREEN IDENTIFICATION STAMP
21.2	2.1559.185.0/10	1	bushing

TIMING CASE

Fig.	P/n	QTY	Name
------	-----	-----	------

Notes:

[JOKER 60 E 2WD ->H10S553WX1E1001] [JOKER 60 E 4WD ->H10S553WT1E1001]

5	2.0432.003.7	11	stud bolt m 8 p.1.25 / p.1 x 20
16	2.0312.214.2	7	screw m 8 p.1.25 x 40
17	2.1480.014.1	15	washer 8
18	0.013.4981.0	1	guard
19	0.065.1150.0/30	1	gasket
20	2.1470.004.2	2	lock washer 8
21	2.1011.405.2	2	nut m 8 p.1
22	2.0312.208.2	8	screw m 8 p.1.25 x 25
23	2.1529.167.0	1	oil seal

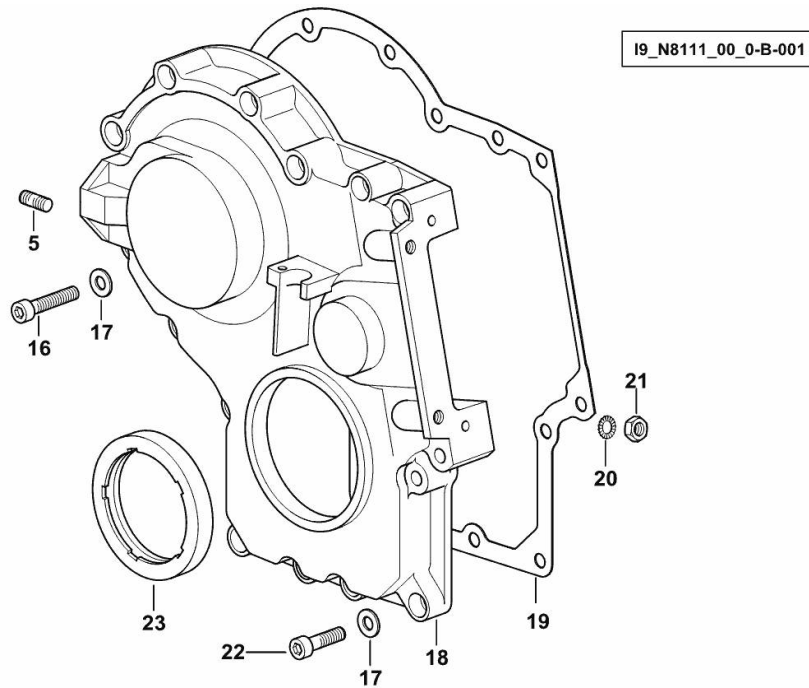

CYLINDER HEAD

Fig.	P/n	QTY	Name
------	-----	-----	------

Notes:

[JOKER 60 E 2WD ->H10S553WX1E1001] [JOKER 60 E 4WD ->H10S553WT1E1001]

1	2.0399.130.2/10	3	screw m 8x36x44
2	2.1569.170.0/10	3	gasket 8.2 x 14
3	0.016.0291.0	3	small cap
4	0.069.1450.0/30	1	tappet gasket
7	2.1011.421.2	6	nut m 10 p.1.25
9.2	0.021.1434.0	2	screw
9.10.3	2.1011.405.2	2	nut m 8 p.1
9.10.4	0.066.1432.3	2	rocker arm
9.10.4.2	2.1559.021.0/40	1	bushing 15x19x22
9.10.5	2.1410.055.7	2	circlip 19
9.10.6.1	0.066.1431.0	1	pin
9.10.6.2	0.066.1430.0/10	1	support
9.10.7	2.1599.432.0	2	shoulder ring
16	2.1530.051.0	3	oil seal 20.22x3.53
17	0.012.2673.0	12	screw m 14 p.2x141
18.1	0.014.8945.3/10	1	head
18.1.2	0.014.8942.0	1	valve seat mm 45.118
18.1.3	0.014.8941.0	1	valve seat mm 40.653
18.1.4	0.007.1779.0/20	2	valve guide
18.1.5	0.010.6041.0/10	1	bush
18.1.6	2.3170.012.2	2	expansion plug Ø 30
18.2	0.066.1421.0	1	exhaust valve
18.3	0.010.6016.0	1	inlet valve mm 43.63 / Ø mm 9
18.4	0.066.1425.0	2	cup
18.5	0.074.1423.0	4	conical valve cotter
18.6	2.4019.287.0	2	spring
18.7	2.1519.117.0	2	special oil seal
18.8	2.0432.161.7	1	stud bolt m 10 p.1.5 / p.1.25 x 40
18.9	2.0432.163.7	2	stud bolt m 10 p.1.5 / p.1.25 x 45
20	2.0432.011.7	3	stud bolt m 8 p.1.25 / p.1 x 40
21	2.0432.005.7	3	stud bolt m 8 p.1.5 / p.1 x 25
25	0.014.5260.0/10	0.5	gasket - A - mm 1.4
26	0.014.5259.0/10	2	gasket - B - mm 1.2
27	0.014.5261.0/10	0.5	gasket - C - mm 1.6

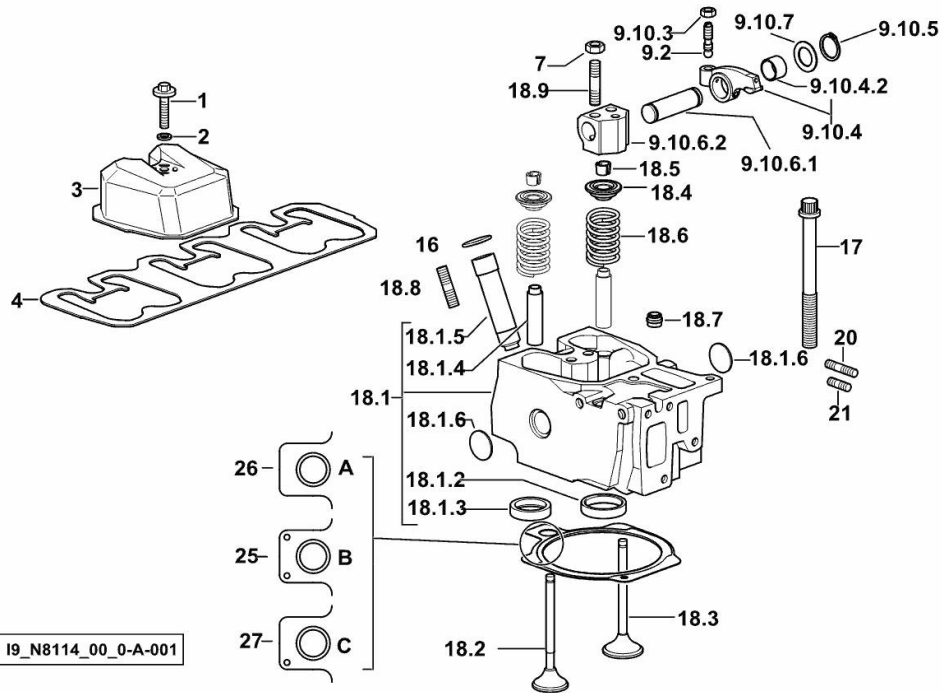

19_N8114_00_0-A-001

ENGINE OIL PUMP

Fig.	P/n	QTY	Name
------	-----	-----	------

Notes:

[JOKER 60 E 2WD ->H10S553WX1E1001] [JOKER 60 E 4WD ->H10S553WT1E1001]

35	0.065.1560.0/30	2	gasket
36	2.0169.005.2	2	screw m 6 p.1 x 12
37	2.1652.711.0	2	cylindrical plug 8x25
38	0.075.1551.4/30	1	support
38.1	0.075.1551.3/40	1	support
38.1.2	2.1559.186.0	1	special bushing 26 x 31.5 x 35
38.2	2.1219.025.2/10	1	ring nut m 36 p.1.5
38.3	2.1410.057.1	1	circlip 15
38.4	2.1589.153.0	1	shoulder ring 15.2 x 19 x 1.00
38.5	2.1589.146.0	2	shoulder ring 15.2 x 19 x 0.15
38.6	2.1589.147.0	2	shoulder ring 15.2 x 19 x 0.10
38.7	2.2020.001.0	1	ball bearing 15 x 32 x 8.00
38.8	2.1589.148.0	1	shoulder ring 28.2 x 31.8 x 0.5
38.9	2.1589.150.0	2	shoulder ring 28.2 x 31.8 x 0.1
38.10	2.1589.151.0	2	shoulder ring 28.2 x 31.8 x 0.15
38.11.1	0.065.1558.6/10	1	bevel drive
38.11.2	0.065.1559.0	1	bush
38.12	2.2680.020.0	1	ring 12 x 15 x 12
38.13	2.2725.016.0	1	roller cage 15 x 21 x 12
38.14	2.0342.007.2	1	screw m 4 p.0.7x25
38.15	2.0399.128.2/10	1	screw m 8 p.1 x 8
38.16	2.2030.002.0	1	ball bearing 12 x 28 x 8
40	0.065.1569.0/40	1	shaft
41	0.065.1562.0/10	1	joint
42	0.014.7994.4	1	oil pump
43	2.1470.006.2	2	lock washer 10
44	2.0112.323.2	2	screw m 10 p.1.5x70

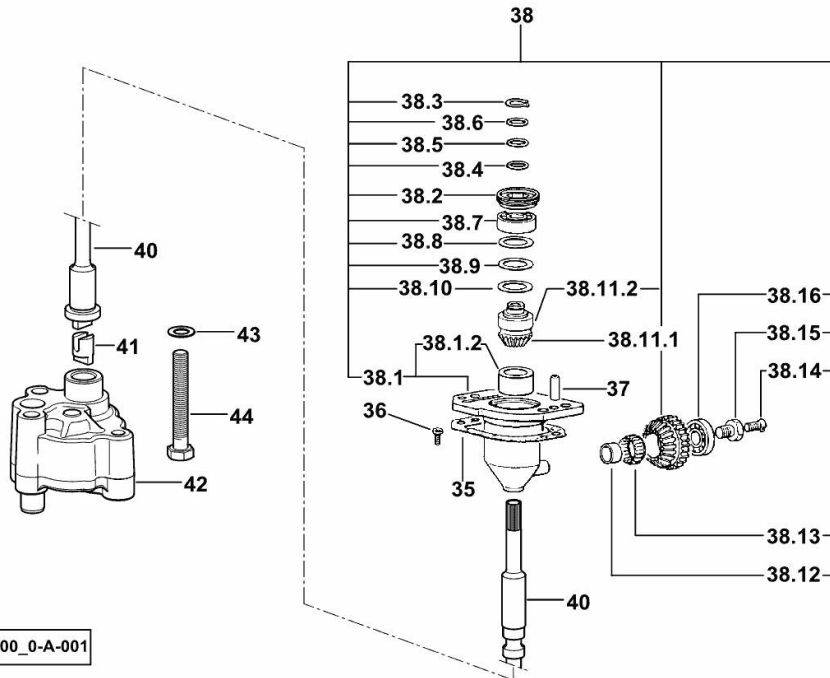

19_38515_00_0-A-001

LUBRICATION

Fig.	P/n	QTY	Name
------	-----	-----	------

Notes:

[JOKER 60 E 2WD ->H10S553WX1E1001] [JOKER 60 E 4WD ->H10S553WT1E1001]

1	0.065.1160.3/20	3	valve
50	2.1099.108.2	3	special nut m 10 p.1
51	2.1560.006.0	12	gasket 10.2 x 16
52	0.086.1550.2	3	sprayer nozzle
55	2.0312.221.2	2	screw m 8 p.1.25x75
56	2.1480.014.1	2	washer 8
57	0.012.0688.4	1	sediment bowl
57.1	0.066.1553.0	1	cover
57.2	0.066.1554.0/20	1	gasket
57.3	2.0399.304.2	4	screw m 4 x 10
57.4.1	0.066.1555.0	1	tube
57.4.2	0.012.0688.0	1	small tank
58	2.1532.012.0	1	oil seal 6.75 x 1.78
59	2.1539.072.0	2	special oil seal 23.52 x 1.78
60	0.066.1558.0	1	bush
61	0.066.1557.2	1	tube
62	2.3350.003.1	1	nosepiece 8
63	2.3339.418.1	1	pipe fitting m 12 p.1
65	0.007.1427.0	1	tube
66	0.002.8816.0	1	small plate
67	2.0112.007.2	1	screw m 6 p.1 x 20
68	2.1011.103.2	1	nut m 6 p.1
69	2.1470.002.2	1	lock washer 6

I9_38515_00_0-C-001

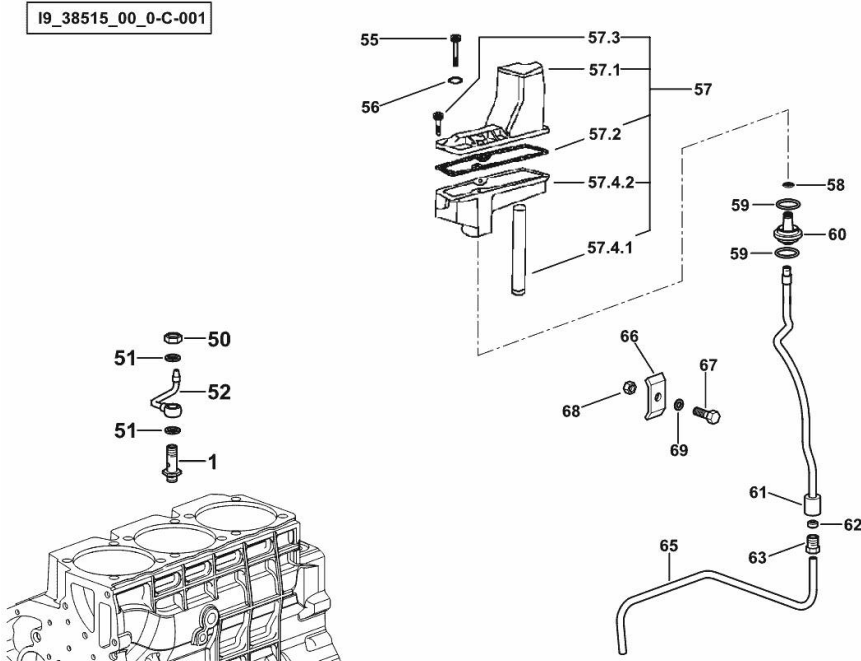

Thank you so much for reading.
Please click the “Buy Now!”
button below to download the
complete manual.



After you pay.

You can download the most
perfect and complete manual in
the world immediately.

Our support email:

ebooklibonline@outlook.com