

**ENGINE TYPE-APPROVAL DATA PLATE**

Fig.	P/n	QTY	Name
------	-----	-----	------

**Notes:**

[KRYPTON<sup>3</sup> 80 V - N] [KRYPTON<sup>3</sup> 80 V - M] [KRYPTON<sup>3</sup> 80 V - L] [KRYPTON<sup>3</sup> 80 V - C]

1	0.000.0000.1		cannot be supplied MADE BY TREVIGLIO ITALY
2	0.000.0000.1		cannot be supplied MADE AT RANIPET - INDIA

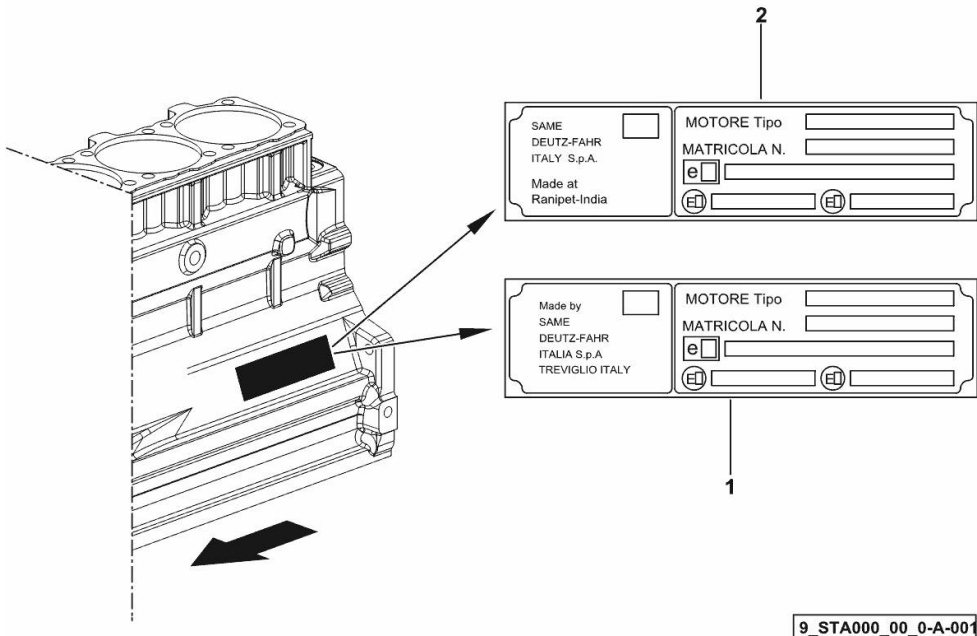

9\_STA000\_00\_0-A-001

**CRANKCASE**

Fig.	P/n	QTY	Name
------	-----	-----	------

**Notes:**

FOR ENGINES PRODUCED IN : TREVIGLIO ITALY [KRYPTON<sup>3</sup> 80 V - N] FOR ENGINES PRODUCED IN : TREVIGLIO ITALY [KRYPTON<sup>3</sup> 80 V - M] FOR ENGINES PRODUCED IN : TREVIGLIO ITALY [KRYPTON<sup>3</sup> 80 V - L] FOR ENGINES PRODUCED IN : TREVIGLIO ITALY [KRYPTON<sup>3</sup> 80 V - C]

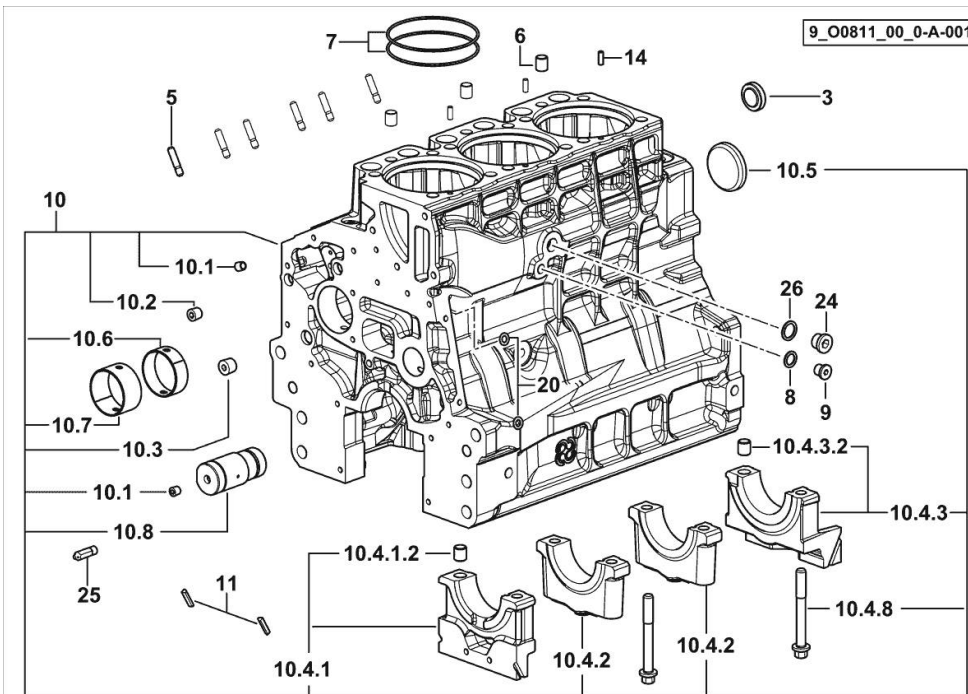

3	2.3199.312.2/20	1	plug m 35x1.5x9.5
5	2.0439.279.7	6	stud bolt m 8 p.1 x 25
6	2.1559.188.2	3	bush 11.4 x 14 x16
7	2.1539.259.0	6	special oil seal 107.62x2.62
8	2.1560.010.0	1	gasket 14.2 x 20
9	2.3199.292.0	1	plug 1/4" gas
10	0.014.9911.4/30	1	crankcase
10.1	2.3130.001.1	12	plug 1/8" gas
10.2	2.3130.002.1	4	plug 1/4" gas
10.3	2.3130.003.1	2	plug 3/8" gas
10.4.1	0.065.1112.3	1	support
10.4.1.2	2.1699.165.0	1	bush 12.3x15x16
10.4.2	0.065.1114.0/10	2	support
10.4.3	0.065.1116.3	1	support
10.4.3.2	2.1699.165.0	1	bush 12.3x15x16
10.4.8	0.065.1117.0	8	screw m 12 x 100
10.5	2.3179.012.0	1	plug 60
10.6	0.065.1140.0	3	special bushing 59X55X20
10.7	0.065.1141.0	1	special bushing 59X55X30
10.8	0.014.1340.0/10	1	pin mm 85
11	0.066.1152.0/10	4	gasket
14	2.1549.154.2	3	bush 4.8x5.8x16
20	2.1470.004.2	4	lock washer 8
24	2.3120.101.0	1	plug m 18 p.1.5
25	0.013.4946.0/10	1	sprayer nozzle
26	2.1560.014.0	1	washer 18.2 x 24

**CRANKCASE**

Fig.	P/n	QTY	Name
------	-----	-----	------

**Notes:**

FOR ENGINES PRODUCED IN : RANIPET - INDIA [KRYPTON<sup>3</sup> 80 V - N] FOR ENGINES PRODUCED IN :  
 RANIPET - INDIA [KRYPTON<sup>3</sup> 80 V - M] FOR ENGINES PRODUCED IN : RANIPET - INDIA [KRYPTON<sup>3</sup> 80 V  
 - L] FOR ENGINES PRODUCED IN : RANIPET - INDIA [KRYPTON<sup>3</sup> 80 V - C]

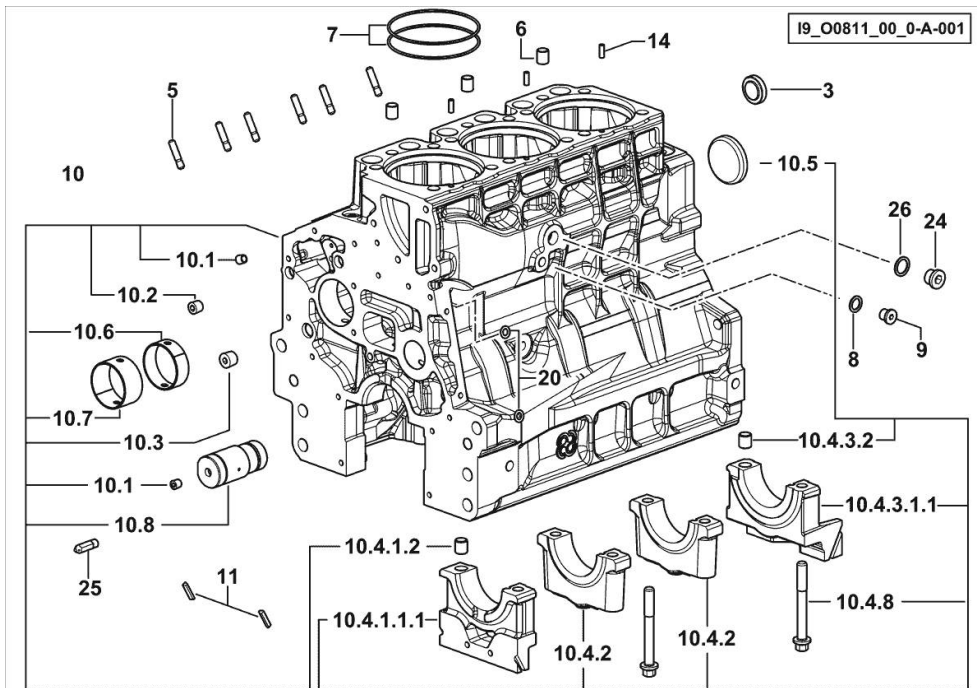

3	2.3199.312.2/20	1	plug m 35x1.5x9.5
5	2.0439.279.7	6	stud bolt m 8 p.1 x 25
6	2.1559.188.2	3	bush 11.4 x 14 x16
7	2.1539.259.0	6	special oil seal 107.62x2.62
8	2.1560.010.0	1	gasket 14.2 x 20
9	2.3199.292.0	1	plug 1/4" gas
10	0.014.9911.4/30	1	crankcase
10.1	2.3130.001.1	12	plug 1/8" gas
10.2	2.3130.002.1	4	plug 1/4" gas
10.3	2.3130.003.1	2	plug 3/8" gas
10.4.1.1.1	0.065.1112.7/10	1	support
10.4.1.2	2.1699.165.0	1	bush 12.3x15x16
10.4.2	0.065.1114.0/10	2	support
10.4.3.1.1	0.065.1116.7/10	1	support
10.4.3.2	2.1699.165.0	1	bush 12.3x15x16
10.4.8	0.065.1117.0	8	screw m 12 x 100
10.5	2.3179.012.0	1	plug 60
10.6	0.065.1140.0	3	special bushing 59X55X20
10.7	0.065.1141.0	1	special bushing 59X55X30
10.8	0.014.1340.0/10	1	pin mm 85
11	0.066.1152.0/10	4	gasket
14	2.1549.154.2	3	bush 4.8x5.8x16
20	2.1470.004.2	4	lock washer 8
24	2.3120.101.0	1	plug m 18 p.1.5
25	0.013.4946.0/10	1	sprayer nozzle
26	2.1560.014.0	1	washer 18.2 x 24

**MONOBLOC ENGINE-GEARBOX CONNECTING FLANGE**

Fig.	P/n	QTY	Name
------	-----	-----	------

**Notes:**

FOR ENGINES PRODUCED IN : TREVIGLIO ITALY [KRYPTON<sup>3</sup> 80 V - N] FOR ENGINES PRODUCED IN :  
 TREVIGLIO ITALY [KRYPTON<sup>3</sup> 80 V - M] FOR ENGINES PRODUCED IN : TREVIGLIO ITALY [KRYPTON<sup>3</sup>  
 80 V - L] FOR ENGINES PRODUCED IN : TREVIGLIO ITALY [KRYPTON<sup>3</sup> 80 V - C]

6	2.0439.250.7	1	stud bolt m 12 / m 10 x 30
7	0.011.9294.0/10	1	bush
30	2.0112.511.2	8	screw m 14 p.2 x 30
31	2.1651.912.0	2	cylindrical plug 12x28
32	2.1651.917.0	1	cylindrical plug 12x40
33	2.0432.257.7	1	stud bolt m 12 p.1.75 - 1.25 x 30
34	0.007.9745.0/10	1	flange

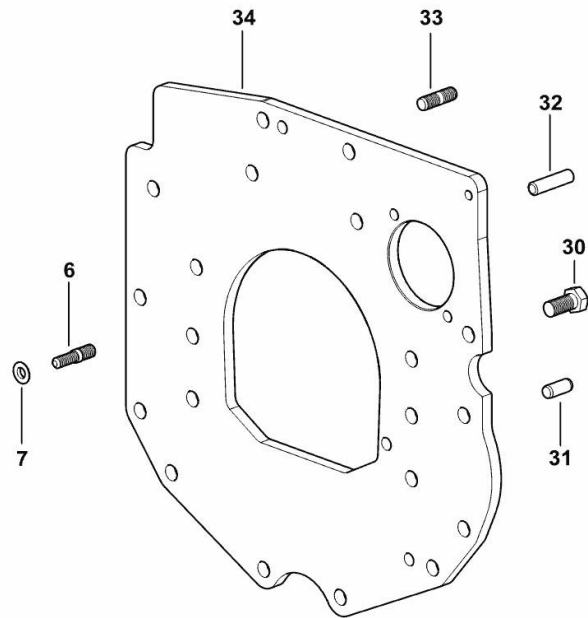

9\_33311\_02\_0-A-001

**MONOBLOC ENGINE-GEARBOX CONNECTING FLANGE**

Fig.	P/n	QTY	Name
------	-----	-----	------

**Notes:**

FOR ENGINES PRODUCED IN : RANIPET - INDIA [KRYPTON<sup>3</sup> 80 V - N] FOR ENGINES PRODUCED IN :  
 RANIPET - INDIA [KRYPTON<sup>3</sup> 80 V - M] FOR ENGINES PRODUCED IN : RANIPET - INDIA [KRYPTON<sup>3</sup> 80 V  
 - L] FOR ENGINES PRODUCED IN : RANIPET - INDIA [KRYPTON<sup>3</sup> 80 V - C]

6	2.0439.250.7	1	stud bolt m 12 / m 10 x 30
7	0.011.9294.0/10	1	bush
30	2.0112.511.2	8	screw m 14 p.2 x 30
31	2.1651.912.0	2	cylindrical plug 12x28
32	2.1651.917.0	1	cylindrical plug 12x40
33	2.0432.257.7	1	stud bolt m 12 p.1.75 - 1.25 x 30
34	0.007.9745.0/10	1	flange

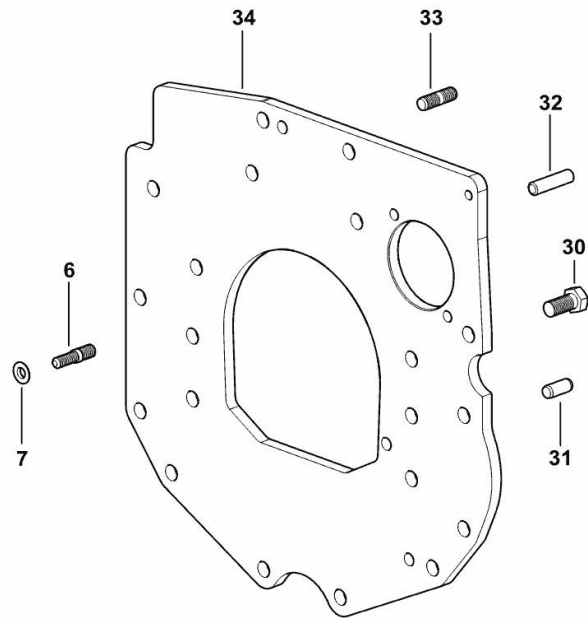

19\_33311\_02\_0-A-001

**CRANKSHAFT**

Fig.	P/n	QTY	Name
------	-----	-----	------

**Notes:**

FOR ENGINES PRODUCED IN : TREVIGLIO ITALY [KRYPTON<sup>3</sup> 80 V - N] 3012 <- FOR ENGINES PRODUCED IN : TREVIGLIO ITALY [KRYPTON<sup>3</sup> 80 V - M] 3012 <- FOR ENGINES PRODUCED IN : TREVIGLIO ITALY [KRYPTON<sup>3</sup> 80 V - L] 3012 <- FOR ENGINES PRODUCED IN : TREVIGLIO ITALY [KRYPTON<sup>3</sup> 80 V - C] 3012 <-

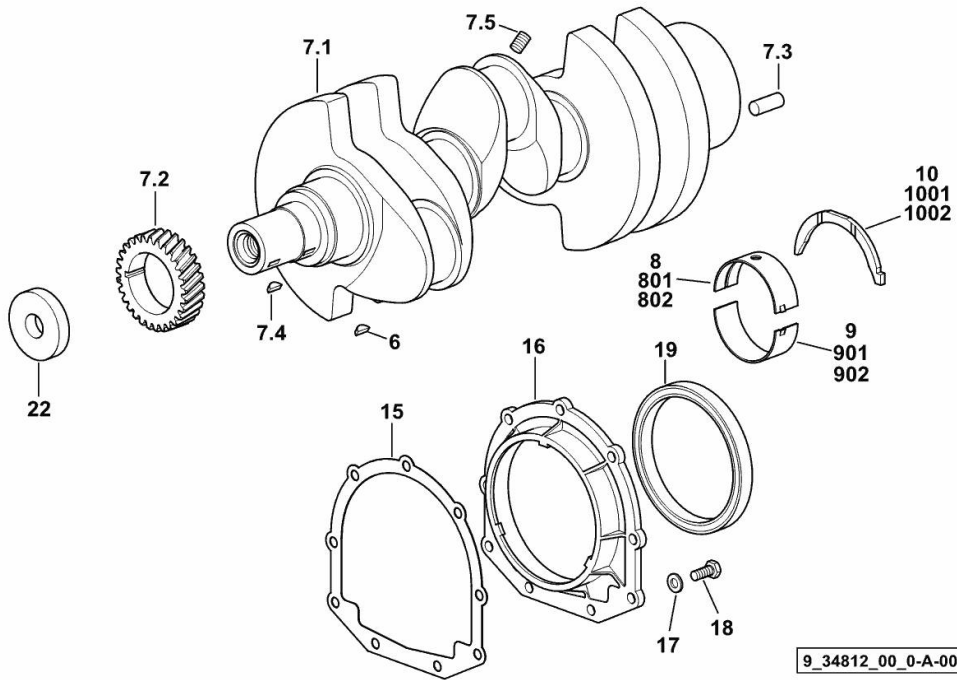

6	2.1720.006.0	1	key 4x6.5
7.1	0.007.1554.0/20	1	crankshaft
7.2	0.065.1323.0/30	1	gear Z = 29
7.3	2.1651.915.0	1	pin 12x35
7.4	2.1720.006.0	1	key 4x6.5
7.5	2.3130.001.1	3	plug 1/8" gas
8	0.065.1215.0/10	4	main half bushing STANDARD
9	0.065.1216.0/10	4	main half bushing STANDARD
10	0.065.1218.0	4	shim STANDARD
15	0.065.1254.0/20	1	gasket
16	0.007.1711.0/10	1	cover
17	2.1475.002.2	9	conical washer 8
18	2.0112.207.2	9	screw m 8 p 1.25 x 20
19	2.1529.073.0	1	special oil seal 110x130x13
22	2.1599.524.7	1	washer 21x60x12
801	0.065.1215.7		main half bushing - mm 0.25
802	0.065.1215.8		main half bushing - mm 0.50
901	0.065.1216.7		main half bushing - mm 0.25
902	0.065.1216.8		main half bushing - mm 0.50
1001	0.065.1218.7		shim + mm 0.10
1002	0.065.1218.8		shim + mm 0.15

9\_34812\_00\_0-A-001

**CRANKSHAFT**

Fig.	P/n	QTY	Name
------	-----	-----	------

**Notes:**

FOR ENGINES PRODUCED IN : TREVIGLIO ITALY [KRYPTON<sup>3</sup> 80 V - N] FOR ENGINES PRODUCED IN : TREVIGLIO ITALY [KRYPTON<sup>3</sup> 80 V - M] FOR ENGINES PRODUCED IN : TREVIGLIO ITALY [KRYPTON<sup>3</sup> 80 V - L] FOR ENGINES PRODUCED IN : TREVIGLIO ITALY [KRYPTON<sup>3</sup> 80 V - C]

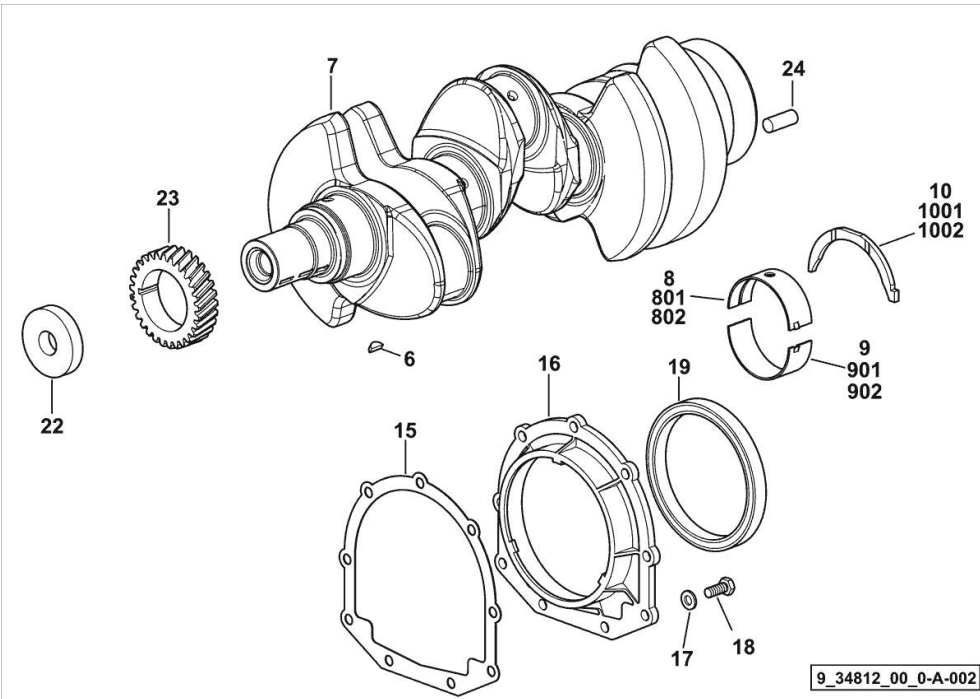

6	2.1720.006.0	1	key 4x6.5
7	0.019.2255.0/20	1	crankshaft
8	0.019.5455.0	4	main half bushing STANDARD
9	0.019.5456.0	4	main half bushing STANDARD
10	0.065.1218.0	4	shim STANDARD
15	0.065.1254.0/20	1	gasket
16	0.007.1711.0/10	1	cover
17	2.1475.002.2	9	conical washer 8
18	2.0112.207.2	9	screw m 8 p 1.25 x 20
19	2.1529.073.0	1	special oil seal 110x130x13
22	2.1599.524.7	1	washer 21x60x12
23	0.065.1323.0/30	1	gear Z = 29
24	2.1651.915.0	1	pin 12x35
801	0.065.1215.7	-	main half bushing - mm 0.25
802	0.065.1215.8	-	main half bushing - mm 0.50
901	0.065.1216.7	-	main half bushing - mm 0.25
902	0.065.1216.8	-	main half bushing - mm 0.50
1001	0.065.1218.7	-	shim + mm 0.10
1002	0.065.1218.8	-	shim + mm 0.15

9\_34812\_00\_0-A-002

**CRANKSHAFT**

Fig.	P/n	QTY	Name
------	-----	-----	------

**Notes:**

FOR ENGINES PRODUCED IN : RANIPET - INDIA [KRYPTON<sup>3</sup> 80 V - N] 3081 <- FOR ENGINES PRODUCED IN : RANIPET - INDIA [KRYPTON<sup>3</sup> 80 V - M] 3081 <- FOR ENGINES PRODUCED IN : RANIPET - INDIA [KRYPTON<sup>3</sup> 80 V - L] 3081 <- FOR ENGINES PRODUCED IN : RANIPET - INDIA [KRYPTON<sup>3</sup> 80 V - C] 3081 <-

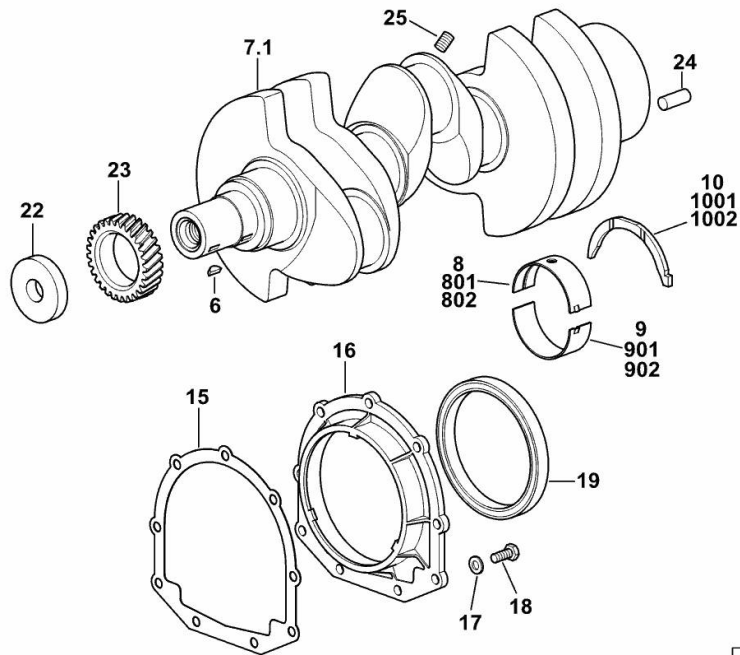

6	2.1720.006.0	1	key 4x6.5
7.1	0.007.1554.0/20	1	crankshaft
8	0.065.1215.0/10	4	main half bushing STANDARD
9	0.065.1216.0/10	4	main half bushing STANDARD
10	0.065.1218.0	4	shim STANDARD
15	0.065.1254.0/20	1	gasket
16	0.007.1711.0/10	1	cover
17	2.1475.002.2	9	conical washer 8
18	2.0112.207.2	9	screw m 8 p 1.25 x 20
19	2.1529.073.0	1	special oil seal 110x130x13
22	2.1599.524.7	1	washer 21x60x12
23	0.065.1323.0/30	1	gear Z = 29
24	2.1651.915.0	1	pin 12x35
25	2.3130.001.1	3	plug 1/8" gas
801	0.065.1215.7		main half bushing - mm 0.25
802	0.065.1215.8		main half bushing - mm 0.50
901	0.065.1216.7		main half bushing - mm 0.25
902	0.065.1216.8		main half bushing - mm 0.50
1001	0.065.1218.7		shim + mm 0.10
1002	0.065.1218.8		shim + mm 0.15

19\_O8312\_00\_0-A-001



**CRANKSHAFT**

Fig.	P/n	QTY	Name
------	-----	-----	------

**Notes:**

FOR ENGINES PRODUCED IN : RANIPET - INDIA [KRYPTON<sup>3</sup> 80 V - N] -> 3079 FOR ENGINES PRODUCED IN : RANIPET - INDIA [KRYPTON<sup>3</sup> 80 V - M] -> 3079 FOR ENGINES PRODUCED IN : RANIPET - INDIA [KRYPTON<sup>3</sup> 80 V - L] -> 3079 FOR ENGINES PRODUCED IN : RANIPET - INDIA [KRYPTON<sup>3</sup> 80 V - C] -> 3079

6	2.1720.006.0	1	key 4x6.5
7	0.019.2255.0/30	1	crankshaft
8	0.019.5455.0	4	main half bushing STANDARD
9	0.019.5456.0	4	main half bushing STANDARD
10	0.065.1218.0	4	shim STANDARD
15	0.065.1254.0/20	1	gasket
16	0.007.1711.0/10	1	cover
17	2.1475.002.2	9	conical washer 8
18	2.0112.207.2	9	screw m 8 p 1.25 x 20
19	2.1529.073.0	1	special oil seal 110x130x13
22	2.1599.524.7	1	washer 21x60x12
23	0.065.1323.0/30	1	gear Z = 29
24	2.1651.915.0	1	pin 12x35
1001	0.065.1218.7		shim + mm 0.10
1002	0.065.1218.8		shim + mm 0.15

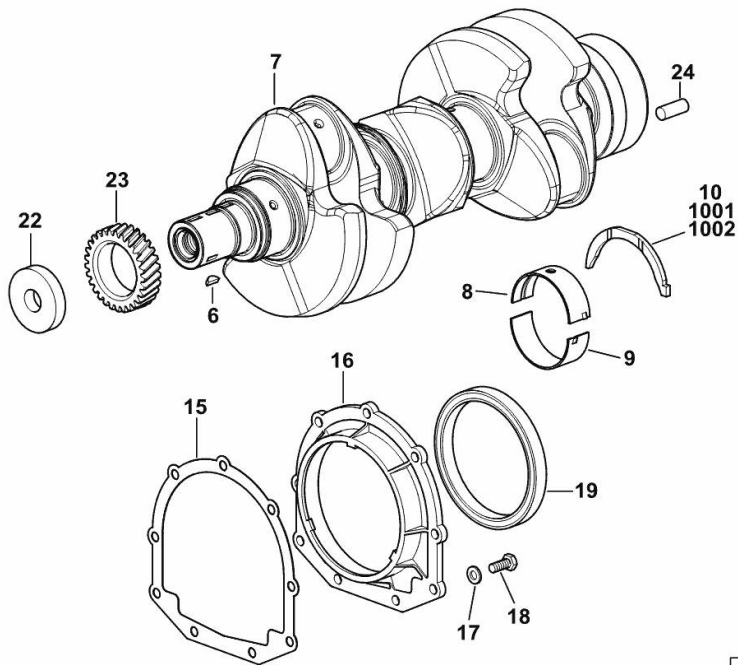

19\_O8312\_00\_0-A-002

**COOLANT PUMP AND ALTERNATOR DRIVEBELT**

Fig.	P/n	QTY	Name
------	-----	-----	------

Notes:  
[KRYPTON<sup>3</sup> 80 V - C] 2001 <-

1	2.4119.195.0	1	belt PV-K5 ( mm 17.4x1250 )
---	--------------	---	-----------------------------

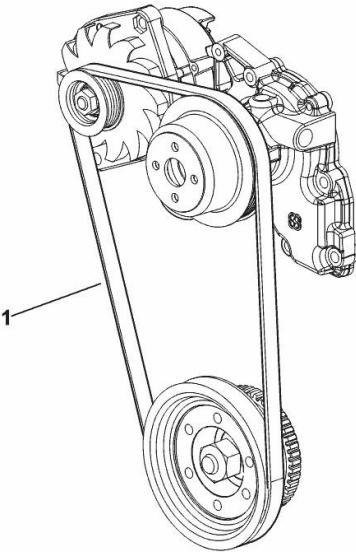

9\_N2517\_09\_0-A-001

**COOLANT PUMP AND ALTERNATOR DRIVEBELT**

Fig.	P/n	QTY	Name
------	-----	-----	------

**Notes:**  
[KRYPTON<sup>3</sup> 80 V - N] [KRYPTON<sup>3</sup> 80 V - M] [KRYPTON<sup>3</sup> 80 V - L] [KRYPTON<sup>3</sup> 80 V - C] -> 2002

1	2.4119.187.0	1	belt PV-K5 (mm 1230)
---	--------------	---	----------------------

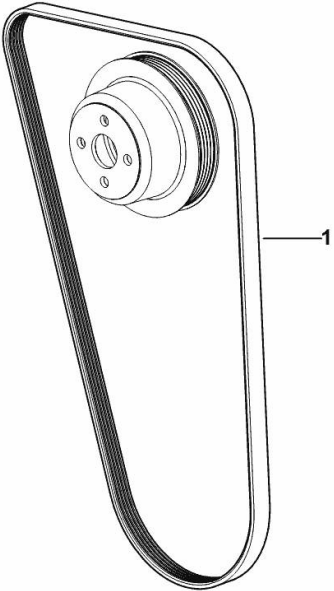

9\_O6817\_09\_0-A-001

**ENGINE FLYWHEEL**

Fig.	P/n	QTY	Name
------	-----	-----	------

**Notes:**

FOR ENGINES PRODUCED IN : TREVIGLIO ITALY [KRYPTON<sup>3</sup> 80 V - N] FOR ENGINES PRODUCED IN :  
 TREVIGLIO ITALY [KRYPTON<sup>3</sup> 80 V - M] FOR ENGINES PRODUCED IN : TREVIGLIO ITALY [KRYPTON<sup>3</sup>  
 80 V - L] FOR ENGINES PRODUCED IN : TREVIGLIO ITALY [KRYPTON<sup>3</sup> 80 V - C]

1	0.007.9652.3/10	1	flywheel
1.2	0.069.1242.0	1	crown wheel Z = 121
2	2.0119.174.0/10	6	screw m 12 p.1.25x45
3	2.2041.008.0	1	ball bearing 20x47x14

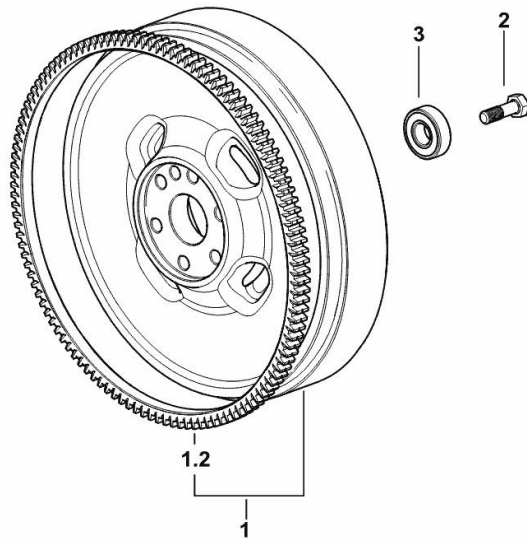

9\_34812\_03\_0-A-001

**ENGINE FLYWHEEL**

Fig.	P/n	QTY	Name
------	-----	-----	------

**Notes:**

FOR ENGINES PRODUCED IN : RANIPET - INDIA [KRYPTON<sup>3</sup> 80 V - N] FOR ENGINES PRODUCED IN :  
 RANIPET - INDIA [KRYPTON<sup>3</sup> 80 V - M] FOR ENGINES PRODUCED IN : RANIPET - INDIA [KRYPTON<sup>3</sup> 80 V  
 - L] FOR ENGINES PRODUCED IN : RANIPET - INDIA [KRYPTON<sup>3</sup> 80 V - C]

1	0.007.9652.3/10	1	flywheel
1.2	0.069.1242.0	1	crown wheel Z = 121
2	2.0119.174.0/10	6	screw m 12 p.1.25x45
3	2.2041.008.0	1	ball bearing 20x47x14

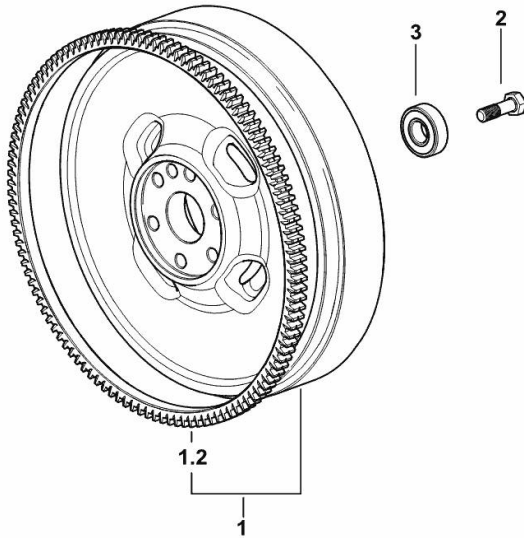

I9\_34812\_03\_0-A-001

**CRANKSHAFT PULLEY**

Fig.	P/n	QTY	Name
------	-----	-----	------

**Notes:**

FOR ENGINES PRODUCED IN : TREVIGLIO ITALY [KRYPTON<sup>3</sup> 80 V - N] FOR ENGINES PRODUCED IN : TREVIGLIO ITALY [KRYPTON<sup>3</sup> 80 V - M] FOR ENGINES PRODUCED IN : TREVIGLIO ITALY [KRYPTON<sup>3</sup> 80 V - L] FOR ENGINES PRODUCED IN : TREVIGLIO ITALY [KRYPTON<sup>3</sup> 80 V - C]

3	0.015.6659.0	1	pulley OUTSIDE DIAMETER 167 mm
5	0.085.1248.0/20	1	hub
6	2.0399.144.7/10	1	screw m 20 p.1.5x51
8	2.1720.006.0	1	key 4x6.5

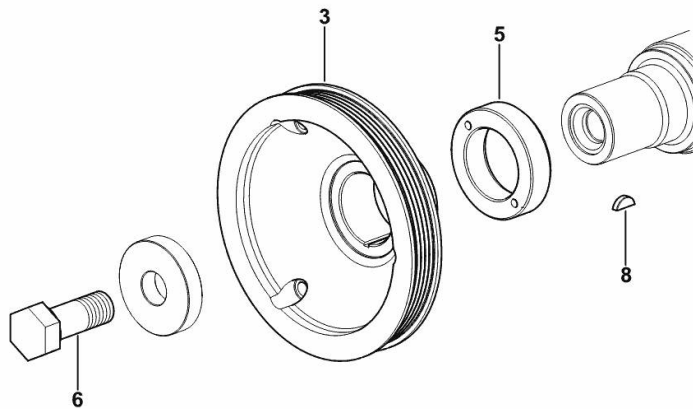

9\_M5012\_03\_0-A-001

**CRANKSHAFT PULLEY**

Fig.	P/n	QTY	Name
------	-----	-----	------

**Notes:**

FOR ENGINES PRODUCED IN : RANIPET - INDIA [KRYPTON<sup>3</sup> 80 V - N] FOR ENGINES PRODUCED IN :  
 RANIPET - INDIA [KRYPTON<sup>3</sup> 80 V - M] FOR ENGINES PRODUCED IN : RANIPET - INDIA [KRYPTON<sup>3</sup> 80 V  
 - L] FOR ENGINES PRODUCED IN : RANIPET - INDIA [KRYPTON<sup>3</sup> 80 V - C]

3	0.015.6659.0	1	pulley
5	0.085.1248.0/20	1	hub
6	2.0399.144.7/10	1	screw m 20 p.1.5x51
8	2.1720.006.0	1	key 4x6.5

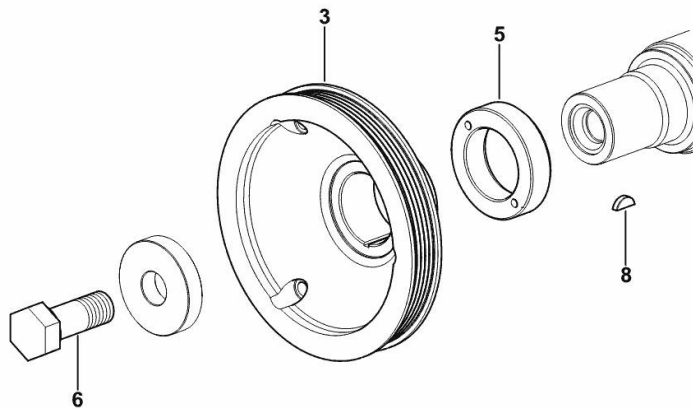

19\_M5012\_03\_0-A-001

Thank you so much for reading.  
Please click the “Buy Now!”  
button below to download the  
complete manual.



After you pay.

You can download the most  
perfect and complete manual in  
the world immediately.

Our support email:

[ebooklibonline@outlook.com](mailto:ebooklibonline@outlook.com)