

CRANKCASE

Fig.	P/n	QTY	Name
------	-----	-----	------

Notes:

[LASER 170 -> 10001]

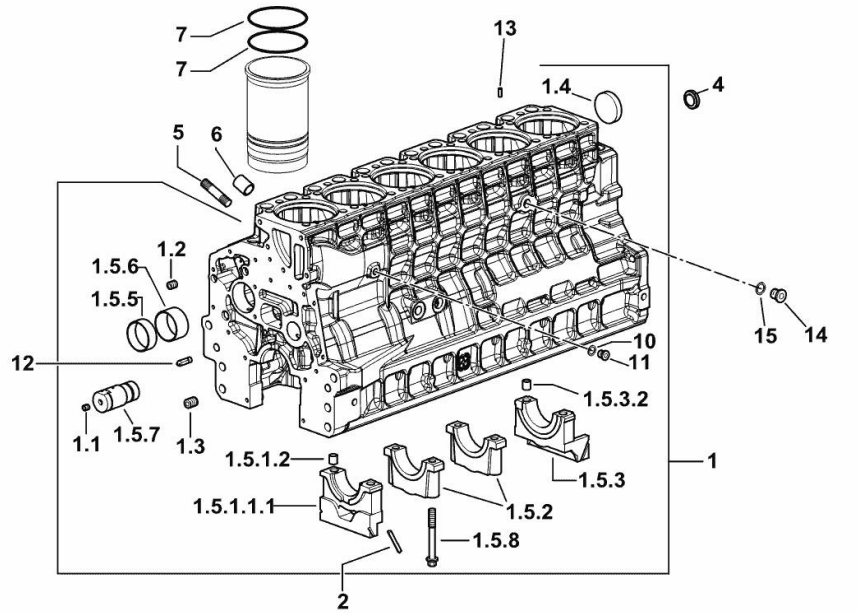

9_N6311_00_0-A-001

1	0.015.3558.4/10	1	crankcase
1.1	2.3130.001.1	20	plug 1/8" gas
1.2	2.3130.002.1	4	plug 1/4" gas
1.3	2.3130.003.1	6	plug 3/8" gas
1.4	2.3179.012.0	1	plug 60
1.5.1.1.1	0.065.1112.7/10	1	support
1.5.1.2	2.1699.165.0	1	bush 12.3x15x16
1.5.2	0.065.1114.0/10	5	support
1.5.3	0.007.0848.3/20	1	support
1.5.3.2	2.1699.165.0	1	bush 12.3x15x16
1.5.5	0.065.1140.0	6	special bushing 59X55X20
1.5.6	0.065.1141.0	1	special bushing 59X55X30
1.5.7	0.014.1340.0/10	1	pin mm 85
1.5.8	0.065.1117.0	14	screw m 12 x 100
2	0.066.1152.0/10	4	gasket
4	2.3199.312.2/20	1	plug m 35x1.5x9.5
5	2.0439.279.7	12	stud bolt m 8 p.1 x 25
6	2.1559.188.2	6	bush 11.4 x 14 x16
7	2.1539.259.0	12	special oil seal 107.62x2.62
10	2.1560.010.0	1	gasket 14.2 x 20
11	2.3199.292.0	1	plug 1/4" gas
12	0.013.4946.0/10	1	sprayer nozzle
13	2.1549.154.2	6	bush 4.8x5.8x16
14	2.3120.101.0	1	plug m 18 p.1.5
15	2.1560.014.0	1	washer 18.2 x 24

MONOBLOC ENGINE-GEARBOX CONNECTING FLANGE

Fig.	P/n	QTY	Name
------	-----	-----	------

Notes:

[LASER 170 -> 10001]

1	2.3131.003.2	1	plug m 16 p.1.5
6	2.0439.250.7	1	stud bolt m 12 / m 10 x 30
7	0.011.9294.0/10	1	bush
8	0.007.0809.0/20	1	flange
9	2.0112.513.2	11	screw m 14 p.2 x 35
13	2.1651.911.0	2	cylindrical plug
15	2.0432.257.7	1	stud bolt m 12 p.1.75 - 1.25 x 30
16	2.0312.520.2	2	screw m 14 p.2x70

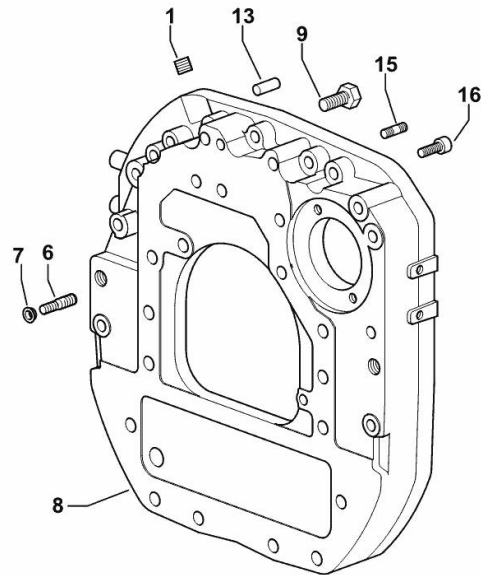

9_N0411_01_0-A-001

ENGINE OIL AND TURBO PRESSURE SWITCH UNION

Fig.	P/n	QTY	Name
------	-----	-----	------

Notes:

[LASER 170 -> 10001]

23	2.3339.673.0/10	1	pipe fitting
26	2.3110.403.1	1	plug m 14 p.1.5x12
27	2.1560.010.0	1	gasket 14.2 x 20
28	2.1019.129.2/10	1	nut m 18 p.1.5x12
29	2.1533.038.0	1	oil seal 15.45x2.62

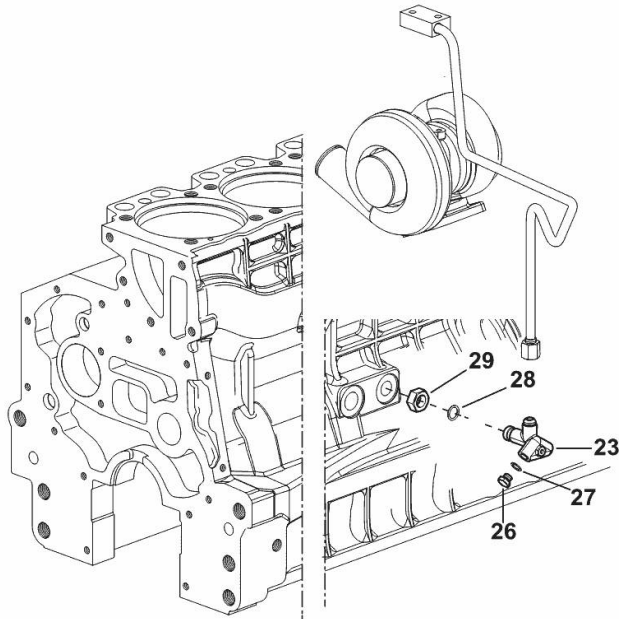

9_N6315_03_0-B-001

ENGINE LIFTING BRACKET

Fig.	P/n	QTY	Name
------	-----	-----	------

Notes:

[LASER 170 -> 10001]

31	2.1310.004.2	2	flat washer 8.4x17
32	2.0112.207.2	2	screw m 8 p 1.25 x 20
36	0.008.9433.0	1	bracket

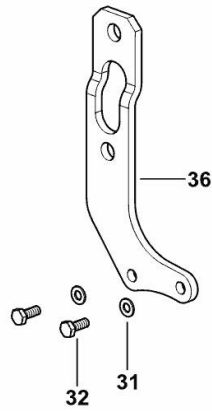

9_N6318_01_0-C-001

ENGINE FLYWHEEL

Fig.	P/n	QTY	Name
------	-----	-----	------

Notes:

[LASER 170 -> 10001]

1	0.078.1241.3	1	flywheel
1.2	0.065.1242.0	1	crown wheel Z = 123
2	0.288.3625.0	1	flange
3	2.0139.023.2	6	screw
4	2.1651.915.0	1	pin 12x35

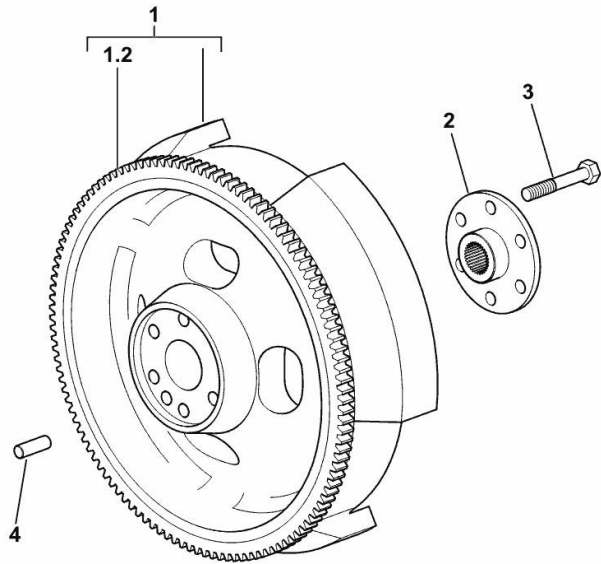

9_N0412_01_0-A-001

CRANKSHAFT

Fig.	P/n	QTY	Name
------	-----	-----	------

Notes:

[LASER 170 -> 10001]

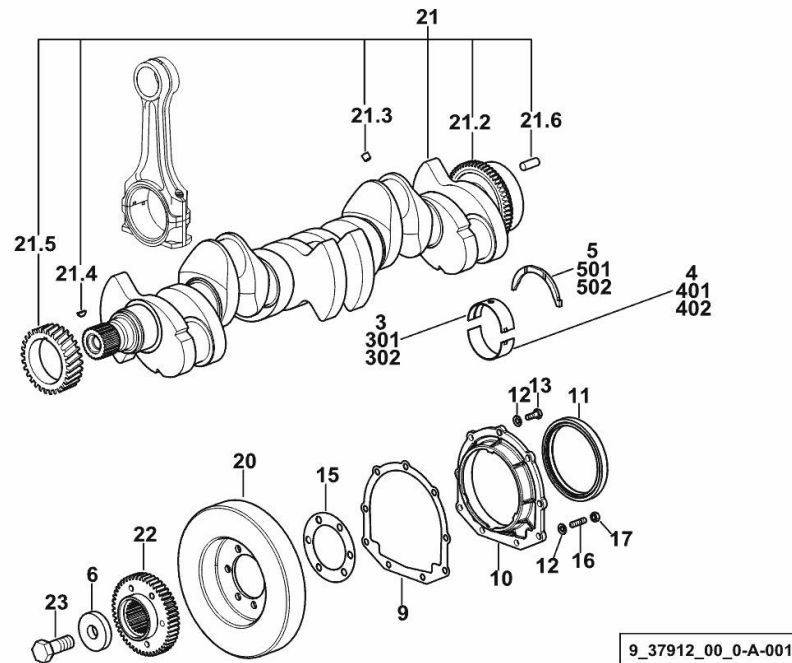

3	0.065.1215.0/10	7	main half bushing STANDARD
4	0.065.1216.0/10	7	main half bushing STANDARD
5	0.065.1218.0	4	shim STANDARD
6	2.1599.524.7	1	washer 21x60x12
9	0.065.1254.0/20	1	gasket
10	0.007.0851.0/10	1	cover
11	2.1529.073.0	1	special oil seal 110x130x13
12	2.1475.002.2	9	conical washer 8
13	2.0112.207.2	7	screw m 8 p 1.25 x 20
15	2.1589.137.0	2	shoulder ring 71x110x1
16	2.0432.003.7	2	stud bolt m 8 p.1.25 / p.1 x 20
17	2.1011.105.2	2	nut m 8 p.1.25
20	0.009.3704.3	1	antivibration pulley
21	0.010.4320.3/30	1	crankshaft
21.2	0.007.0855.0/10	1	gear
21.3	2.3130.001.1	6	plug 1/8" gas
21.4	2.1720.006.0	1	key 4x6.5
21.5	0.007.1188.0/30	1	gear Z = 29
21.6	2.1651.915.0	1	pin 12x35
22	0.011.2206.0/20	1	hub
23	2.0399.144.7/10	1	screw m 20 p.1.5x51
301	0.065.1215.7		main half bushing - mm 0.25
302	0.065.1215.8		main half bushing - mm 0.50
401	0.065.1216.7		main half bushing - mm 0.25
402	0.065.1216.8		main half bushing - mm 0.50
501	0.065.1218.7		shim + mm 0.10
502	0.065.1218.8		shim + mm 0.15

CRANKSHAFT PULLEY

Fig.	P/n	QTY	Name
------	-----	-----	------

Notes:

[LASER 170 -> 10001]

1	0.007.0962.0/30	1	pulley
2	2.0112.322.2	6	screw m 10 p.1.5x65
3	2.1470.006.2	6	lock washer 10

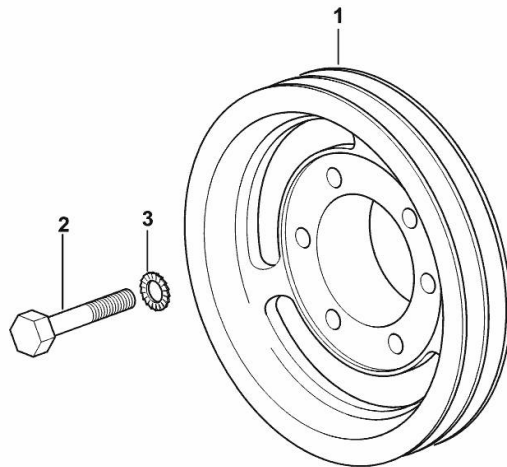

9_33712_01_0-A-001

COOLANT PUMP AND ALTERNATOR DRIVEBELT

Fig.	P/n	QTY	Name
------	-----	-----	------

Notes:

[LASER 170 -> 10001]

1	2.4119.099.0	2	belt AV 13x1437 mm
---	--------------	---	--------------------

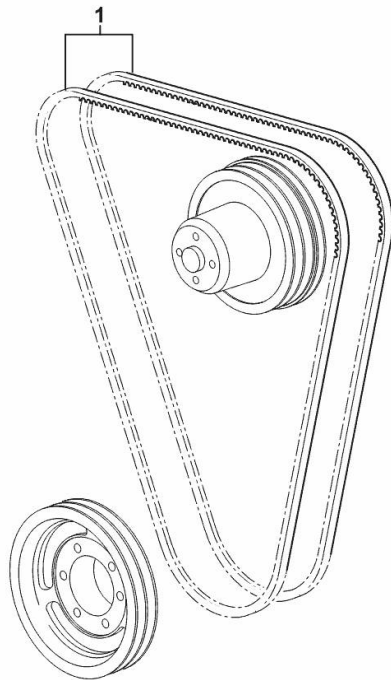

9_33717_01_0-A-001

COOLANT PUMP AND ALTERNATOR DRIVEBELT

Fig.	P/n	QTY	Name
------	-----	-----	------

Notes:

- FOR MODELS WITH COMPRESSOR [LASER 170 -> 10001]

1	0.007.0967.0	2	belt AV 12.7x1470 mm
2	2.4119.134.0	1	belt AV 10x794 mm

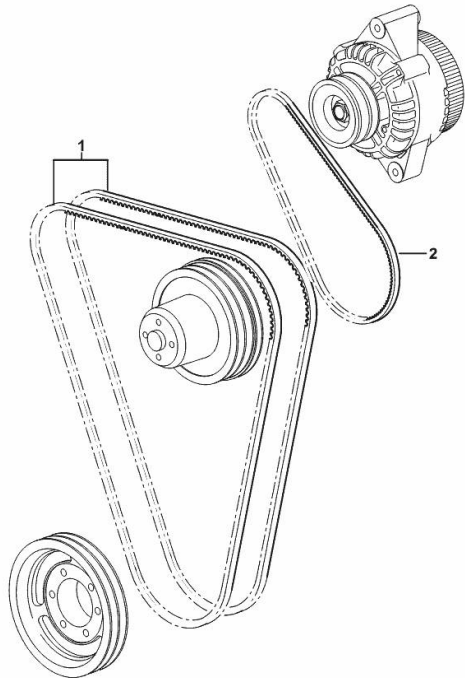

9_M9917_02_0-A-001

CYLINDER - PISTON - CONNECTING ROD

Fig.	P/n	QTY	Name
------	-----	-----	------

Notes:

[LASER 170 -> 10001]

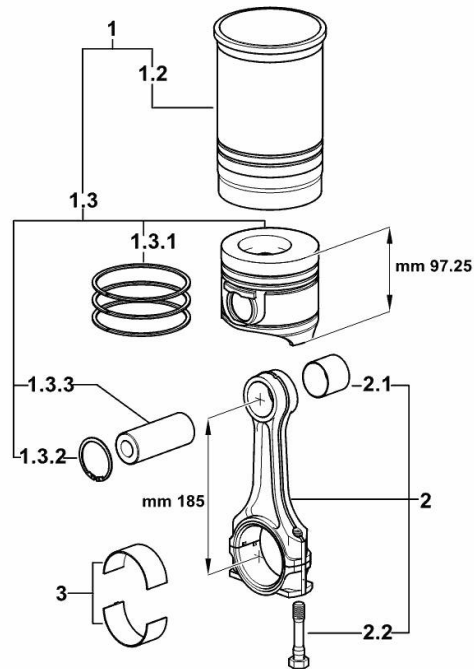

9_Q7512_01_M-A-001

1	0.O55.0065.A	6	cyl. piston assembly "A" - CLASS A
1	0.O55.0065.B	6	cyl. piston assembly "B" - CLASS B
1.2	0.A12.2675.0	1	engine cylinder "A" - CLASS A
1.2	0.B12.2675.0	1	engine cylinder "B" - CLASS B
1.3	0.O55.0060.A	1	complete piston "A" - CLASS A
1.3	0.O55.0060.B	1	complete piston "B" - CLASS B
1.3.1	0.338.0052.6/20	1	piston ring set
1.3.2	2.1411.014.1	2	circlip 35
1.3.3	0.078.1236.0	1	piston pin Ø 18 / Ø 35 / L = mm 86
2	0.014.5175.3	6	engine connecting rod
2.1	2.1559.255.0	1	special bushing 34.60x39.130x34.65
2.2	2.0399.213.0	2	screw m 12 p.1.25x61.5
3	0.065.1225.0	12	con.rod half bushing STANDARD - A = 28.75 -> 29.00
3	0.065.1225.7	12	con.rod half bushing - mm 0.25
3	0.065.1225.8	12	con.rod half bushing - mm 0.50

CAMSHAFT

Fig.	P/n	QTY	Name
------	-----	-----	------

Notes:

[LASER 170 -> 10001]

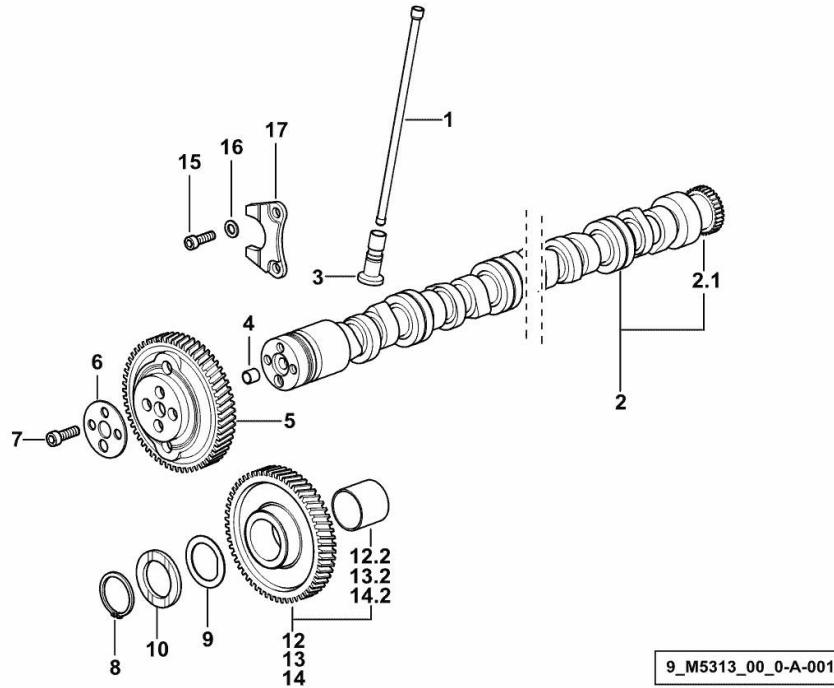

1	0.065.1331.2	12	rod
2	0.013.1647.3/10	1	camshaft
2.1	0.065.1324.0/10	1	gear Z = 32
3	0.065.1330.0	12	tappets
4	2.1559.398.0	1	bushing 10.5x13x12
5	0.013.5017.0	1	gear z=58
6	0.065.1350.0	1	small disc
7	2.0132.207.2	4	screw m 10 p.1 x 25
8	2.1410.016.1	1	circlip 40
9	0.065.1352.0	1	shim
10	0.018.2233.0	2	shoulder ring
12	0.007.1177.3/20	0.5	gear z = 57 - WITH RED IDENTIFICATION STAMP
12.2	2.1559.185.0/10	1	bushing
13	0.007.1178.3/20	0.5	gear z = 57 - WITH YELLOW IDENTIFICATION STAMP
13.2	2.1559.185.0/10	1	bushing
14	0.007.1179.3/20		gear z = 57 - WITH GREEN IDENTIFICATION STAMP
14.2	2.1559.185.0/10	1	bushing
15	2.0312.205.2	2	screw
16	2.1480.014.1	2	washer 8
17	0.065.1353.0	1	small plate

GUARD PLATE

Fig.	P/n	QTY	Name
------	-----	-----	------

Notes:

[LASER 170 -> 10001]

1	0.007.1262.3/50	1	guard
2	0.007.1271.0/10	1	small column m 8 p.1.25 / L = mm 60
3	0.007.1272.0/10	2	small column m 8 p.1.25 / L = mm 50
5	2.1310.004.2	3	flat washer 8.4x17
7	2.0112.203.2	3	screw m 8 p.1.25 x 12

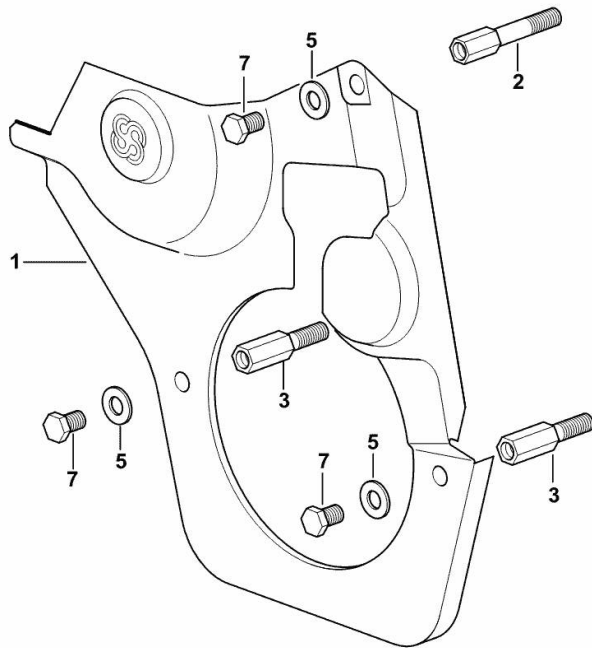

9_33011_02_0-A-001

TIMING CASE

Fig.	P/n	QTY	Name
------	-----	-----	------

Notes:

[LASER 170 -> 10001]

1	0.013.4981.0	1	guard
11	0.065.1150.0/30	1	gasket
12	2.0432.003.7	2	stud bolt m 8 p.1.25 / p.1 x 20
13	2.0312.219.2	4	screw m 8 p.1.25x65
14	2.1480.014.1	15	washer 8
15	2.1470.004.2	4	lock washer 8
16	2.1011.405.2	2	nut m 8 p.1
17	2.1529.167.0	1	oil seal
18	2.0312.214.2	3	screw m 8 p.1.25 x 40
19	2.0312.208.2	8	screw m 8 p.1.25 x 25

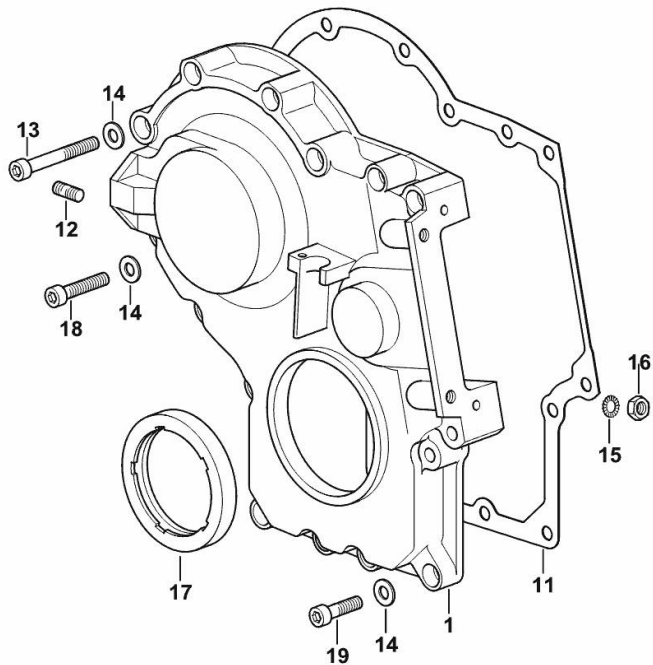

9_M3711_01_0-A-001

CASING COVER

Fig.	P/n	QTY	Name
------	-----	-----	------

Notes:

[LASER 170 -> 10001]

30	0.065.1152.0	1	gasket
31	0.065.1151.0	1	cover
32	2.0112.205.2	2	screw m 8 p.1.25 x 16
34	2.0432.005.7	2	stud bolt m 8 p.1.5 / p.1 x 25

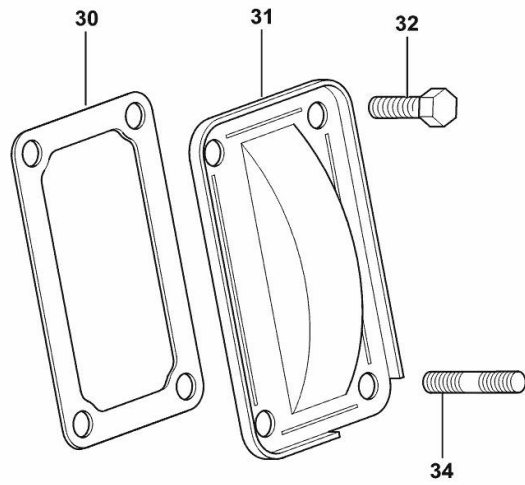

9_33011_04_0-A-001

Section: B0 - ENGINE
CYLINDER HEAD

Fig.	P/n	QTY	Name
------	-----	-----	------

Notes:

[LASER 170 -> 10001]

1.1	0.017.0868.3	1	engine head
1.1.2	0.078.1426.0	1	valve seat
1.1.3	0.066.1427.0	1	valve seat
1.1.4	0.007.1779.0/20	2	valve guide
1.1.5	0.012.9984.0/20	1	bush
1.1.6	2.3170.012.2	2	expansion plug Ø 30
1.2	0.007.1147.0/10	1	exhaust valve mm 39.1 / Ø mm 9
1.3	0.007.1146.0/10	1	inlet valve mm 43.63 / Ø mm 9
1.4	0.066.1425.0	2	cup
1.5	0.074.1423.0	4	conical valve cotter
1.6	2.4019.287.0	2	spring
1.7	2.1519.117.0	2	special oil seal
1.8	2.0432.161.7	1	stud bolt m 10 p.1.5 / p.1.25 x 40
1.9	2.0432.163.7	2	stud bolt m 10 p.1.5 / p.1.25 x 45
2	2.0432.011.7	6	stud bolt m 8 p.1.25 / p.1 x 40
3	2.0432.005.7	6	stud bolt m 8 p.1.5 / p.1 x 25
9	0.012.2673.0	24	screw m 14 p.2x141
10.2	0.021.1434.0	2	screw
10.10.3	2.1011.405.2	2	nut m 8 p.1
10.10.4	0.066.1432.3	2	rocker arm
10.10.4.2	2.1559.021.0/40	1	bushing 15x19x22
10.10.5	2.1410.055.7	2	circlip 19
10.10.6.1	0.066.1431.0	1	pin
10.10.6.2	0.066.1430.0/10	1	support
10.10.7	2.1599.432.0	2	shoulder ring
15	2.1011.421.2	12	nut m 10 p.1.25
19	2.1532.507.0	6	oil seal 17x3.53
20	0.015.9190.0	0.5	head gasket mm 1.2
21	0.015.9191.0	5	head gasket mm 1.4
22	0.015.9192.0	0.5	head gasket mm 1.6
32	0.009.3877.0/10	2	tappet gasket
33	2.0399.288.2/10	6	screw m 8x36x46
34	2.1532.018.0	6	oil seal 9.19 x 2.62
40	0.014.0696.0	2	cover

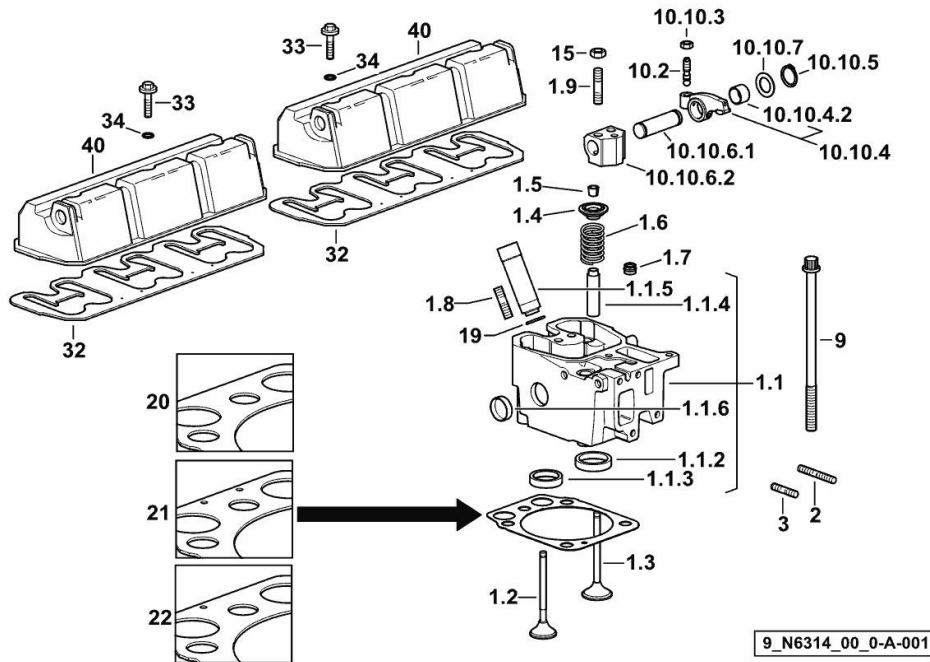

Thank you so much for reading.
Please click the “Buy Now!”
button below to download the
complete manual.



After you pay.

You can download the most
perfect and complete manual in
the world immediately.

Our support email:

ebooklibonline@outlook.com