

CRANKCASE

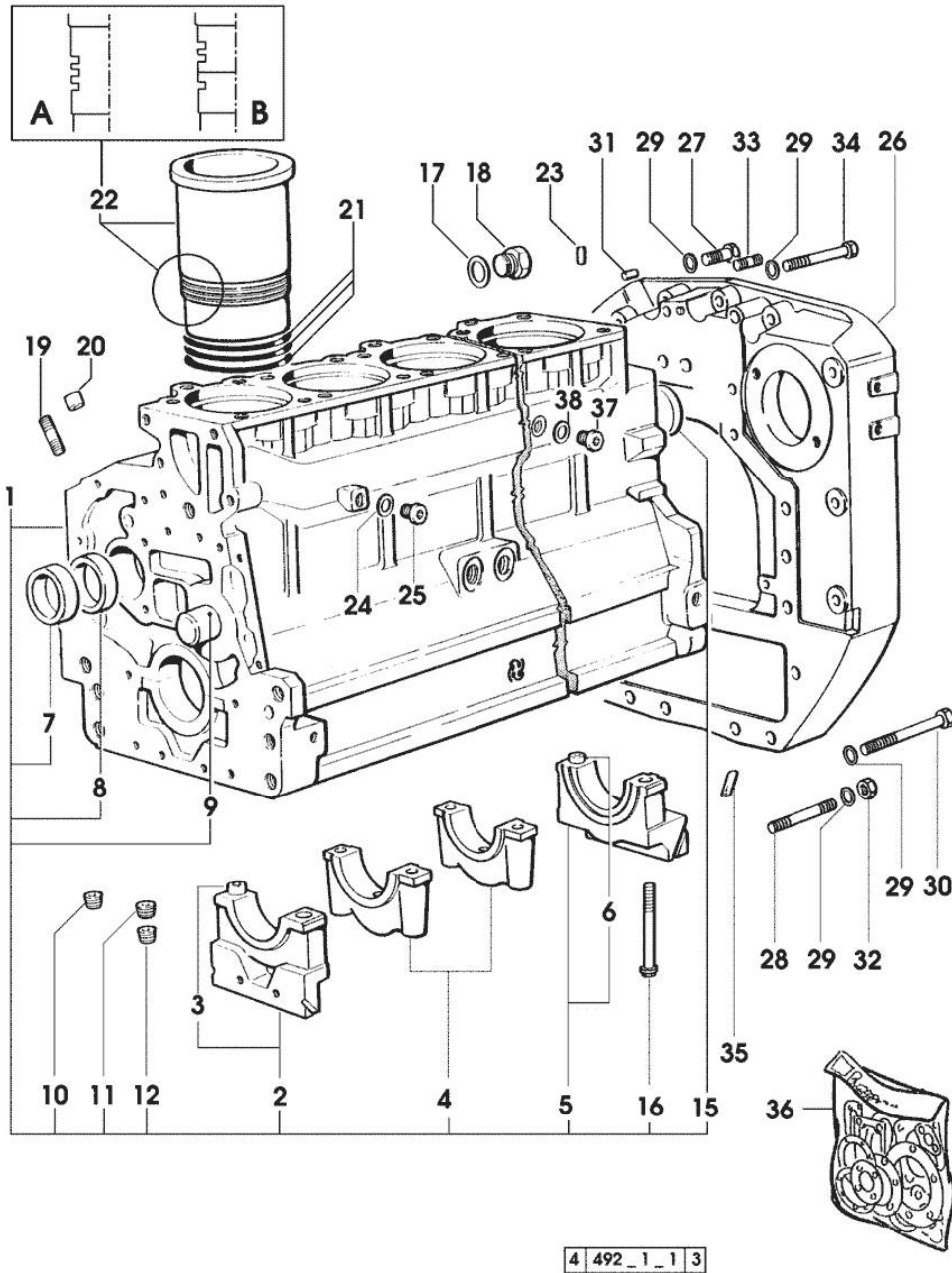
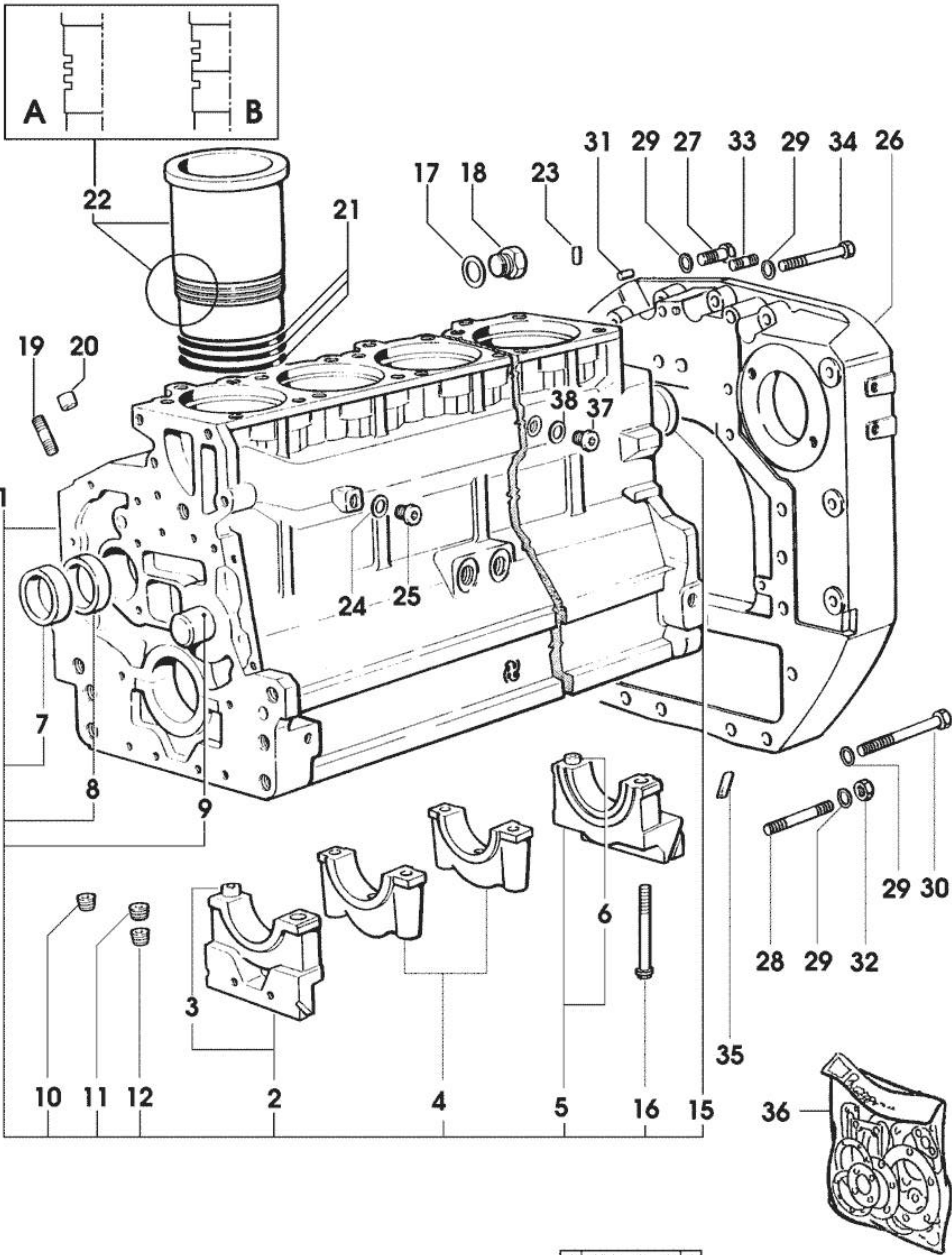

Fig.	P/n	QTY	Name
Notes:			
[H-6190 MASTER]			
1	0.007.1102.6/20	1	crankcase * 2195 <= X H-6165 * 2523 <= X H-6190 - N.6 011.0183.0/10 - N.12 2.1539.193.0
2	0.065.1112.7	1	support
3	2.1699.165.0	1	bush 12.3x15x16
4	0.065.1114.0/10	5	support
5	0.007.0848.3/10	1	support
6	2.1699.165.0	1	bush 12.3x15x16
7	0.065.1141.0	1	special bushing 59X55X30
8	0.065.1140.0	6	special bushing 59X55X20
9	0.066.1151.0	1	pin
10	2.3130.001.1	14	plug 1/8" gas
11	2.3130.002.1	2	plug 1/4" gas
12	2.3130.003.1	8	plug 3/8" gas
15	2.3179.012.0	1	plug 60
16	0.065.1117.0	14	screw m 12 x 100
17	2.1539.047.0	1	special oil seal 26.7x1.78
18	2.3199.405.2	1	plug m 28 p.1.5
19	2.0432.003.7	18	stud bolt m 8 p.1.25 / p.1 x 20
20	2.1559.188.2	6	bush 11.4 x 14 x16
21	2.1519.096.0/20	18	special oil seal 107.67x1.78 2195 <= X H-6165 2523 <= X H-6190
21	2.1539.193.0	12	special oil seal 107.62x2.62 => 2196 X H-6165 => 2524 X H-6190
22	0.009.7500.0/10	6	engine cylinder = A 1471 <= X H-6165 1592 <= X H-6190
22	0.011.0183.0/20	6	engine cylinder => 2196 X H-6165 => 2524 X H-6190
22	0.011.0582.0	6	engine cylinder = B => 1472 - 2195 <= X H-6165 => 1593 - 2523 <= X H-6190
23	2.1549.154.2	6	bush 4.8x5.8x16
24	2.1560.010.0	1	gasket 14.2 x 20
25	2.3199.292.0	1	plug 1/4" gas

Section: ENGINE
CRANKCASE

Fig.	P/n	QTY	Name
26	0.007.0809.0/20	1	flange * 1102 <- X MASTER H-6165 * 1110 <- X MASTER H-6190 - N.4 - 2.1699.448.0
27	2.0112.513.2	11	screw m 14 p.2 x 35
28	2.0432.328.7	4	stud bolt m 14 p.2-1.5x130
29	2.1470.008.2	19	lock washer 14
30	2.0112.534.2	2	screw m 14 p.2x125
31	2.1653.911.0	2	cylindrical plug 12x25
32	2.1011.108.2	4	nut m 14 p.2
33	2.0432.255.7	2	stud bolt m 12 p.1.75-1.25x25
34	2.0312.520.1	2	screw m 14 p.2x70
35	0.066.1152.0/10	4	gasket
36	0.337.0050.6		gasket set
37	2.3120.101.0	1	plug m 18 p.1.5 => 2196 X H-6165 => 2524 X H-6190
38	2.1560.014.0	1	washer 18.2 x 24



4 492_1_1 3

Section: ENGINE
TIMING CASE

Fig.	P/n	QTY	Name
------	-----	-----	------

Notes:
[H-6190 MASTER]

1	0.007.1262.3/50	1	guard
2	0.007.1271.0/10	1	small column m 8 p.1.25 / L = mm 60
3	0.007.1272.0/10	2	small column m 8 p.1.25 / L = mm 50
5	2.1310.004.2	3	flat washer 8.4x17
7	2.0112.205.2	3	screw m 8 p.1.25 x 16

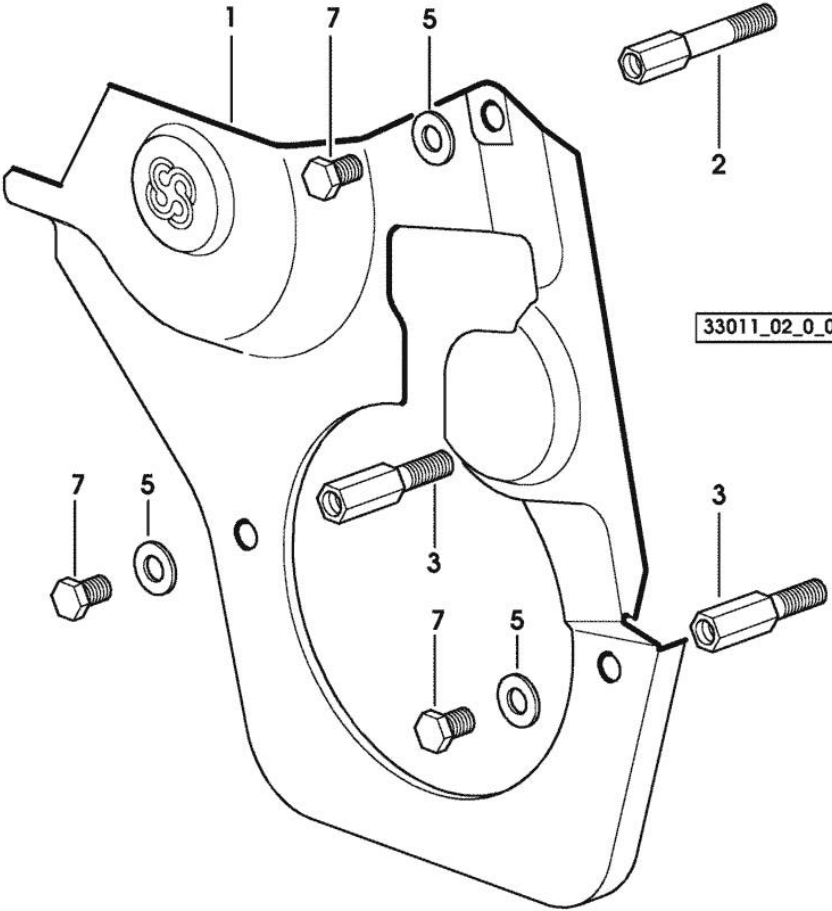

Section: ENGINE
TIMING CASE

Fig.	P/n	QTY	Name
------	-----	-----	------

Notes:
[H-6190 MASTER]

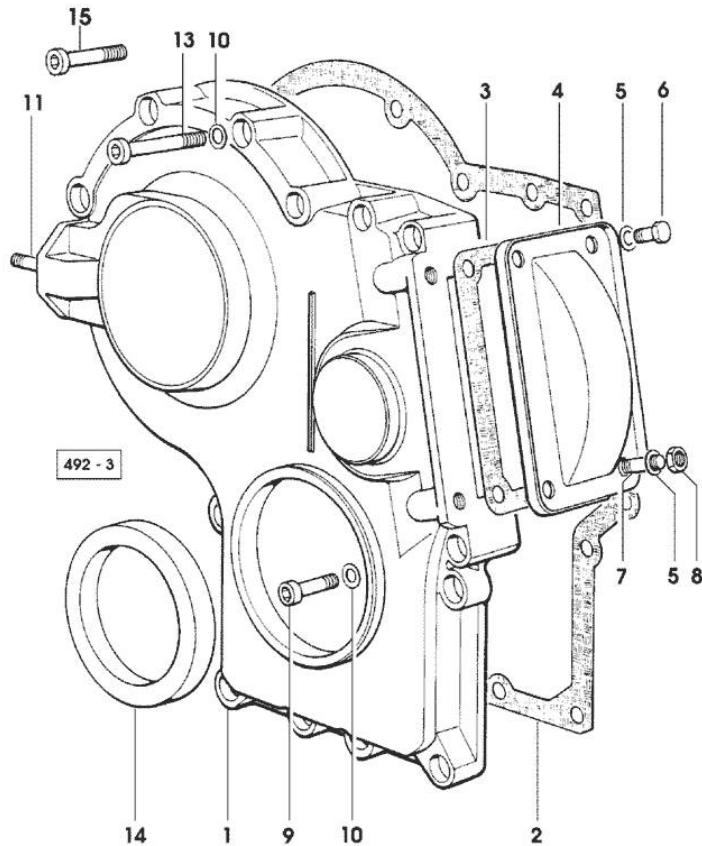

1	0.065.1132.0/60	1	guard
2	0.065.1150.0/30	1	gasket
3	0.065.1152.0	1	gasket
4	0.065.1151.0	1	cover
5	2.1470.004.2	4	lock washer 8
6	2.0112.205.2	2	screw m 8 p.1.25 x 16
7	2.0432.003.7	2	stud bolt m 8 p.1.25 / p.1 x 20
8	2.1011.405.2	2	nut m 8 p.1
9	2.0312.214.1	3	screw m 8 p.1.25 x 40
10	2.1480.014.1	15	washer 8
11	2.0432.003.7	2	stud bolt m 8 p.1.25 / p.1 x 20
13	2.0312.219.2	4	screw m 8 p.1.25x65
14	2.1529.141.0	1	special oil seal
15	2.0312.208.2	8	screw m 8 p.1.25 x 25

Section: ENGINE

CRANKSHAFT

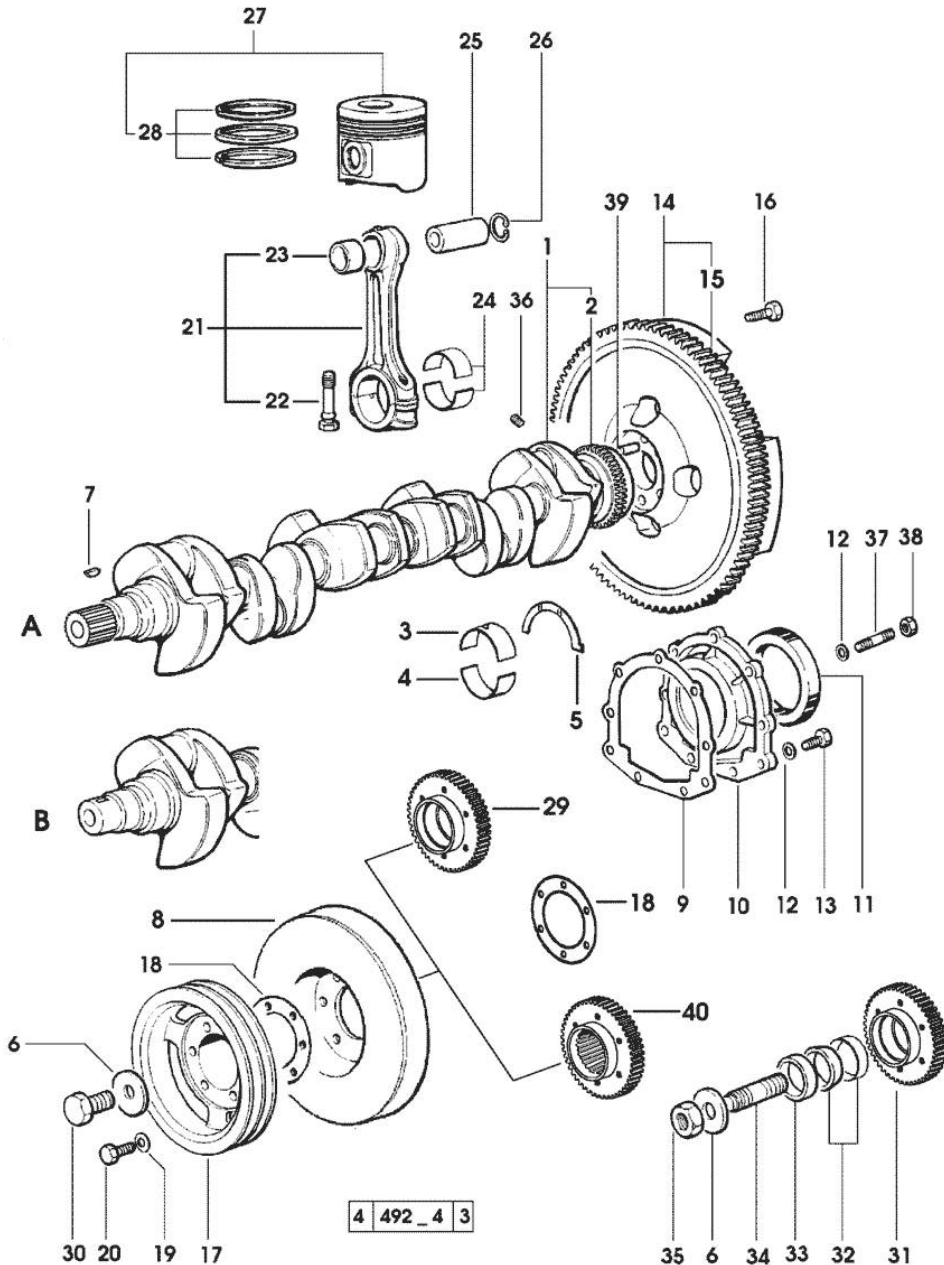

Fig.	P/n	QTY	Name
Notes:			
[H-6190 MASTER]			
1	0.010.4320.3/20	1	crankshaft (...) <= " B " * N.1 011.2206.0/10
2	0.007.0855.0	1	gear
3	0.065.1215.0	7	main half bushing STANDARD
3	0.065.1215.7		main half bushing - mm 0.25
3	0.065.1215.8		main half bushing - mm 0.50
4	0.065.1216.0	7	main half bushing
4	0.065.1216.7		main half bushing - mm 0.25
4	0.065.1216.8		main half bushing - mm 0.50
5	0.065.1218.0	4	shim STANDARD
5	0.065.1218.7		shim + mm 0.10
5	0.065.1218.8		shim + mm 0.15
6	2.1599.524.7	1	washer 21x60x12
7	2.1720.006.0	1	key 4x6.5
8	0.007.1010.3	1	antivibration pulley
9	0.065.1254.0/20	1	gasket
10	0.007.0851.0/10	1	cover
11	2.1529.073.0	1	special oil seal 110x130x13
12	2.1474.009.2	9	spring washer 8
13	2.0112.207.2	7	screw m 8 p 1.25 x 20
14	0.007.0655.3/20	1	flywheel
15	0.065.1242.0	1	crown wheel Z = 123
16	2.0119.174.0	6	screw m 12 p.1.25x45
17	0.007.0962.0/20	1	pulley
18	2.1589.137.0		shoulder ring 71x110x1
19	2.1470.006.2	6	lock washer 10
20	2.0112.322.2	6	screw m 10 p.1.5x65
21	0.007.1395.3/20	6	engine connecting rod
22	2.0399.213.0	12	screw m 12 p.1.25x61.5
23	2.1559.255.0	6	special bushing 34.60x39.130x34.65
24	0.065.1225.0	12	con.rod half bushing STANDARD - A = 28.75 -> 29.00
24	0.065.1225.7		con.rod half bushing - mm 0.25
24	0.065.1225.8		con.rod half bushing - mm 0.50
25	0.038.1236.0/10	6	piston pin Ø 18 / Ø 35 / L = mm 90
26	2.1411.014.1	12	circlip 35
27	0.340.0060.6/10	6	complete piston
27	0.383.0060.6	6	complete piston - EXPORT U.S.A.
28	0.338.0052.6		piston ring set
29	0.011.2140.0/10	1	hub

CRANKSHAFT

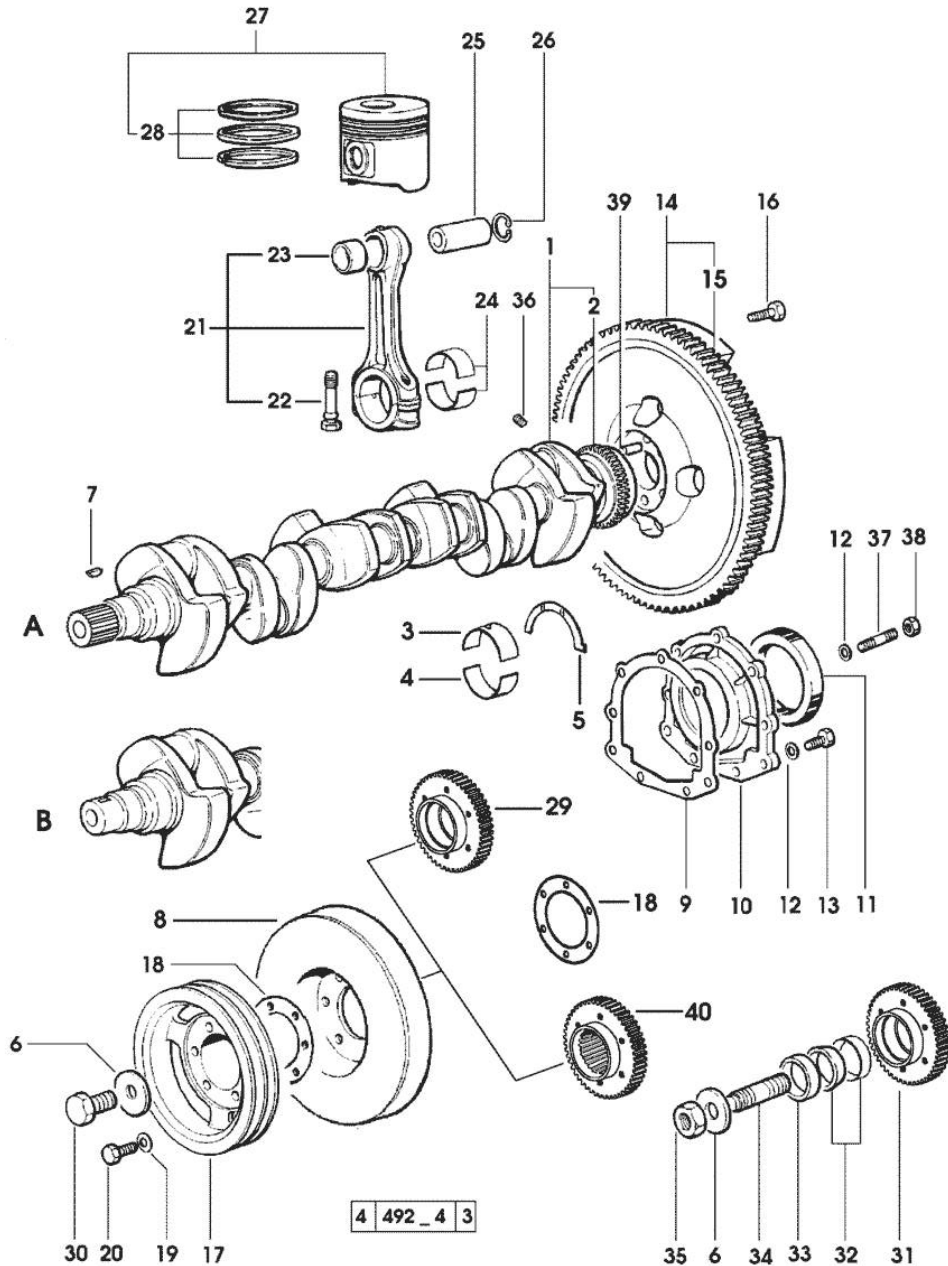

Fig.	P/n	QTY	Name
30	2.0399.144.7/10	1	- X B (...) <= screw m 20 p.1.5x51
31	0.011.2141.0/10	1	hub - FOR P.T.O. FRONT - X B (...) <=
32	0.035.1263.0	2	ring - X B (...) <=
33	2.1579.949.0	1	ring 50.2x56.8x8 - X B (...) <=
34	2.0439.195.7	1	stud bolt m 20 p.1.5x80 - X B (...) <=
35	2.1019.094.7	1	nut m 20 p.1.5 - X B (...) <=
36	2.3130.001.1	6	plug 1/8" gas
37	2.0432.003.7	2	stud bolt m 8 p.1.25 / p.1 x 20
38	2.1011.105.2	2	nut m 8 p.1.25
39	2.1652.915.0	1	cylindrical plug 12x35
40	0.011.2206.0/10	1	hub - X A => (...)

Section: ENGINE

CAMSHAFT

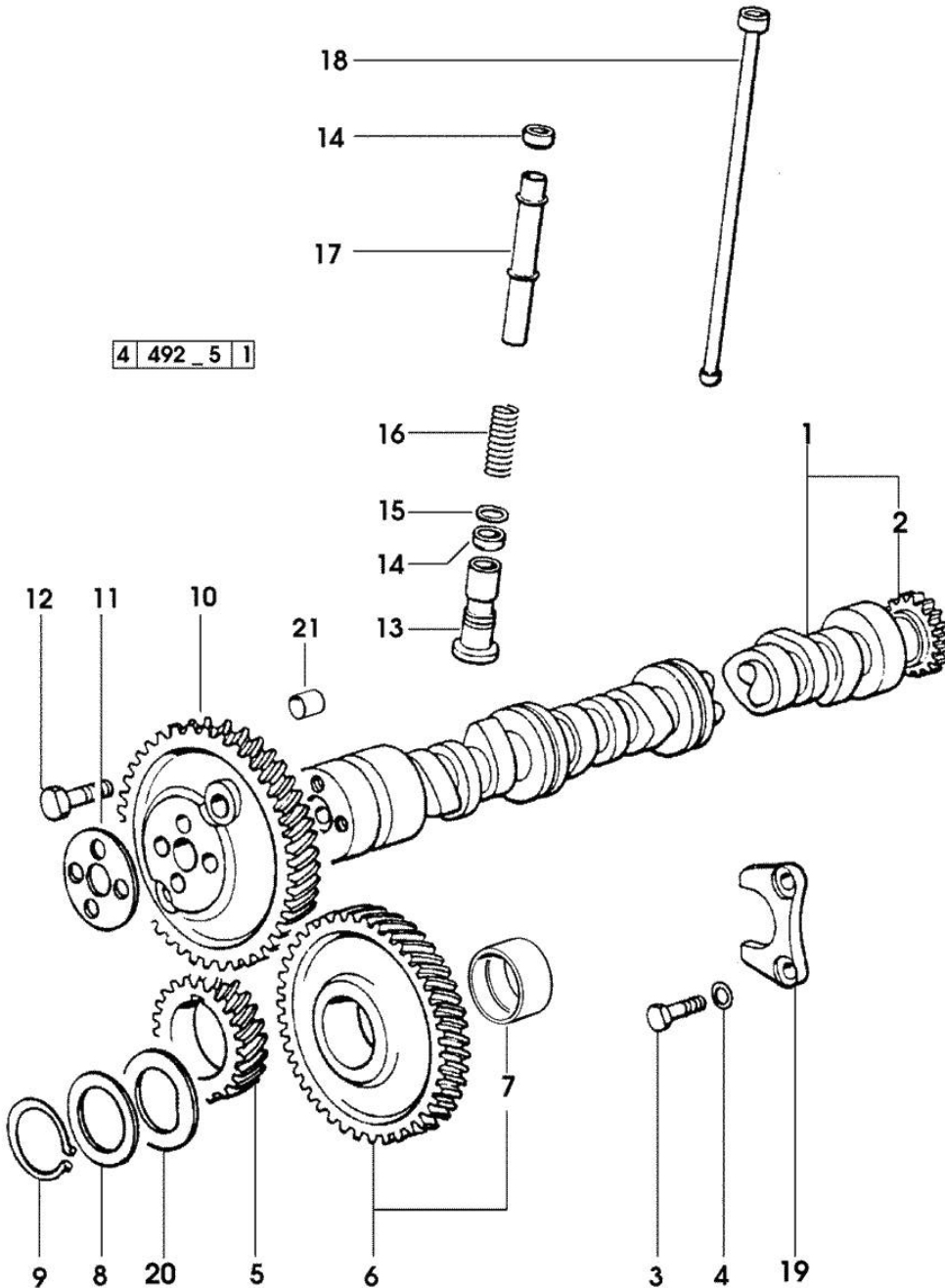

Fig.	P/n	QTY	Name
------	-----	-----	------

Notes:
[H-6190 MASTER]

1	0.010.4968.3/10	1	camshaft - EXPORT U.S.A.
1	0.075.1310.3/30	1	camshaft
2	0.065.1324.0/10	1	gear Z = 32
3	2.0312.206.2	2	screw m 8 p 1.25 x 20
4	2.1480.014.1	2	washer 8
5	0.007.1188.0/20	1	gear Z = 29
6	0.007.1177.3/10	1	gear z = 57 - WITH RED IDENTIFICATION STAMP
6	0.007.1178.3/10		gear z = 57 - WITH YELLOW IDENTIFICATION STAMP
6	0.007.1179.3/10		gear z = 57 - WITH GREEN IDENTIFICATION STAMP
7	2.1559.185.0/10	2	bushing
8	0.065.1352.0	1	shim
9	2.1410.016.1	1	circlip 40
10	0.065.1354.0/20	1	gear z=58
11	0.065.1350.0	1	small disc
12	2.0132.207.2	4	screw m 10 p.1 x 25
13	0.065.1330.0	12	tappets
14	2.1569.114.0/10	24	gasket 14x18.5x8
15	2.1599.437.0	12	shoulder ring
16	2.4019.300.1/10	12	spring 18.5x52x2
17	0.065.1332.0	12	sleeve
18	0.065.1331.2	12	rod
19	0.065.1353.0	1	small plate
20	0.065.1351.0	2	shoulder ring
21	2.1559.398.0	1	bushing 10.5x13x12

Section: ENGINE
CYLINDER HEAD

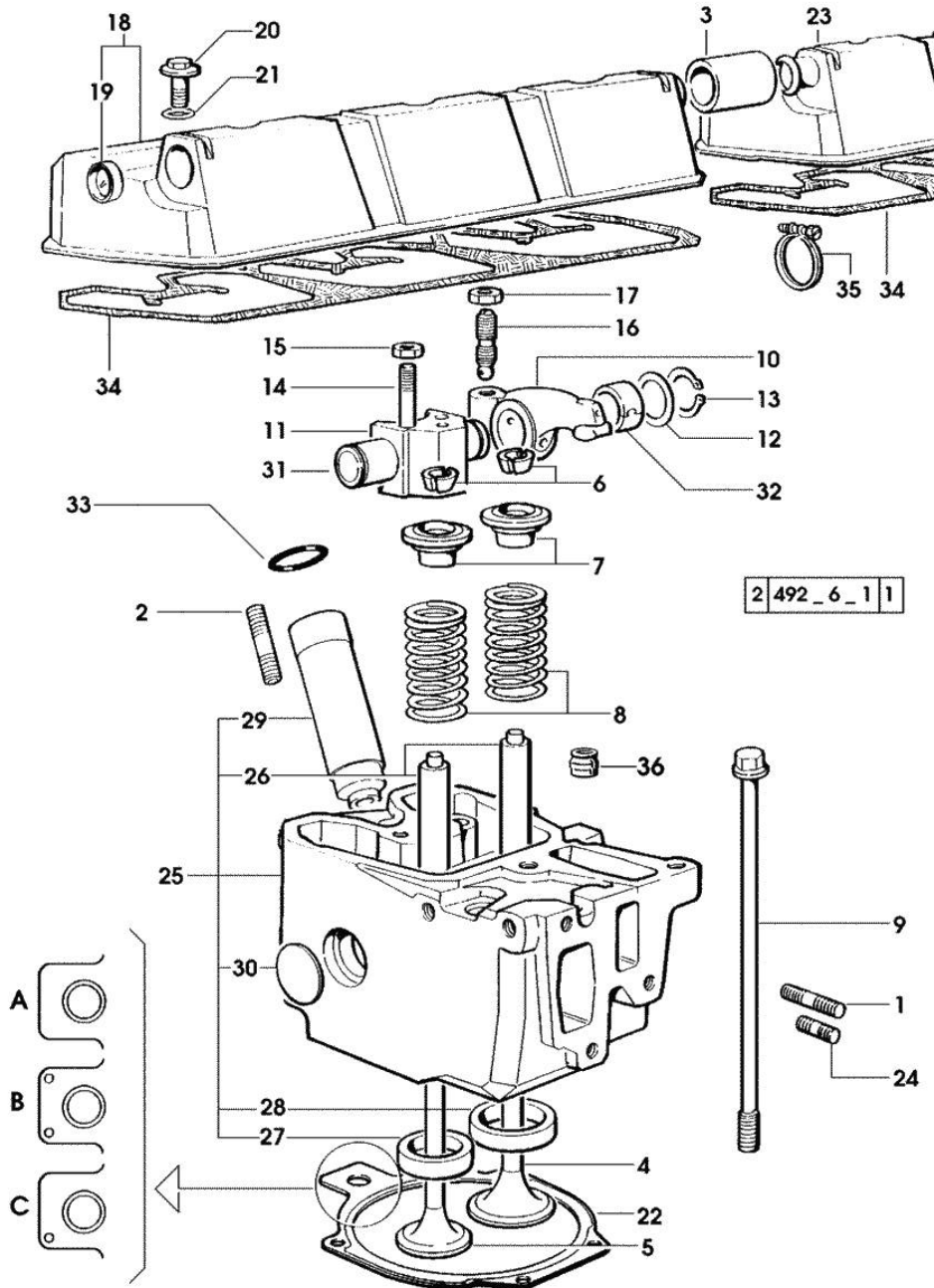

Fig.	P/n	QTY	Name
------	-----	-----	------

Notes:
[H-6190 MASTER]

1	2.0432.011.7	6	stud bolt m 8 p.1.25 / p.1 x 40
2	2.0432.161.7	6	stud bolt m 10 p.1.5 / p.1.25 x 40
3	0.075.1452.0/10	1	sleeve
4	0.007.1146.0/10	6	inlet valve mm 43.63 / Ø mm 9
5	0.007.1147.0/10	6	exhaust valve mm 39.1 / Ø mm 9
6	0.074.1423.0	24	conical valve cotter
7	0.066.1425.0	12	cup
8	2.4019.287.0	12	spring
9	0.066.1443.0/10	24	screw
10	0.066.1432.0	6	rocker arm
11	0.066.1430.0/10	6	support
12	2.1599.432.0	12	shoulder ring
13	2.1410.055.1	12	circlip 19
14	2.0432.163.7	6	stud bolt m 10 p.1.5 / p.1.25 x 45
15	2.1011.421.2	12	nut m 10 p.1.25
16	0.021.1434.0	12	screw
17	2.1011.405.2	12	nut m 8 p.1
18	0.078.1440.3	1	cover
19	2.3171.008.4	1	plug 20
20	2.0399.130.2	6	screw m 8 x 30
21	2.1532.035.0	6	oil seal 14x1.78
22	0.078.1451.0/40	6	head gasket -A-
22	0.078.1452.0/30	6	head gasket -B-
22	0.078.1453.0/40	6	head gasket -C-
23	0.078.1450.3	1	cover
24	2.0432.005.7	6	stud bolt m 8 p.1.5 / p.1 x 25
25	0.007.1360.3/60	6	head
26	0.007.1779.0/10	12	valve guide
27	0.066.1427.0	6	valve seat
28	0.078.1426.0	6	valve seat
29	0.010.6041.0	6	bush
30	2.3170.012.1	12	expansion plug 30
31	0.066.1431.0	6	pin
32	2.1559.021.0/40	6	bushing 15x19x22
33	2.1530.051.0	6	oil seal 20.22x3.53
34	0.009.3877.0/10	2	tappet gasket
35	2.6859.091.0	2	clamp
36	2.1519.117.0	12	special oil seal

Section: ENGINE
LUBRICATION

Fig.	P/n	QTY	Name
------	-----	-----	------

Notes:
[H-6190 MASTER]

1	2.0312.206.2	2	screw m 8 p 1.25 x 20
2	2.1480.014.1	2	washer 8
3	0.041.1135.4	1	plug 1" gas
4	2.1569.072.0	1	gasket 32 x 39.5 x 2
5	0.065.1565.0/10	1	pipe union
6	2.1539.042.0	1	special oil seal 47.35x1.78
7	0.065.1567.0/10	1	filter
8	2.3339.307.0	2	pipe fitting m 22 p.1.5-3/4"
9	0.007.0849.0/10	1	gasket
14	0.080.1513.2/10	1	dipstick
15	2.1539.065.0	2	special oil seal 8.73 x 1.78
16	2.3199.001.2	2	plug 1/2" gas
17	2.1560.054.0	2	gasket 21 x 26
19	2.4419.340.0	2	oil filter element
22	0.007.0638.2	6	sprayers
23	2.1099.108.2	6	special nut m 10 p.1
24	2.1560.006.0	12	gasket 10.2 x 16
25	2.3249.022.2	6	pipe fitting m 10 p.1
26	2.1470.004.2	34	lock washer 8
27	2.0112.237.2	2	screw m 8 p.1.25x140
28	2.0112.215.2	25	screw m 8 p.1.25 x 40
29	0.007.1311.0/10	1	oil sump
30	2.0112.229.2	3	screw m 8 p.1.25 x 100
32	2.0112.241.2	4	screw m 8 p.1.25 x 160
33	2.0112.235.2	2	screw m 8 p.1.25 x 130

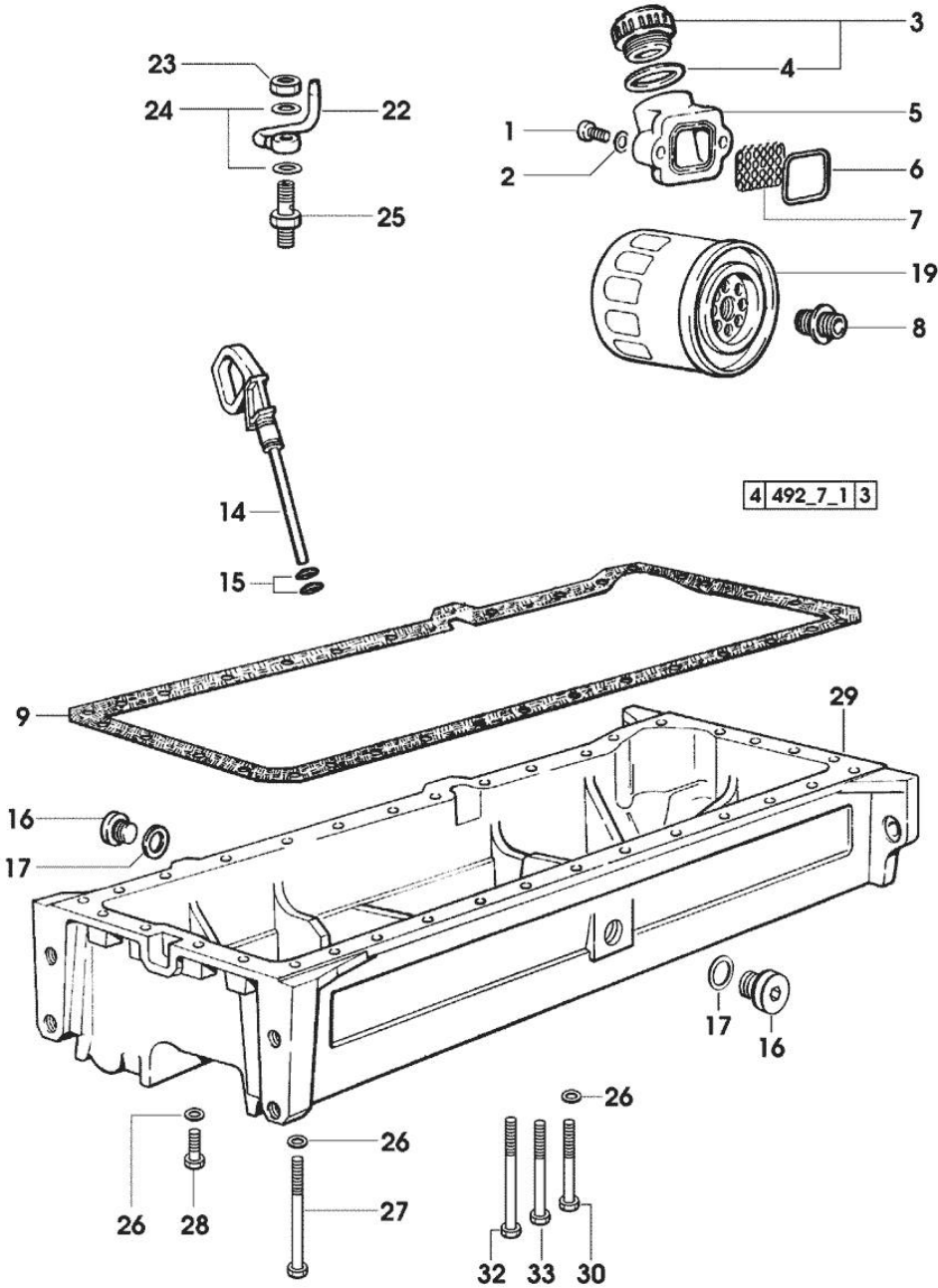

Section: ENGINE
LUBRICATION

Fig.	P/n	QTY	Name
------	-----	-----	------

Notes:
[H-6190 MASTER]

1	0.007.0703.0/10	1	box
2	0.007.1239.3	1	radiator
3	2.1560.014.0	1	washer 18.2 x 24
4	2.3120.101.0	1	plug m 18 p.1.5
5	0.078.1557.0/10	2	gasket
6	0.078.1556.0/10	1	gasket
7	0.078.1555.0/10	1	plate
8	2.1310.004.2	8	flat washer 8.4x17
9	2.0112.205.2	8	screw m 8 p.1.25 x 16
10	2.1480.014.1	4	washer 8
11	2.0312.220.1	2	screw m 8 p.1.25x70
12	2.0312.222.2	2	screw m 8 p.1.25 x 80
13	2.1539.048.0	1	special oil seal 20.35x1.78
14	2.1539.050.0	1	special oil seal 69.57x1.78
15	2.3249.023.1	2	pipe fitting m 24 p.2
16	2.3350.008.1	2	nosepiece 18

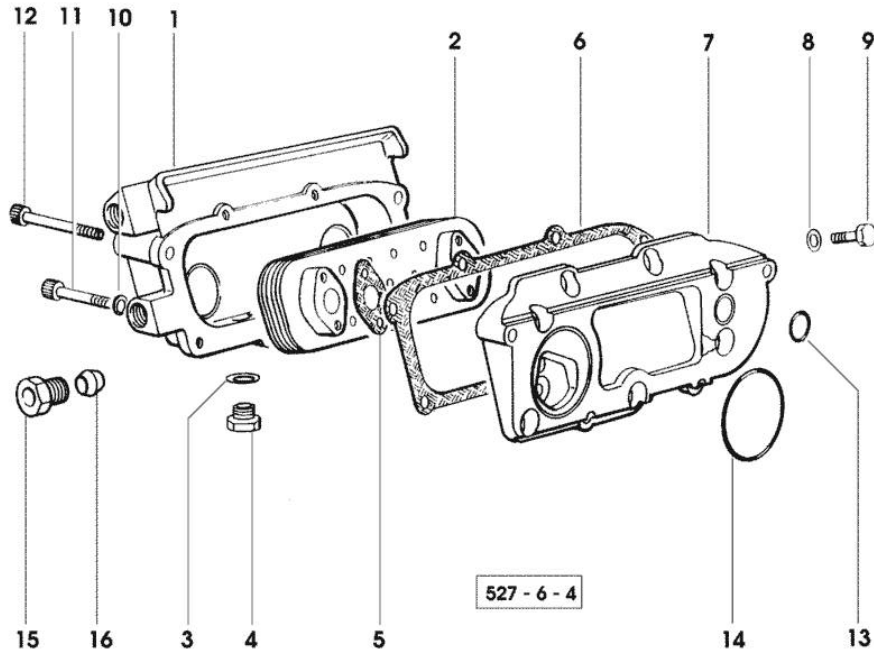

Section: ENGINE
LUBRICATION

492 - 8 1

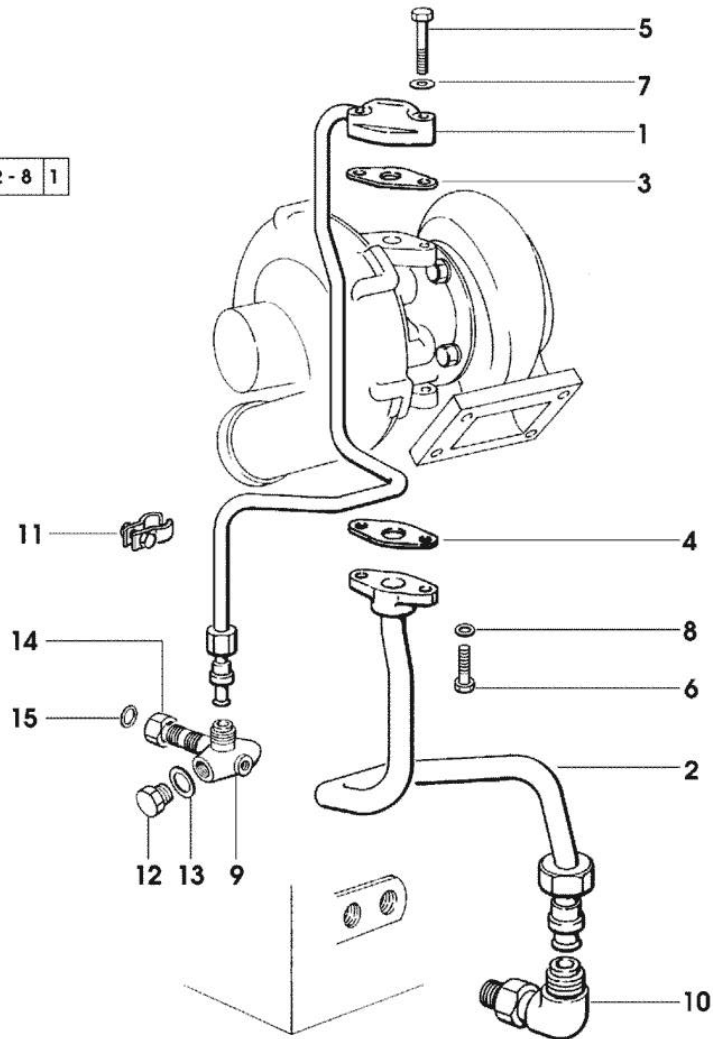

Fig.	P/n	QTY	Name
------	-----	-----	------

Notes:
[H-6190 MASTER]

1	0.007.1300.3	1	tube
2	0.007.1301.3	1	tube
3	0.052.1557.0	1	gasket
4	0.052.1558.0/10	1	gasket
5	2.0312.212.2	2	screw m 8 p.1.25 x 35
6	2.0112.207.2	2	screw m 8 p 1.25 x 20
7	2.1480.014.1	2	washer 8
8	2.1470.004.2	2	lock washer 8
9	2.3339.673.0/10	1	pipe fitting
			* 1506 <= X MASTER H-6165
			* 1649 <= X MASTER H-6190
			- N.1 - 2.3110.403.7 - 2.1560.009.0
			- N.1 - 2.1011.129.2/10 - 2.1530.038.0
10	2.3264.021.2	1	pipe fitting m 22 p.1.5 - 1" 1/16
11	0.007.1317.4	1	bracket
12	2.3110.403.7	1	plug m 14 p.1.5
13	2.1560.010.0	1	gasket 14.2 x 20
14	2.1019.129.2/10	1	nut m 18 p.1.5x12
15	2.1530.038.0	1	oil seal 15.54x2.62

Section: ENGINE
LUBRICATION

Fig.	P/n	QTY	Name
------	-----	-----	------

Notes:
[H-6190 MASTER]

1	0.007.1312.3	1	tube (...) <-
2	2.1470.004.2	2	lock washer 8
3	2.1470.004.2	1	lock washer 8
4	2.0112.205.2	1	screw m 8 p.1.25 x 16
5	0.007.0997.0	1	gasket (...) <-
6	2.0112.207.2	2	screw m 8 p 1.25 x 20
7	2.1539.153.0	1	oil seal 32.99x2.6 -> (...)
8	2.0112.322.2	3	screw m 10 p.1.5x65
9	2.1310.006.2	3	flat washer 10.5x21
10	0.007.0972.0	2	shim
11	0.007.0973.0	2	shim
12	0.007.0867.0	1	bush
13	0.000.0000.1	1	cannot be supplied * (...) <- - N.1 - 010.0194.4/30 - 011.0087.4 - 2.1539.153.0
14	0.007.1371.0	1	piston
15	0.007.1373.0	1	spring
16	0.007.1372.0	1	cup
17	0.007.1438.0/10	1	gear
18	0.007.1437.0	1	washer
19	0.007.1436.0	1	circlip
20	0.000.0000.1	1	cannot be supplied
21	0.011.0087.4	1	tube -> (...)
22	0.010.0194.4/30	1	oil pump -> (...) ☞ 0.010.0194.4/30 ☞ 01.00.30

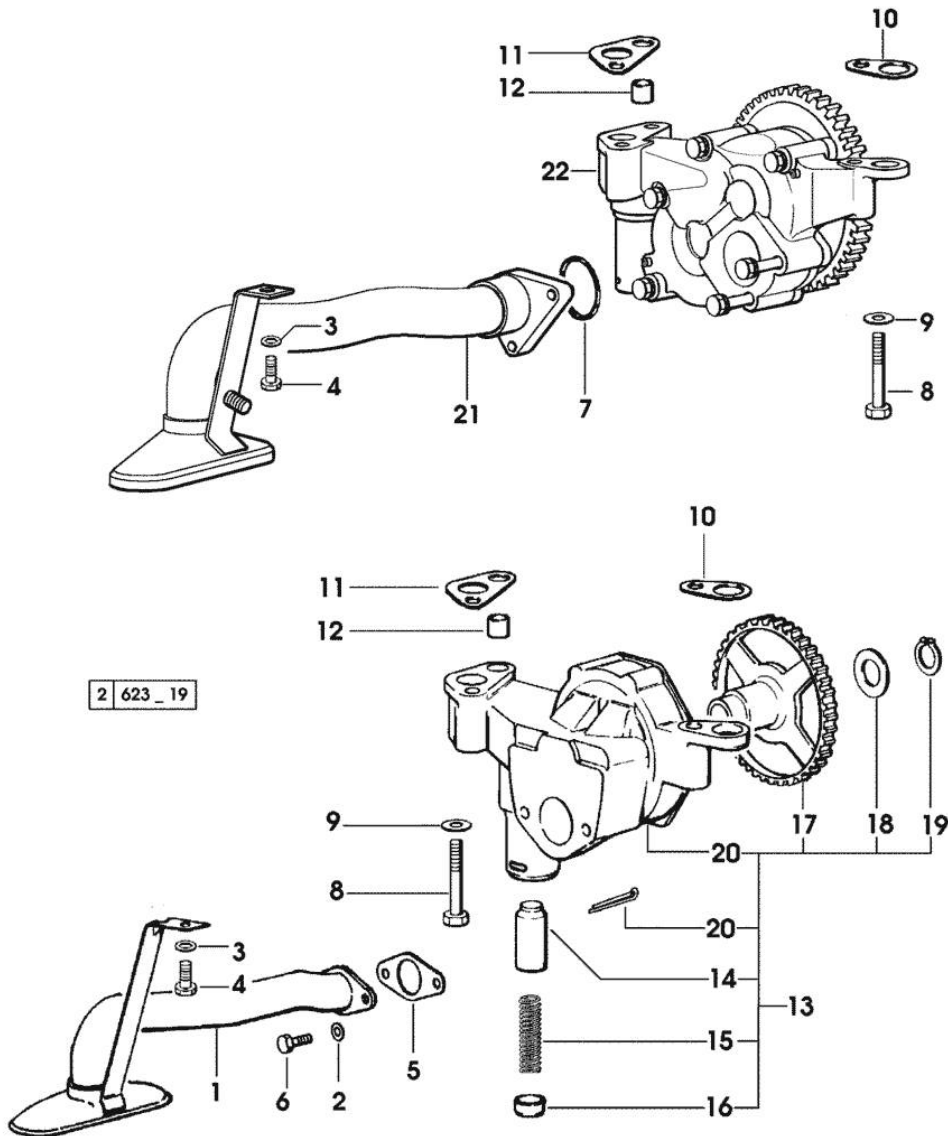

Section: ENGINE

OIL PUMP

Fig.	P/n	QTY	Name
------	-----	-----	------

Notes:
[H-6190 MASTER]

1	0.010.0194.4/30	1	oil pump ☞ 0.010.0194.4/30
2	0.007.0866.3/10	1	valve
3	0.010.1709.0	1	gear z=8
4	2.0112.220.2	2	screw m 8 p.1.25x55
5	2.1475.002.7	6	washer 8.4
6	2.0112.219.2	2	screw m 8 p.1.25x55
7	0.010.0195.3/20	1	cover
8	2.1410.064.7	1	circlip
9	0.010.1708.0/20	1	gear z=8
10	2.1651.204.0	1	pin 3x10
11	0.000.0000.1		cannot be supplied
12	0.000.0000.1		cannot be supplied
13	2.1560.020.0	1	copper gasket 24.3x32
14	2.0112.217.2	2	screw m 8 p.1.25 x 45
15	2.1630.608.0	2	pin 6x16
16	0.000.0000.1		cannot be supplied

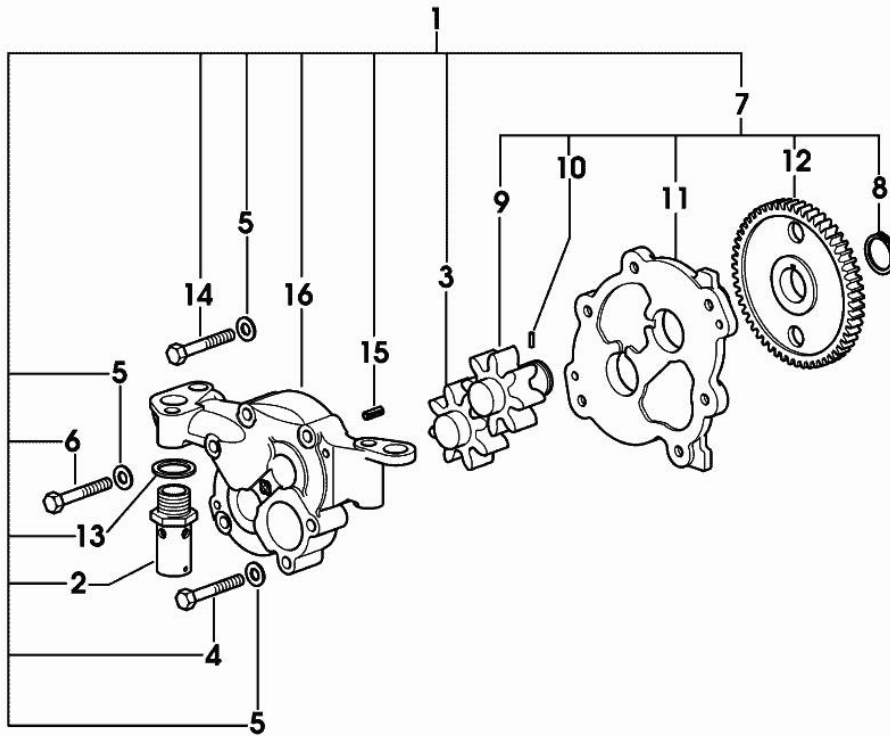

0_010_0194_4_30

Section: ENGINE
LUBRICATION

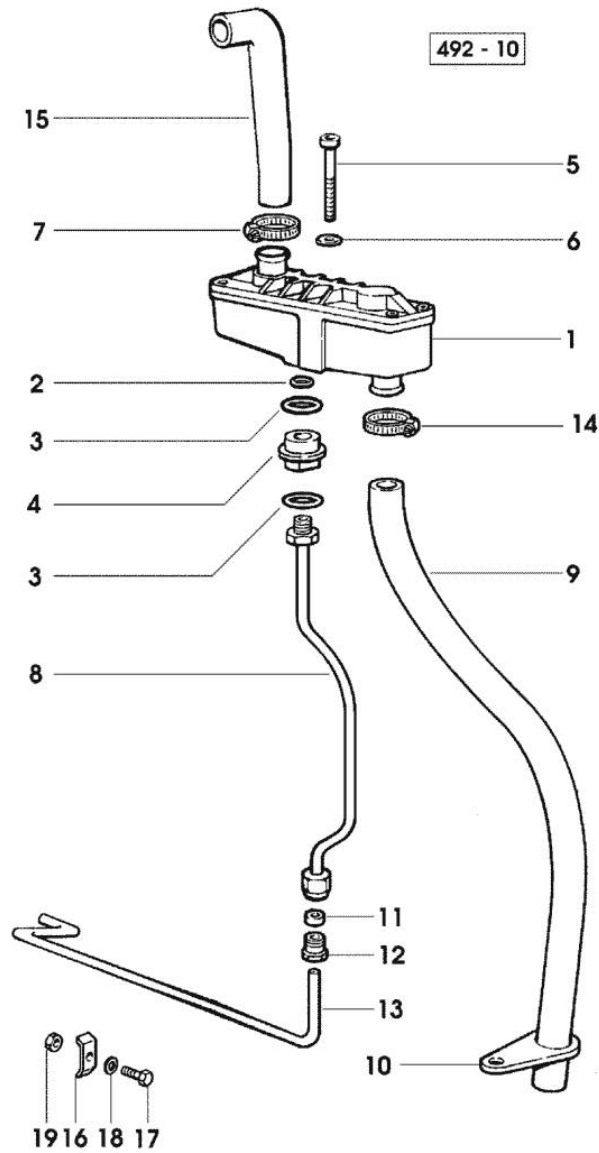

Notes:
[H-6190 MASTER]

Fig.	P/n	QTY	Name
1	0.075.1557.4	1	sediment bowl
2	2.1560.008.0	1	gasket 12.2 x 18
3	2.1539.072.0	2	special oil seal 23.52 x 1.78
4	0.075.1553.0	1	bush
5	2.0312.221.2	2	screw m 8 p.1.25x75
6	2.1480.014.1	2	washer 8
7	2.6859.086.0	2	clamp
8	0.007.0861.0	1	tube
9	0.075.1554.0	1	tube
10	0.075.1151.0	1	bracket
11	2.3350.003.1	1	nosepiece 8
12	2.3339.418.1	1	pipe fitting m 12 p.1
13	0.007.0970.0	1	tube
14	2.6859.086.0	1	clamp
15	0.075.1453.0/10	1	tube
16	0.002.8816.0	1	small plate
17	2.0112.007.2	1	screw m 6 p.1 x 20
18	2.1310.002.2	1	flat washer 6.4x12.5
19	2.1011.103.2	1	nut m 6 p.1

LUBRICATION

Fig.	P/n	QTY	Name
------	-----	-----	------

Notes:
 [H-6190 MASTER]

1	2.6850.004.0	4	clamp
3	0.011.1208.0	1	tube
4	0.010.6507.0	1	valve
5	0.011.1209.0	1	tube
6	0.010.6512.4	1	sediment bowl
7	0.010.6513.3	1	cover
8	0.075.1559.0	1	gasket
9	2.0351.203.2	4	screw 3.5x9.5
10	0.010.6512.0	1	sediment bowl

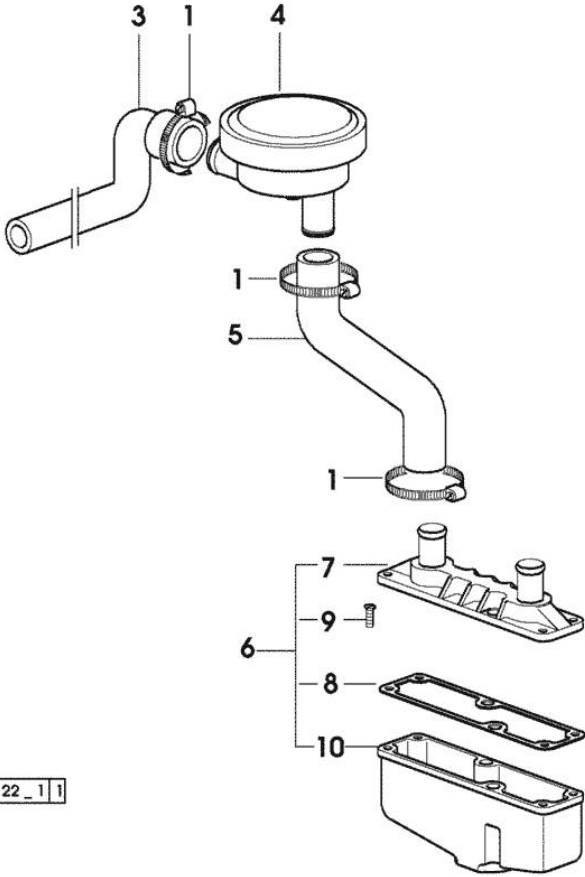

4 | 624_22_1 | 1

Thank you so much for reading.
Please click the “Buy Now!”
button below to download the
complete manual.



After you pay.

You can download the most
perfect and complete manual in
the world immediately.

Our support email:

ebooklibonline@outlook.com