

Section: ENGINE
CRANKCASE

Fig.	P/n	QTY	Name
------	-----	-----	------

Notes:
 [PRINCE 435 ->5001]

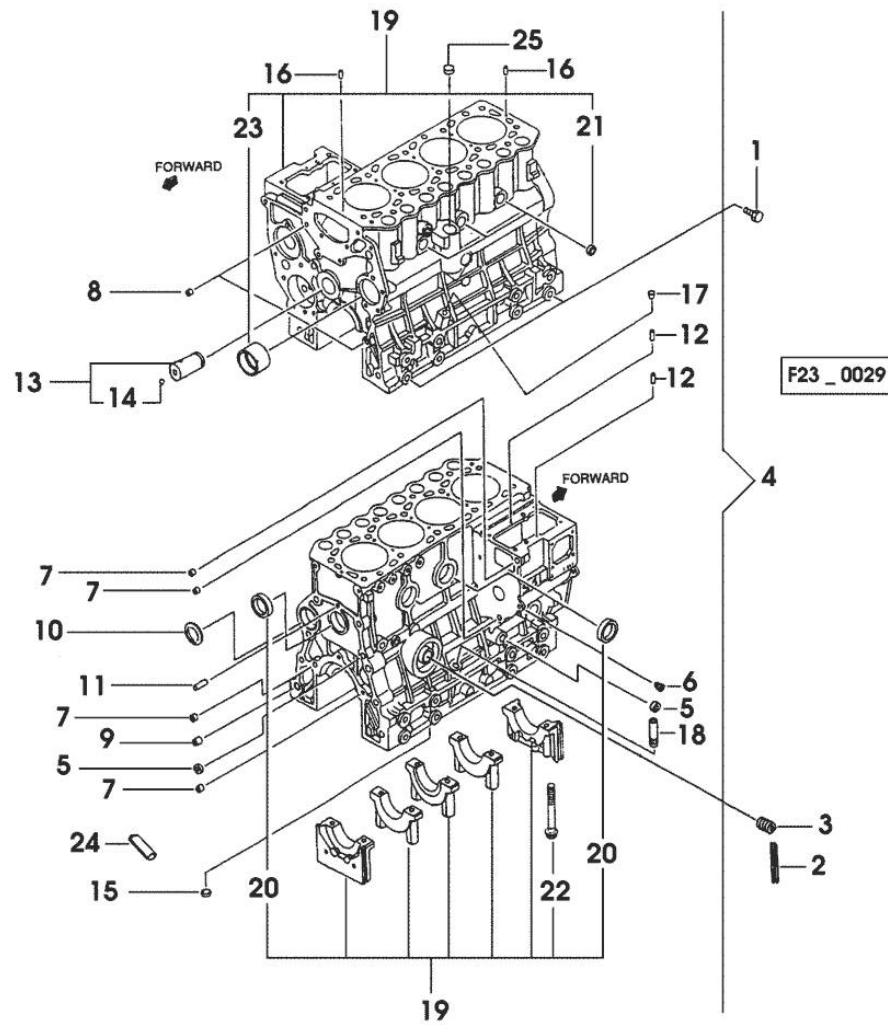

1	0.010.2648.1	4	screw
2	0.010.2651.2	4	gasket
3	0.010.2650.2	1	pipe fitting
4	0.010.2653.2	1	crankcase
			- X 35HP
4	0.010.2654.0	1	crankcase
			- X 45HP
5	0.010.2649.1	3	special bushing
6	0.009.4545.1	1	plug
7	0.009.4524.2	4	special bushing
8	0.009.4525.1	2	special bushing
9	0.009.4525.2	1	special bushing
10	0.009.4524.1	1	expansion plug
11	0.009.4524.0	1	pin
12	0.009.4523.0	2	pin
13	0.010.2650.0	1	pin
14	0.010.2650.1	1	ball
15	0.010.2649.0	1	plug
			- X 35HP
16	0.010.2651.0	2	pin
17	0.010.2651.1	1	plug
18	0.009.4523.2	1	guide
19	0.000.0000.1		cannot be supplied
20	0.010.2652.1	3	special bushing
21	0.010.2652.2	3	special bushing
22	0.010.2653.0	10	screw
23	0.010.2653.1	1	special bushing
24	0.010.2654.1	4	tube
			- X 45HP
25	0.010.2648.2	1	plug

Section: ENGINE
CRANKCASE

Fig.	P/n	QTY	Name
------	-----	-----	------

Notes:
 [PRINCE 435 ->5001]

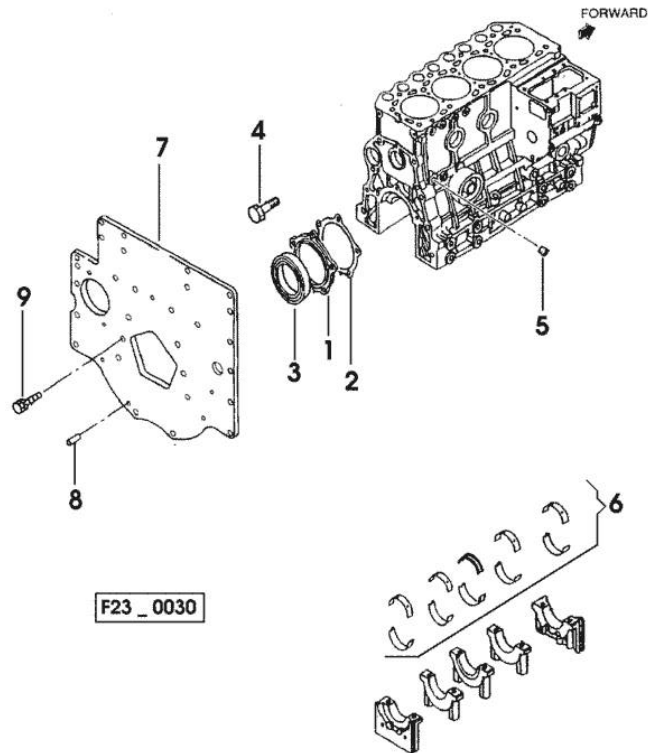

1	0.010.2654.2	1	flange
2	0.010.2655.0	1	gasket
3	0.010.2655.1	1	special oil seal
4	0.010.2655.2	5	screw
5	0.009.4530.0	1	plug
			- X 35HP
6	0.009.4531.0	1	main half bushing STANDARD
			- X 35HP
6	0.009.4531.1	1	main half bushing - mm 0.25
			- X 35HP
6	0.009.4531.2	1	main half bushing - mm 0.50
			- X 35HP
6	0.009.4532.0	1	main half bushing - mm 0.75
			- X 35HP
6	0.010.2656.2	1	main half bushing STANDARD
			- X 45HP
6	0.010.2657.0	1	main half bushing - mm 0.25
			- X 45HP
6	0.010.2657.1	1	main half bushing - mm 0.50
			- X 45HP
6	0.010.2657.2	1	main half bushing - mm 0.75
			- X 45HP
7	0.010.2656.0	1	flange
8	0.009.4532.2	1	pin
9	0.010.2656.1	6	screw

Section: ENGINE

TIMING CASE

Fig.	P/n	QTY	Name
------	-----	-----	------

Notes:

[PRINCE 435 ->5001]

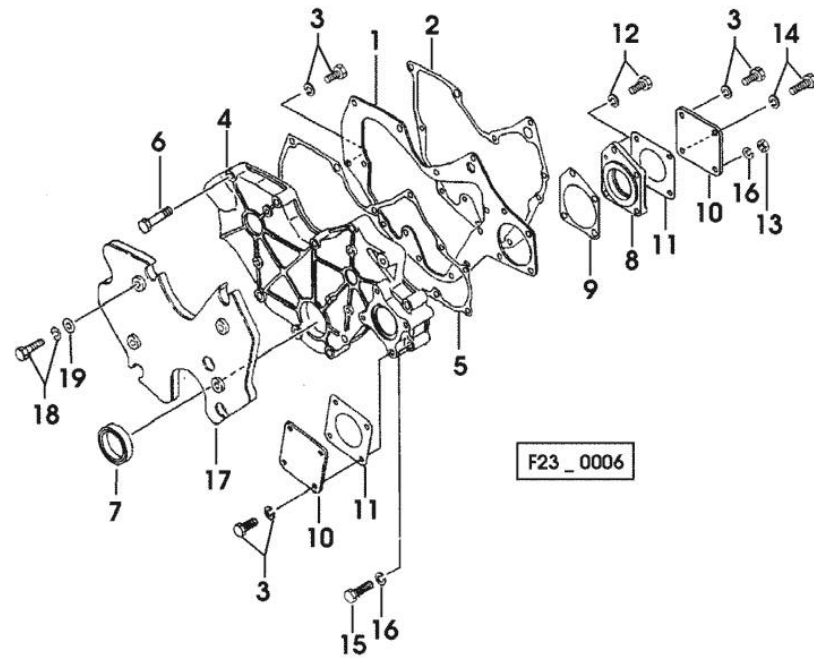

1	0.010.2658.0	1	plate
2	0.010.2658.1	1	gasket
3	0.010.2639.1	10	screw
4	0.010.2658.2	1	flange
5	0.010.2659.0	1	gasket
6	0.010.2659.1	8	screw
7	0.010.2659.2	1	special oil seal
8	0.010.2660.0	1	flange
9	0.010.2660.1	1	gasket
10	0.009.4756.0	2	cover
11	0.010.2660.2	2	gasket
12	0.010.2661.0	1	screw
13	0.010.2661.1	2	nut
14	0.010.2661.2	1	screw
15	0.010.2662.0	2	screw
16	0.009.4539.2	2	spring washer
17	0.010.2662.1	1	cover
18	0.010.2662.2	4	screw
19	0.010.2663.0	4	washer

Section: ENGINE
CRANKSHAFT

Fig.	P/n	QTY	Name
------	-----	-----	------

Notes:
 [PRINCE 435 ->5001]

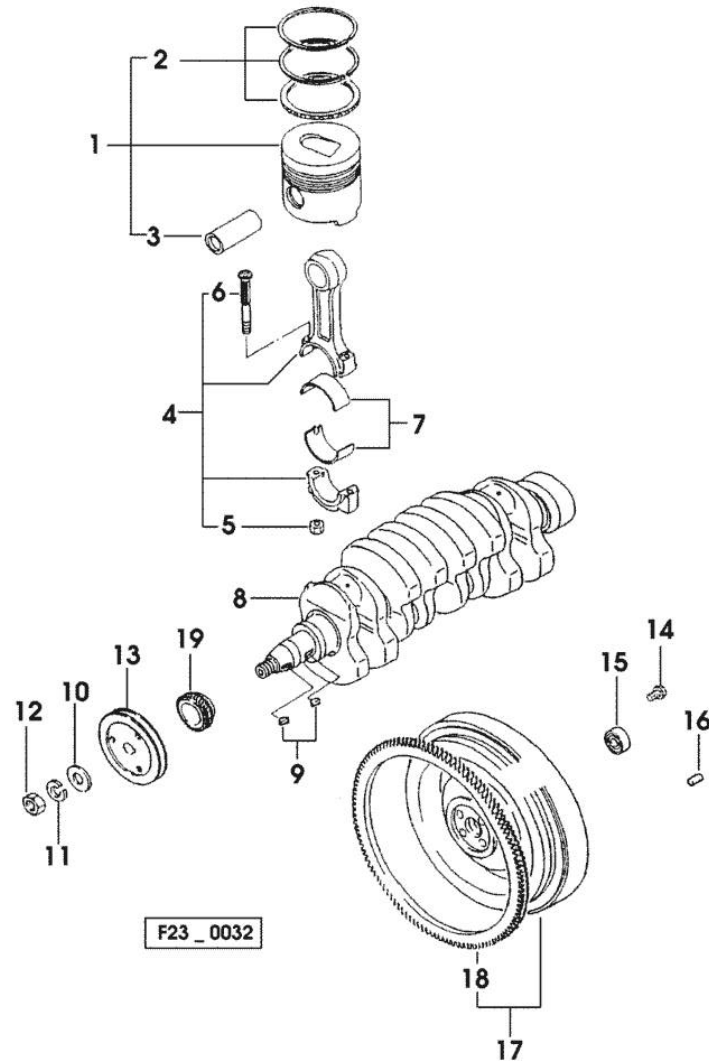

1	0.007.0060.6	4	complete piston STANDARD - X 35HP
1	0.007.0061.6	4	complete piston + mm 0.25 - X 35HP
1	0.007.0062.6	4	complete piston + mm 0.50 - X 35HP
1	0.009.0060.6	4	complete piston STANDARD - X 45HP
1	0.009.0061.6	4	complete piston + mm 0.25 - X 45HP
1	0.009.0062.6	4	complete piston + mm 0.50 - X 45HP
2	0.008.0052.6	4	piston ring set STANDARD
2	0.008.0053.6	4	piston ring set + mm 0.25
2	0.008.0054.6	4	piston ring set + mm 0.50
3	0.010.2668.0	4	piston pin
4	0.010.2671.2	4	engine connecting rod
5	0.009.4783.0	8	nut
6	0.010.2668.2	8	screw
7	0.009.4782.1	4	con.rod half bushing STANDARD
7	0.010.2669.0	4	con.rod half bushing - mm 0.25
7	0.010.2669.1	4	con.rod half bushing - mm 0.50
7	0.010.2669.2	4	con.rod half bushing - mm 0.75
8	0.010.2672.0	1	crankshaft
9	0.009.4555.1	2	key
10	0.009.4554.2	1	flat washer
11	0.009.4555.0	1	spring washer
12	0.009.4554.1	1	nut
13	0.010.2672.1	1	pulley - X 35HP
13	0.010.2672.2	1	pulley - X 45HP
14	0.009.4557.0	4	screw
15	0.009.4556.1	1	special bearing
16	0.009.4556.2	3	pin
17	0.010.2673.0	1	flywheel
18	0.010.2671.0	1	crown wheel Z=110
19	0.010.2671.1	1	gear

Section: ENGINE

CAMSHAFT

Fig.	P/n	QTY	Name
------	-----	-----	------

Notes:

[PRINCE 435 ->5001]

1	0.010.2674.1	1	gear Z = 56
2	0.010.2674.2	1	gear Z = 56
2	0.010.2675.0	1	gear Z = 56 - EXPORT U.S.A.
3	0.010.2675.1	1	gear Z = 39

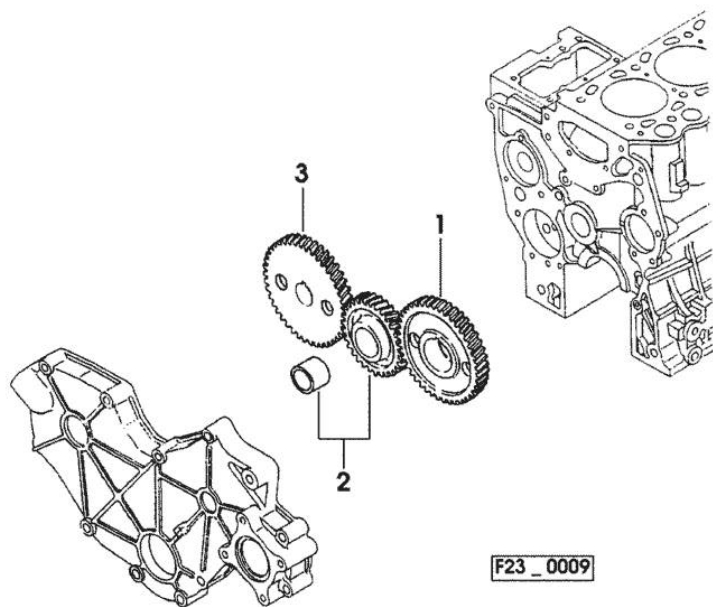

Section: ENGINE

CAMSHAFT

Fig.	P/n	QTY	Name
------	-----	-----	------

Notes:
[PRINCE 435 ->5001]

1	0.010.2647.1	1	cover
2	0.010.2647.2	1	gasket
3	0.010.2645.2	5	screw
4	0.009.4548.0	1	plug
5	0.010.2648.0	1	camshaft
6	0.009.4555.1	1	key
7	0.010.2646.1	1	small plate
8	0.010.2639.1	2	screw
9	0.009.4562.2	8	tappets
10	0.010.2646.2	8	rod
11	0.009.4781.2	1	tube - X 45HP
11	0.010.2647.0	1	tube - X 35HP
12	0.010.2206.0	1	clamp - X 45HP

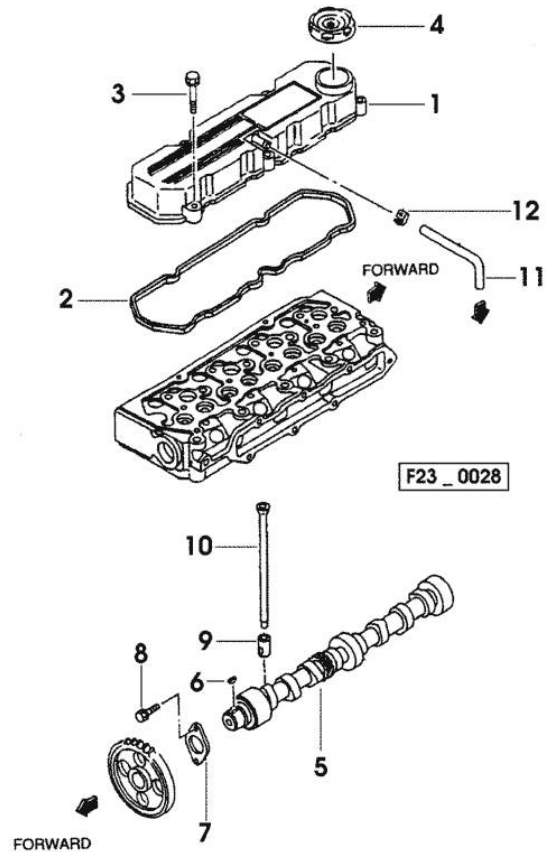

Section: ENGINE
CYLINDER HEAD

Fig.	P/n	QTY	Name
------	-----	-----	------

Notes:
[PRINCE 435 ->5001]

1	0.010.2637.2	4	inlet valve Ø mm 6.5
2	0.010.2638.0	4	exhaust valve Ø mm 6.5
3	0.010.2638.1	8	spring
4	0.010.2638.2	8	cup
5	0.009.4561.2	16	stop
6	0.009.4562.0	8	gasket
7	0.010.2639.0	8	cap
8	0.010.2639.1	1	screw
9	0.010.2644.0	1	camshaft
10	0.009.4567.0	1	special bearing
11	0.009.4566.0	1	washer
12	0.009.4567.2	1	stick
13	0.000.0000.1	1	cannot be supplied
14	0.010.2640.1	1	screw
15	0.009.4559.0	2	ring
16	0.010.2640.2	8	rocker arm
17	0.010.2641.0	8	nut
18	0.010.2641.2	8	screw
19	0.010.2642.0	1	support
20	0.010.2642.1	2	support
21	0.010.2644.1	1	shaft
22	0.010.2643.0	2	plug
23	0.010.2643.1	2	spring
24	0.010.2643.2	3	screw

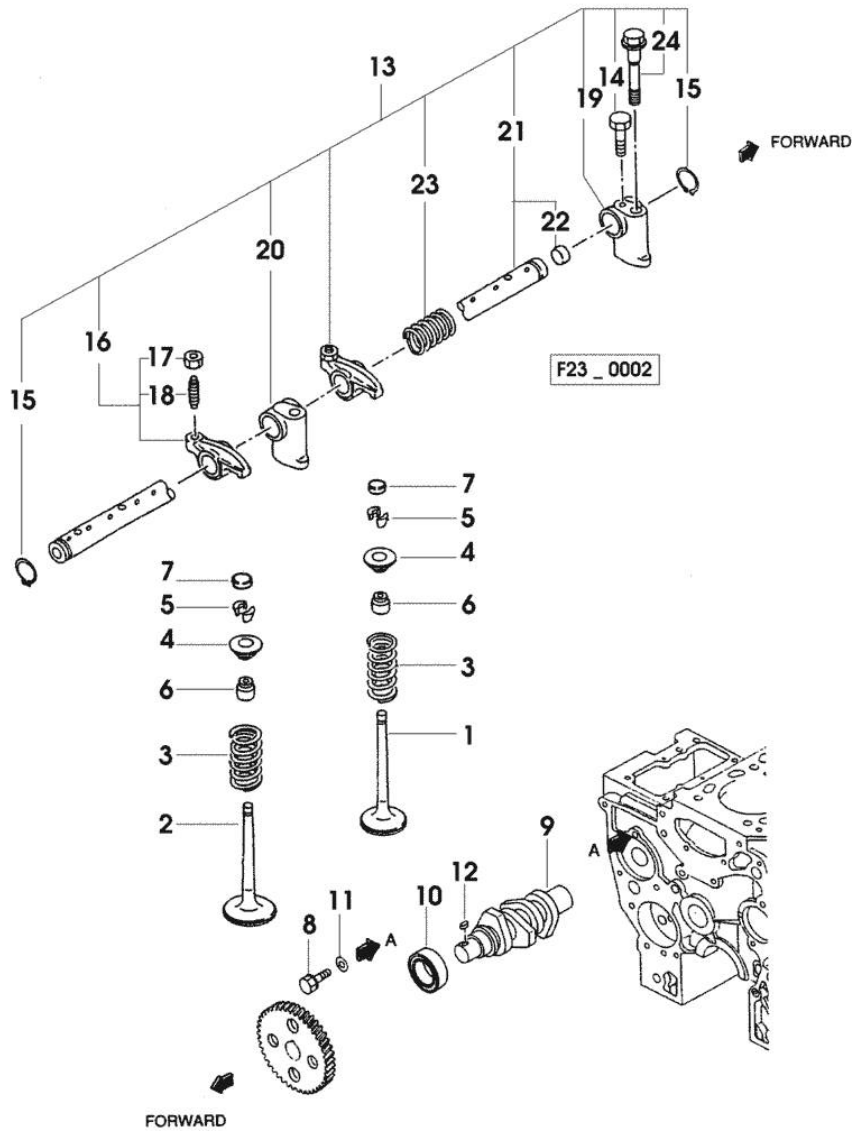

Section: ENGINE
CYLINDER HEAD

Fig.	P/n	QTY	Name
------	-----	-----	------

Notes:
[PRINCE 435 ->5001]

1	0.010.2633.0	2	screw
2	0.009.4541.2	2	bracket
3	0.010.2633.1	14	screw
4	0.010.2635.2	1	gasket
5	0.010.2636.0	1	engine head
6	0.009.4545.1	1	plug
7	0.010.2634.1	1	plug
8	0.010.2636.1	7	plug
9	0.010.2634.2	4	valve guide
10	0.010.2635.0	4	valve guide
11	0.010.2636.2	4	special bushing

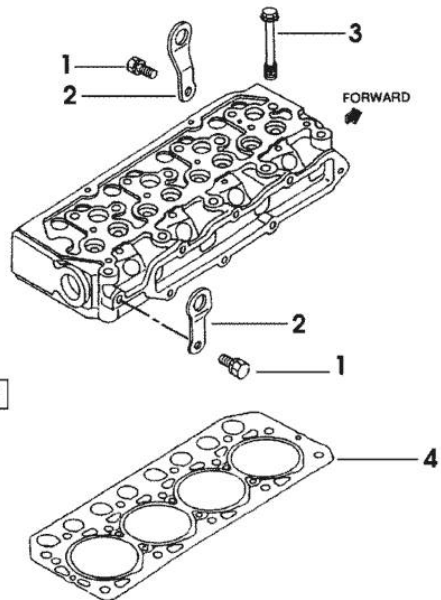
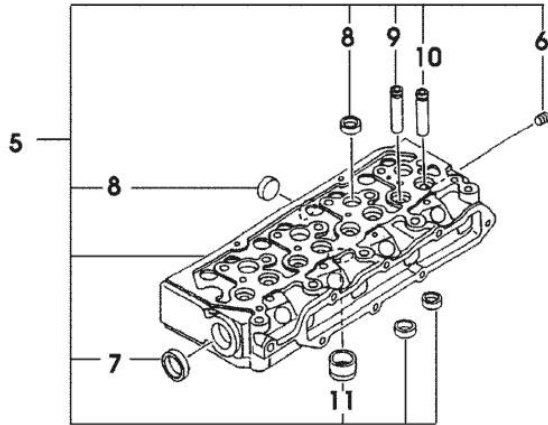

Section: ENGINE
CYLINDER HEAD

Fig.	P/n	QTY	Name
------	-----	-----	------

Notes:
- EXPORT U.S.A. [PRINCE 435 ->5001]

1	0.010.2633.0	2	screw
2	0.009.4541.2	2	bracket
3	0.010.2633.1	14	screw
4	0.010.2635.2	1	gasket
5	0.010.2637.0	1	engine head
6	0.009.4545.1	1	plug
7	0.010.2634.1	1	plug
8	0.009.4527.0	7	plug
9	0.010.2634.2	4	valve guide
10	0.010.2635.0	4	valve guide
11	0.010.2637.1	4	special bushing

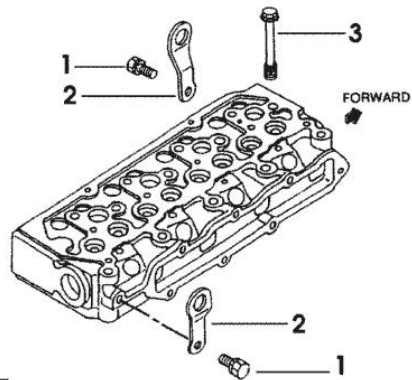
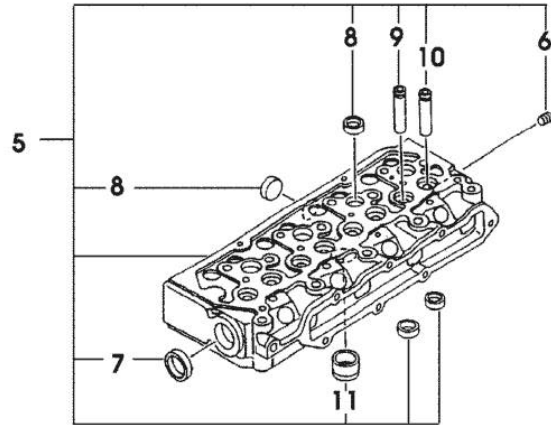

F23_0027

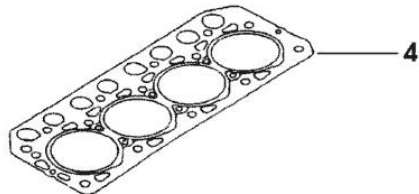

OIL PAN

Fig.	P/n	QTY	Name
------	-----	-----	------

Notes:

[PRINCE 435 ->5001]

1	0.010.2665.2	1	oil sump
2	0.010.2663.2	1	gasket
3	0.010.2664.0	1	plug
4	0.010.2664.1	12	screw
5	0.010.2664.2	1	screw
6	0.010.2665.0	4	screw
7	0.010.2665.1	5	washer

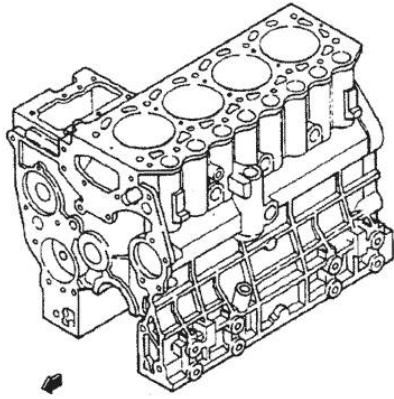

FORWARD

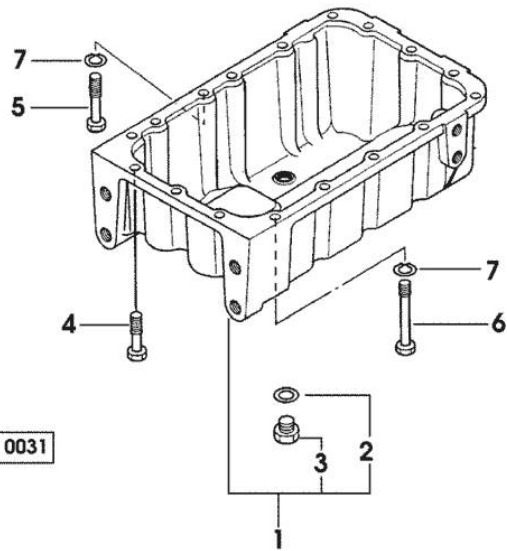

F23_0031

Section: ENGINE
LUBRICATION

Fig.	P/n	QTY	Name
------	-----	-----	------

Notes:
 [PRINCE 435 ->5001]

1	0.010.2685.2	1	tube
2	0.009.4634.0	1	self-locking nut
3	0.009.4634.1	1	gasket
4	0.010.2686.0	1	valve
5	0.010.2686.1	1	gasket
6	0.009.4794.1	1	oil filter element - X 25HP - 35HP
6	0.010.2687.0	1	oil filter element - X 45HP
7	0.010.2687.1	1	dipstick

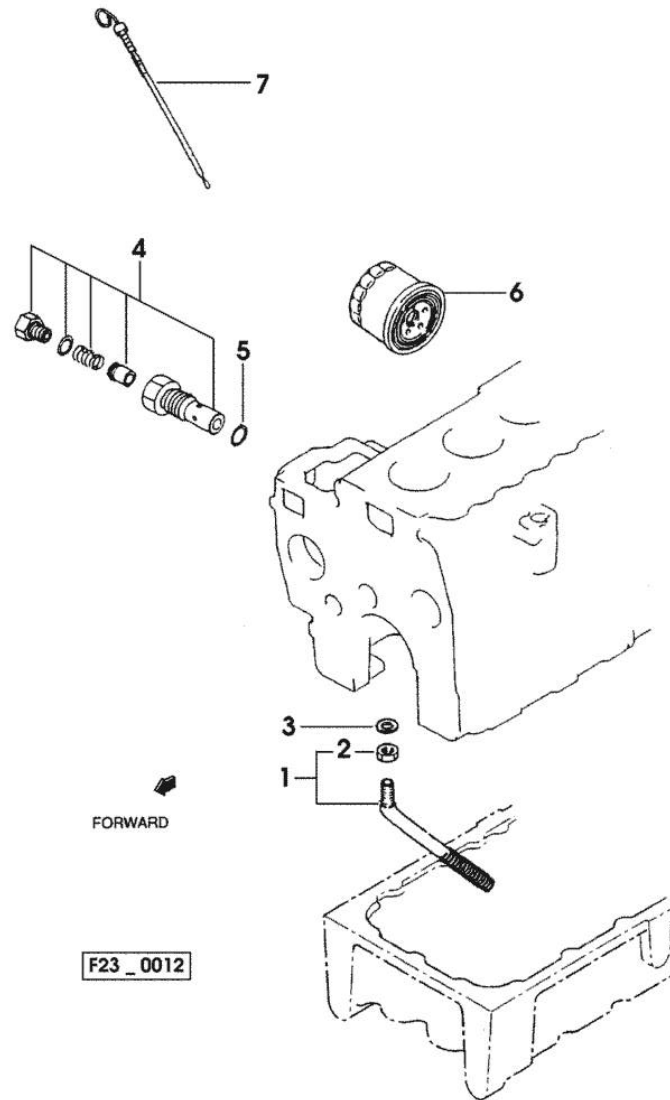

Thank you so much for reading.
Please click the “Buy Now!”
button below to download the
complete manual.



After you pay.

You can download the most
perfect and complete manual in
the world immediately.

Our support email:

ebooklibonline@outlook.com