

Section: ENGINE
CRANKCASE

9_34811_00_0_A

Fig.	P/n	QTY	Name
------	-----	-----	------

Notes:
 [ROCK 55 M]

1	0.007.1150.6/10	1	crankcase
1.1	2.3130.001.1	9	plug 1/8" gas
1.2	2.3130.002.1	2	plug 1/4" gas
1.3	2.3130.003.1	7	plug 3/8" gas
1.4	2.1324.011.0	1	plug
1.5	2.3199.092.0	3	plug 8 x 12
1.6	2.3179.012.0	1	plug 60
1.12	0.000.0000.1		cannot be supplied
1.12.1	0.065.1112.7	1	support
1.12.1.2	2.1699.165.0	1	bush 12.3x15x16
1.12.2	0.065.1114.0/10	2	support
1.12.3	0.065.1116.3	1	support
1.12.3.2	2.1699.165.0	1	bush 12.3x15x16
1.12.4	0.065.1117.0	8	screw m 12 x 100
1.12.6	0.066.1151.0	1	pin
1.12.7	0.065.1141.0	1	special bushing 59X55X30
1.12.8	0.065.1140.0	3	special bushing 59X55X20
2	2.1539.130.0/10	3	special oil seal 117.07x3.53
4	2.0432.003.7	9	stud bolt m 8 p.1.25 / p.1 x 20
5	2.1532.072.0	1	oil seal 26.70x1.78
6	2.3199.405.2	1	plug m 28 p.1.5
7	0.066.1152.0/10	4	gasket

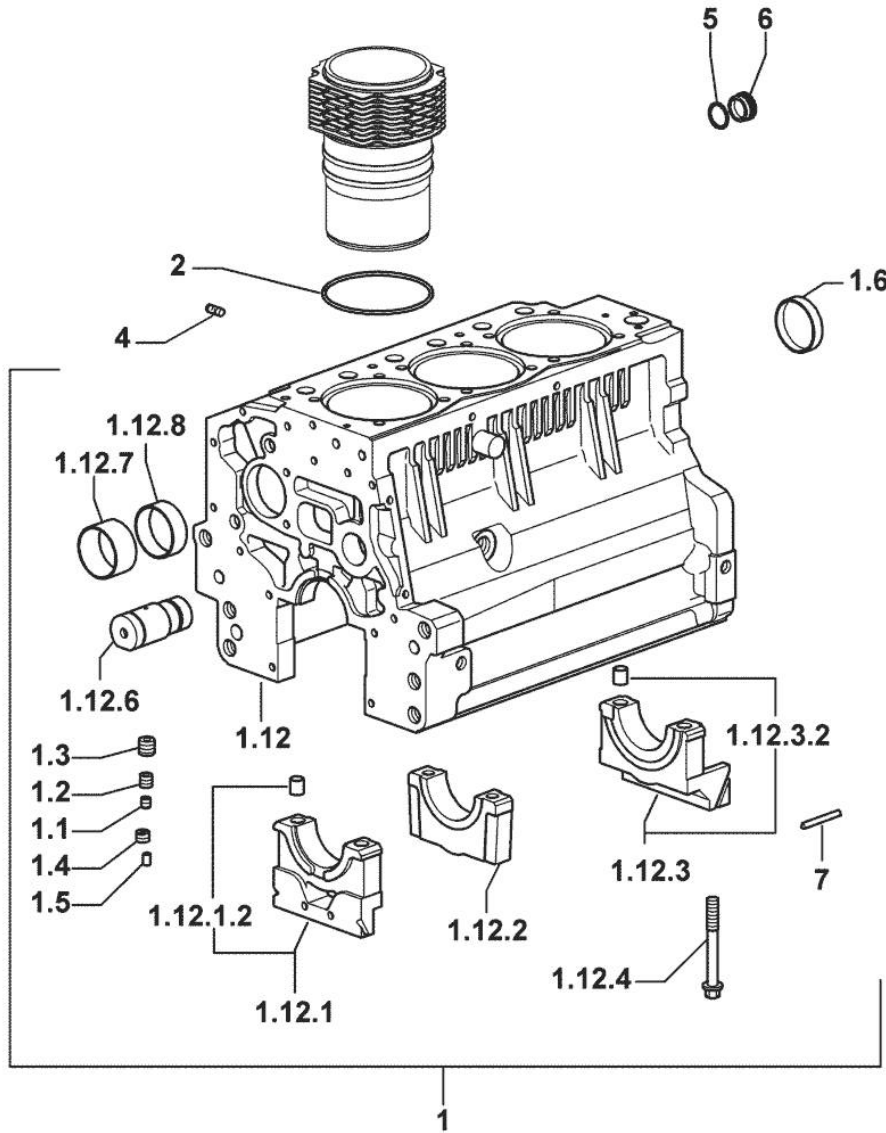
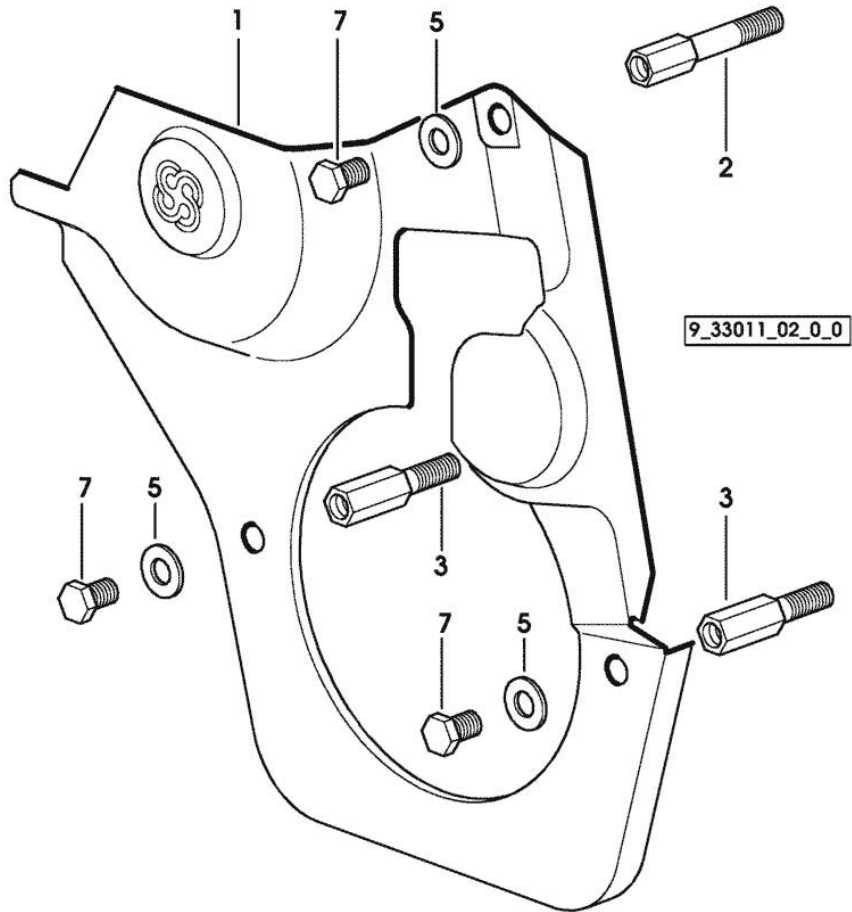

Fig.	P/n	QTY	Name
------	-----	-----	------

Notes:
 [ROCK 55 M]

1	0.007.1262.3/50	1	guard
2	0.007.1271.0/10	1	small column m 8 p.1.25 / L = mm 60
3	0.007.1272.0/10	2	small column m 8 p.1.25 / L = mm 50
5	2.1310.004.2	3	flat washer 8.4x17
7	2.0112.203.2	3	screw m 8 p.1.25 x 12



9_34811_00_0_B

Section: ENGINE
TIMING CASE

Fig.	P/n	QTY	Name
------	-----	-----	------

Notes:
[ROCK 55 M]

10	0.013.4981.0	1	guard -> 1155 X ROCK 55 -> 1187 X ROCK 60
10	0.065.1132.0/50	1	guard 1154 <- X ROCK 55 1186 <- X ROCK 60
11	0.065.1150.0/30	1	gasket
12	2.0432.003.7	2	stud bolt m 8 p.1.25 / p.1 x 20
13	2.0312.214.2	3	screw m 8 p.1.25 x 40
14	2.1480.014.1	15	washer 8
15	2.1470.004.2	4	lock washer 8
16	2.1011.405.2	2	nut m 8 p.1
17	2.1529.167.0	1	oil seal
18	2.0312.208.2	8	screw m 8 p.1.25 x 25
19	2.0312.219.2	4	screw m 8 p.1.25x65

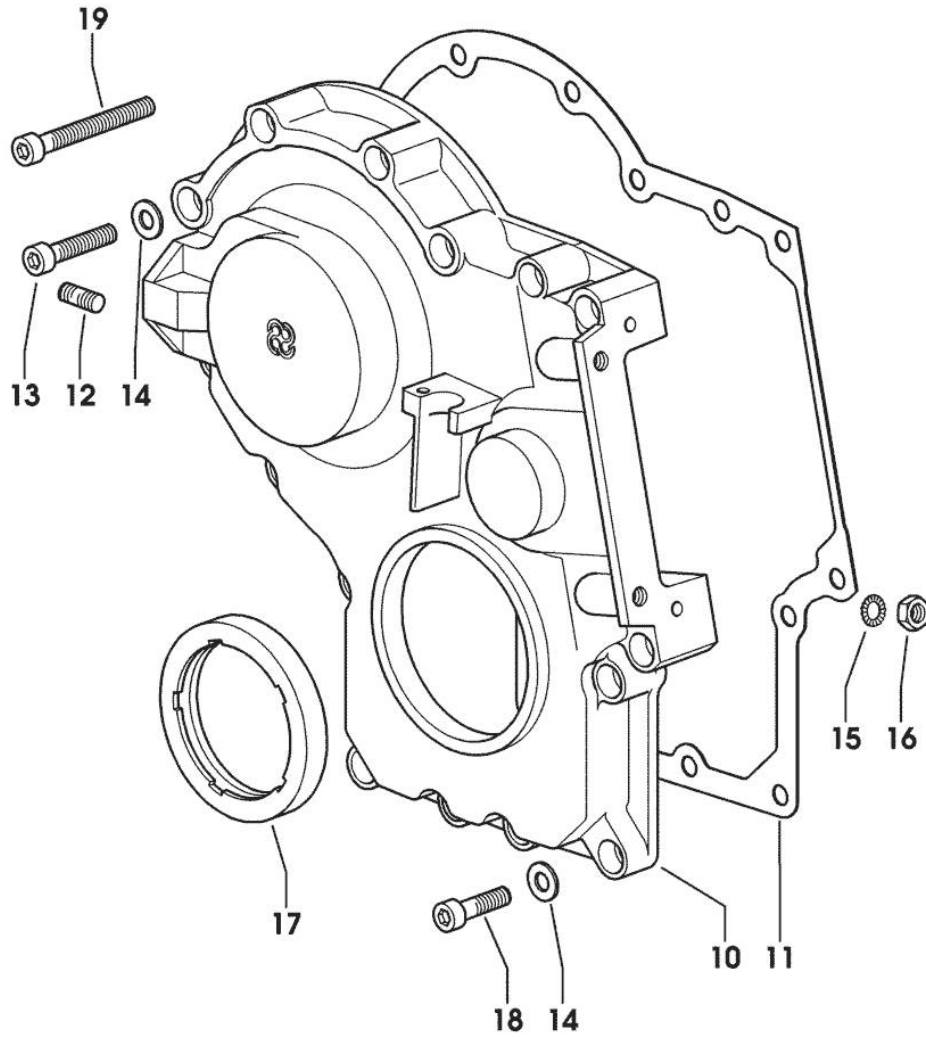

Section: ENGINE
CRANKCASE

Fig.	P/n	QTY	Name
------	-----	-----	------

Notes:
 [ROCK 55 M]

6	2.0439.250.7	1	stud bolt m 12 / m 10 x 30
7	0.011.9294.0/10	1	bush
30	2.0112.511.2	8	screw m 14 p.2 x 30
31	2.1651.912.0	2	cylindrical plug 12x28
32	2.1651.917.0	1	cylindrical plug 12x40
33	2.0432.257.7	1	stud bolt m 12 p.1.75 - 1.25 x 30
34	0.007.9745.0/10	1	flange

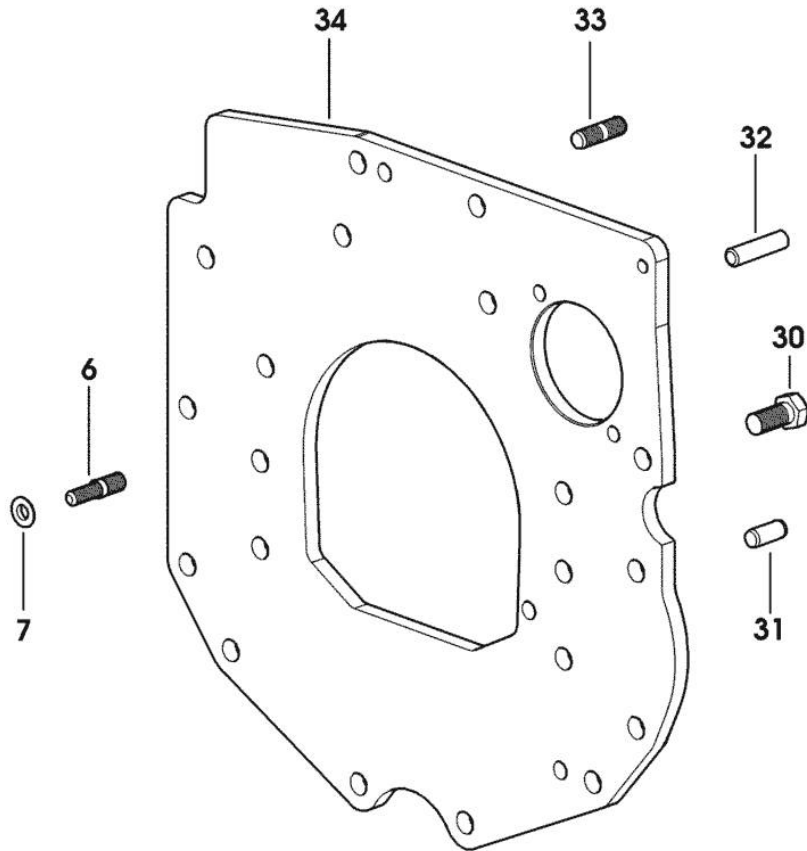

9_33311_02_0_0

Section: ENGINE
CRANKSHAFT

9_34812_00_0_0

Fig.	P/n	QTY	Name
------	-----	-----	------

Notes:
 [ROCK 55 M]

4	2.3130.001.1	3	plug 1/8" gas
6	2.1720.006.0	2	key 4x6.5
7	0.007.1554.0/20	1	crankshaft
8	0.065.1215.0	4	main half bushing STANDARD
8	0.065.1215.7		main half bushing - mm 0.25
8	0.065.1215.8		main half bushing - mm 0.50
9	0.065.1216.0	4	main half bushing
9	0.065.1216.7		main half bushing - mm 0.25
9	0.065.1216.8		main half bushing - mm 0.50
10	0.065.1218.0	4	shim STANDARD
10	0.065.1218.7		shim + mm 0.10
10	0.065.1218.8		shim + mm 0.15
15	0.065.1254.0/20	1	gasket
16	0.007.1711.0/10	1	cover
17	2.1475.002.2	9	conical washer 8
18	2.0112.207.2	9	screw m 8 p 1.25 x 20
19	2.1529.073.0	1	special oil seal 110x130x13
20	2.1651.915.0	1	pin 12x35
22	2.1599.524.7	1	washer 21x60x12

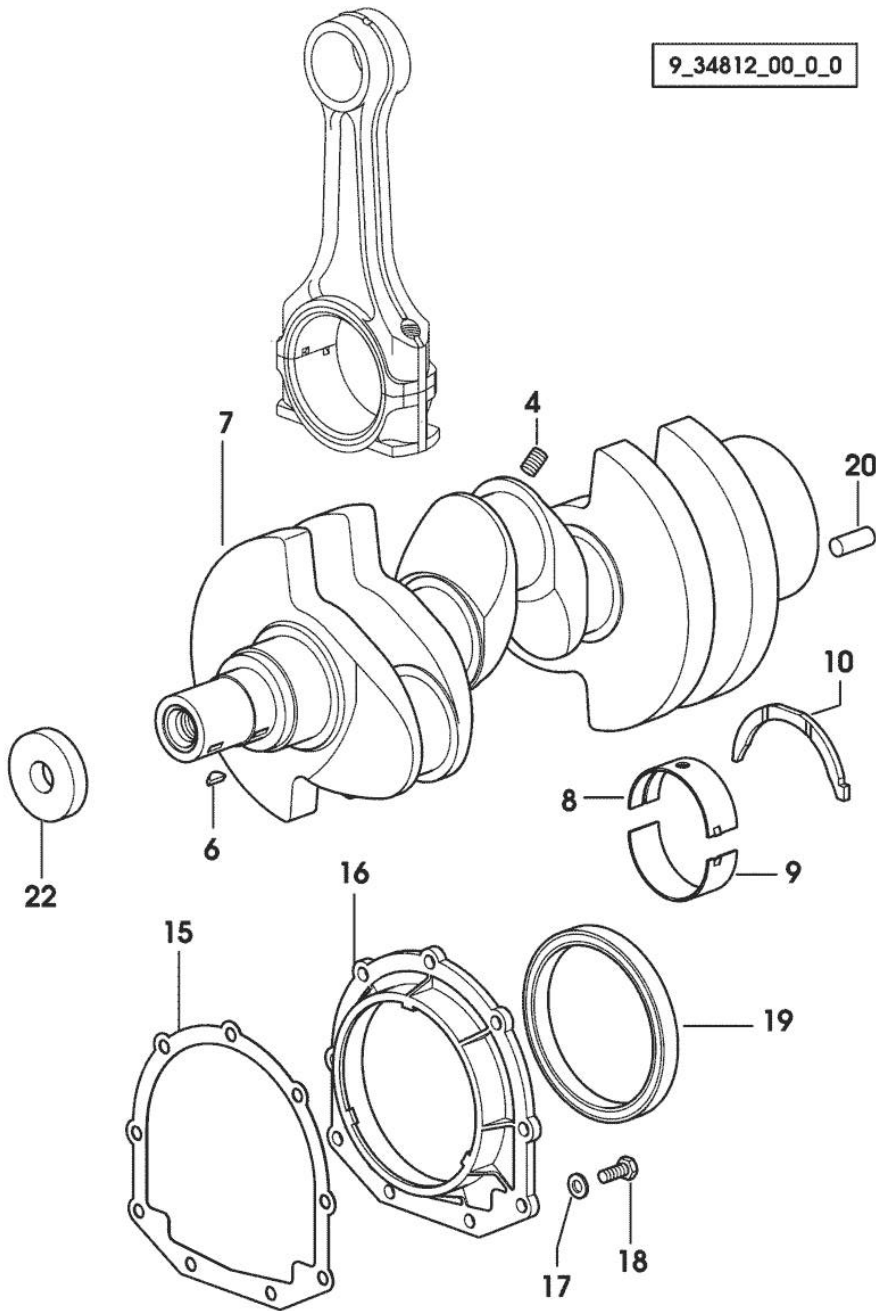

Section: ENGINE

CYLINDER - PISTON - CONNECTING ROD

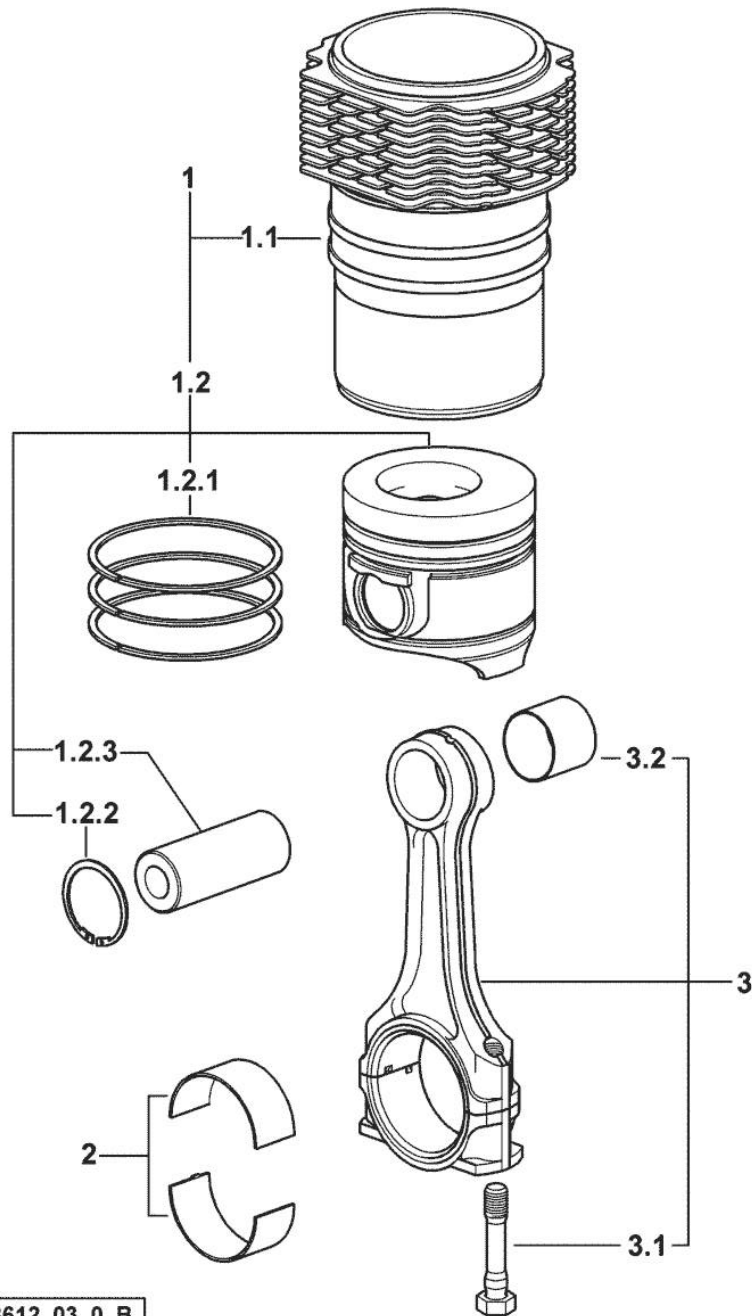

Fig.	P/n	QTY	Name
------	-----	-----	------

Notes:

29598 <= X ROCK 55 29600 <= X ROCK 60 [ROCK 55 M]

1	0.336.0065.A	3	cyl. piston assembly "A" - CLASS A
1	0.336.0065.B	3	cyl. piston assembly "B" - CLASS B
1.1	0.A13.0355.0	1	engine cylinder "A" - CLASS A
1.1	0.B13.0355.0	1	engine cylinder "B" - CLASS B
1.2	0.086.0060.A	1	complete piston "A" - CLASS A
1.2	0.086.0060.B	1	complete piston "B" - CLASS B
1.2.1	0.086.0052.6/10	1	piston ring set
1.2.2	2.1411.014.1	2	circlip 35
1.2.3	0.078.1236.0	1	piston pin Ø 18 / Ø 35 / L = mm 86
2	0.065.1225.0	6	con.rod half bushing STANDARD - A = 28.75 -> 29.00
2	0.065.1225.7	6	con.rod half bushing - mm 0.25
2	0.065.1225.8	6	con.rod half bushing - mm 0.50
3	0.078.1220.3/30	3	engine connecting rod
3.1	2.0399.213.0	2	screw m 12 p.1.25x61.5
3.2	2.1559.114.0/10	1	special bushing

Section: ENGINE

CYLINDER - PISTON - CONNECTING ROD

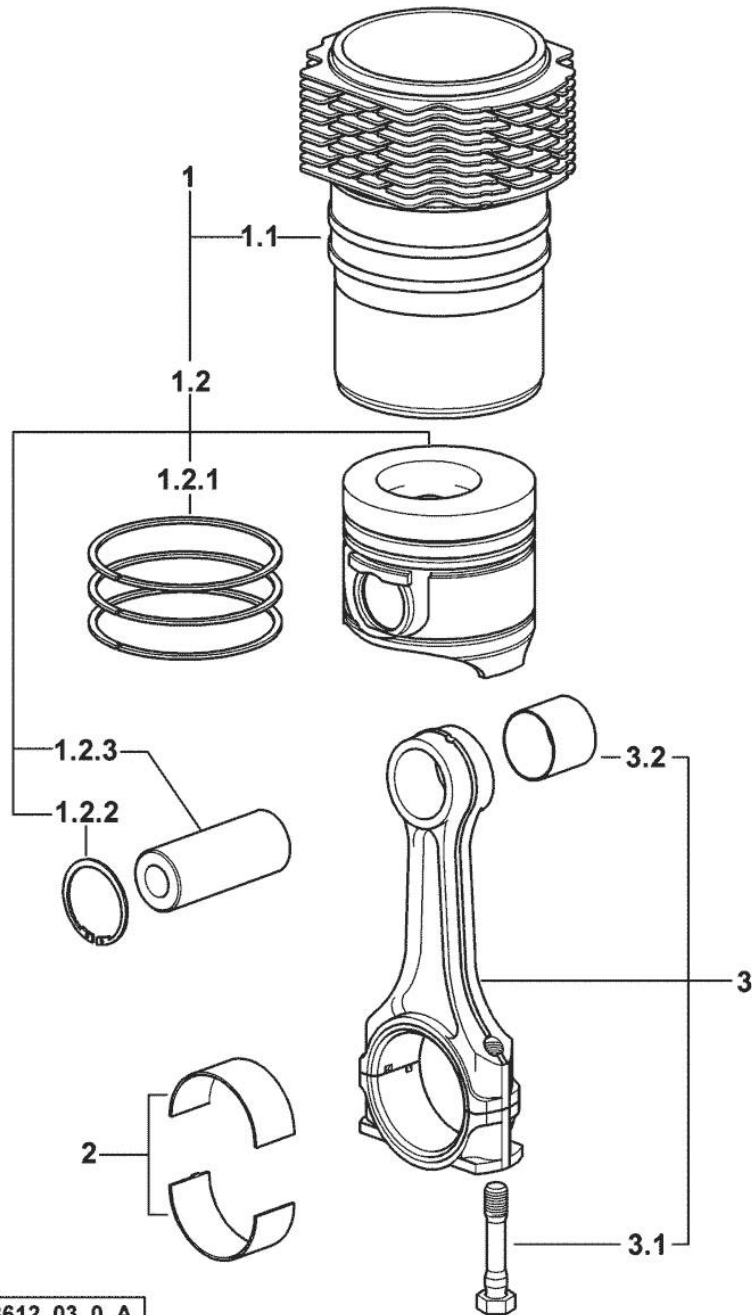

Fig.	P/n	QTY	Name
------	-----	-----	------

Notes:

=> 29599 X ROCK 55 => 29601 X ROCK 60 [ROCK 55 M]

1	0.379.0065.A	3	cyl. piston assembly "A" - CLASS A
1	0.379.0065.B	3	cyl. piston assembly "B" - CLASS B
1.1	0.A13.0355.0	1	engine cylinder "A" - CLASS A
1.1	0.B13.0355.0	1	engine cylinder "B" - CLASS B
1.2	0.379.0060.A	1	complete piston "A" - CLASS A
1.2	0.379.0060.B	1	complete piston "B" - CLASS B
1.2.1	0.086.0052.6/10	1	piston ring set
1.2.2	2.1411.014.1	2	circlip 35
1.2.3	0.078.1236.0	1	piston pin Ø 18 / Ø 35 / L = mm 86
2	0.065.1225.0	6	con.rod half bushing STANDARD - A = 28.75 -> 29.00
2	0.065.1225.7	6	con.rod half bushing - mm 0.25
2	0.065.1225.8	6	con.rod half bushing - mm 0.50
3	0.078.1220.3/30	3	engine connecting rod
3.1	2.0399.213.0	2	screw m 12 p.1.25x61.5
3.2	2.1559.114.0/10	1	special bushing

Section: ENGINE

ENGINE FLYWHEEL

Fig.	P/n	QTY	Name
------	-----	-----	------

Notes:
[ROCK 55 M]

1	0.007.9652.3/10	1	flywheel
1.2	0.069.1242.0	1	crown wheel Z = 121
2	2.0119.174.0/10	6	screw m 12 p.1.25x45
3	2.2041.008.0	1	ball bearing 20x47x14

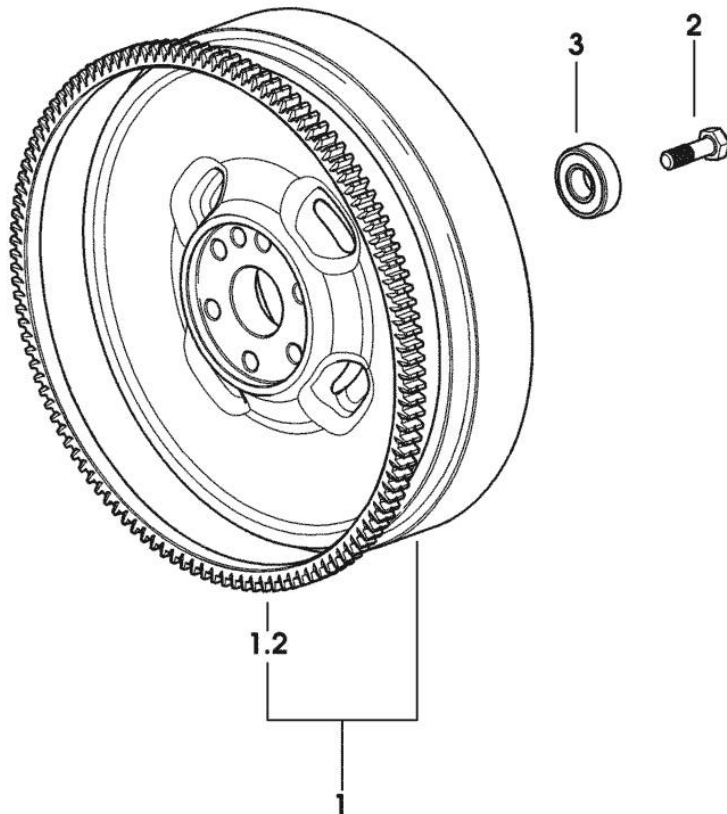

Section: ENGINE

CRANKSHAFT PULLEY

Fig.	P/n	QTY	Name
------	-----	-----	------

Notes:
[ROCK 55 M]

1	0.007.1330.0/40	1	pulley
2	2.1589.189.0	2	shoulder ring mm 1.00
3	0.085.1248.0/20	1	hub
4	2.0399.144.7/10	1	screw m 20 p.1.5x51
6	2.1720.006.0	1	key 4x6.5

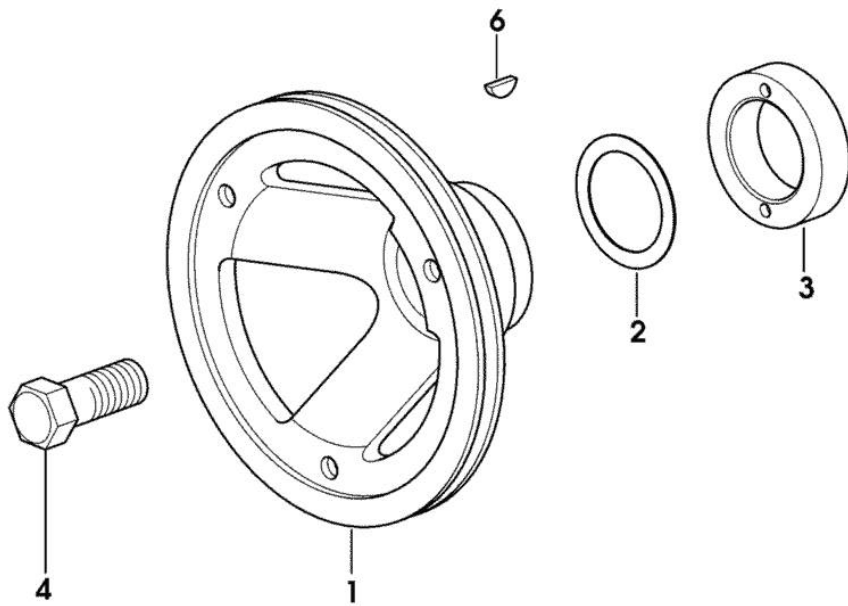

9_33012_02_0_0

Section: ENGINE

CAMSHAFT

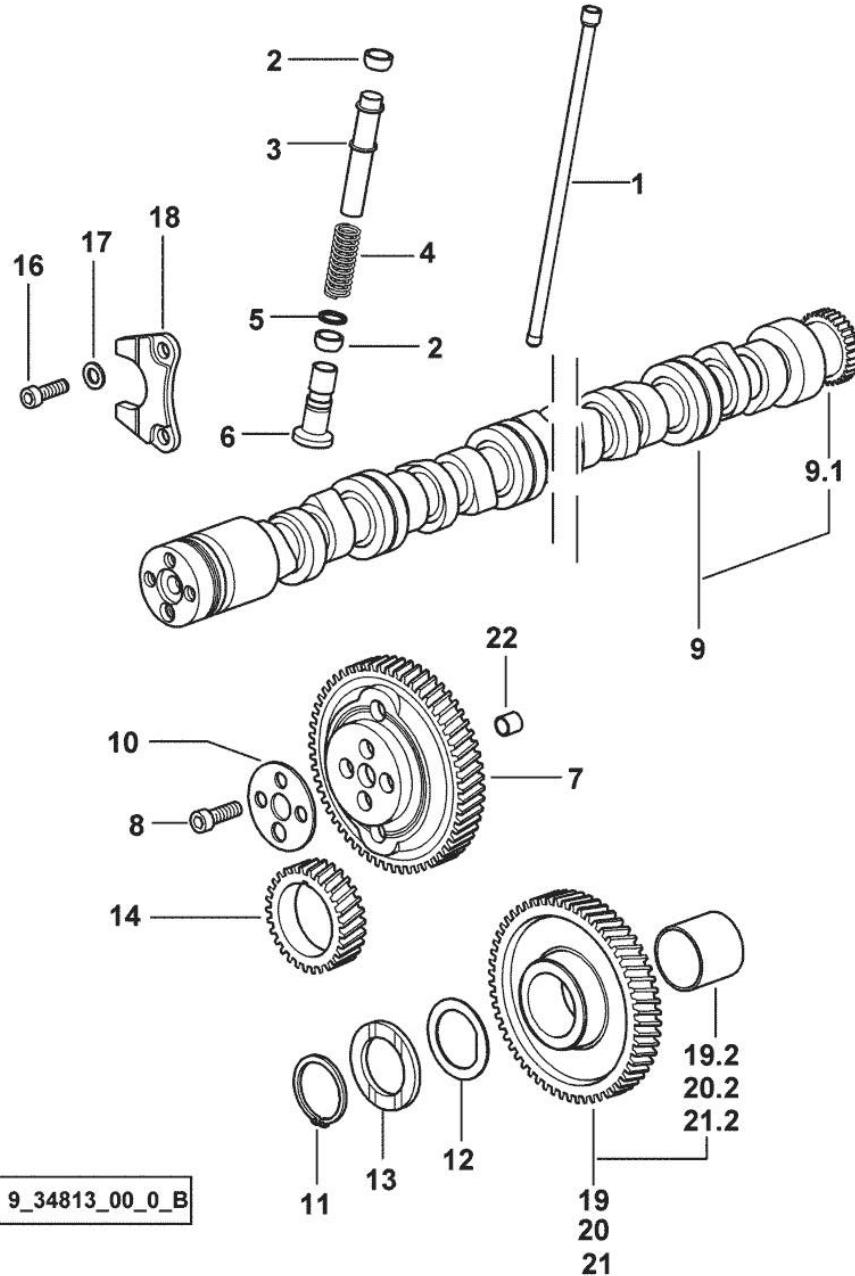

9_34813_00_0_B

Fig.	P/n	QTY	Name
------	-----	-----	------

Notes:

29598 <= X ROCK 55 29600 <= X ROCK 60 [ROCK 55 M]

1	0.065.1331.2	6	rod
2	2.1569.114.0/10	12	gasket 14x18.5x8
3	0.065.1332.0	6	sleeve
4	2.4019.300.1/10	6	spring 18.5x52x2
5	2.1599.437.0	6	shoulder ring
6	0.065.1330.0	6	tappets
7	0.013.5017.0	1	gear z=58
8	2.0132.207.2	4	screw m 10 p.1 x 25
9	0.070.1310.3/40	1	camshaft
9.1	0.065.1324.0/10	1	gear Z = 32
10	0.065.1350.0	1	small disc
11	2.1410.016.1	1	circlip 40
12	0.065.1352.0	1	shim
13	0.065.1351.0	2	shoulder ring
14	0.065.1323.0/30	1	gear Z = 29
16	2.0312.205.2	2	screw
17	2.1480.014.1	2	washer 8
18	0.065.1353.0	1	small plate
19	0.007.1177.3/20		gear z = 57 - WITH RED IDENTIFICATION STAMP
19.2	2.1559.185.0/10	1	bushing gear z = 57
20	0.007.1178.3/20		- WITH YELLOW IDENTIFICATION STAMP
20.2	2.1559.185.0/10	1	bushing
21	0.007.1179.3/20		gear z = 57 - WITH GREEN IDENTIFICATION STAMP
21.2	2.1559.185.0/10	1	bushing
22	2.1559.398.0	1	bushing 10.5x13x12

Section: ENGINE

CAMSHAFT

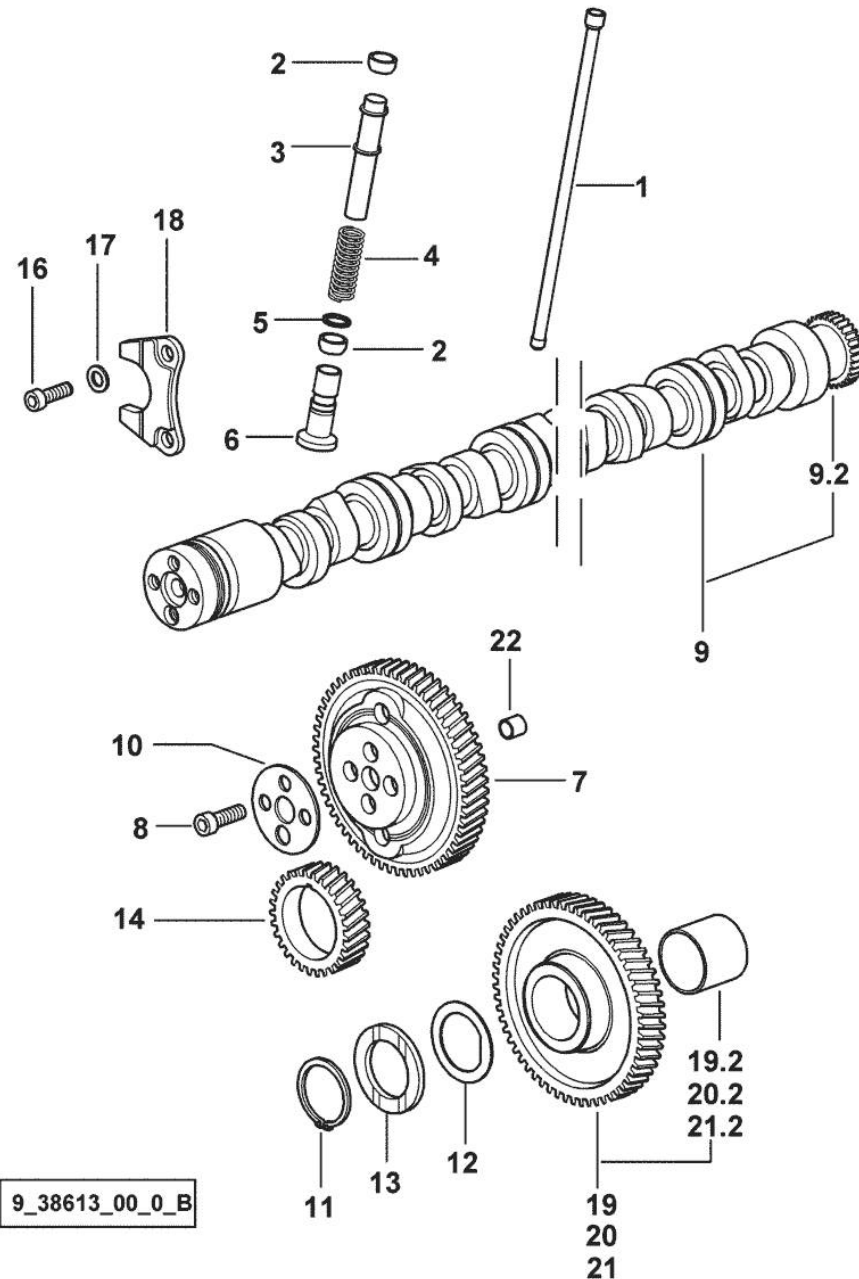

9_38613_00_0_B

Fig.	P/n	QTY	Name
------	-----	-----	------

Notes:

=> 29599 X ROCK 55 => 29601 X ROCK 60 [ROCK 55 M]

1	0.065.1331.2	6	rod
2	2.1569.114.0/10	12	gasket 14x18.5x8
3	0.065.1332.0	6	sleeve
4	2.4019.300.1/10	6	spring 18.5x52x2
5	2.1599.437.0	6	shoulder ring
6	0.065.1330.0	6	tappets
7	0.013.5017.0	1	gear z=58
8	2.0132.207.2	4	screw m 10 p.1 x 25
9	0.009.7456.3/10	1	camshaft
9.2	0.065.1324.0/10	1	gear Z = 32
10	0.065.1350.0	1	small disc
11	2.1410.016.1	1	circlip 40
12	0.065.1352.0	1	shim
13	0.065.1351.0	2	shoulder ring
14	0.065.1323.0/30	1	gear Z = 29
16	2.0312.205.2	2	screw
17	2.1480.014.1	2	washer 8
18	0.065.1353.0	1	small plate
19	0.007.1177.3/20		gear z = 57
			- WITH RED IDENTIFICATION STAMP
19.2	2.1559.185.0/10	1	bushing
20	0.007.1178.3/20		gear z = 57
			- WITH YELLOW IDENTIFICATION STAMP
20.2	2.1559.185.0/10	1	bushing
21	0.007.1179.3/20		gear z = 57
			- WITH GREEN IDENTIFICATION STAMP
21.2	2.1559.185.0/10	1	bushing
22	2.1559.398.0	1	bushing 10.5x13x12

Section: ENGINE
CYLINDER HEAD

9_34814_00_0_0

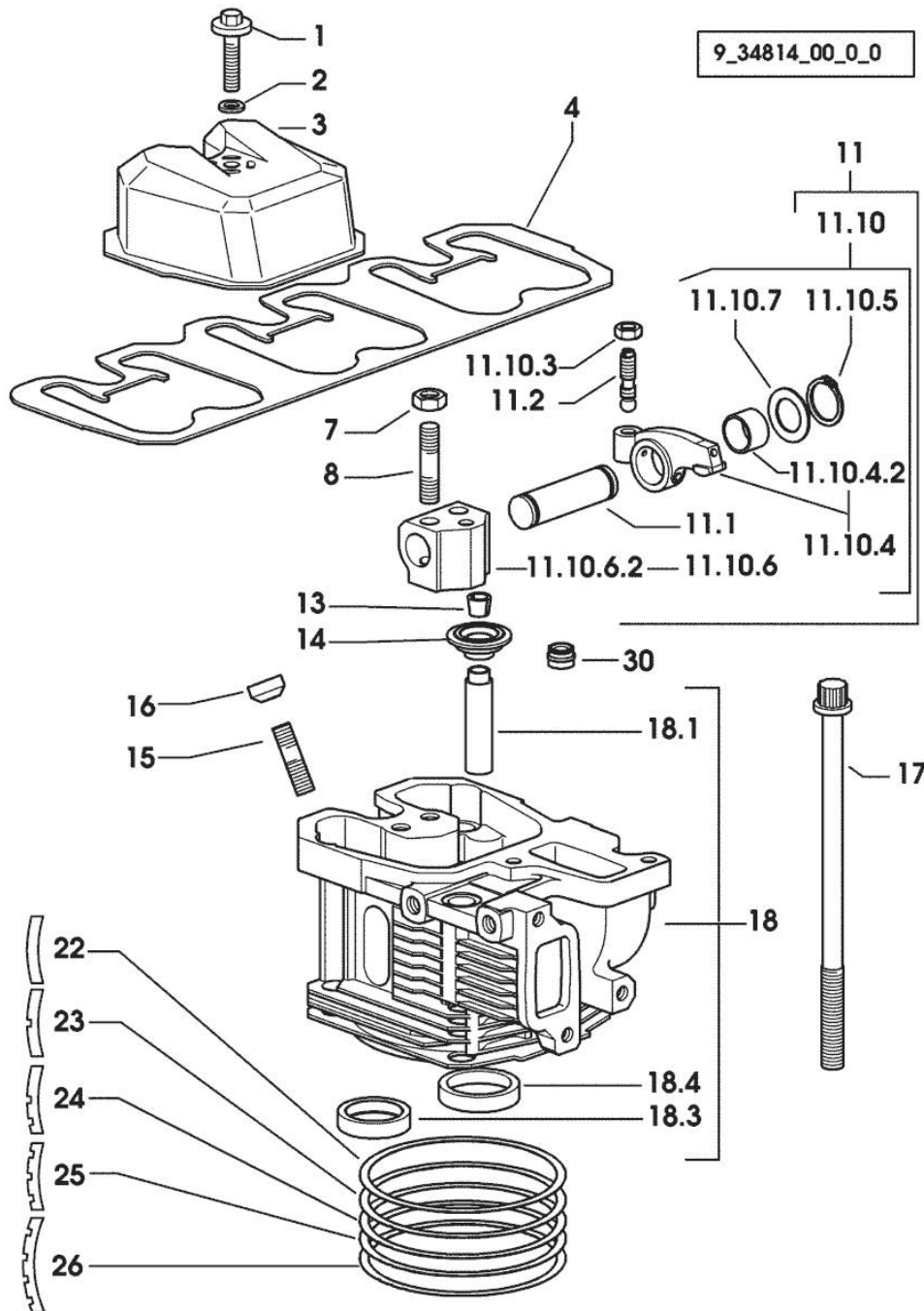

Fig.	P/n	QTY	Name
Notes: [ROCK 55 M]			
1	2.0399.130.2/10	3	screw m 8x36x44 1337 <- X ROCK 55 1393 <- X ROCK 60
1	2.0399.288.2/10	3	screw m 8x36x46 -> 1338 X ROCK 55 -> 1394 X ROCK 60
2	2.1539.151.0	3	special oil seal 9.19 x 2.62 -> 1338 X ROCK 55 -> 1394 X ROCK 60
2	2.1569.170.0/10	3	gasket 8.2 x 14 1337 <- X ROCK 55 1393 <- X ROCK 60
3	0.007.1139.0/10	3	small cap
4	0.069.1450.0/30	1	tappet gasket
7	2.1011.421.2	6	nut m 10 p.1.25
8	2.0432.163.7	6	stud bolt m 10 p.1.5 / p.1.25 x 45
11	0.000.0000.1		cannot be supplied
11.1	0.066.1431.0	1	pin
11.2	0.021.1434.0	2	screw
11.10	0.000.0000.1		cannot be supplied
11.10.3	2.1011.405.2	2	nut m 8 p.1
11.10.4	0.066.1432.3	2	rocker arm
11.10.4.2	2.1559.021.0/40	1	bushing 15x19x22
11.10.5	2.1410.055.7	2	circlip 19
11.10.6	0.000.0000.1		cannot be supplied
11.10.6.2	0.066.1430.0/10	1	support
11.10.7	2.1599.432.0	2	shoulder ring
13	0.074.1423.0	12	conical valve cotter
14	0.066.1425.0	6	cup
15	2.0432.161.7	3	stud bolt m 10 p.1.5 / p.1.25 x 40
16	0.007.1122.0/10	3	bush L = mm 6.4
17	0.065.1443.0/20	12	screw
18	0.007.1110.3/60	3	engine head
18.1	0.007.1779.0/20	2	valve guide
18.3	0.066.1427.0	1	valve seat
18.4	0.078.1426.0	1	valve seat
22	0.085.1450.0/10		head gasket mm 0.50
23	0.085.1451.0/10	3	head gasket mm 0.7
24	0.085.1452.0/10	1	head gasket mm 1.0
25	0.085.1453.0/10	1	head gasket mm 0.8
26	0.013.4598.0	3	head gasket mm 1.3

Section: ENGINE
CYLINDER HEAD

9_34814_00_0_0

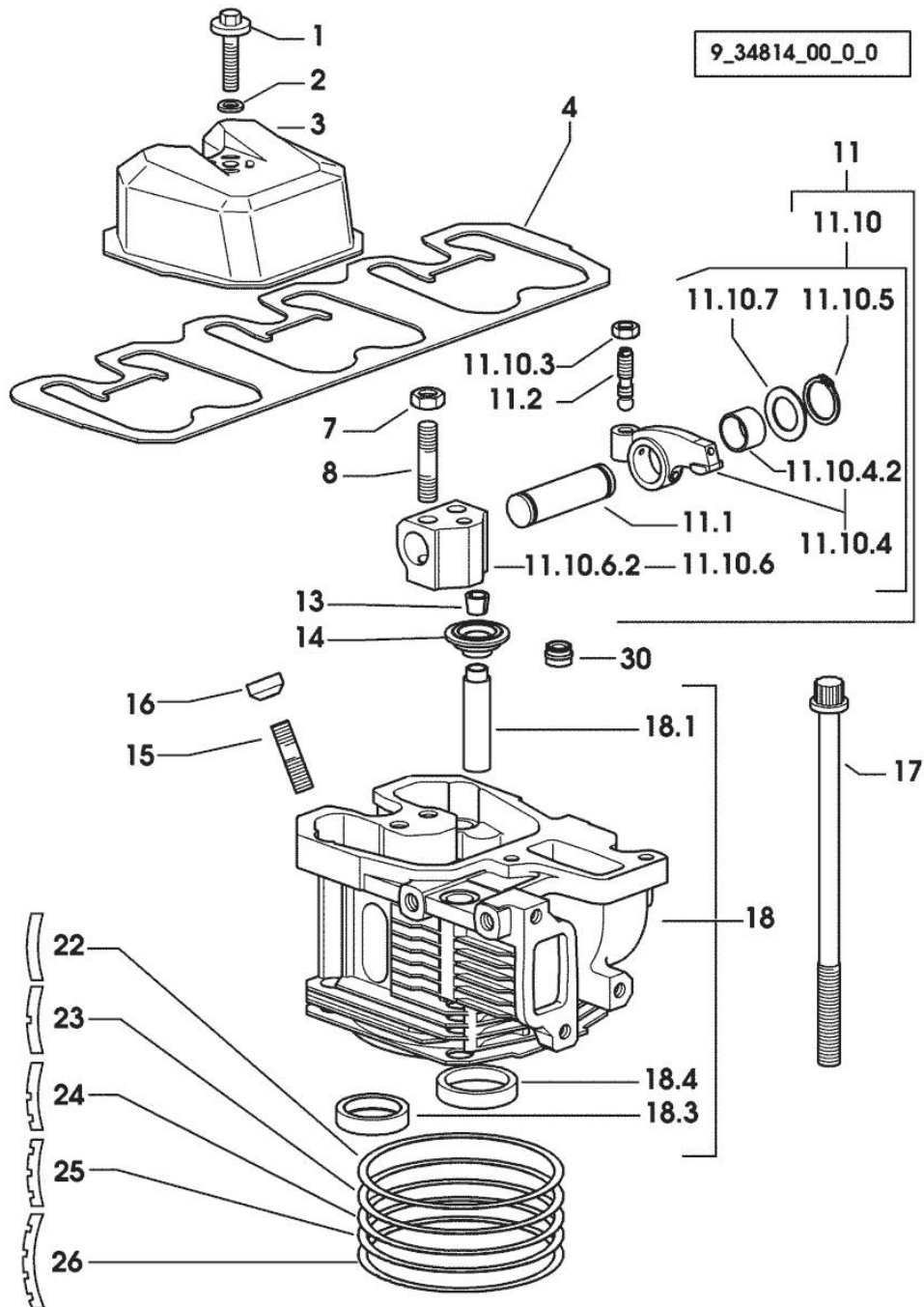

Fig.	P/n	QTY	Name
30	2.1519.117.0	6	special oil seal

INLET AND EXHAUST VALVES

Fig.	P/n	QTY	Name
------	-----	-----	------

Notes:
[ROCK 55 M]

30	0.066.1421.0	3	exhaust valve
31	0.010.6016.0	3	inlet valve mm 43.63 / Ø mm 9

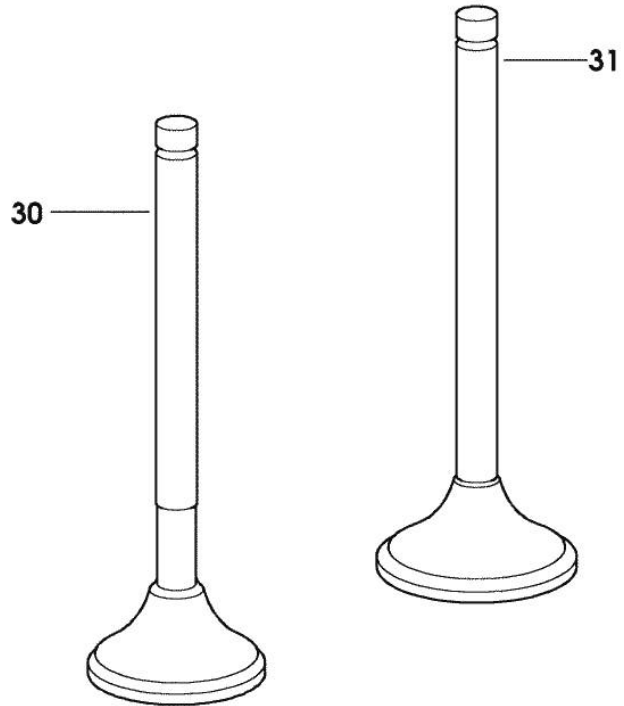

9_34814_02_0_0

INLET AND EXHAUST VALVE SPRINGS

Fig.	P/n	QTY	Name
------	-----	-----	------

Notes:
[ROCK 55 M]

25	2.4019.287.0	6	spring
----	--------------	---	--------

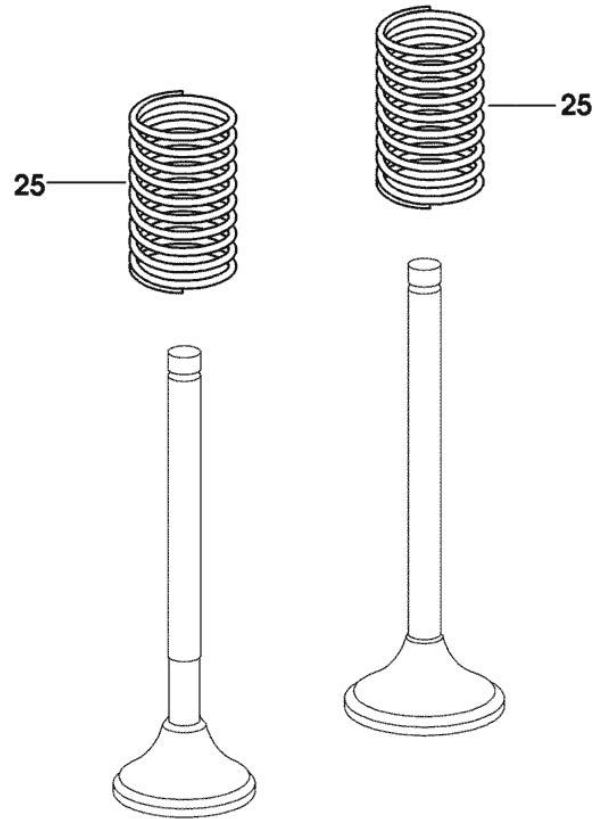

9_34814_01_0_0

Thank you so much for reading.
Please click the “Buy Now!”
button below to download the
complete manual.



After you pay.

You can download the most
perfect and complete manual in
the world immediately.

Our support email:

ebooklibonline@outlook.com