

Section: ENGINE
CRANKCASE

9_34811_00_0_A

| Fig. | P/n | QTY | Name |
|------|-----|-----|------|
|------|-----|-----|------|

Notes:
 [ROCK 60 M]

| | | | |
|----------|-----------------|---|---------------------------------|
| 1 | 0.007.1150.6/10 | 1 | crankcase |
| 1.1 | 2.3130.001.1 | 9 | plug 1/8" gas |
| 1.2 | 2.3130.002.1 | 2 | plug 1/4" gas |
| 1.3 | 2.3130.003.1 | 7 | plug 3/8" gas |
| 1.4 | 2.1324.011.0 | 1 | plug |
| 1.5 | 2.3199.092.0 | 3 | plug 8 x 12 |
| 1.6 | 2.3179.012.0 | 1 | plug 60 |
| 1.12 | 0.000.0000.1 | | cannot be supplied |
| 1.12.1 | 0.065.1112.7 | 1 | support |
| 1.12.1.2 | 2.1699.165.0 | 1 | bush 12.3x15x16 |
| 1.12.2 | 0.065.1114.0/10 | 2 | support |
| 1.12.3 | 0.065.1116.3 | 1 | support |
| 1.12.3.2 | 2.1699.165.0 | 1 | bush 12.3x15x16 |
| 1.12.4 | 0.065.1117.0 | 8 | screw m 12 x 100 |
| 1.12.6 | 0.066.1151.0 | 1 | pin |
| 1.12.7 | 0.065.1141.0 | 1 | special bushing 59X55X30 |
| 1.12.8 | 0.065.1140.0 | 3 | special bushing 59X55X20 |
| 2 | 2.1539.130.0/10 | 3 | special oil seal 117.07x3.53 |
| 4 | 2.0432.003.7 | 9 | stud bolt m 8 p.1.25 / p.1 x 20 |
| 5 | 2.1532.072.0 | 1 | oil seal 26.70x1.78 |
| 6 | 2.3199.405.2 | 1 | plug m 28 p.1.5 |
| 7 | 0.066.1152.0/10 | 4 | gasket |

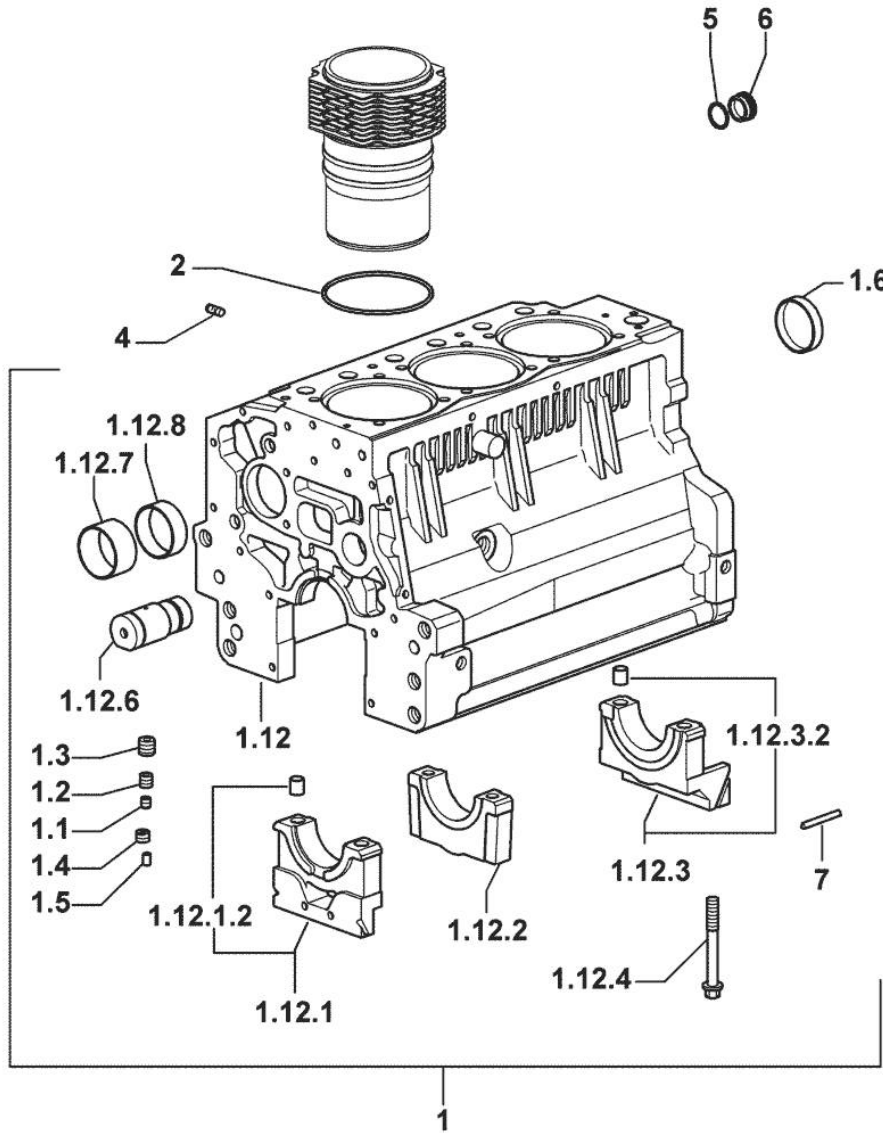

Section: ENGINE
GUARD PLATE

| Fig. | P/n | QTY | Name |
|------|-----|-----|------|
|------|-----|-----|------|

Notes:
 [ROCK 60 M]

| | | | |
|---|-----------------|---|-------------------------------------|
| 1 | 0.007.1262.3/50 | 1 | guard |
| 2 | 0.007.1271.0/10 | 1 | small column m 8 p.1.25 / L = mm 60 |
| 3 | 0.007.1272.0/10 | 2 | small column m 8 p.1.25 / L = mm 50 |
| 5 | 2.1310.004.2 | 3 | flat washer 8.4x17 |
| 7 | 2.0112.203.2 | 3 | screw m 8 p.1.25 x 12 |

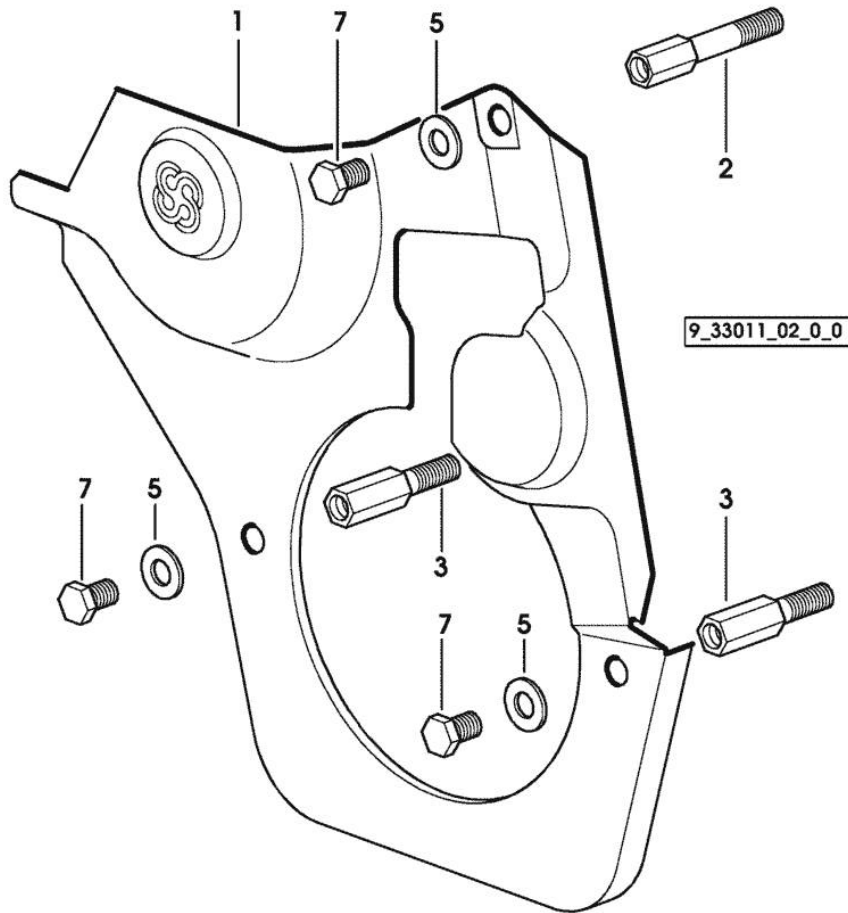

TIMING CASE

9_34811_00_0_B

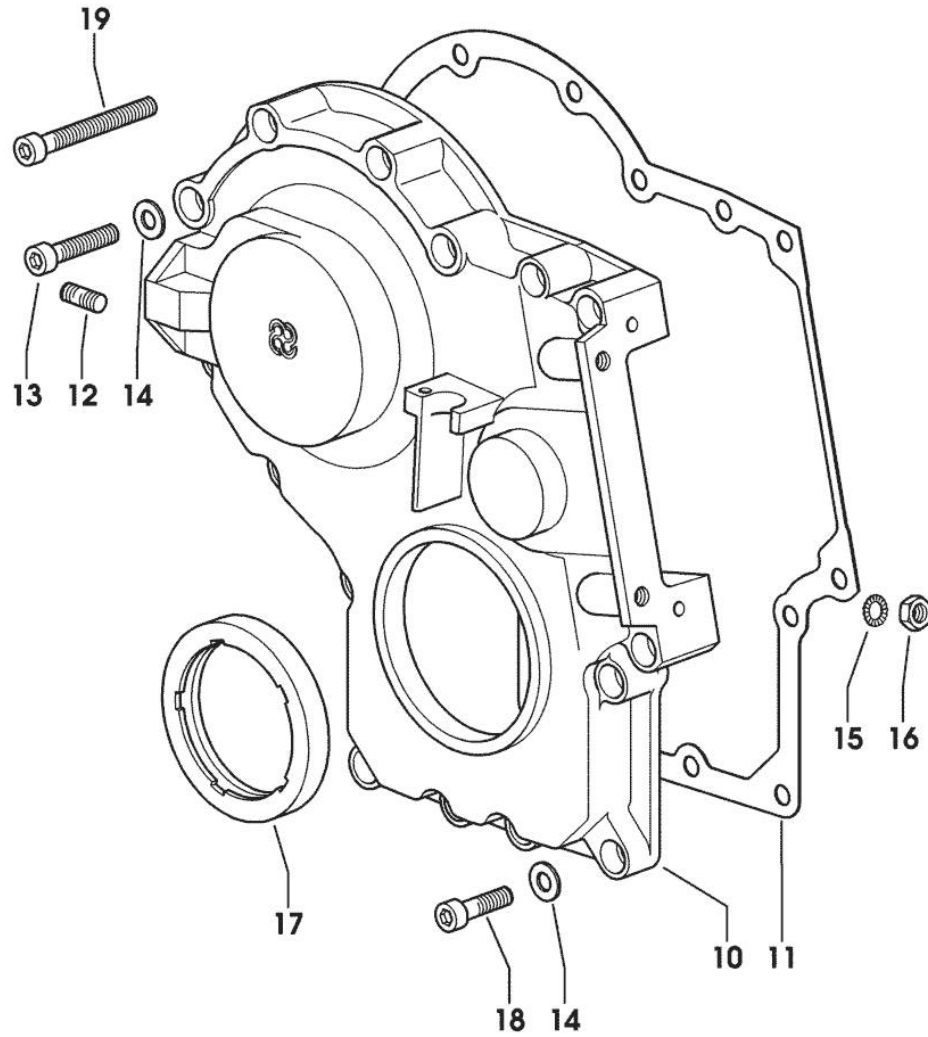

| Fig. | P/n | QTY | Name |
|---------------|-----------------|-----|---|
| Notes: | | | |
| [ROCK 60 M] | | | |
| 10 | 0.013.4981.0 | 1 | guard -> 1155 X ROCK 55 -> 1187 X ROCK 60 |
| 10 | 0.065.1132.0/50 | 1 | guard 1154 <- X ROCK 55 1186 <- X ROCK 60 |
| 11 | 0.065.1150.0/30 | 1 | gasket |
| 12 | 2.0432.003.7 | 2 | stud bolt m 8 p.1.25 / p.1 x 20 |
| 13 | 2.0312.214.2 | 3 | screw m 8 p.1.25 x 40 |
| 14 | 2.1480.014.1 | 15 | washer 8 |
| 15 | 2.1470.004.2 | 4 | lock washer 8 |
| 16 | 2.1011.405.2 | 2 | nut m 8 p.1 |
| 17 | 2.1529.167.0 | 1 | oil seal |
| 18 | 2.0312.208.2 | 8 | screw m 8 p.1.25 x 25 |
| 19 | 2.0312.219.2 | 4 | screw m 8 p.1.25x65 |

Section: ENGINE
CRANKCASE

| Fig. | P/n | QTY | Name |
|------|-----|-----|------|
|------|-----|-----|------|

Notes:
 [ROCK 60 M]

| | | | |
|----|-----------------|---|-----------------------------------|
| 6 | 2.0439.250.7 | 1 | stud bolt m 12 / m 10 x 30 |
| 7 | 0.011.9294.0/10 | 1 | bush |
| 30 | 2.0112.511.2 | 8 | screw m 14 p.2 x 30 |
| 31 | 2.1651.912.0 | 2 | cylindrical plug 12x28 |
| 32 | 2.1651.917.0 | 1 | cylindrical plug 12x40 |
| 33 | 2.0432.257.7 | 1 | stud bolt m 12 p.1.75 - 1.25 x 30 |
| 34 | 0.007.9745.0/10 | 1 | flange |

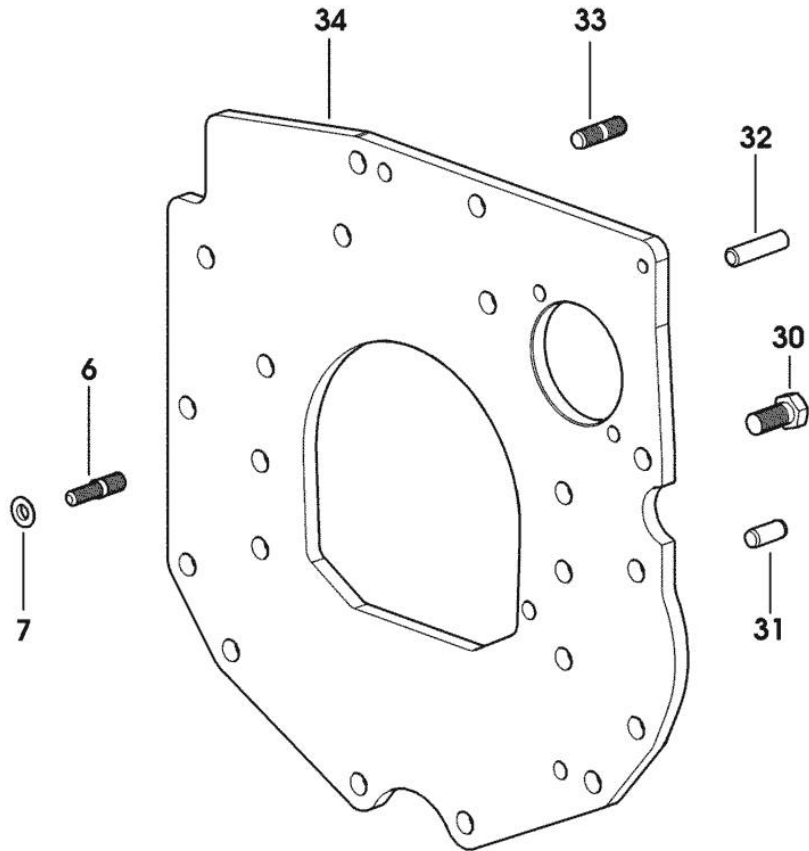

9_33311_02_0_0

Section: ENGINE
CRANKSHAFT

9_34812_00_0_0

| Fig. | P/n | QTY | Name |
|------|-----|-----|------|
|------|-----|-----|------|

Notes:
 [ROCK 60 M]

| | | | |
|----|-----------------|---|-----------------------------|
| 4 | 2.3130.001.1 | 3 | plug 1/8" gas |
| 6 | 2.1720.006.0 | 2 | key 4x6.5 |
| 7 | 0.007.1554.0/20 | 1 | crankshaft |
| 8 | 0.065.1215.0 | 4 | main half bushing STANDARD |
| 8 | 0.065.1215.7 | | main half bushing - mm 0.25 |
| 8 | 0.065.1215.8 | | main half bushing - mm 0.50 |
| 9 | 0.065.1216.0 | 4 | main half bushing |
| 9 | 0.065.1216.7 | | main half bushing - mm 0.25 |
| 9 | 0.065.1216.8 | | main half bushing - mm 0.50 |
| 10 | 0.065.1218.0 | 4 | shim STANDARD |
| 10 | 0.065.1218.7 | | shim + mm 0.10 |
| 10 | 0.065.1218.8 | | shim + mm 0.15 |
| 15 | 0.065.1254.0/20 | 1 | gasket |
| 16 | 0.007.1711.0/10 | 1 | cover |
| 17 | 2.1475.002.2 | 9 | conical washer 8 |
| 18 | 2.0112.207.2 | 9 | screw m 8 p 1.25 x 20 |
| 19 | 2.1529.073.0 | 1 | special oil seal 110x130x13 |
| 20 | 2.1651.915.0 | 1 | pin 12x35 |
| 22 | 2.1599.524.7 | 1 | washer 21x60x12 |

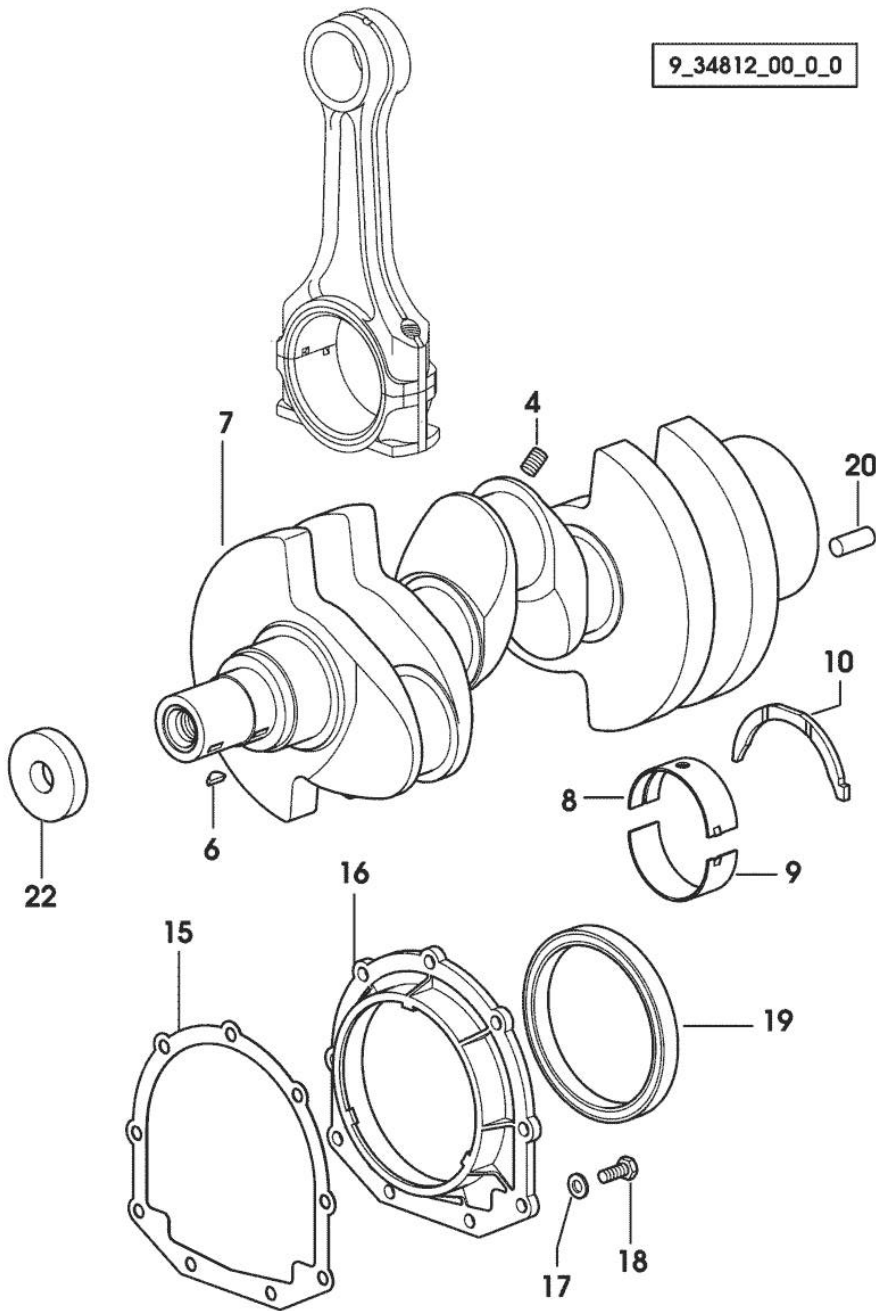

Section: ENGINE

CYLINDER - PISTON - CONNECTING ROD

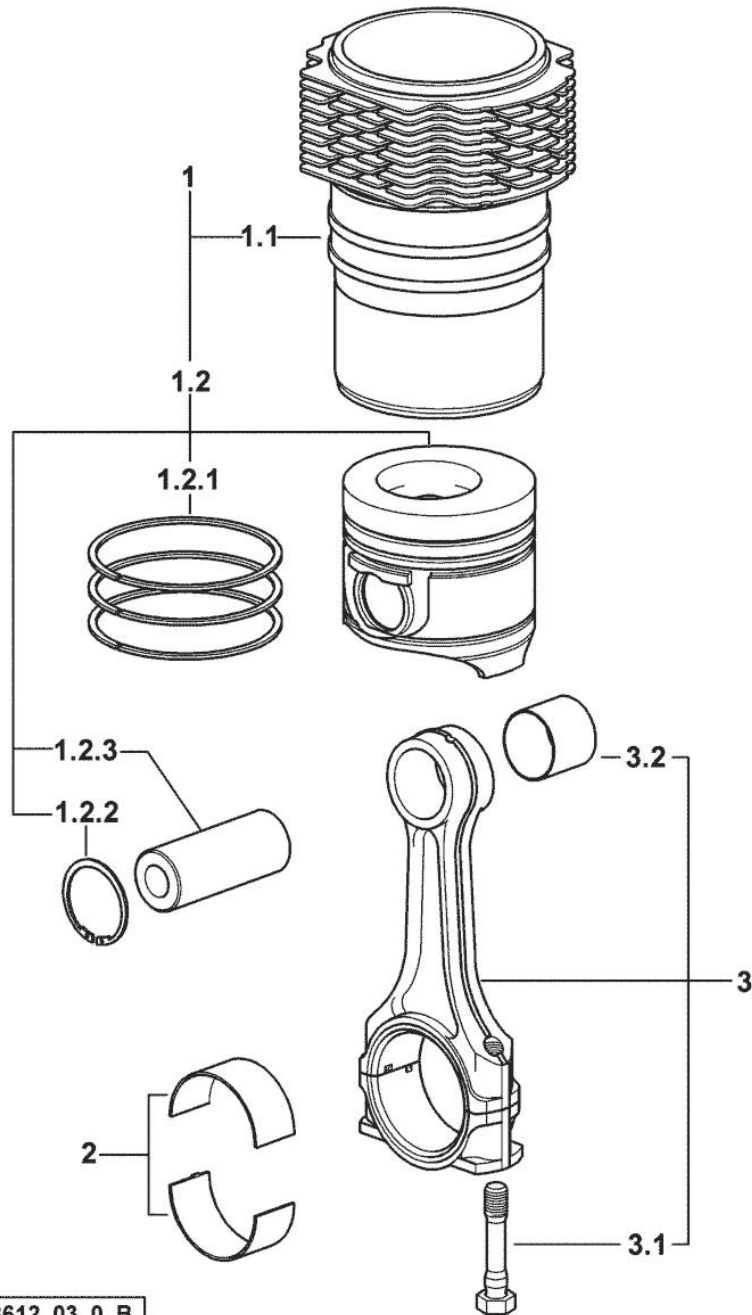

| Fig. | P/n | QTY | Name |
|------|-----|-----|------|
|------|-----|-----|------|

Notes:

29598 <= X ROCK 55 29600 <= X ROCK 60 [ROCK 60 M]

| | | | |
|-------|-----------------|---|--|
| 1 | 0.336.0065.A | 3 | cyl. piston assembly "A" - CLASS A |
| 1 | 0.336.0065.B | 3 | cyl. piston assembly "B" - CLASS B |
| 1.1 | 0.A13.0355.0 | 1 | engine cylinder "A" - CLASS A |
| 1.1 | 0.B13.0355.0 | 1 | engine cylinder "B" - CLASS B |
| 1.2 | 0.086.0060.A | 1 | complete piston "A" - CLASS A |
| 1.2 | 0.086.0060.B | 1 | complete piston "B" - CLASS B |
| 1.2.1 | 0.086.0052.6/10 | 1 | piston ring set |
| 1.2.2 | 2.1411.014.1 | 2 | circlip 35 |
| 1.2.3 | 0.078.1236.0 | 1 | piston pin Ø 18 / Ø 35 / L = mm 86 |
| 2 | 0.065.1225.0 | 6 | con.rod half bushing STANDARD - A = 28.75 -> 29.00 |
| 2 | 0.065.1225.7 | 6 | con.rod half bushing - mm 0.25 |
| 2 | 0.065.1225.8 | 6 | con.rod half bushing - mm 0.50 |
| 3 | 0.078.1220.3/30 | 3 | engine connecting rod |
| 3.1 | 2.0399.213.0 | 2 | screw m 12 p.1.25x61.5 |
| 3.2 | 2.1559.114.0/10 | 1 | special bushing |

CYLINDER - PISTON - CONNECTING ROD

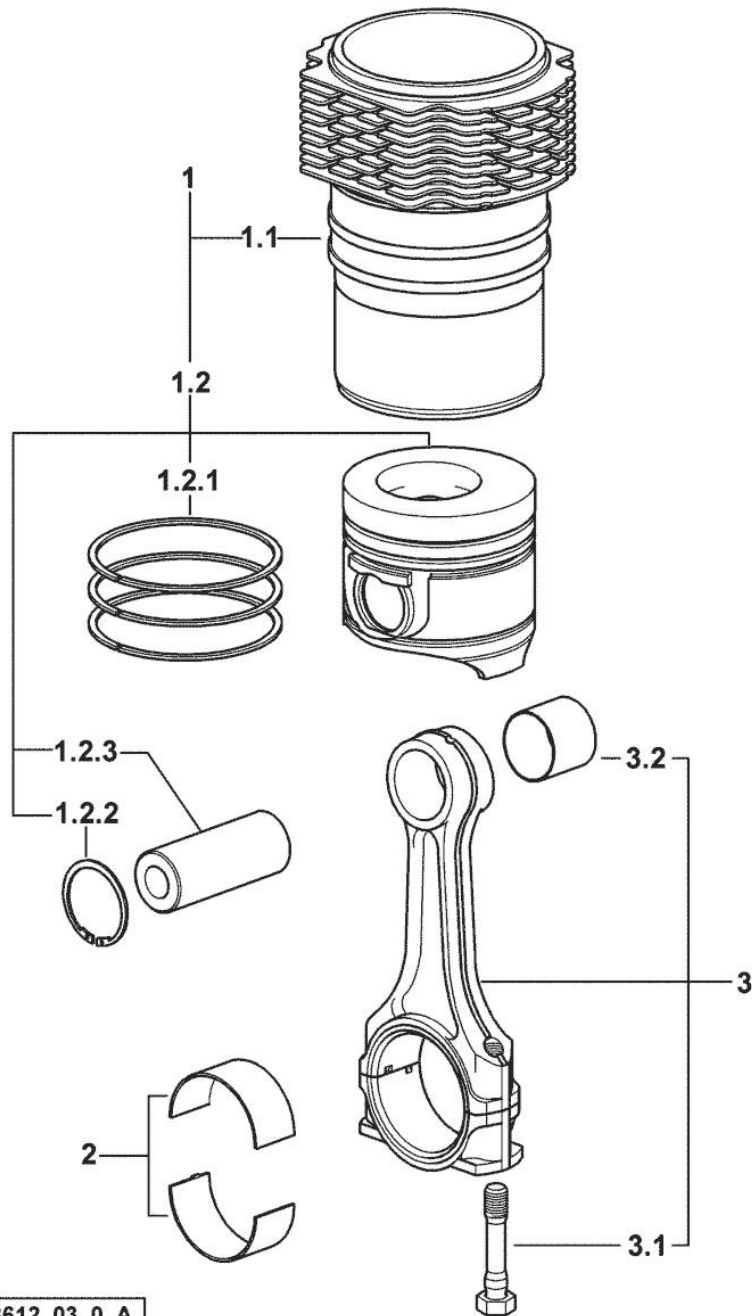

| Fig. | P/n | QTY | Name |
|------|-----|-----|------|
|------|-----|-----|------|

Notes:

=> 29599 X ROCK 55 => 29601 X ROCK 60 [ROCK 60 M]

| | | | |
|-------|-----------------|---|--|
| 1 | 0.379.0065.A | 3 | cyl. piston assembly "A" - CLASS A |
| 1 | 0.379.0065.B | 3 | cyl. piston assembly "B" - CLASS B |
| 1.1 | 0.A13.0355.0 | 1 | engine cylinder "A" - CLASS A |
| 1.1 | 0.B13.0355.0 | 1 | engine cylinder "B" - CLASS B |
| 1.2 | 0.379.0060.A | 1 | complete piston "A" - CLASS A |
| 1.2 | 0.379.0060.B | 1 | complete piston "B" - CLASS B |
| 1.2.1 | 0.086.0052.6/10 | 1 | piston ring set |
| 1.2.2 | 2.1411.014.1 | 2 | circlip 35 |
| 1.2.3 | 0.078.1236.0 | 1 | piston pin Ø 18 / Ø 35 / L = mm 86 |
| 2 | 0.065.1225.0 | 6 | con.rod half bushing STANDARD - A = 28.75 -> 29.00 |
| 2 | 0.065.1225.7 | 6 | con.rod half bushing - mm 0.25 |
| 2 | 0.065.1225.8 | 6 | con.rod half bushing - mm 0.50 |
| 3 | 0.078.1220.3/30 | 3 | engine connecting rod |
| 3.1 | 2.0399.213.0 | 2 | screw m 12 p.1.25x61.5 |
| 3.2 | 2.1559.114.0/10 | 1 | special bushing |

Section: ENGINE

ENGINE FLYWHEEL

| Fig. | P/n | QTY | Name |
|------|-----|-----|------|
|------|-----|-----|------|

Notes:
[ROCK 60 M]

| | | | |
|-----|-----------------|---|-----------------------|
| 1 | 0.007.9652.3/10 | 1 | flywheel |
| 1.2 | 0.069.1242.0 | 1 | crown wheel Z = 121 |
| 2 | 2.0119.174.0/10 | 6 | screw m 12 p.1.25x45 |
| 3 | 2.2041.008.0 | 1 | ball bearing 20x47x14 |

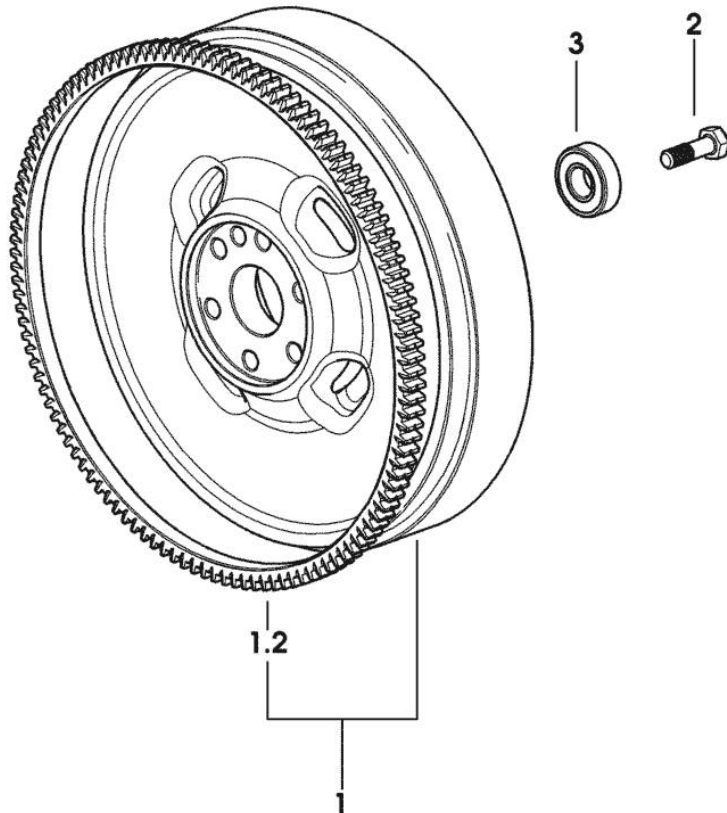

9_34812_03_0_0

Section: ENGINE

CRANKSHAFT PULLEY

| Fig. | P/n | QTY | Name |
|------|-----|-----|------|
|------|-----|-----|------|

Notes:
[ROCK 60 M]

| | | | |
|---|-----------------|---|-----------------------|
| 1 | 0.007.1330.0/40 | 1 | pulley |
| 2 | 2.1589.189.0 | 2 | shoulder ring mm 1.00 |
| 3 | 0.085.1248.0/20 | 1 | hub |
| 4 | 2.0399.144.7/10 | 1 | screw m 20 p.1.5x51 |
| 6 | 2.1720.006.0 | 1 | key 4x6.5 |

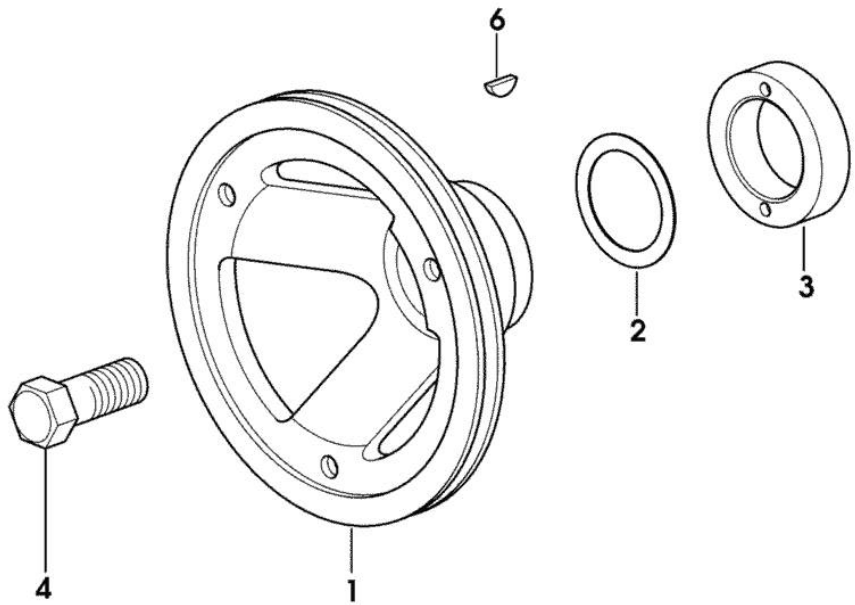

9_33012_02_0_0

Section: ENGINE

CAMSHAFT

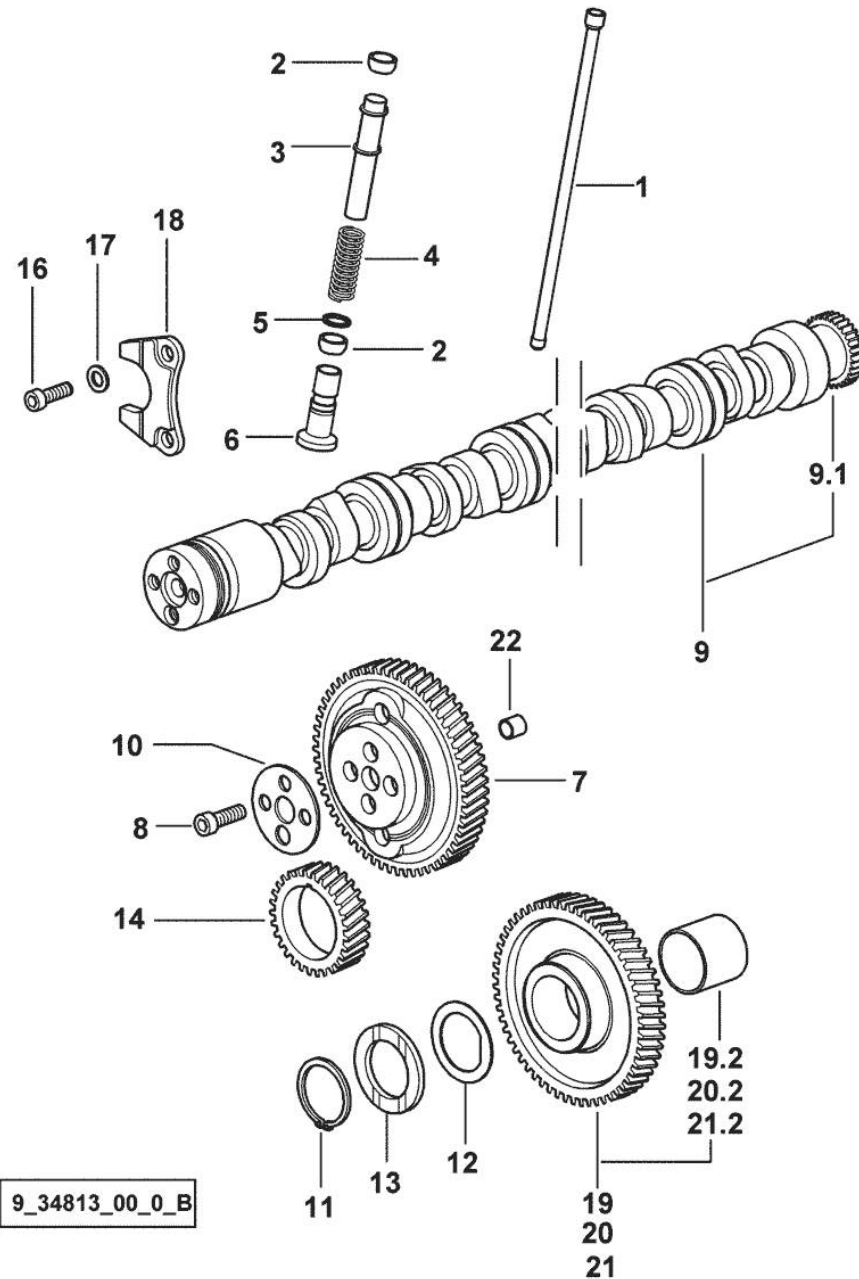

9_34813_00_0_B

| Fig. | P/n | QTY | Name |
|------|-----|-----|------|
|------|-----|-----|------|

Notes:

29598 <= X ROCK 55 29600 <= X ROCK 60 [ROCK 60 M]

| | | | |
|------|-----------------|----|---|
| 1 | 0.065.1331.2 | 6 | rod |
| 2 | 2.1569.114.0/10 | 12 | gasket 14x18.5x8 |
| 3 | 0.065.1332.0 | 6 | sleeve |
| 4 | 2.4019.300.1/10 | 6 | spring 18.5x52x2 |
| 5 | 2.1599.437.0 | 6 | shoulder ring |
| 6 | 0.065.1330.0 | 6 | tappets |
| 7 | 0.013.5017.0 | 1 | gear z=58 |
| 8 | 2.0132.207.2 | 4 | screw m 10 p.1 x 25 |
| 9 | 0.070.1310.3/40 | 1 | camshaft |
| 9.1 | 0.065.1324.0/10 | 1 | gear Z = 32 |
| 10 | 0.065.1350.0 | 1 | small disc |
| 11 | 2.1410.016.1 | 1 | circlip 40 |
| 12 | 0.065.1352.0 | 1 | shim |
| 13 | 0.065.1351.0 | 2 | shoulder ring |
| 14 | 0.065.1323.0/30 | 1 | gear Z = 29 |
| 16 | 2.0312.205.2 | 2 | screw |
| 17 | 2.1480.014.1 | 2 | washer 8 |
| 18 | 0.065.1353.0 | 1 | small plate |
| 19 | 0.007.1177.3/20 | | gear z = 57 - WITH RED IDENTIFICATION STAMP |
| 19.2 | 2.1559.185.0/10 | 1 | bushing |
| 20 | 0.007.1178.3/20 | | gear z = 57 - WITH YELLOW IDENTIFICATION STAMP |
| 20.2 | 2.1559.185.0/10 | 1 | bushing |
| 21 | 0.007.1179.3/20 | | gear z = 57 - WITH GREEN IDENTIFICATION STAMP |
| 21.2 | 2.1559.185.0/10 | 1 | bushing |
| 22 | 2.1559.398.0 | 1 | bushing 10.5x13x12 |

Section: ENGINE

CAMSHAFT

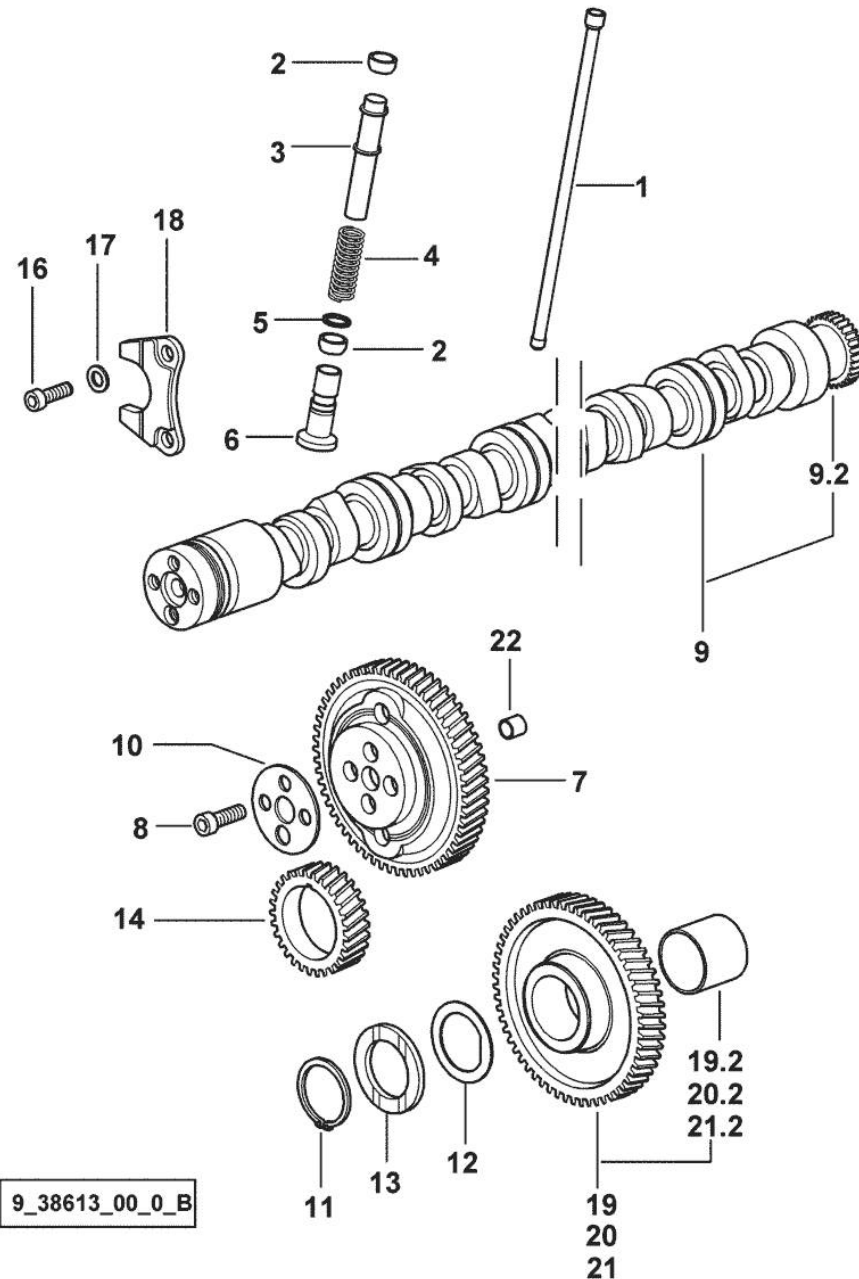

9_38613_00_0_B

| Fig. | P/n | QTY | Name |
|------|-----|-----|------|
|------|-----|-----|------|

Notes:

=> 29599 X ROCK 55 => 29601 X ROCK 60 [ROCK 60 M]

| | | | |
|------|-----------------|----|------------------------------------|
| 1 | 0.065.1331.2 | 6 | rod |
| 2 | 2.1569.114.0/10 | 12 | gasket 14x18.5x8 |
| 3 | 0.065.1332.0 | 6 | sleeve |
| 4 | 2.4019.300.1/10 | 6 | spring 18.5x52x2 |
| 5 | 2.1599.437.0 | 6 | shoulder ring |
| 6 | 0.065.1330.0 | 6 | tappets |
| 7 | 0.013.5017.0 | 1 | gear z=58 |
| 8 | 2.0132.207.2 | 4 | screw m 10 p.1 x 25 |
| 9 | 0.009.7456.3/10 | 1 | camshaft |
| 9.2 | 0.065.1324.0/10 | 1 | gear Z = 32 |
| 10 | 0.065.1350.0 | 1 | small disc |
| 11 | 2.1410.016.1 | 1 | circlip 40 |
| 12 | 0.065.1352.0 | 1 | shim |
| 13 | 0.065.1351.0 | 2 | shoulder ring |
| 14 | 0.065.1323.0/30 | 1 | gear Z = 29 |
| 16 | 2.0312.205.2 | 2 | screw |
| 17 | 2.1480.014.1 | 2 | washer 8 |
| 18 | 0.065.1353.0 | 1 | small plate |
| 19 | 0.007.1177.3/20 | | gear z = 57 |
| | | | - WITH RED IDENTIFICATION STAMP |
| 19.2 | 2.1559.185.0/10 | 1 | bushing |
| 20 | 0.007.1178.3/20 | | gear z = 57 |
| | | | - WITH YELLOW IDENTIFICATION STAMP |
| 20.2 | 2.1559.185.0/10 | 1 | bushing |
| 21 | 0.007.1179.3/20 | | gear z = 57 |
| | | | - WITH GREEN IDENTIFICATION STAMP |
| 21.2 | 2.1559.185.0/10 | 1 | bushing |
| 22 | 2.1559.398.0 | 1 | bushing 10.5x13x12 |

Section: ENGINE
CYLINDER HEAD

9_34814_00_0_0

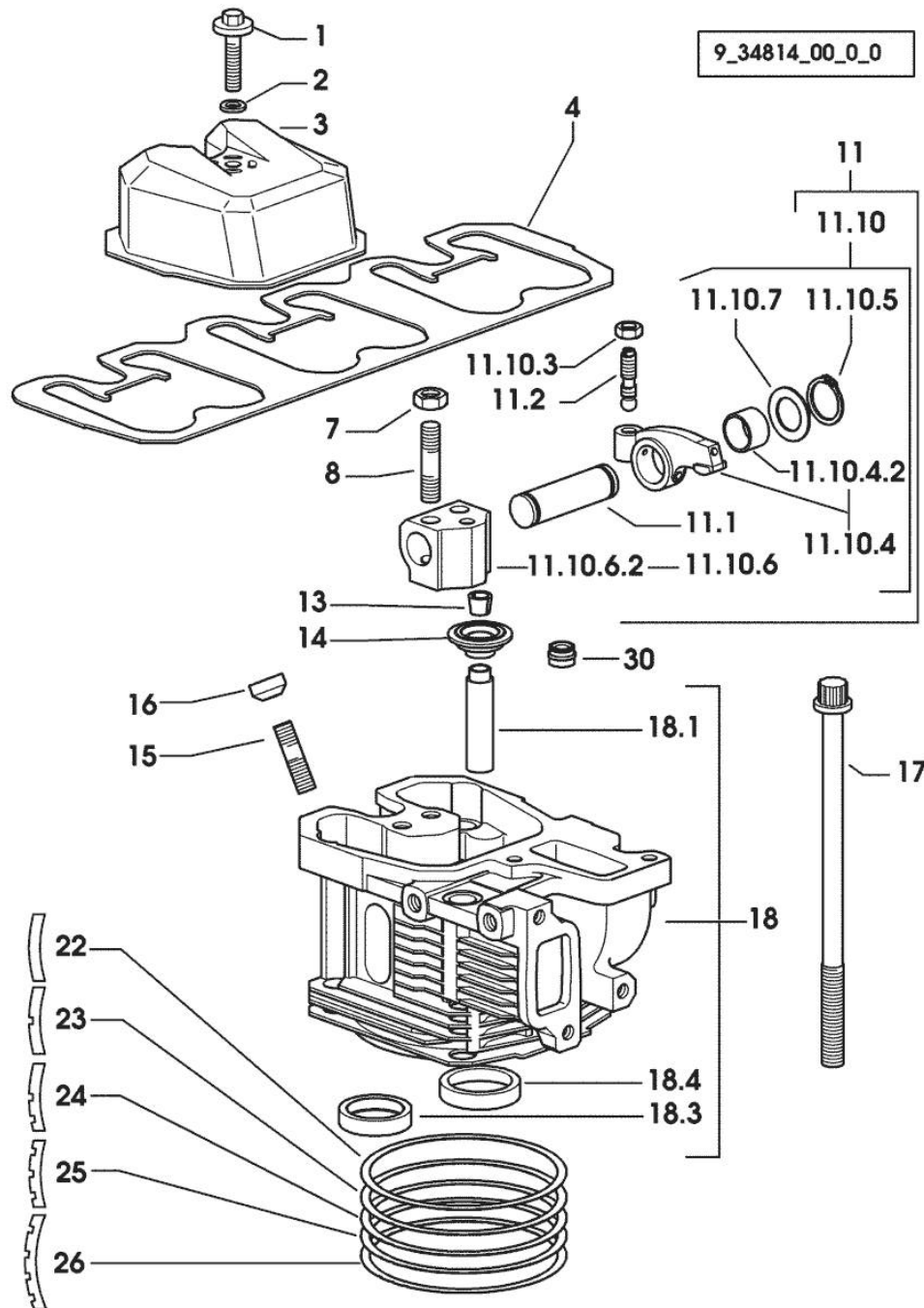

| Fig. | P/n | QTY | Name |
|------------------------------|-----------------|-----|--|
| Notes: [ROCK 60 M] | | | |
| 1 | 2.0399.130.2/10 | 3 | screw m 8x36x44 1337 <- X ROCK 55 1393 <- X ROCK 60 |
| 1 | 2.0399.288.2/10 | 3 | screw m 8x36x46 -> 1338 X ROCK 55 -> 1394 X ROCK 60 |
| 2 | 2.1539.151.0 | 3 | special oil seal 9.19 x 2.62 -> 1338 X ROCK 55 -> 1394 X ROCK 60 |
| 2 | 2.1569.170.0/10 | 3 | gasket 8.2 x 14 1337 <- X ROCK 55 1393 <- X ROCK 60 |
| 3 | 0.007.1139.0/10 | 3 | small cap |
| 4 | 0.069.1450.0/30 | 1 | tappet gasket |
| 7 | 2.1011.421.2 | 6 | nut m 10 p.1.25 |
| 8 | 2.0432.163.7 | 6 | stud bolt m 10 p.1.5 / p.1.25 x 45 |
| 11 | 0.000.0000.1 | | cannot be supplied |
| 11.1 | 0.066.1431.0 | 1 | pin |
| 11.2 | 0.021.1434.0 | 2 | screw |
| 11.10 | 0.000.0000.1 | | cannot be supplied |
| 11.10.3 | 2.1011.405.2 | 2 | nut m 8 p.1 |
| 11.10.4 | 0.066.1432.3 | 2 | rocker arm |
| 11.10.4.2 | 2.1559.021.0/40 | 1 | bushing 15x19x22 |
| 11.10.5 | 2.1410.055.7 | 2 | circlip 19 |
| 11.10.6 | 0.000.0000.1 | | cannot be supplied |
| 11.10.6.2 | 0.066.1430.0/10 | 1 | support |
| 11.10.7 | 2.1599.432.0 | 2 | shoulder ring |
| 13 | 0.074.1423.0 | 12 | conical valve cotter |
| 14 | 0.066.1425.0 | 6 | cup |
| 15 | 2.0432.161.7 | 3 | stud bolt m 10 p.1.5 / p.1.25 x 40 |
| 16 | 0.007.1122.0/10 | 3 | bush L = mm 6.4 |
| 17 | 0.065.1443.0/20 | 12 | screw |
| 18 | 0.007.1110.3/60 | 3 | engine head |
| 18.1 | 0.007.1779.0/20 | 2 | valve guide |
| 18.3 | 0.066.1427.0 | 1 | valve seat |
| 18.4 | 0.078.1426.0 | 1 | valve seat |
| 22 | 0.085.1450.0/10 | | head gasket mm 0.50 |
| 23 | 0.085.1451.0/10 | 3 | head gasket mm 0.7 |
| 24 | 0.085.1452.0/10 | 1 | head gasket mm 1.0 |
| 25 | 0.085.1453.0/10 | 1 | head gasket mm 0.8 |
| 26 | 0.013.4598.0 | 3 | head gasket mm 1.3 |

Section: ENGINE
CYLINDER HEAD

9_34814_00_0_0

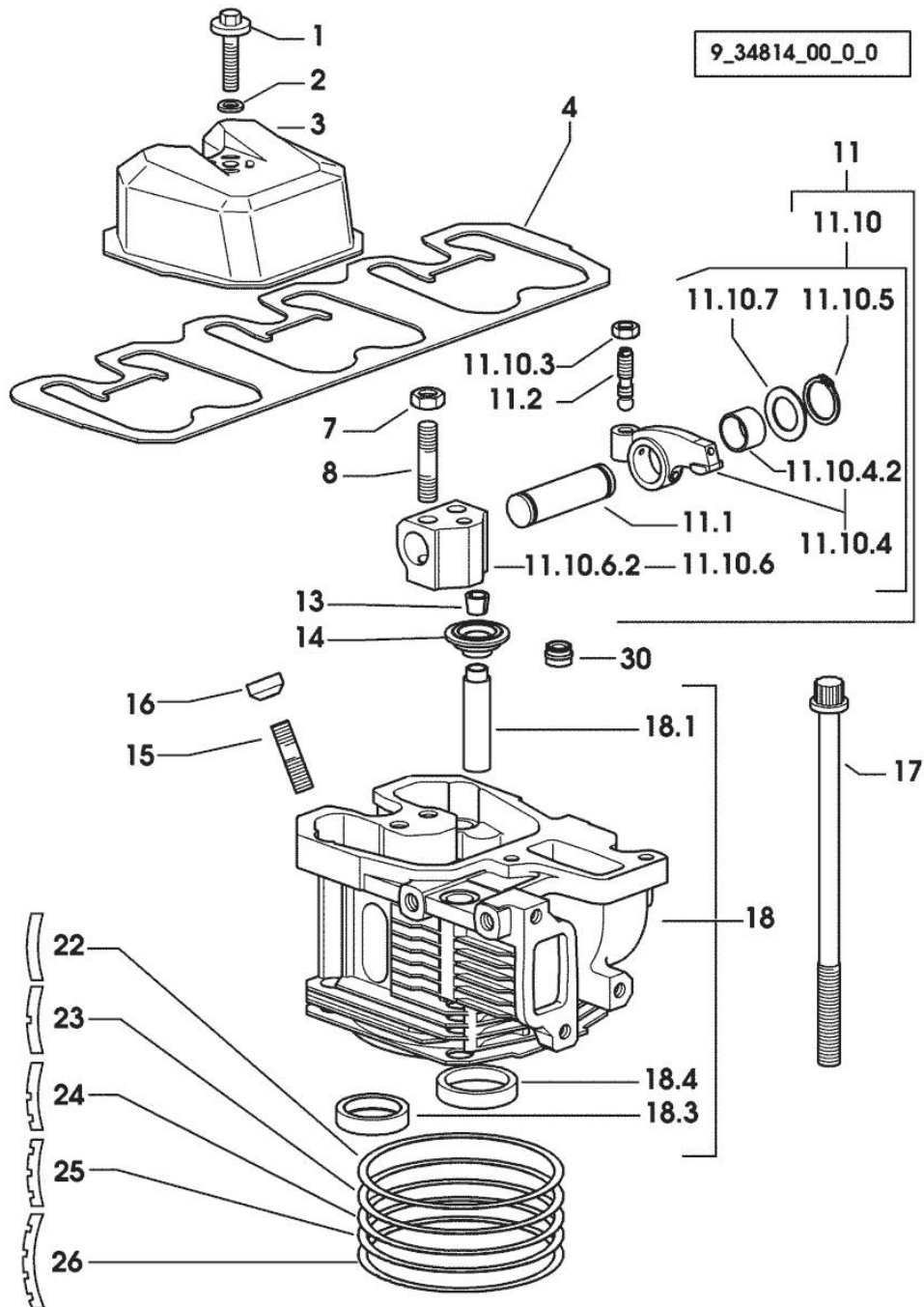

| Fig. | P/n | QTY | Name |
|------|--------------|-----|------------------|
| 30 | 2.1519.117.0 | 6 | special oil seal |

INLET AND EXHAUST VALVES

| Fig. | P/n | QTY | Name |
|------|-----|-----|------|
|------|-----|-----|------|

Notes:
[ROCK 60 M]

| | | | |
|----|--------------|---|-------------------------------|
| 30 | 0.066.1421.0 | 3 | exhaust valve |
| 31 | 0.010.6016.0 | 3 | inlet valve mm 43.63 / Ø mm 9 |

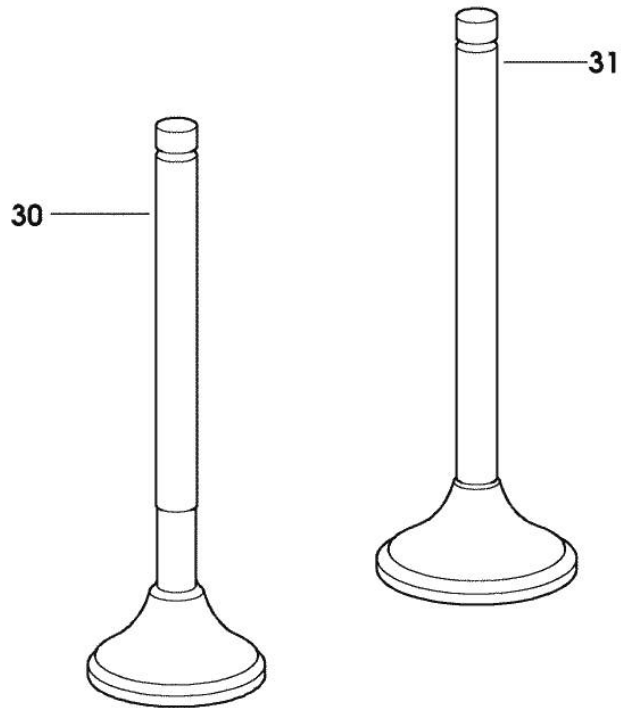

9_34814_02_0_0

INLET AND EXHAUST VALVE SPRINGS

| Fig. | P/n | QTY | Name |
|------|-----|-----|------|
|------|-----|-----|------|

Notes:
[ROCK 60 M]

| | | | |
|----|--------------|---|--------|
| 25 | 2.4019.287.0 | 6 | spring |
|----|--------------|---|--------|

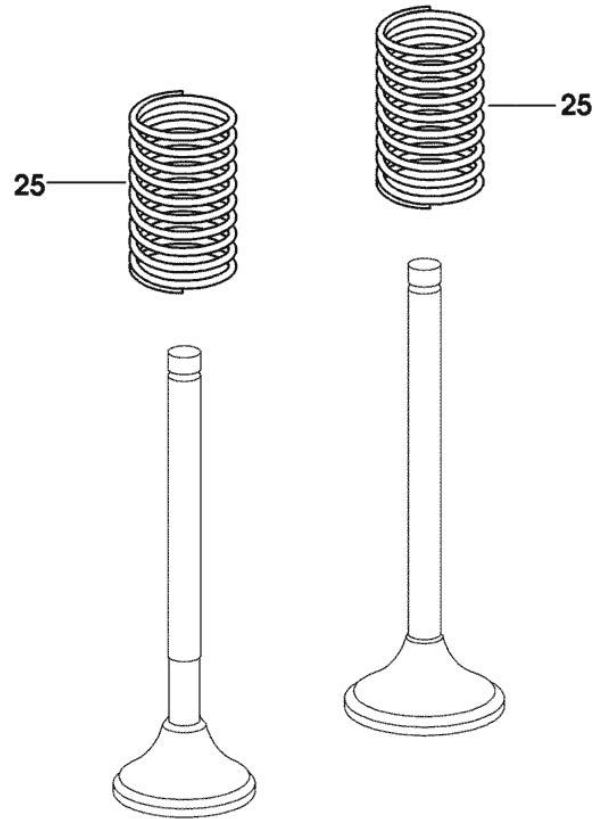

9_34814_01_0_0

OIL PAN

| Fig. | P/n | QTY | Name |
|------|-----|-----|------|
|------|-----|-----|------|

Notes:
[ROCK 60 M]

| | | | |
|----|-----------------|----|------------------------|
| 18 | 0.007.0614.0/10 | 1 | gasket |
| 19 | 0.007.1422.0/40 | 1 | oil sump |
| 20 | 2.1560.054.0 | 1 | gasket 21 x 26 |
| 21 | 2.3199.001.2 | 1 | plug 1/2" gas |
| 22 | 2.1470.004.2 | 22 | lock washer 8 |
| 24 | 2.0112.226.2 | 7 | screw m 8 p.1.25 x 85 |
| 25 | 2.0112.215.2 | 13 | screw m 8 p.1.25 x 40 |
| 26 | 2.0112.411.2 | 4 | screw m 12 p.1.75 x 30 |
| 27 | 2.1470.007.2 | 4 | lock washer 12 |
| 28 | 2.0112.239.2 | 2 | screw m 8 p.1.25 x 150 |
| 29 | 2.0112.722.2 | 4 | screw m 18 p.2.5 x 65 |
| 30 | 2.1475.007.7 | 4 | washer 18 |
| 31 | 0.008.8586.0/10 | 4 | shim mm 0.20 |
| 32 | 0.008.8587.0/10 | 8 | shim mm 0.50 |

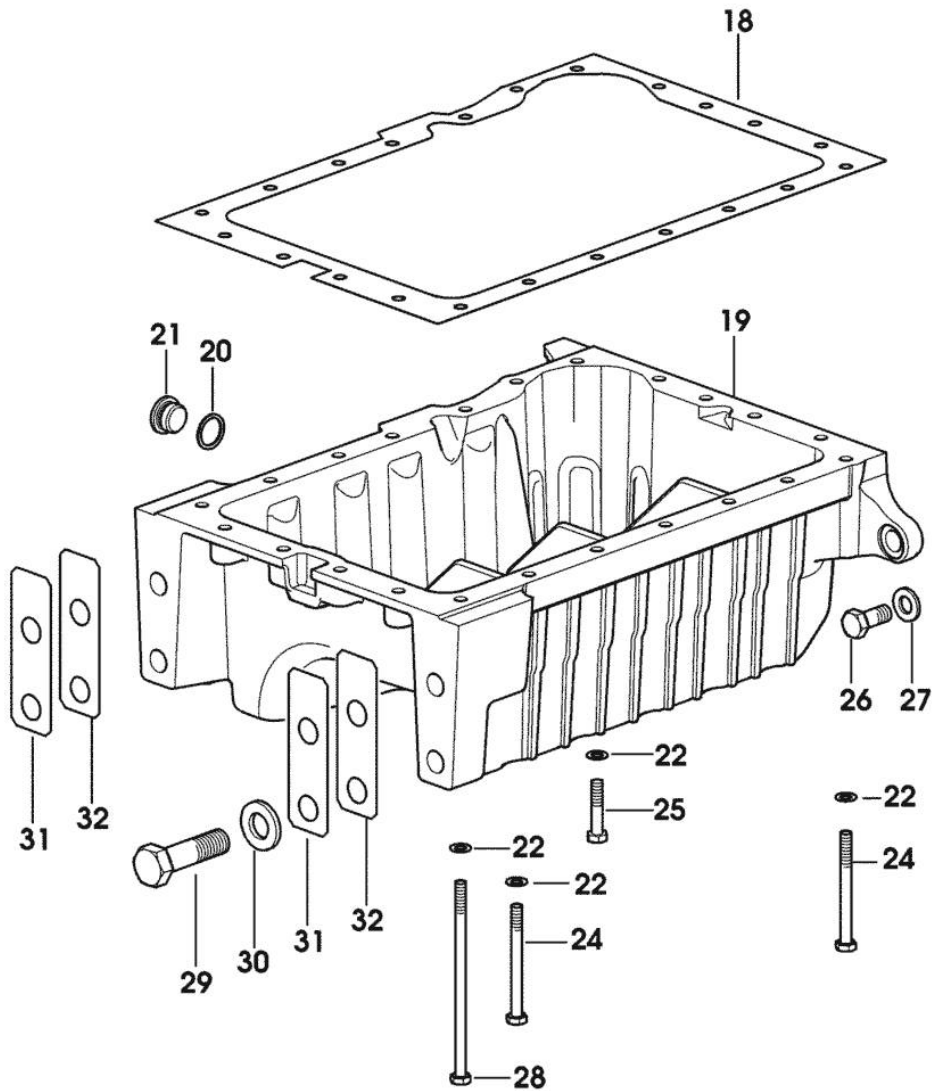

9_35115_01_0_0

Section: ENGINE
LUBRICATION

| Fig. | P/n | QTY | Name |
|------|-----|-----|------|
|------|-----|-----|------|

Notes:
 [ROCK 60 M]

| | | | |
|-----|-----------------|---|-------------------------------|
| 2 | 0.041.1135.4 | 1 | plug 1" gas |
| 2.2 | 2.1569.072.0 | 1 | gasket 32 x 39.5 x 2 |
| 3 | 2.0312.205.2 | 2 | screw |
| 4 | 2.1480.014.1 | 2 | washer 8 |
| 5 | 0.065.1565.0/10 | 1 | pipe union |
| 6 | 0.065.1567.0/10 | 1 | filter |
| 7 | 2.1539.042.0 | 1 | special oil seal 47.35x1.78 |
| 8 | 2.3339.307.0 | 1 | pipe fitting m 22 p.1.5-3/4" |
| 11 | 2.1011.105.2 | 1 | nut m 8 p.1.25 |
| 12 | 2.1470.004.2 | 1 | lock washer 8 |
| 13 | 0.065.1538.0 | 1 | flange |
| 14 | 2.1539.040.0 | 1 | special oil seal 21.82 x 3.53 |
| 15 | 2.1539.065.0 | 2 | special oil seal 8.73 x 1.78 |
| 16 | 0.085.1513.2/20 | 1 | dipstick |

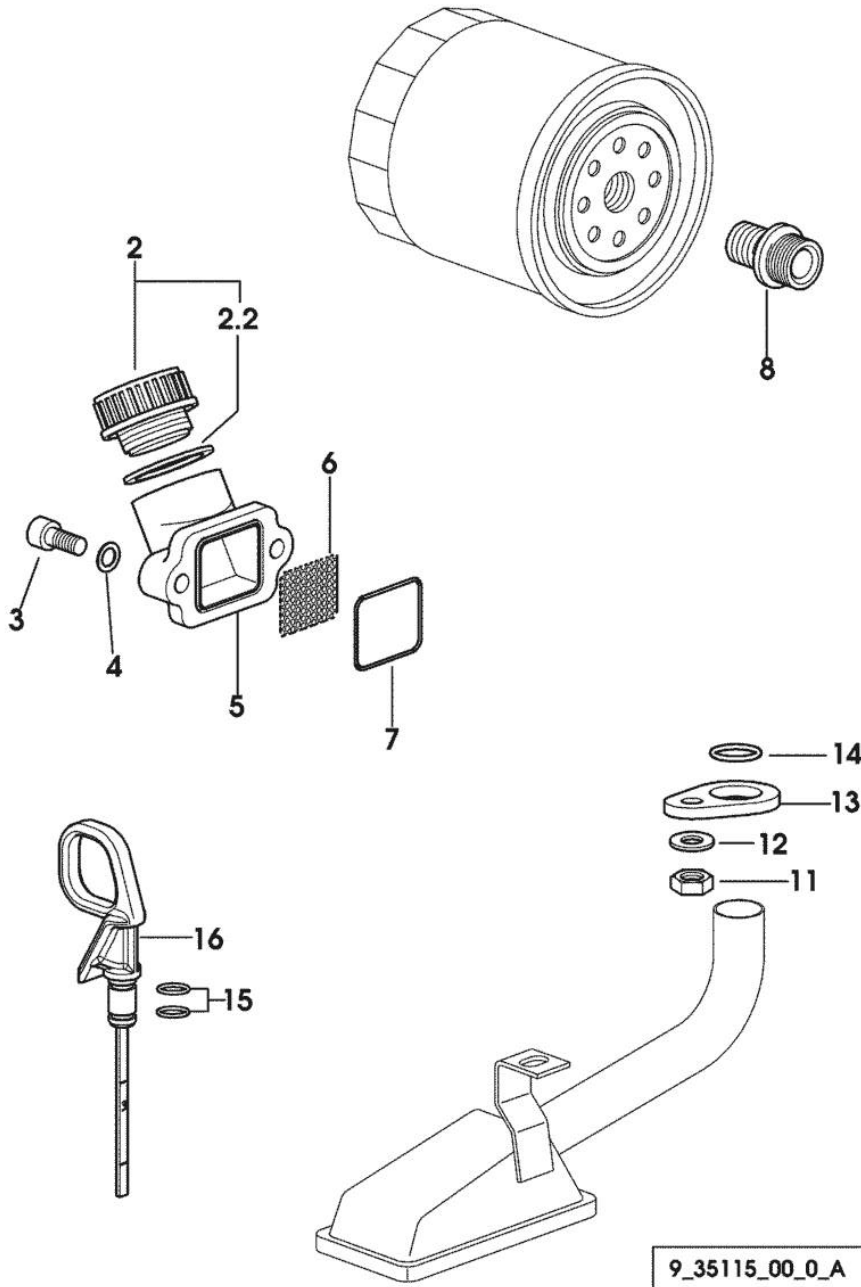

9_35115_00_0_A

LUBRICANT OIL SUCTION PIPE

| Fig. | P/n | QTY | Name |
|------|-----|-----|------|
|------|-----|-----|------|

Notes:

[ROCK 60 M]

| | | | |
|----|--------------|---|-----------------------|
| 83 | 2.1470.004.2 | 1 | lock washer 8 |
| 84 | 2.0112.205.2 | 1 | screw m 8 p.1.25 x 16 |
| 85 | 0.007.1425.3 | 1 | tube |

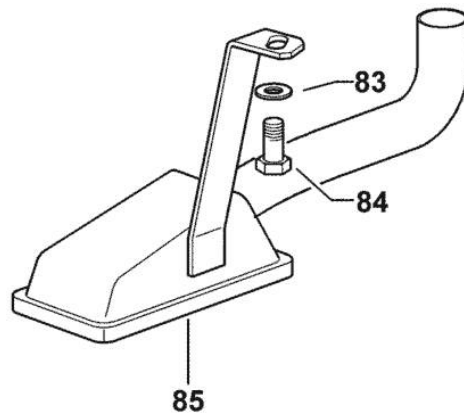

9_34815_06_0_0

Section: ENGINE

OIL PUMP

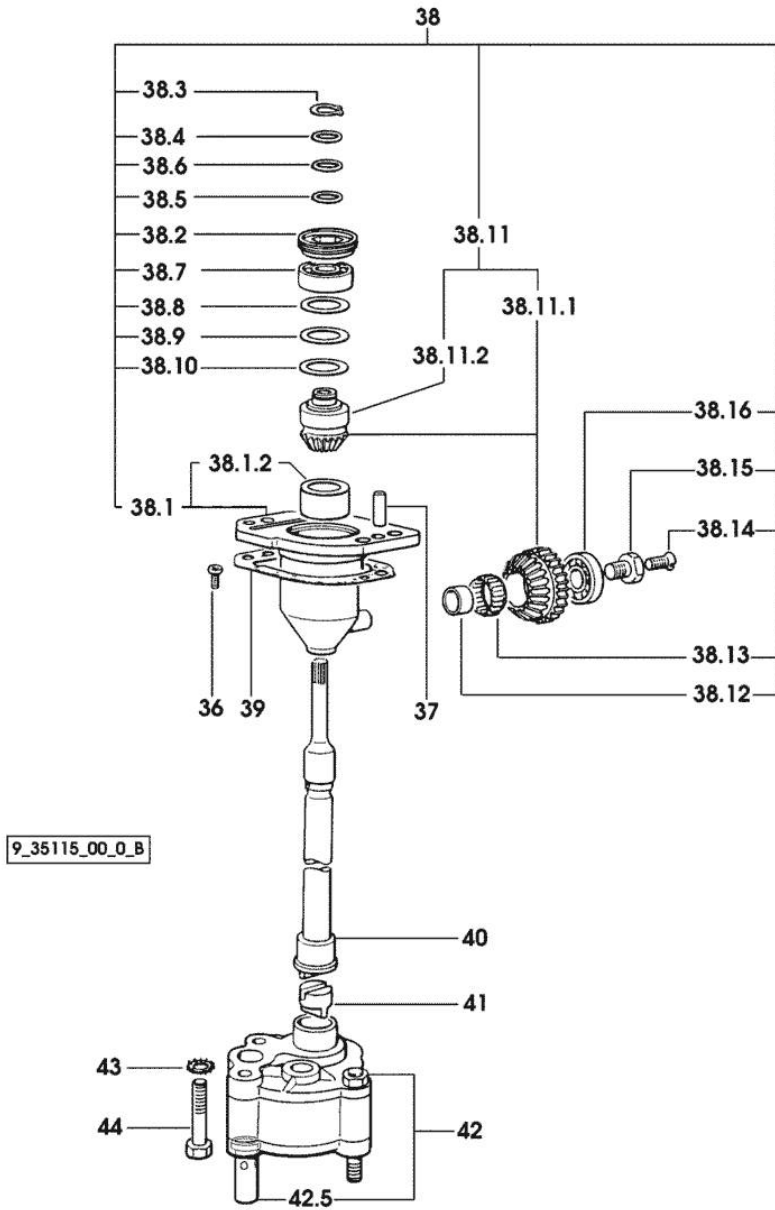

| Fig. | P/n | QTY | Name |
|------|-----|-----|------|
|------|-----|-----|------|

Notes:
[ROCK 60 M]

| | | | |
|---------|-----------------|---|----------------------------------|
| 36 | 2.0169.005.2 | 2 | screw m 6 p.1 x 12 |
| 37 | 2.1651.711.0 | 2 | pin 8 x 14 |
| 38 | 0.075.1551.4/20 | 1 | support |
| 38.1 | 0.075.1551.3/30 | 1 | support |
| 38.1.2 | 2.1559.186.0 | 1 | special bushing 26 x 31.5 x 35 |
| 38.2 | 2.1219.025.2/10 | 1 | ring nut m 36 p.1.5 |
| 38.3 | 2.1410.057.1 | 1 | circlip 15 |
| 38.4 | 2.1589.153.0 | 1 | shoulder ring 15.2 x 19 x 1.00 |
| 38.5 | 2.1589.146.0 | 2 | shoulder ring 15.2 x 19 x 0.15 |
| 38.6 | 2.1589.147.0 | 2 | shoulder ring 15.2 x 19 x 0.10 |
| 38.7 | 2.2020.001.0 | 1 | ball bearing 15 x 32 x 8.00 |
| 38.8 | 2.1589.148.0 | 1 | shoulder ring 28.2 x 31.8 x 0.5 |
| 38.9 | 2.1589.150.0 | 2 | shoulder ring 28.2 x 31.8 x 0.1 |
| 38.10 | 2.1589.151.0 | 2 | shoulder ring 28.2 x 31.8 x 0.15 |
| 38.11 | 0.000.0000.1 | | cannot be supplied |
| 38.11.1 | 0.065.1558.6/10 | 1 | bevel drive |
| 38.11.2 | 0.065.1559.0 | 1 | bush |
| 38.12 | 2.2680.020.0 | 1 | ring 12 x 15 x 12 |
| 38.13 | 2.2725.016.0 | 1 | roller cage 15 x 21 x 12 |
| 38.14 | 2.0342.007.6 | 1 | screw m 4 p.0.7 x 30 |
| 38.15 | 2.0399.128.2/10 | 1 | screw m 8 p.1 x 8 |
| 38.16 | 2.2030.002.0 | 1 | ball bearing 12 x 28 x 8 |
| 39 | 0.065.1560.0/20 | 2 | gasket |
| 40 | 0.065.1569.0/40 | 1 | shaft |
| 41 | 0.065.1562.0/10 | 1 | joint |
| 42 | 0.010.5481.4 | 1 | oil pump |
| 42.5 | 0.065.1552.3/60 | 1 | valve |
| 43 | 2.1470.006.2 | 2 | lock washer 10 |
| 44 | 2.0112.323.2 | 2 | screw m 10 p.1.5x70 |

Section: ENGINE
LUBRICATION

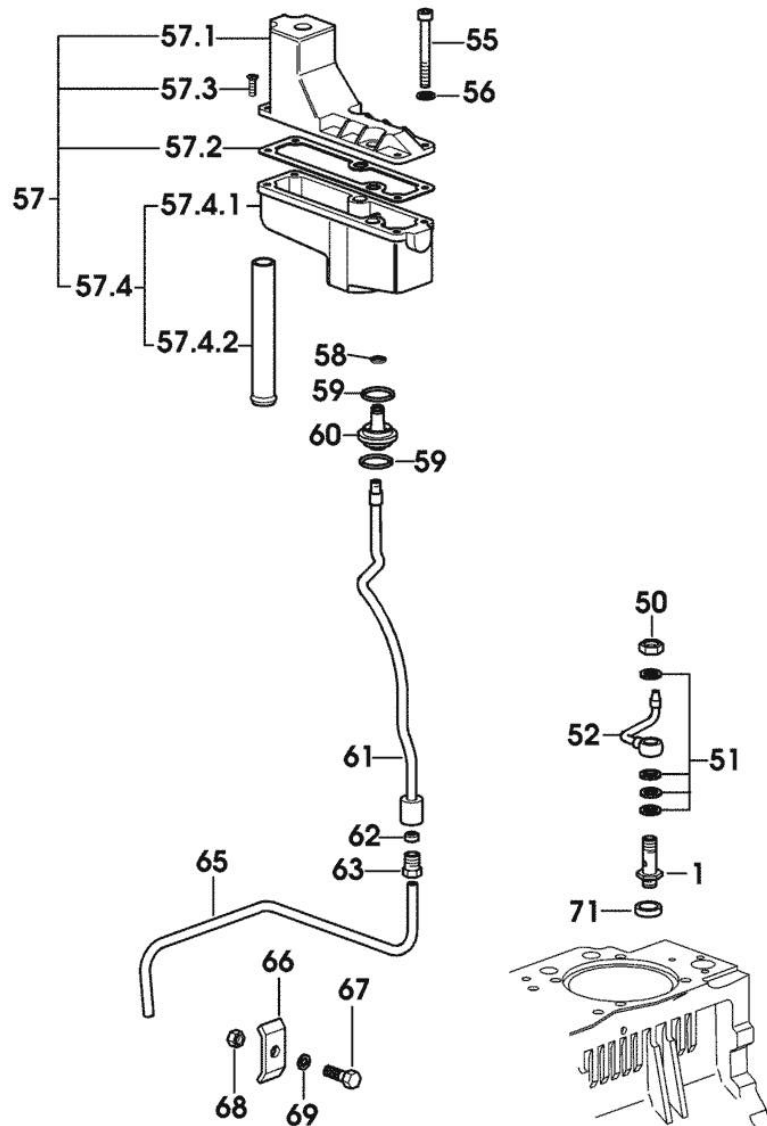

| Fig. | P/n | QTY | Name |
|------|-----|-----|------|
|------|-----|-----|------|

Notes:
[ROCK 60 M]

| | | | |
|--------|-----------------|----|-------------------------------|
| 1 | 0.065.1160.3/20 | 3 | valve |
| 50 | 2.1099.108.2 | 3 | special nut m 10 p.1 |
| 51 | 2.1560.006.0 | 12 | gasket 10.2 x 16 |
| 52 | 0.086.1550.2 | 3 | sprayer nozzle |
| 55 | 2.0312.221.2 | 2 | screw m 8 p.1.25x75 |
| 56 | 2.1480.014.1 | 2 | washer 8 |
| 57 | 0.066.1552.4/10 | 1 | sediment bowl |
| 57.1 | 0.066.1553.0 | 1 | cover |
| 57.2 | 0.066.1554.0/10 | 1 | gasket |
| 57.3 | 2.0351.203.6 | 4 | screw 3.5x9.5 |
| 57.4 | 0.000.0000.1 | | cannot be supplied |
| 57.4.1 | 0.066.1552.0 | 1 | sediment bowl |
| 57.4.2 | 0.066.1555.0 | 1 | tube |
| 58 | 2.1532.012.0 | 1 | oil seal 6.75 x 1.78 |
| 59 | 2.1539.072.0 | 2 | special oil seal 23.52 x 1.78 |
| 60 | 0.066.1558.0 | 1 | bush |
| 61 | 0.066.1557.2 | 1 | tube |
| 62 | 2.3350.003.1 | 1 | nosepiece 8 |
| 63 | 2.3339.418.1 | 1 | pipe fitting m 12 p.1 |
| 65 | 0.007.1427.0 | 1 | tube |
| 66 | 0.002.8816.0 | 1 | small plate |
| 67 | 2.0112.007.2 | 1 | screw m 6 p.1 x 20 |
| 68 | 2.1011.103.2 | 1 | nut m 6 p.1 |
| 69 | 2.1470.002.2 | 1 | lock washer 6 |
| 71 | 2.1579.154.2 | 3 | spacer 10.5x16x3 |

9_35115_00_0_C

Thank you so much for reading.
Please click the “Buy Now!”
button below to download the
complete manual.



After you pay.

You can download the most
perfect and complete manual in
the world immediately.

Our support email:

ebooklibonline@outlook.com