

Section: ENGINE  
CRANKCASE

9\_33211\_00\_0\_A

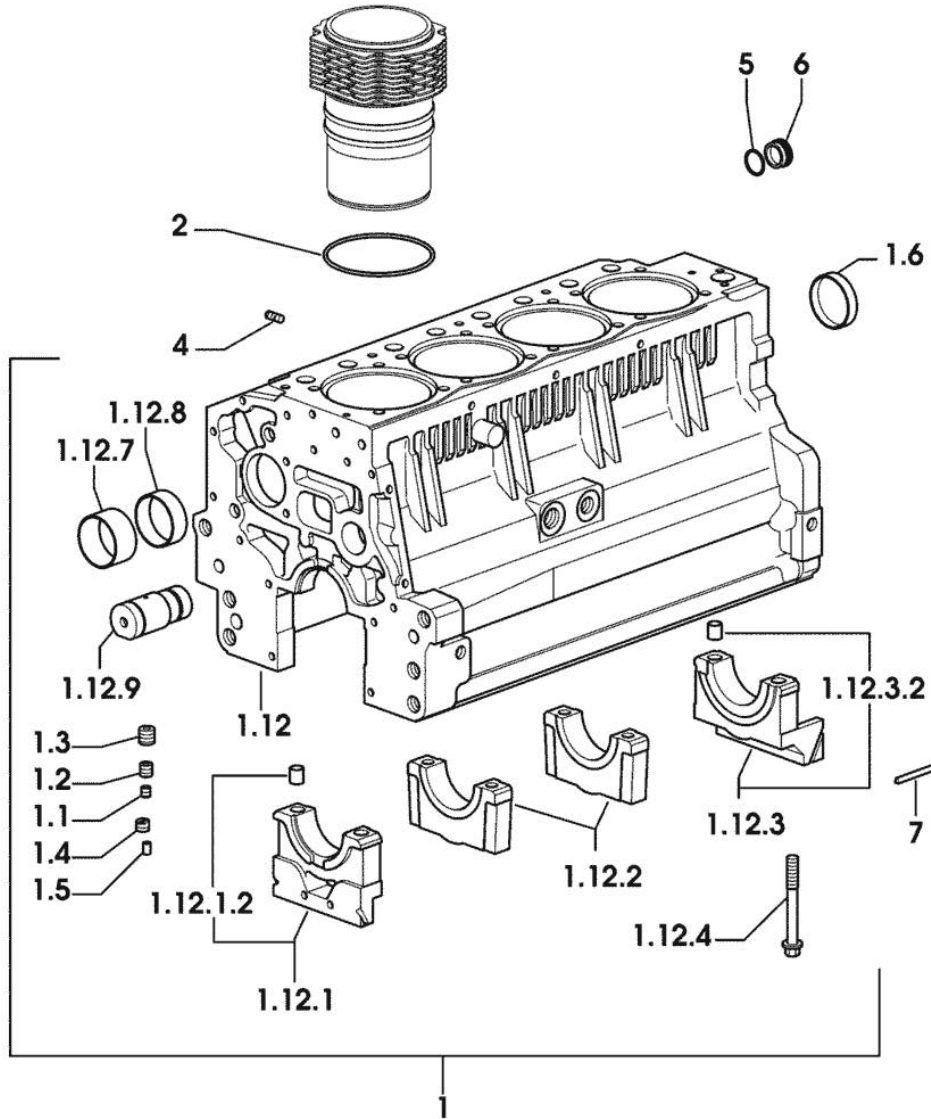

Fig.	P/n	QTY	Name
------	-----	-----	------

Notes:  
[ROCK 70 M]

1	0.007.1140.6/10	1	crankcase
1.1	2.3130.001.1	11	plug 1/8" gas
1.2	2.3130.002.1	2	plug 1/4" gas
1.3	2.3130.003.1	7	plug 3/8" gas
1.4	2.1324.011.0	1	plug
1.5	2.3199.092.0	4	plug 8 x 12
1.6	2.3179.012.0	1	plug 60
1.12	0.000.0000.1		cannot be supplied
1.12.1	0.065.1112.7	1	support
1.12.1.2	2.1699.165.0	1	bush 12.3x15x16
1.12.2	0.065.1114.0/10	3	support
1.12.3	0.065.1116.3	1	support
1.12.3.2	2.1699.165.0	1	bush 12.3x15x16
1.12.4	0.065.1117.0	10	screw m 12 x 100
1.12.7	0.065.1141.0	1	special bushing 59X55X30
1.12.8	0.065.1140.0	4	special bushing 59X55X20
1.12.9	0.066.1151.0	1	pin
2	2.1539.130.0/10	4	special oil seal 117.07x3.53
4	2.0432.003.7	12	stud bolt m 8 p.1.25 / p.1 x 20
5	2.1532.072.0	1	oil seal 26.70x1.78
6	2.3199.405.2	1	plug m 28 p.1.5
7	0.066.1152.0/10	4	gasket

Section: ENGINE  
**GUARD PLATE**

Fig.	P/n	QTY	Name
------	-----	-----	------

Notes:  
 [ROCK 70 M]

1	0.007.1262.3/50	1	guard
2	0.007.1271.0/10	1	small column m 8 p.1.25 / L = mm 60
3	0.007.1272.0/10	2	small column m 8 p.1.25 / L = mm 50
5	2.1310.004.2	3	flat washer 8.4x17
7	2.0112.203.2	3	screw m 8 p.1.25 x 12

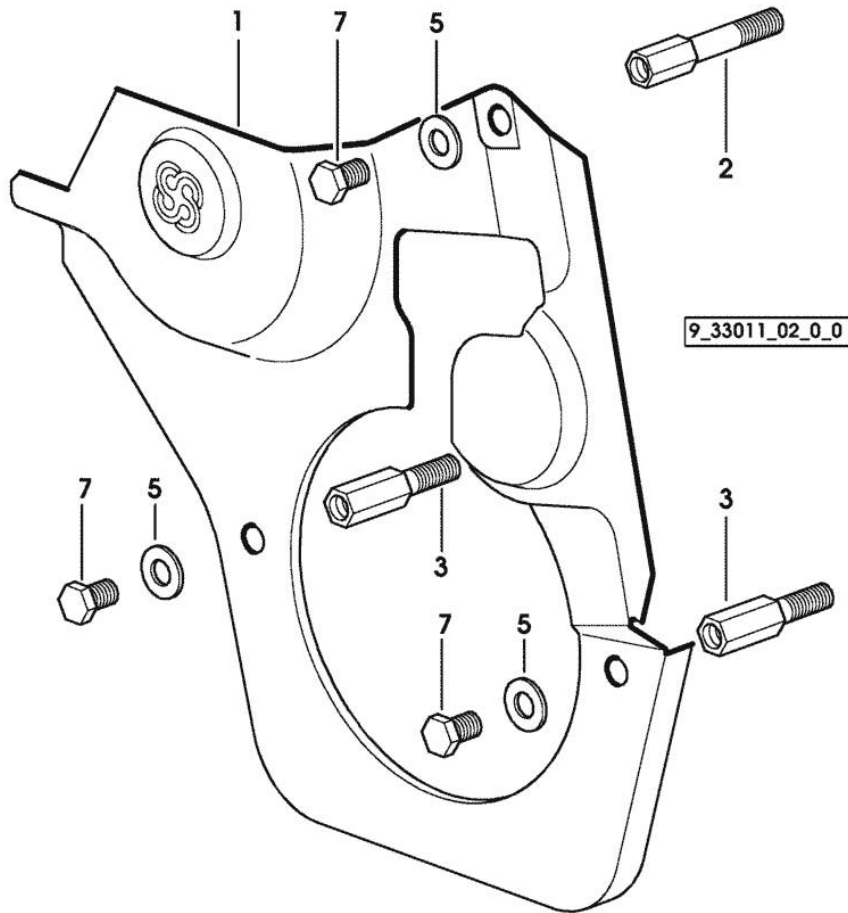

9\_33211\_00\_0\_B

Section: ENGINE  
TIMING CASE

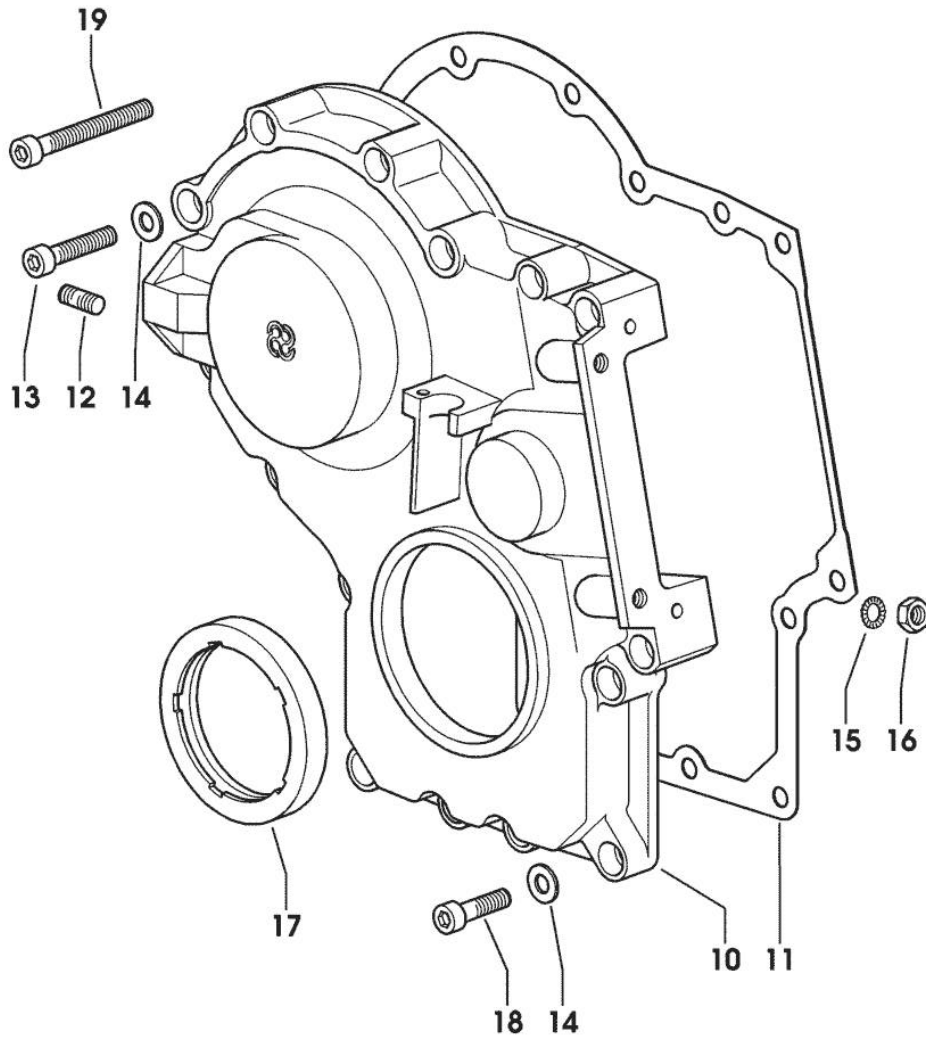

Fig.	P/n	QTY	Name
<b>Notes:</b> [ROCK 70 M]			
10	0.013.4981.0	1	guard -> 1156 X ROCK 70
10	0.065.1132.0/50	1	guard 1155 <- X ROCK 70
11	0.065.1150.0/30	1	gasket
12	2.0432.003.7	2	stud bolt m 8 p.1.25 / p.1 x 20
13	2.0312.214.2	3	screw m 8 p.1.25 x 40
14	2.1480.014.1	15	washer 8
15	2.1470.004.2	4	lock washer 8
16	2.1011.405.2	2	nut m 8 p.1
17	2.1529.141.0	1	special oil seal
18	2.0312.208.2	8	screw m 8 p.1.25 x 25
19	2.0312.219.2	4	screw m 8 p.1.25x65

Section: ENGINE  
**CRANKCASE**

Fig.	P/n	QTY	Name
------	-----	-----	------

Notes:  
 [ROCK 70 M]

6	2.0439.250.7	1	stud bolt m 12 / m 10 x 30
7	0.011.9294.0/10	1	bush
30	2.0112.511.2	8	screw m 14 p.2 x 30
31	2.1651.912.0	2	cylindrical plug 12x28
32	2.1651.917.0	1	cylindrical plug 12x40
33	2.0432.257.7	1	stud bolt m 12 p.1.75 - 1.25 x 30
34	0.007.9745.0/10	1	flange

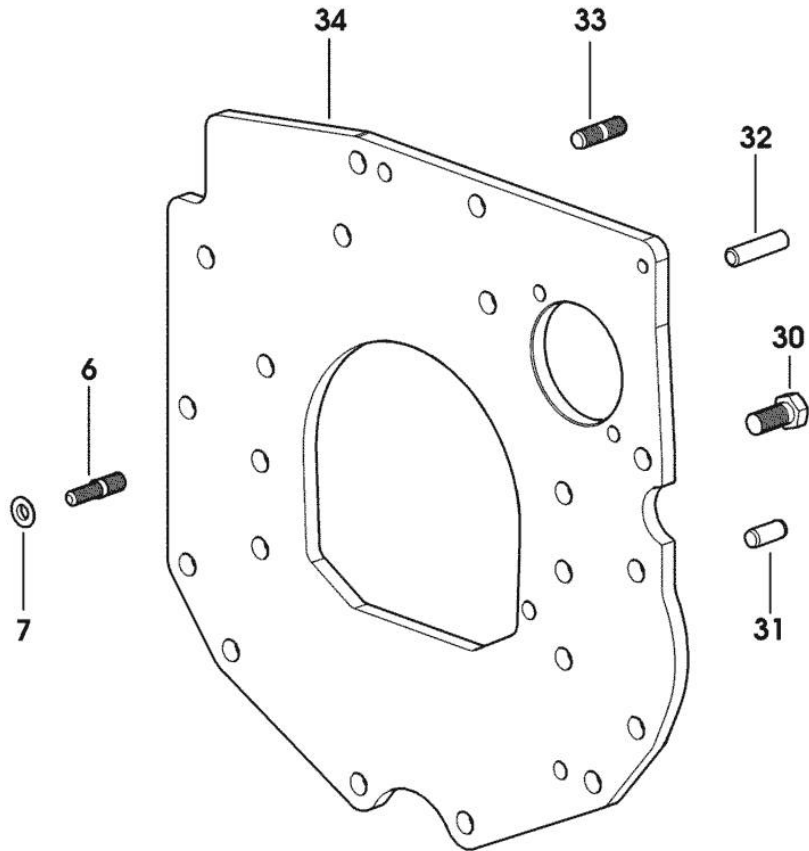

9\_33311\_02\_0\_0

**SIDE PLUG FOR CYLINDER BLOCK**

Fig.	P/n	QTY	Name
------	-----	-----	------

Notes:  
[ROCK 70 M]

22	2.1560.017.0	1	gasket 22.2 x 27
23	2.3120.002.4	1	plug m 22 x 1.5

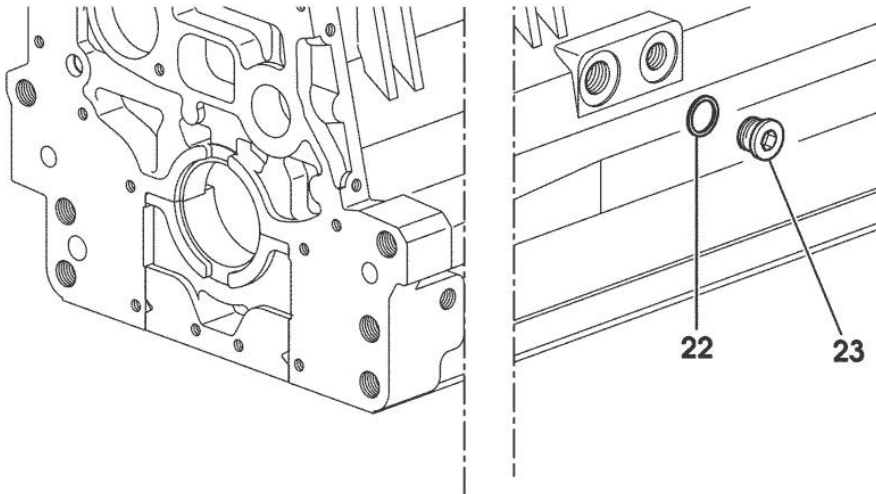

9\_33211\_07\_0\_0

Section: ENGINE

**CRANKSHAFT**

9\_33212\_00\_0\_0

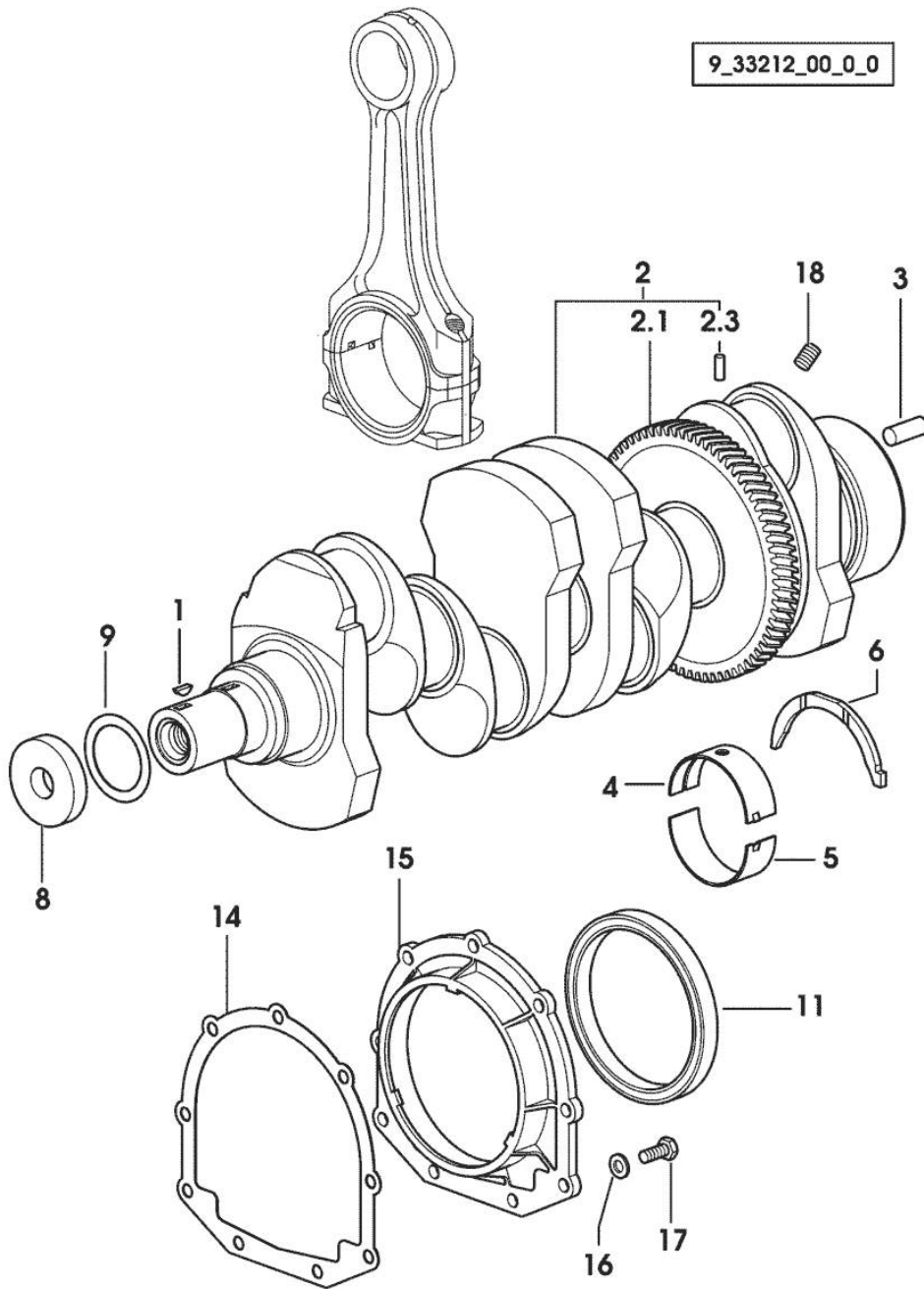

Fig.	P/n	QTY	Name
------	-----	-----	------

Notes:  
[ROCK 70 M]

1	2.1720.006.0	1	key 4x6.5
2	0.086.1210.3/30	1	crankshaft
2.1	0.065.1211.0/10	1	crown wheel
2.3	2.1630.608.0	1	pin 6x16
3	2.1651.915.0	1	pin 12x35
4	0.065.1215.0	5	main half bushing STANDARD
4	0.065.1215.7		main half bushing - mm 0.25
4	0.065.1215.8		main half bushing - mm 0.50
5	0.065.1216.0	5	main half bushing
5	0.065.1216.7		main half bushing - mm 0.25
5	0.065.1216.8		main half bushing - mm 0.50
6	0.065.1218.0	4	shim STANDARD
6	0.065.1218.7		shim + mm 0.10
6	0.065.1218.8		shim + mm 0.15
8	2.1599.524.7	1	washer 21x60x12
9	2.1589.189.0	2	shoulder ring mm 1.00
11	2.1529.073.0	1	special oil seal 110x130x13
14	0.065.1254.0/20	1	gasket
15	0.007.1711.0/10	1	cover
16	2.1475.002.2	9	conical washer 8
17	2.0112.207.2	9	screw m 8 p 1.25 x 20
18	2.3130.001.1	4	plug 1/8" gas

Section: ENGINE

**CYLINDER - PISTON - CONNECTING ROD**

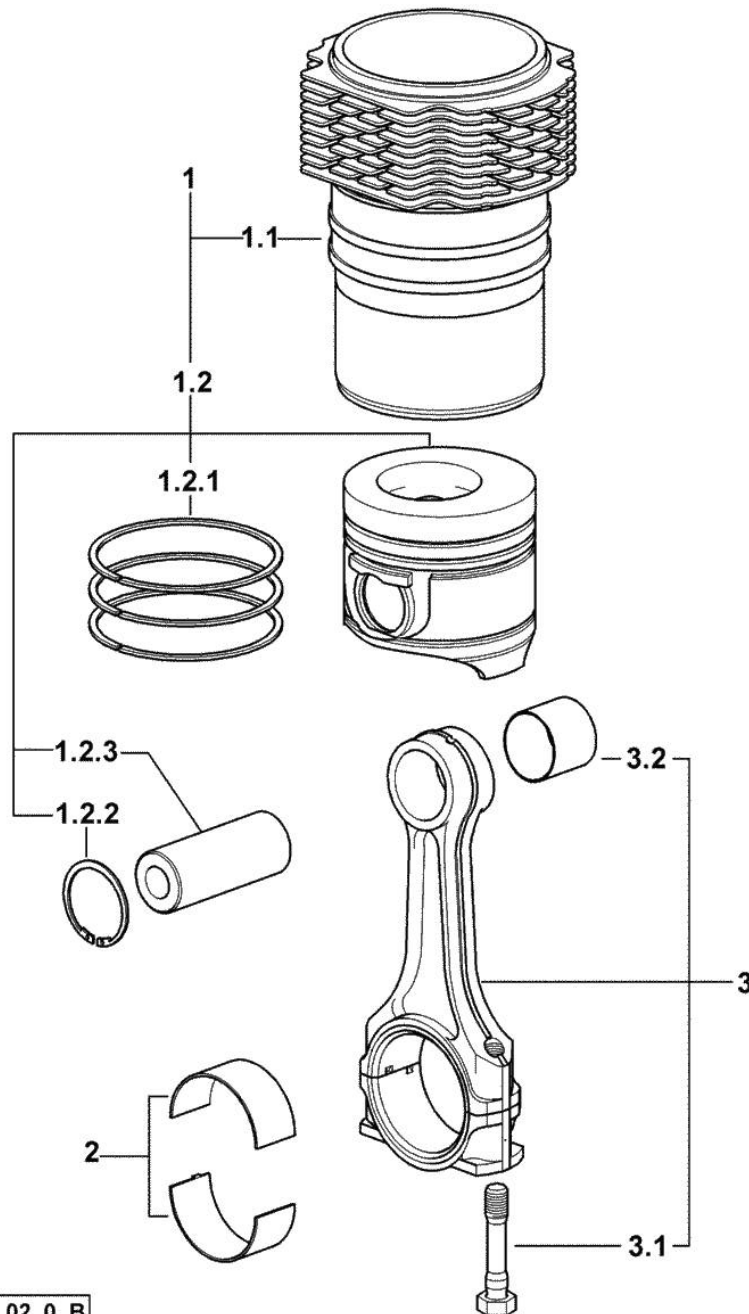

Fig.	P/n	QTY	Name
------	-----	-----	------

**Notes:**

71504 <= X ROCK 70 [ROCK 70 M]

1	0.336.0065.A	4	cyl. piston assembly "A" - CLASS A
1	0.336.0065.B	4	cyl. piston assembly "B" - CLASS B
1.1	0.A13.0355.0	1	engine cylinder "A" - CLASS A
1.1	0.B13.0355.0	1	engine cylinder "B" - CLASS B
1.2	0.086.0060.A	1	complete piston "A" - CLASS A
1.2	0.086.0060.B	1	complete piston "B" - CLASS B
1.2.1	0.086.0052.6/10	1	piston ring set
1.2.2	2.1411.014.1	2	circlip 35
1.2.3	0.078.1236.0	1	piston pin Ø 18 / Ø 35 / L = mm 86
2	0.065.1225.0	8	con.rod half bushing STANDARD - A = 28.75 -> 29.00
2	0.065.1225.7	8	con.rod half bushing - mm 0.25
2	0.065.1225.8	8	con.rod half bushing - mm 0.50
3	0.078.1220.3/30	4	engine connecting rod
3.1	2.0399.213.0	2	screw m 12 p.1.25x61.5
3.2	2.1559.114.0/10	1	special bushing

Section: ENGINE

**CYLINDER - PISTON - CONNECTING ROD**

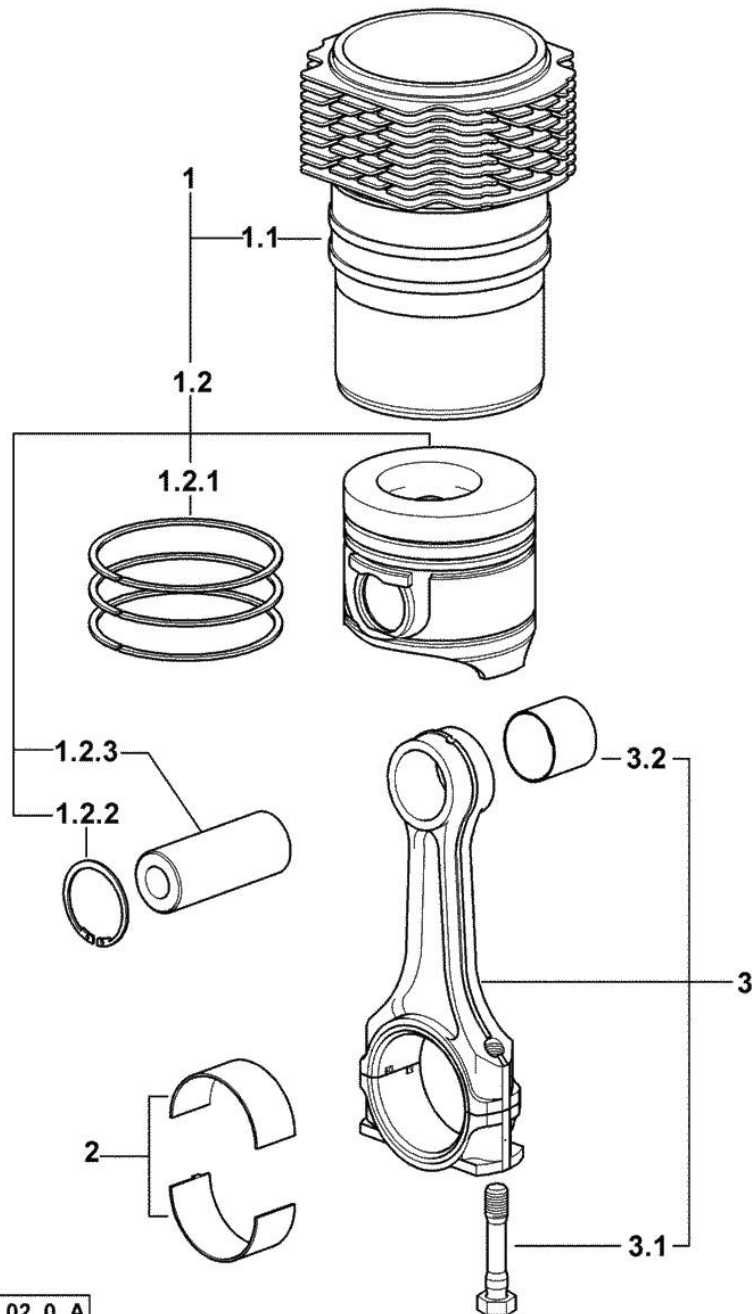

Fig.	P/n	QTY	Name
------	-----	-----	------

**Notes:**

=> 71505 X ROCK 70 [ROCK 70 M]

1	0.379.0065.A	4	cyl. piston assembly "A" - CLASS A
1	0.379.0065.B	4	cyl. piston assembly "B" - CLASS B
1.1	0.A13.0355.0	1	engine cylinder "A" - CLASS A
1.1	0.B13.0355.0	1	engine cylinder "B" - CLASS B
1.2	0.379.0060.A	1	complete piston "A" - CLASS A
1.2	0.379.0060.B	1	complete piston "B" - CLASS B
1.2.1	0.086.0052.6/10	1	piston ring set
1.2.2	2.1411.014.1	2	circlip 35
1.2.3	0.078.1236.0	1	piston pin Ø 18 / Ø 35 / L = mm 86
2	0.065.1225.0	8	con.rod half bushing STANDARD - A = 28.75 -> 29.00
2	0.065.1225.7	8	con.rod half bushing - mm 0.25
2	0.065.1225.8	8	con.rod half bushing - mm 0.50
3	0.078.1220.3/30	4	engine connecting rod
3.1	2.0399.213.0	2	screw m 12 p.1.25x61.5
3.2	2.1559.114.0/10	1	special bushing



Section: ENGINE

**ENGINE FLYWHEEL**

Fig.	P/n	QTY	Name
------	-----	-----	------

Notes:  
[ROCK 70 M]

1	0.007.9562.3/10	1	flywheel
1.2	0.065.1242.0	1	crown wheel Z = 123
2	2.0119.174.0/10	6	screw m 12 p.1.25x45
3	2.2041.008.0	1	ball bearing 20x47x14

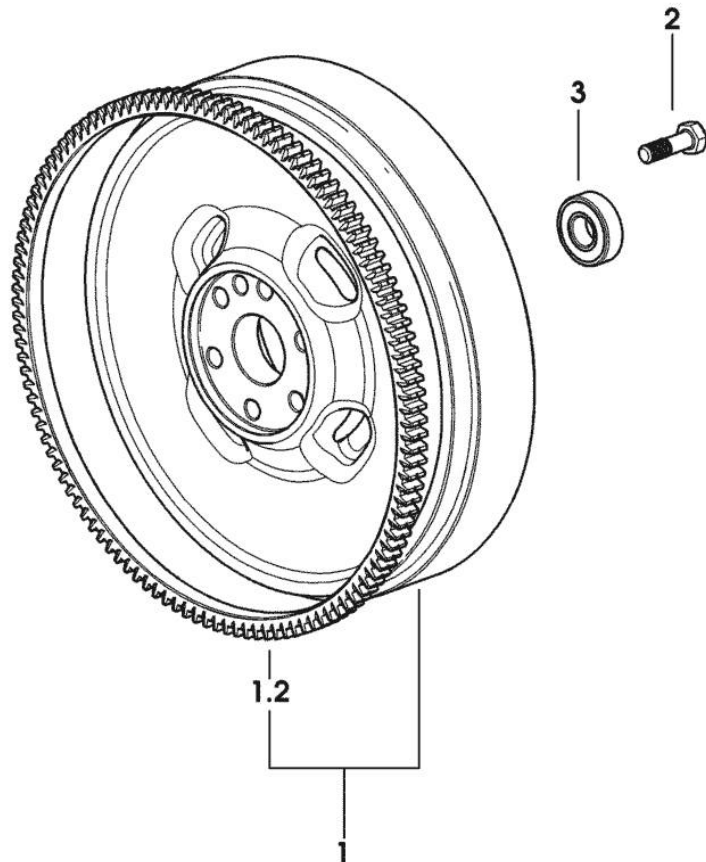

9\_33312\_03\_0\_0

Section: ENGINE

**CRANKSHAFT PULLEY**

Fig.	P/n	QTY	Name
------	-----	-----	------

Notes:  
[ROCK 70 M]

1	0.007.1330.0/40	1	pulley
2	2.1589.189.0	2	shoulder ring mm 1.00
3	0.085.1248.0/20	1	hub
4	2.0399.144.7/10	1	screw m 20 p.1.5x51
6	2.1720.006.0	1	key 4x6.5

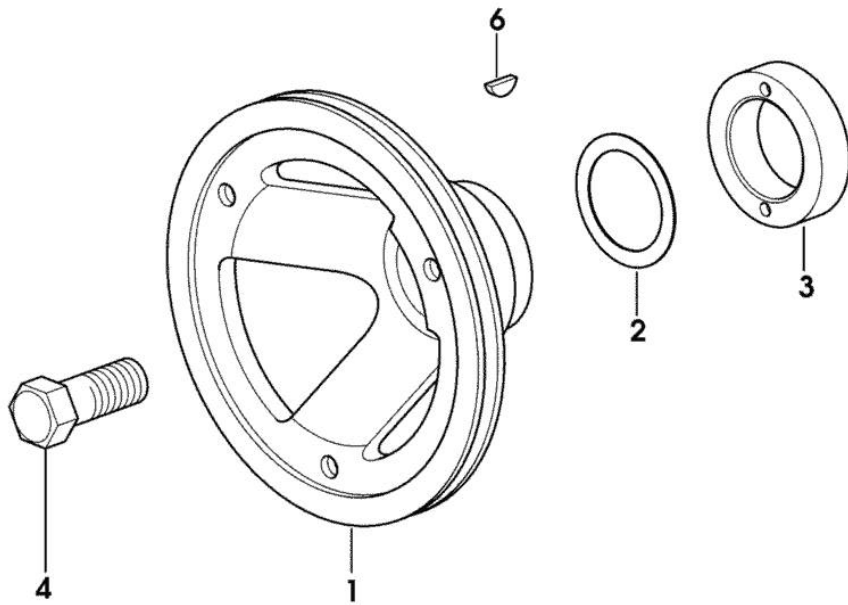

9\_33012\_02\_0\_0

Section: ENGINE  
**COUNTERWEIGHTS**

Fig.	P/n	QTY	Name
------	-----	-----	------

Notes:  
 [ROCK 70 M]

25	2.1589.139.0	1	shoulder ring mm 0.3
26	2.1589.140.0	3	shoulder ring mm 0.1
29	2.1579.628.0	3	spacer 16.5x26x0.1
33	2.1579.629.0	6	spacer 12.5x26x0.1
34	2.1589.048.0	1	shoulder ring 16.5x26x0.3
35	2.1589.049.0	1	shoulder ring 12.5x26x0.3
40	0.086.1233.3/30	1	mass sx/lh/li
40.2	2.1559.115.0	2	special bushing 26x30x30
40.3	0.000.0000.1		cannot be supplied
40.4	2.1651.302.0	1	roll pin 4x6
41	0.065.1233.3/30	1	mass dx/rh/re
41.2	2.1559.115.0	2	special bushing 26x30x30
41.3	0.000.0000.1		cannot be supplied
41.99	0.000.0000.1		cannot be supplied
41.99.4	2.1651.302.0	1	roll pin 4x6
41.99.5	2.1410.018.1	1	circlip 45
42	0.000.0000.1		cannot be supplied
42.1	0.086.1231.0/10	1	box
42.2	2.3130.001.1	4	plug 1/8" gas
43	2.1631.717.0	2	roll pin 8 x 40
44	2.1579.626.0	2	spacer 13.2x16x11
45	2.0139.028.2	4	screw m 12
46	2.1699.191.0	1	bush 7x10x16
47	0.000.0000.1		cannot be supplied
47.1	0.065.1234.0/10	1	shaft
47.2	2.3130.001.1	1	plug 1/8" gas
48	2.1589.185.0	4	shoulder ring 26.1x34x1

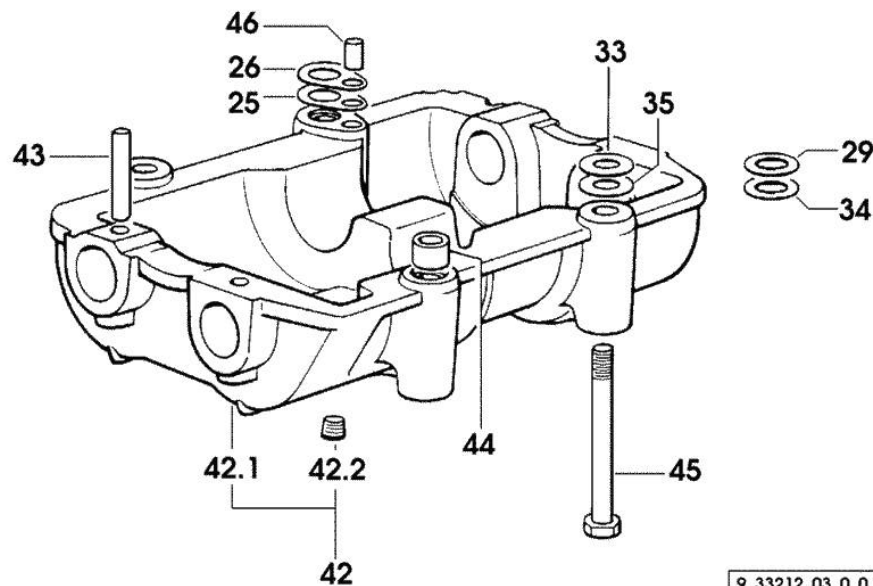
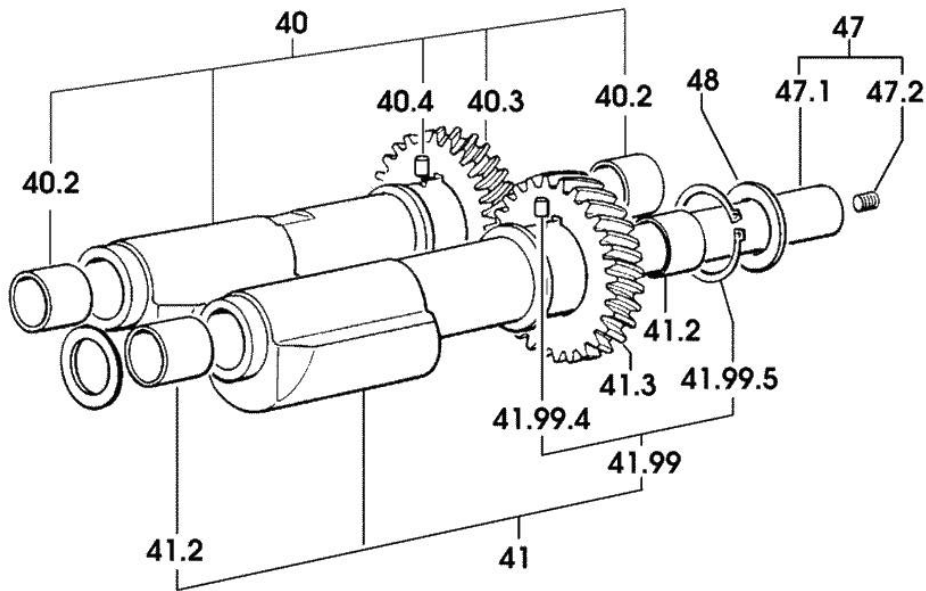

9\_33212\_03\_0\_0

Section: ENGINE

**CAMSHAFT**

Fig.	P/n	QTY	Name
------	-----	-----	------

Notes:

71504 <= X ROCK 70 [ROCK 70 M]

1	0.065.1331.2	8	rod
2	2.1569.114.0/10	16	gasket 14x18.5x8
3	0.065.1332.0	8	sleeve
4	2.4019.300.1/10	8	spring 18.5x52x2
5	2.1599.437.0	8	shoulder ring
6	0.065.1330.0	8	tappets
7	0.013.5017.0	1	gear z=58
8	2.0132.207.2	4	screw m 10 p.1 x 25
9	0.066.1310.3/40	1	camshaft
9.2	0.065.1324.0/10	1	gear Z = 32
10	0.065.1350.0	1	small disc
11	2.1410.016.1	1	circlip 40
12	0.065.1352.0	1	shim
13	0.065.1351.0	2	shoulder ring
14	0.065.1323.0/30	1	gear Z = 29
16	2.0312.205.2	2	screw
17	2.1480.014.1	2	washer 8
18	0.065.1353.0	1	small plate
19	0.007.1177.3/20		gear z = 57
			- WITH RED IDENTIFICATION STAMP
19.2	2.1559.185.0/10	1	bushing
20	0.007.1178.3/20		gear z = 57
			- WITH YELLOW IDENTIFICATION STAMP
20.2	2.1559.185.0/10	1	bushing
21	0.007.1179.3/20		gear z = 57
			- WITH GREEN IDENTIFICATION STAMP
21.2	2.1559.185.0/10	1	bushing
22	2.1559.398.0	1	bushing 10.5x13x12

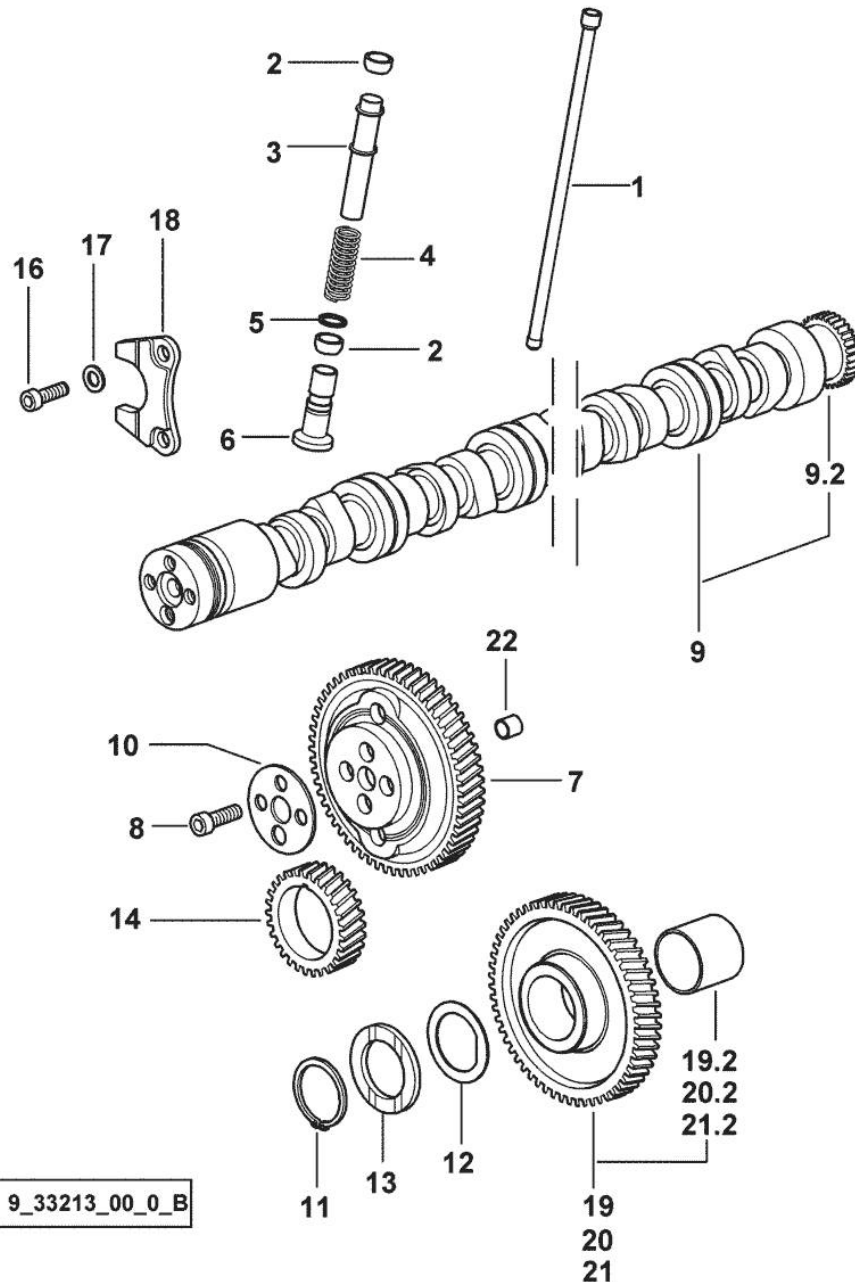

Section: ENGINE

**CAMSHAFT**

Fig.	P/n	QTY	Name
------	-----	-----	------

**Notes:**

=> 71505 X ROCK 70 [ROCK 70 M]

1	0.065.1331.2	8	rod
2	2.1569.114.0/10	16	gasket 14x18.5x8
3	0.065.1332.0	8	sleeve
4	2.4019.300.1/10	8	spring 18.5x52x2
5	2.1599.437.0	8	shoulder ring
6	0.065.1330.0	8	tappets
7	0.013.5017.0	1	gear z=58
8	2.0132.207.2	4	screw m 10 p.1 x 25
9	0.007.1712.3/10	1	camshaft
9.2	0.065.1324.0/10	1	gear Z = 32
10	0.065.1350.0	1	small disc
11	2.1410.016.1	1	circlip 40
12	0.065.1352.0	1	shim
13	0.065.1351.0	2	shoulder ring
14	0.065.1323.0/30	1	gear Z = 29
16	2.0312.205.2	2	screw
17	2.1480.014.1	2	washer 8
18	0.065.1353.0	1	small plate
19	0.007.1177.3/20		gear z = 57
			- WITH RED IDENTIFICATION STAMP
19.2	2.1559.185.0/10	1	bushing
20	0.007.1178.3/20		gear z = 57
			- WITH YELLOW IDENTIFICATION STAMP
20.2	2.1559.185.0/10	1	bushing
21	0.007.1179.3/20		gear z = 57
			- WITH GREEN IDENTIFICATION STAMP
21.2	2.1559.185.0/10	1	bushing
22	2.1559.398.0	1	bushing 10.5x13x12

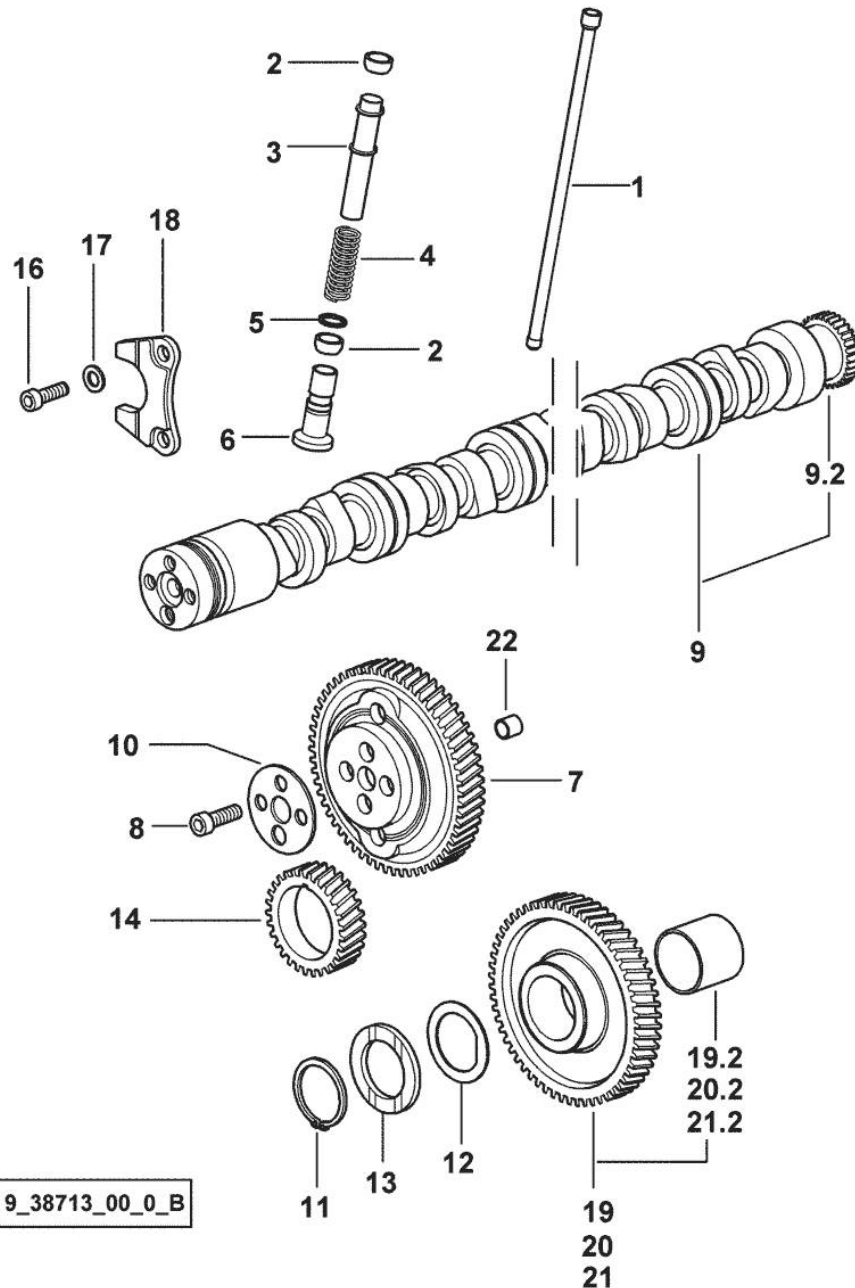

9\_38713\_00\_0\_B

Section: ENGINE  
CYLINDER HEAD

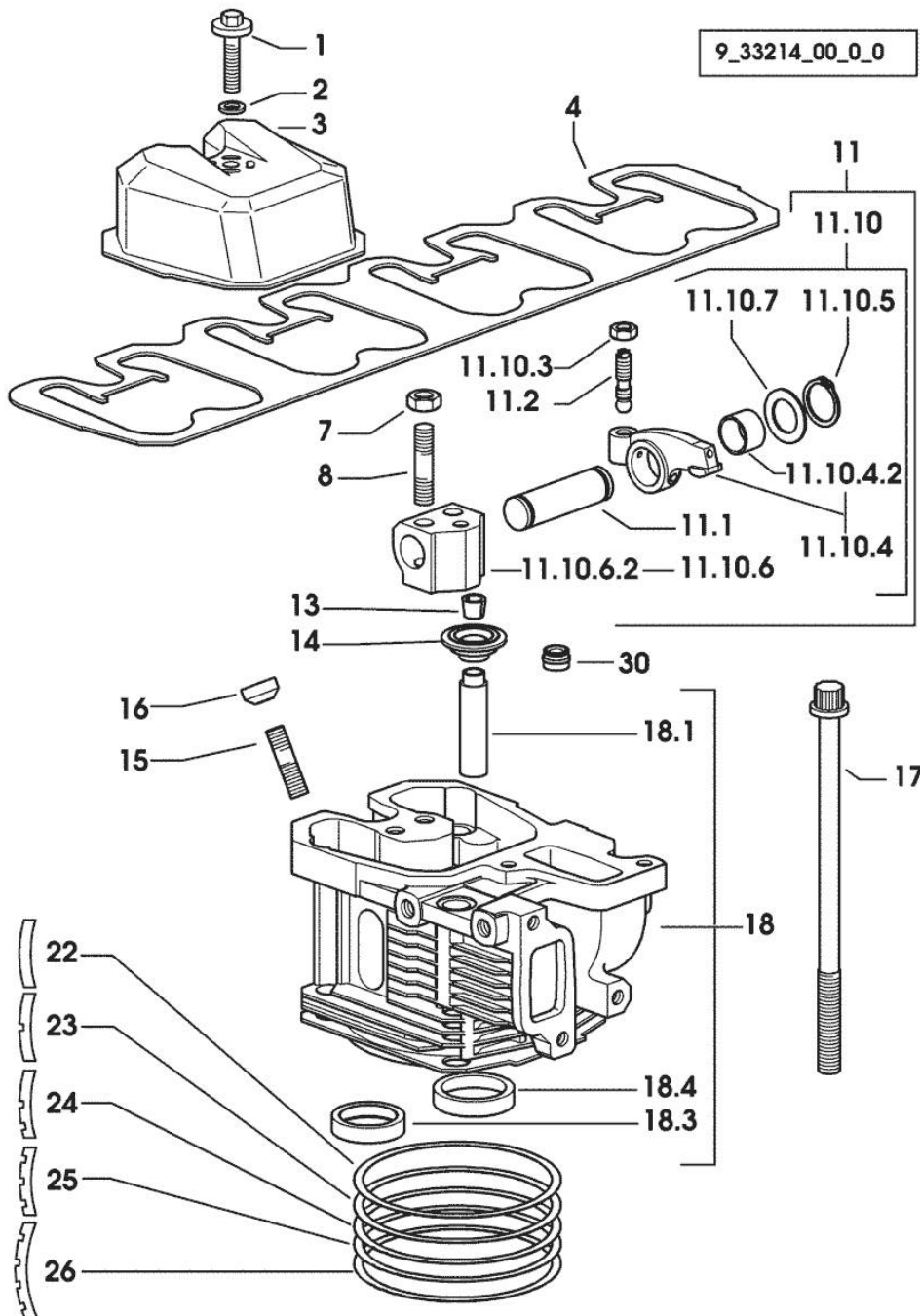

Fig.	P/n	QTY	Name
------	-----	-----	------

Notes:  
[ROCK 70 M]

1	2.0399.130.2/10	4	screw m 8x36x44 1328 <- X ROCK 70
1	2.0399.288.2/10	4	screw m 8x36x46 -> 1329 X ROCK 70
2	2.1539.151.0	4	special oil seal 9.19 x 2.62 -> 1329 X ROCK 70
2	2.1569.170.0/10	4	gasket 8.2 x 14 1328 <- X ROCK 70
3	0.007.1139.0/10	4	small cap
4	0.065.1450.0/30	1	tappet gasket
7	2.1011.421.2	8	nut m 10 p.1.25
8	2.0432.163.7	8	stud bolt m 10 p.1.5 / p.1.25 x 45
11	0.000.0000.1		cannot be supplied
11.1	0.066.1431.0	1	pin
11.2	0.021.1434.0	2	screw
11.10	0.000.0000.1		cannot be supplied
11.10.3	2.1011.405.2	2	nut m 8 p.1
11.10.4	0.066.1432.3	2	rocker arm
11.10.4.2	2.1559.021.0/40	1	bushing 15x19x22
11.10.5	2.1410.055.7	2	circlip 19
11.10.6	0.000.0000.1		cannot be supplied
11.10.6.2	0.066.1430.0/10	1	support
11.10.7	2.1599.432.0	2	shoulder ring
13	0.074.1423.0	16	conical valve cotter
14	0.066.1425.0	8	cup
15	2.0432.161.7	4	stud bolt m 10 p.1.5 / p.1.25 x 40
16	0.007.1122.0/10	4	bush L = mm 6.4
17	0.065.1443.0/20	16	screw
18	0.007.1110.3/60	4	engine head
18.1	0.007.1779.0/20	2	valve guide
18.3	0.066.1427.0	1	valve seat
18.4	0.078.1426.0	1	valve seat
22	0.085.1450.0/10		head gasket mm 0.50
23	0.085.1451.0/10	3	head gasket mm 0.7
24	0.085.1452.0/10	1	head gasket mm 1.0
25	0.085.1453.0/10	3	head gasket mm 0.8
26	0.013.4598.0	3	head gasket mm 1.3
30	2.1519.117.0	8	special oil seal

Thank you so much for reading.  
Please click the “Buy Now!”  
button below to download the  
complete manual.



After you pay.

You can download the most  
perfect and complete manual in  
the world immediately.

Our support email:

[ebooklibonline@outlook.com](mailto:ebooklibonline@outlook.com)