

Section: ENGINE
CRANKCASE

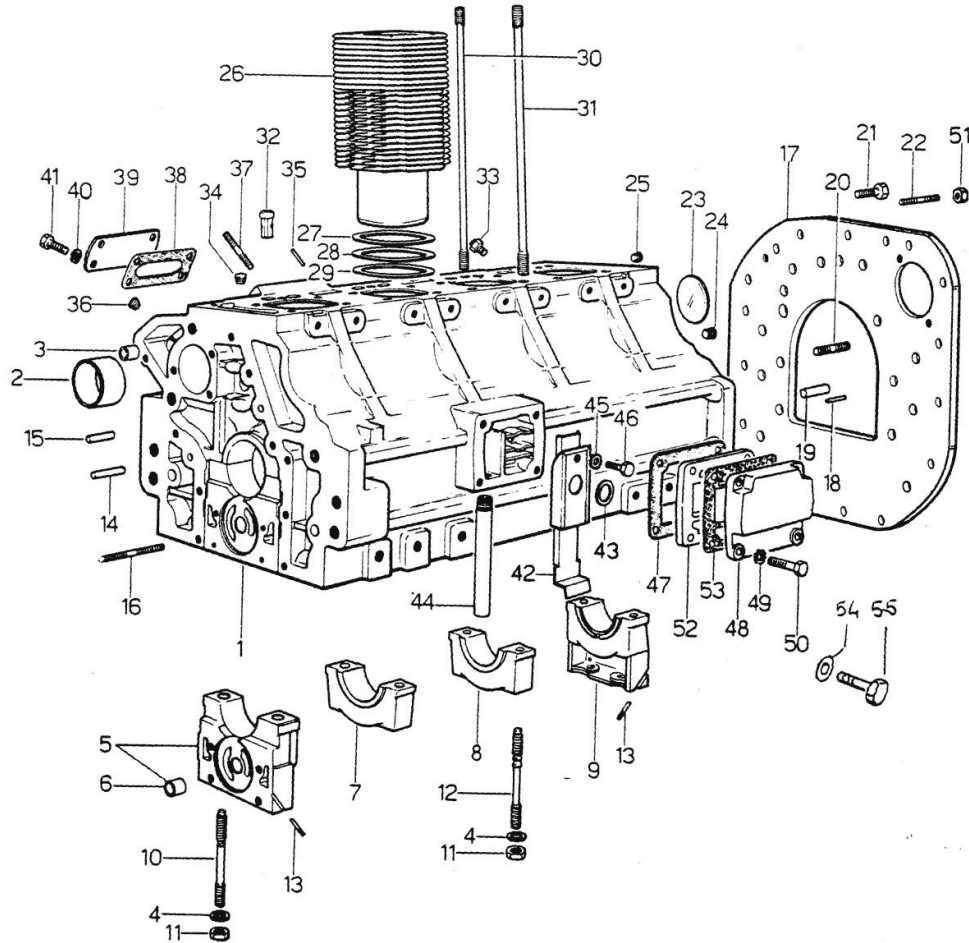

Fig.	P/n	QTY	Name
------	-----	-----	------

Notes:
 [ROW CROP 80]

0	0.044.0050.6	1	gasket set - FOR ENGINE MOUNTING
1	0.044.1110.4/50	1	crankcase 29372 <-
1	0.045.1110.4	1	crankcase -> 29373
2	0.037.1155.0	1	bushing
3	2.1559.111.0/10	2	special bushing 11.5x14.1x10
4	2.1599.144.7	10	shoulder ring 12.5x23x4
5	0.036.1112.6	1	support
6	2.1559.090.0/10	1	bushing 14.24x19.06x27
7	0.037.1114.0	1	support
8	0.029.1113.0	2	support
9	0.029.1116.0	1	support
10	0.021.1157.0	4	stud bolt
11	2.1019.026.7	10	special nut m 12 p.1.5
12	0.029.1117.0	6	stud bolt
13	0.029.1154.0	4	gasket
14	2.1699.114.0	1	pin 8x55
15	2.1653.711.0	1	pin
16	2.0432.025.1	2	stud bolt m 8 p 1.25-1x100
17	0.044.1130.0	1	flange
18	2.1653.708.0	2	pin 8x18
19	2.1652.911.0	2	cylindrical plug 12x25
20	2.0432.153.1	2	stud bolt m 10 p.1.5 / p.1.25 x 20
21	2.0112.511.1	11	screw m 14 p.2 x 30
22	2.0432.255.1	2	stud bolt m 12 p.1.75 - 12 p1.25x25
23	2.3170.022.1	1	expansion plug 60
24	2.3130.003.1	2	plug 3/8" gas
25	2.3130.002.1	1	plug 1/4" gas
26	0.044.1120.0/10	4	engine cylinder
27	2.1589.052.0	8	shoulder ring 115x123x0.2
28	2.1589.051.0	4	shoulder ring 116x123x0.1
29	2.1569.076.0	4	gasket 116x123x0.5
30	0.041.1123.0	4	stud bolt m 10
31	0.039.1122.0	16	stud bolt m 12 p.1.5x310
32	0.044.1156.0	8	special bushing
33	0.041.1151.3/10	4	sprayer nozzle
34	2.3130.001.1	4	plug 1/8" gas
35	2.1653.507.0	2	pin
36	2.3139.001.1	5	plug

Section: ENGINE
CRANKCASE

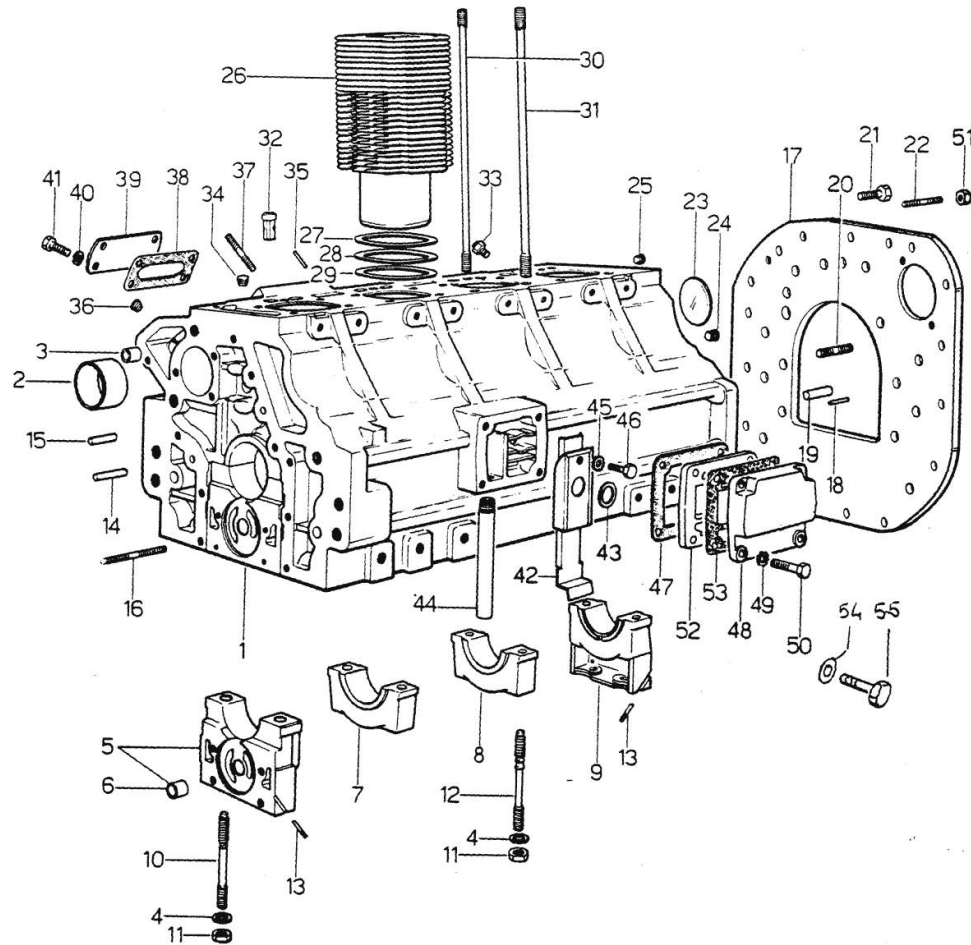

Fig.	P/n	QTY	Name
37	2.0432.003.1	4	stud bolt m 8 p.1.25 / p.1 x 20
38	0.044.1151.0	1	gasket
39	0.044.1150.0	1	cover
40	2.1310.004.2	4	flat washer 8.4x17
41	2.0112.204.2	4	screw m 8 p.1.25x14
42	0.044.1162.2	1	small guard -> 29373
42	0.045.1151.2/20	1	cover 29372 <-
43	0.045.1150.0	1	oil seal
44	0.044.1152.0	1	tube
45	2.1474.009.1	1	spring washer 8
46	2.0312.206.2	1	screw m 8 p 1.25 x 20
47	0.044.1153.0/10	1	gasket
48	0.044.1163.0	1	cover
49	2.1474.009.1	4	spring washer 8
50	2.0112.211.2	4	screw m 8 p.1.25 x 30
51	2.1011.207.2	2	nut m 12 p.1.5
52	0.044.1160.0	1	container
53	0.044.1161.0	1	gasket
54	2.1310.004.2	1	flat washer 8.4x17
55	2.0112.204.2	1	screw m 8 p.1.25x14

Section: ENGINE
TIMING CASE

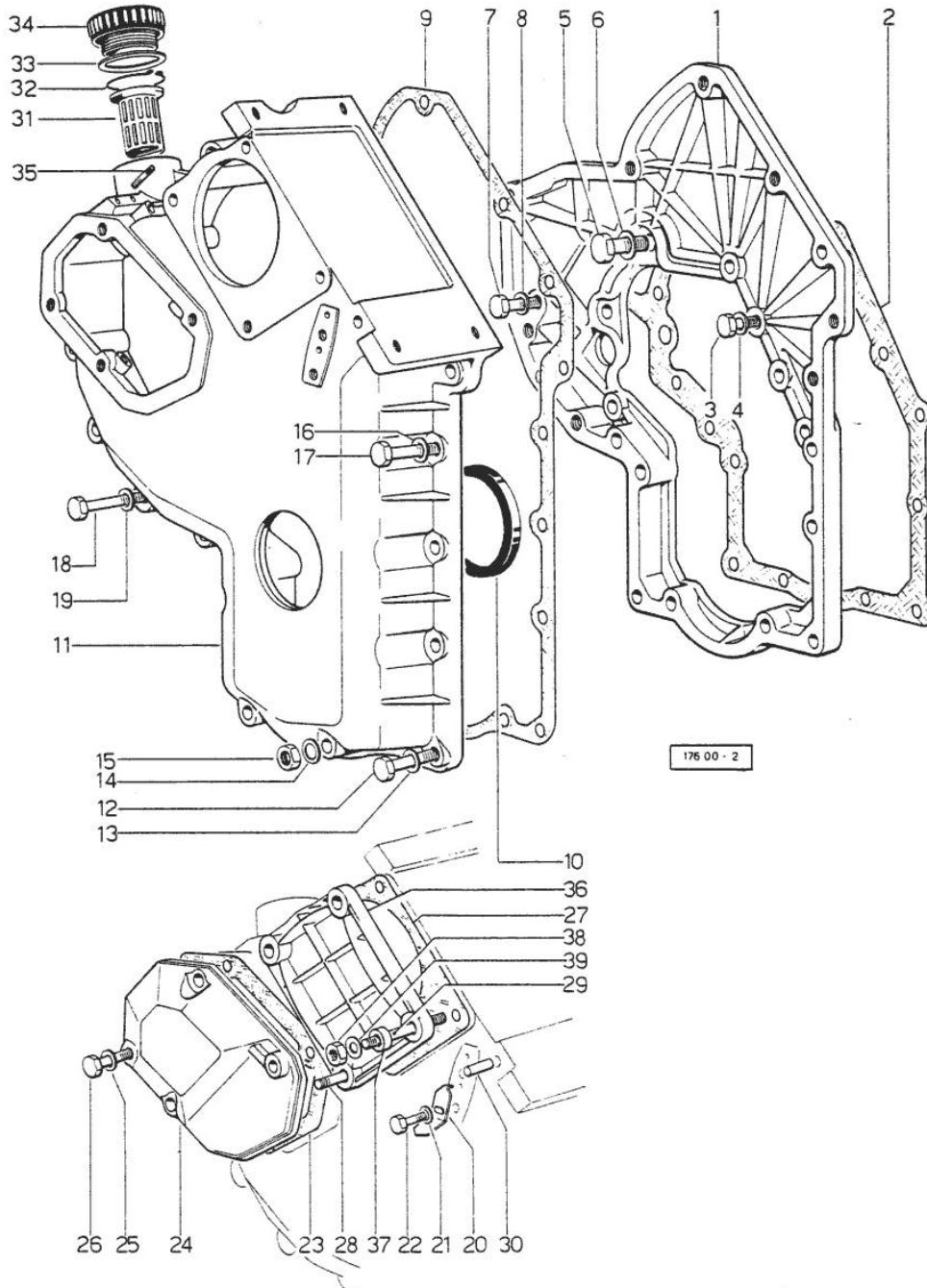

Fig.	P/n	QTY	Name
------	-----	-----	------

Notes:
[ROW CROP 80]

1	0.048.1131.0	1	flange
2	0.041.1153.0	1	gasket
3	2.0112.209.2	5	screw m 8 p 1.25 x 25
4	2.1474.009.1	5	spring washer 8
5	2.0119.034.1	1	screw m 14 p.2x20
6	2.1560.010.0	1	gasket 14.2 x 20
7	2.0112.207.2	1	screw m 8 p 1.25 x 20
8	2.1474.009.1	1	spring washer 8
9	0.041.1152.0	1	gasket
10	2.1519.010.0	1	special oil seal 58x80x10
11	0.048.1132.0/10	1	guard 27009 <=
11	0.048.1132.0/30	1	guard => 27010
12	2.0112.217.2	5	screw m 8 p.1.25 x 45
13	2.1474.009.1	5	spring washer 8
14	2.1560.003.0	2	copper gasket 8.2 x 12
15	2.1011.405.2	2	nut m 8 p.1
16	2.1474.009.1	2	spring washer 8
17	2.0112.211.2	2	screw m 8 p.1.25 x 30
18	2.0112.222.2	4	screw m 8 p.1.25x65
19	2.1474.009.1	4	spring washer 8
20	0.027.1150.0/10	1	index 29372 <-
20	0.041.1158.0	1	index -> 29373
21	2.1310.004.2	1	flat washer 8.4x17
22	2.0112.204.2	1	screw m 8 p.1.25x14
23	0.048.1152.0	1	gasket
24	0.048.1150.0/10	1	old part number
25	2.1560.005.0	4	copper gasket 10.2 x 14
26	2.0112.315.2	4	screw m 10 p.1.5 x 40
27	0.041.1154.0	1	gasket
28	2.0432.015.1	1	stud bolt m 8 p 1.25 - m 8 p. 1x50
29	2.0432.028.1	3	stud bolt m 8 p.1.25-1x130
30	2.1653.717.0	1	pin 8 x 40
31	0.041.1159.0/10	1	filter
32	2.1411.012.1	1	circlip 30
33	2.1569.072.0	1	gasket 32 x 39.5 x 2
34	0.041.1135.0	1	plug
35	2.0119.081.2	2	screw

Section: ENGINE

TIMING CASE

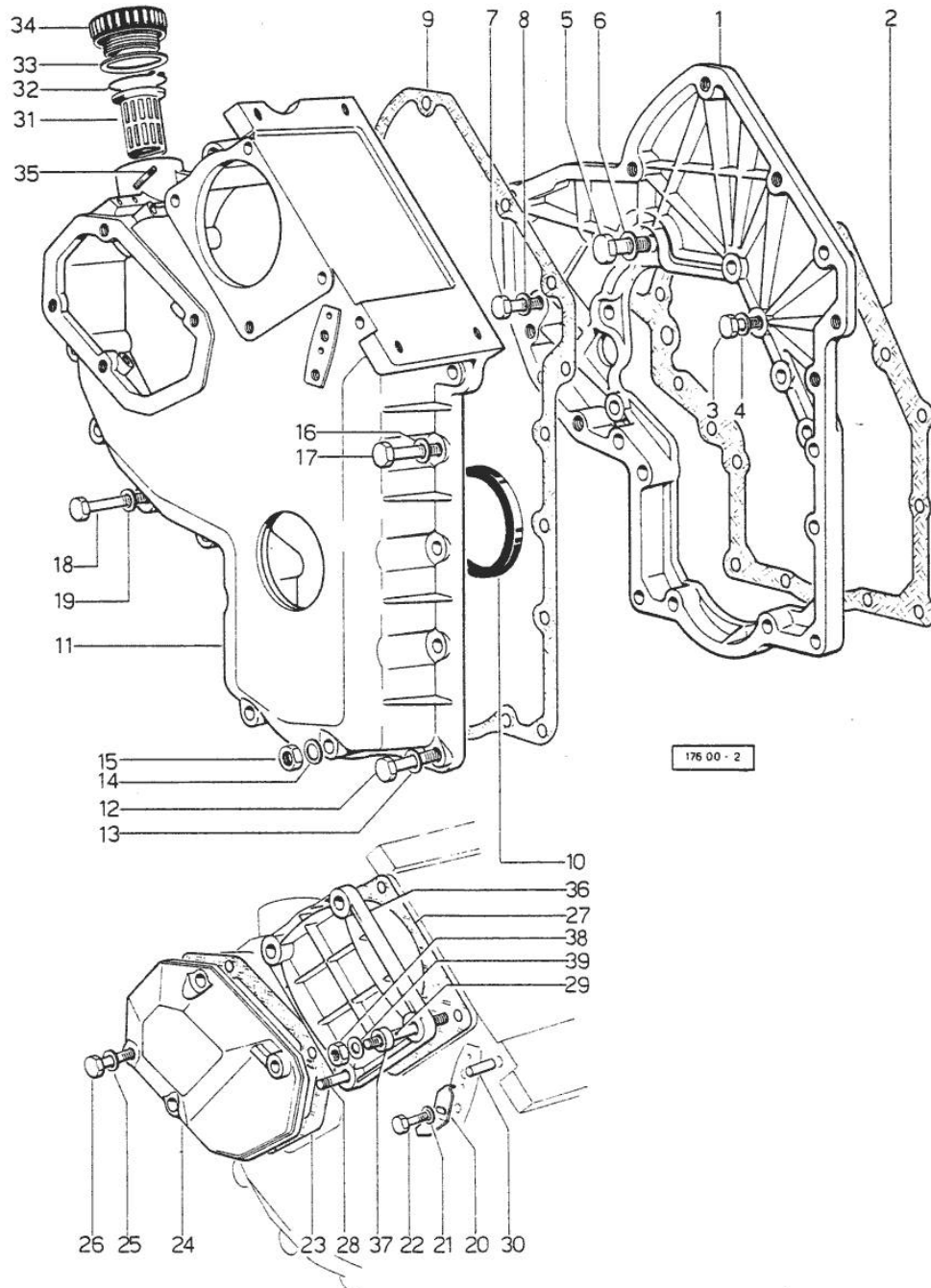

Fig.	P/n	QTY	Name
36	0.037.1151.0	1	cover
37	2.1579.191.0	4	spacer 8.5 x 18 x 20
38	2.1011.505.2	4	nut m 8 p.1
39	2.1310.004.2	4	flat washer 8.4x17

Section: ENGINE

CRANKSHAFT

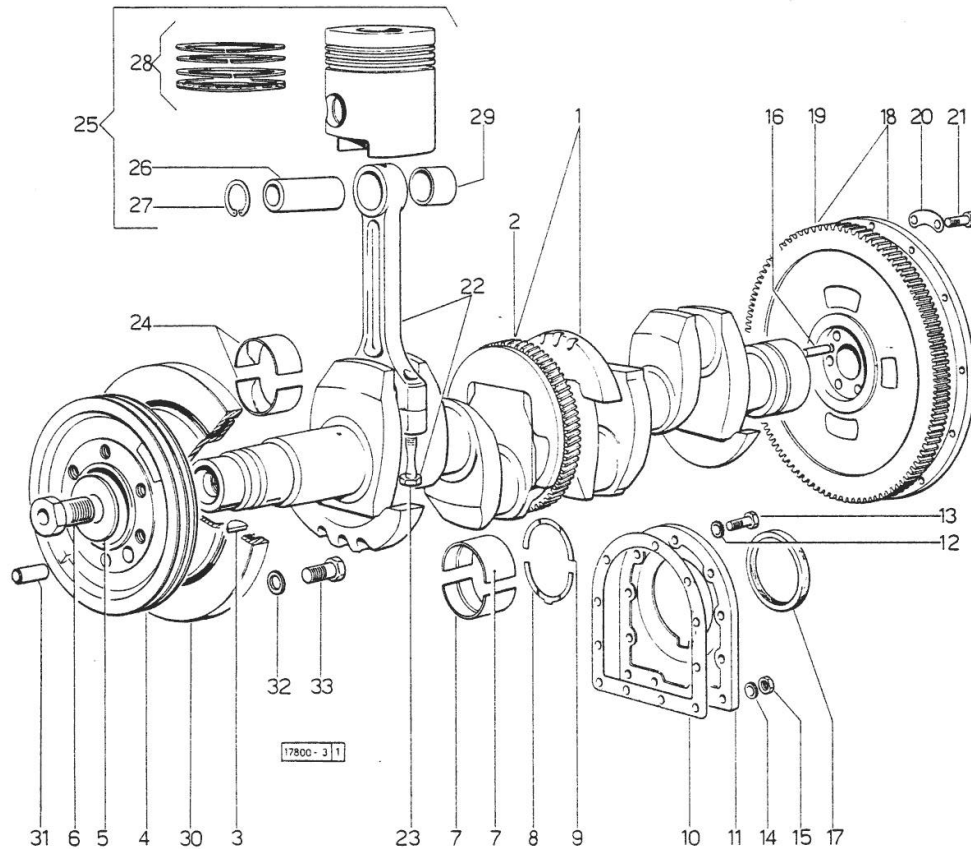

Fig.	P/n	QTY	Name
------	-----	-----	------

Notes:
[ROW CROP 80]

1	0.044.1210.4/10	1	crankshaft 29372 <-
1	0.044.1267.4/20	1	crankshaft -> 29373
1	0.044.167.3/20	1	- -> 29373
1	2.1652.611.0	1	- -> 29373
2	0.044.1251.0	1	gear 29372 <-
2	0.044.1265.0/20	1	gear -> 29373
3	2.1799.002.0	1	stick 10x13
4	0.044.1253.0	1	pulley 29372 <-
4	0.054.1250.0	1	pulley -> 29373
5	0.001.6020.0	1	shoulder
6	2.0129.032.2	1	screw m 24 p.2x45
7	0.029.0066.0	10	main half bushing - mm 1.00
7	0.029.1215.0/10	10	main half bushing
7	0.029.1215.7	10	main half bushing - mm 0.25
7	0.029.1215.8	10	main half bushing - mm 0.50
7	0.029.1215.9	10	main half bushing - mm 0.75
8	0.001.4547.0	2	shoulder ring + mm 0.05
8	0.001.4548.0	2	shoulder ring + mm 0.10
8	0.001.4549.0	2	shoulder ring + mm 0.15
8	0.042.1219.0	2	shoulder ring STANDARD
9	0.001.4544.0	2	shoulder ring + mm 0.05
9	0.001.4545.0	2	shoulder ring + mm 0.10
9	0.001.4546.0	2	shoulder ring + mm 0.15
9	0.042.1218.0	2	shoulder ring STANDARD
10	0.029.1250.0	1	gasket
11	0.029.1240.0	1	flange
12	2.1474.010.1	7	spring washer 10
13	2.0112.309.2	7	screw m 10 p.1.5 x 25
14	2.1560.006.0	2	gasket 10.2 x 16
15	2.1011.421.2	2	nut m 10 p.1.25
16	2.1652.915.0	2	cylindrical plug 12x35
17	2.1519.009.0	1	special oil seal
18	0.039.1241.3/10	1	flywheel

Section: ENGINE
CRANKSHAFT

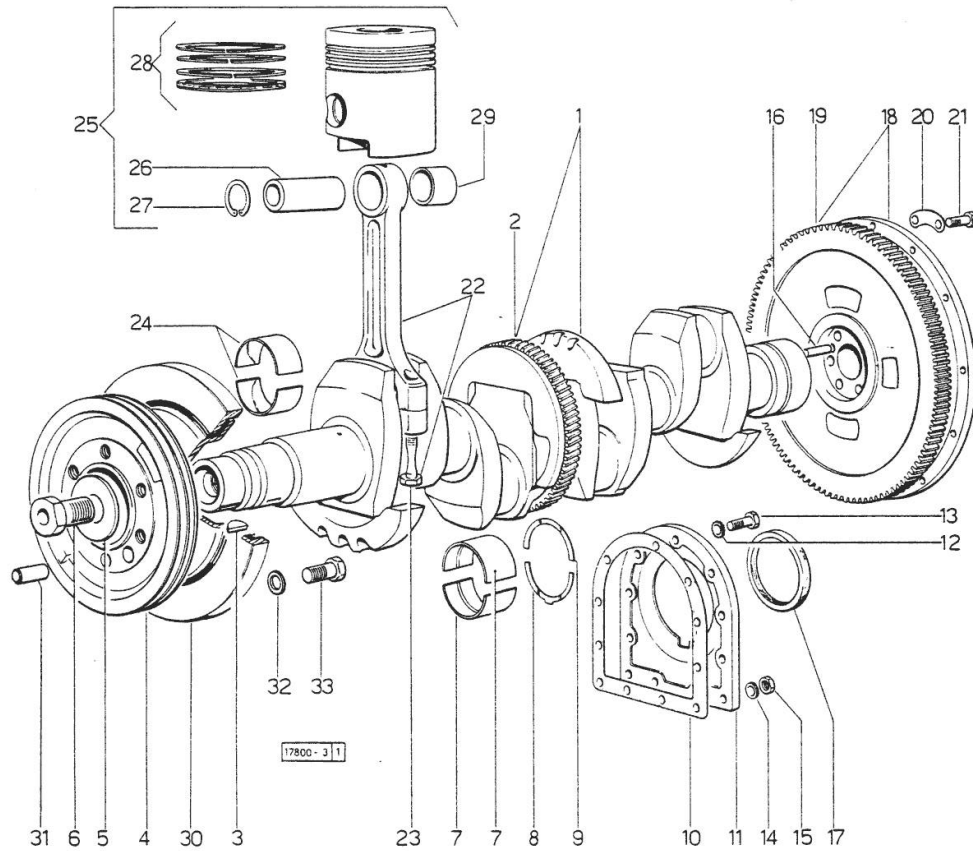

Fig.	P/n	QTY	Name
19	0.036.1242.0	1	crown wheel Z = 126, mm 15
20	2.1379.006.0	3	lock-tab 15x15x36,5
21	2.0122.515.7	6	screw
22	0.052.1220.3	4	engine connecting rod
23	0.039.1250.0	8	screw m 14 p.1.5x63
24	0.039.0068.0	8	con.rod half bushing - mm 1.016
24	0.039.1225.0	8	con.rod half bushing
24	0.039.1225.7	8	con.rod half bushing -mm 0.254
24	0.039.1225.8	8	con.rod half bushing -mm 0.508
24	0.039.1225.9	8	con.rod half bushing -mm 0.762
25	0.046.0060.6	4	complete piston
25	0.046.0061.6	4	complete piston + mm 0.5
25	0.046.0062.6	4	complete piston + mm 1.0
26	0.038.1236.0	4	piston pin
27	2.1411.014.1	8	circlip 35
28	0.054.0052.6	4	piston ring set
28	0.054.0053.6	4	piston ring set + mm 0.5
28	0.054.0054.6	4	piston ring set + mm 1.0
29	0.002.4168.0	4	bearing
30	0.044.1246.3	1	antivibration pulley
31	2.1652.909.0	1	cylindrical plug 12x20
32	2.1474.011.1	6	spring washer 12
33	2.0122.457.2	6	screw m 12 p.1.25 x 20

Section: ENGINE

CRANKSHAFT - HARMONIC BALANCER 29372 <=

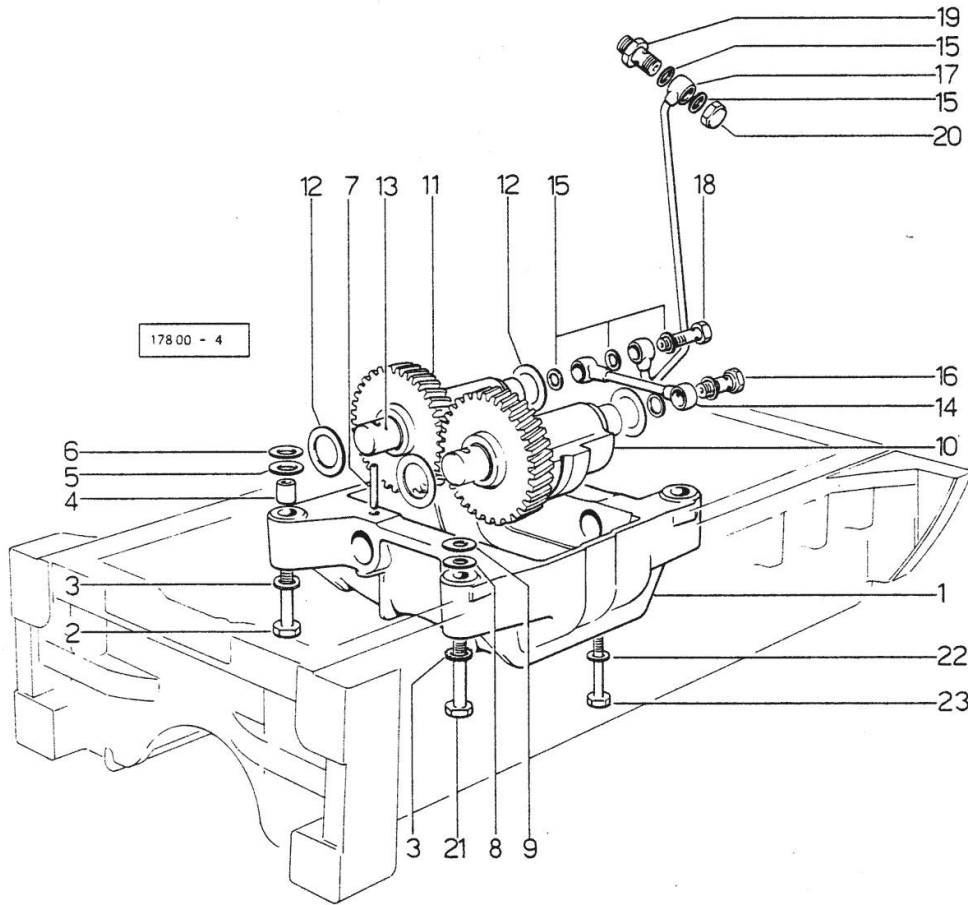

Fig.	P/n	QTY	Name
------	-----	-----	------

Notes:
[ROW CROP 80]

1	0.044.1254.0	1	support
2	2.0112.420.1	2	screw m 12 p.1.75x55
3	2.1330.007.0	4	lock-tab 13
4	2.1579.626.0	2	spacer 13.2x16x11
5	2.1579.628.0	2	spacer 16.5x26x0.1
6	2.1589.048.0	2	shoulder ring 16.5x26x0.3
7	2.1630.715.0	2	roll pin 8 x 40
8	2.1589.049.0	2	shoulder ring 12.5x26x0.3
9	2.1579.629.0	2	spacer 12.5x26x0.1
10	0.044.1256.3/10	1	mass sx/lh/li
10	2.1559.115.0	2	special bushing 26x30x30
11	0.044.1255.3/10	1	mass dx/rh/re
11	2.1559.115.0	2	special bushing 26x30x30
12	2.1589.050.0	4	shim
13	0.044.1258.0	2	pin
14	0.319.1550.3	1	tube
15	2.1560.007.0	7	gasket 12.2x16
16	2.3332.003.1	1	pipe union m 12 p.1.25
17	0.044.1551.2	1	tube
18	2.3339.515.1	1	pipe union m 12 p.1.25
19	2.3319.041.1	1	pipe union m 12 p.1.25-p.1.75
20	2.1019.048.1	1	special nut m 12 p.1.5
21	2.0112.421.2	2	screw m 12 p.1.75 x 60
22	2.1474.009.1	1	spring washer 8
23	2.0112.204.2	1	screw m 8 p.1.25x14

CRANKSHAFT - HARMONIC BALANCER => 29373

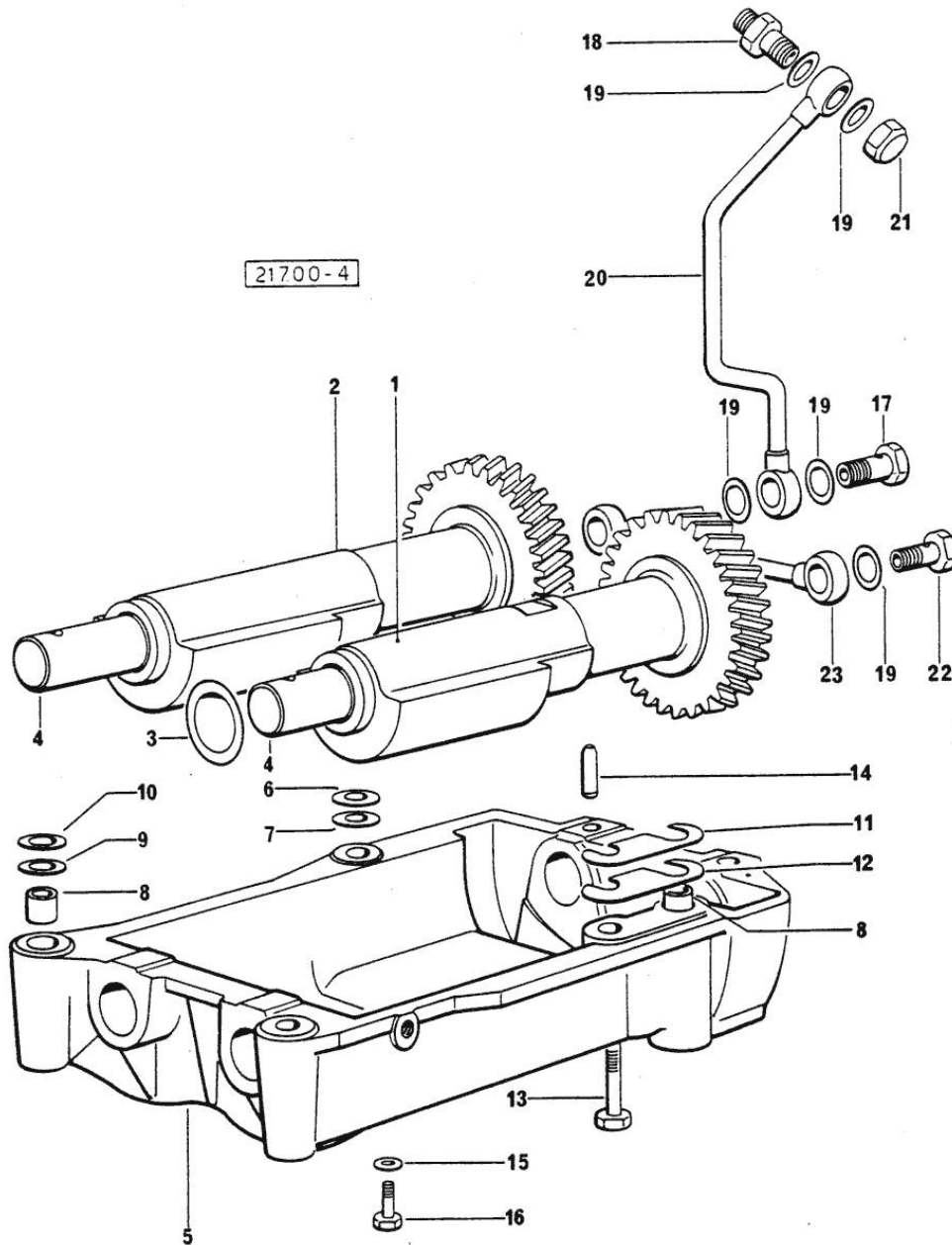

Fig.	P/n	QTY	Name
------	-----	-----	------

Notes:
[ROW CROP 80]

1	0.044.1263.3/20	1	mass sx/lh/li
1	2.1559.115.0	2	special bushing 26x30x30
2	0.044.1261.3/10	1	mass dx/rh/re
2	2.1559.115.0	2	special bushing 26x30x30
3	2.1589.050.0	4	shim
4	0.044.1266.0/20	2	shaft
5	0.044.1260.0/30	1	support
6	2.1589.049.0	2	shoulder ring 12.5x26x0.3
7	2.1579.629.0	2	spacer 12.5x26x0.1
8	2.1579.626.0	2	spacer 13.2x16x11
9	2.1579.628.0	1	spacer 16.5x26x0.1
10	2.1589.048.0	1	shoulder ring 16.5x26x0.3
11	2.1379.038.0	2	shim mm 0.1
12	2.1379.038.0	1	shim mm 0.1
13	2.0112.426.1	2	screw m 12 p.1.75x85
14	2.1631.717.0	2	roll pin 8 x 40
15	2.1474.009.1	2	spring washer 8
16	2.0112.204.2	2	screw m 8 p.1.25x14
17	2.3339.515.1	1	pipe union m 12 p.1.25
18	2.3319.041.1	1	pipe union m 12 p.1.25-p.1.75
19	2.1560.007.0	7	gasket 12.2x16
20	0.044.1562.2	1	tube
21	2.1019.048.1	1	special nut m 12 p.1.5
22	2.3332.003.1	1	pipe union m 12 p.1.25
23	0.319.1550.3	1	tube

Section: ENGINE

CAMSHAFT

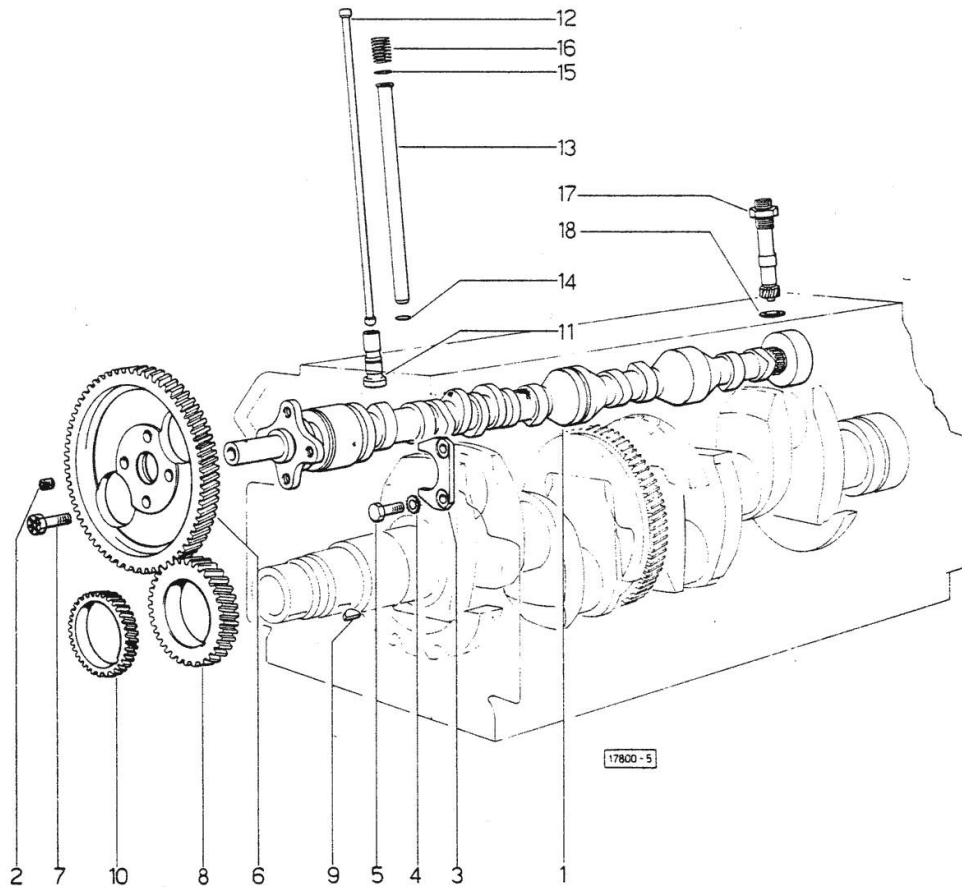

Fig.	P/n	QTY	Name
------	-----	-----	------

Notes:
[ROW CROP 80]

1	0.044.1310.0/30	1	camshaft
2	2.3130.001.1	1	plug 1/8" gas
3	0.027.1314.0	1	flange
4	2.1470.004.2	2	lock washer 8
5	2.0112.207.2	2	screw m 8 p 1.25 x 20
6	0.041.1321.0	1	gear z = 66
7	2.0139.005.1	4	screw m 10 p.1 x 25
8	0.040.1320.0	1	gear z = 33
9	2.1720.010.0	1	key 5x9
10	0.040.1323.0/10	1	gear Z = 38
11	0.044.1330.0/10	8	tappets
12	0.041.1331.3	8	rod
13	0.041.1332.0	8	sleeve
14	2.1539.020.0	8	special oil seal 13.95x2.62
15	2.1539.019.0	8	oil seal
16	2.4019.162.1/20	8	spring 17.2x46x1.8
17	0.041.1355.3	1	transmission
18	2.1560.013.0	1	gasket 18.2x22

Section: ENGINE
CYLINDER HEAD

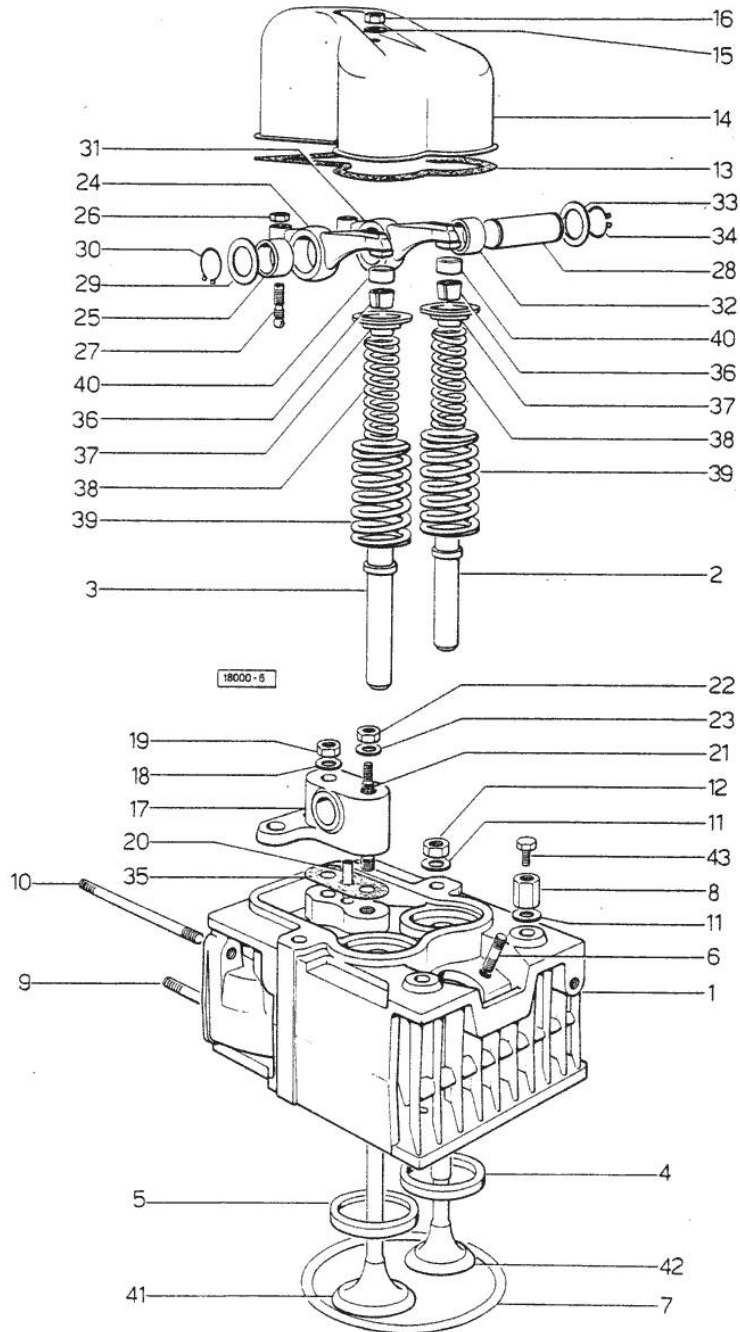

Fig.	P/n	QTY	Name
Notes:			
[ROW CROP 80]			
0	0.042.0057.6	1	gasket set
0	0.042.0058.6	1	gasket set
- FOR 1 CYLINDER VALVE GRINDING AND PISTON RINGS REPLACEMENT			
1	0.044.1450.3/50	4	engine head
2	0.037.1417.0/10	4	valve guide
3	0.037.1416.0	4	valve guide
4	0.037.1452.0/10	4	valve seat
5	0.037.1451.0/10	4	valve seat
6	2.0439.087.1	8	stud bolt
7	2.1569.078.0/10	4	gasket 106x118x0.5
8	2.1019.037.0	6	special nut m 12 p.1.5
9	2.0432.007.1	3	stud bolt m 8 p.1.25 / p.1 x 30
10	2.0432.007.1	4	stud bolt m 8 p.1.25 / p.1 x 30
11	2.1599.406.0	16	shoulder ring
12	2.1019.025.0	10	special nut m 12 p.1.5
13	0.029.1450.0	4	gasket
14	0.039.1440.0	4	cap
15	2.1560.004.0	4	copper gasket 8.2 x 14
16	2.1099.056.1	4	special nut m8 p.1
17	0.041.1430.0	4	support
18	2.1599.160.0	16	washer 10.5x19x4
19	2.1099.035.0	16	special nut m 10 p.1.25
20	0.029.1452.0	4	tube
21	0.039.1451.0	4	stud bolt
22	2.1011.421.2	4	nut m 10 p.1.25
23	2.1310.006.2	4	flat washer 10.5x21
24	0.002.5937.3/30	4	rocker arm
25	2.1559.021.0/40	4	bushing 15x19x22
26	2.1011.405.2	8	nut m 8 p.1
27	0.021.1434.0	8	screw
28	0.041.1431.0	4	pin
29	2.1599.019.0	4	shoulder ring 19.5x31x2
30	2.1410.055.1	4	circlip 19
31	0.002.5936.3/40	4	rocker arm
32	2.1559.021.0/40	4	bushing 15x19x22
33	2.1599.019.0	4	shoulder ring 19.5x31x2
34	2.1410.055.1	4	circlip 19
35	0.034.1450.0	4	tappet gasket
36	0.002.9193.0/10	8	conical valve cotter cup
37	0.002.9215.0/10	8	cup

Section: ENGINE
CYLINDER HEAD

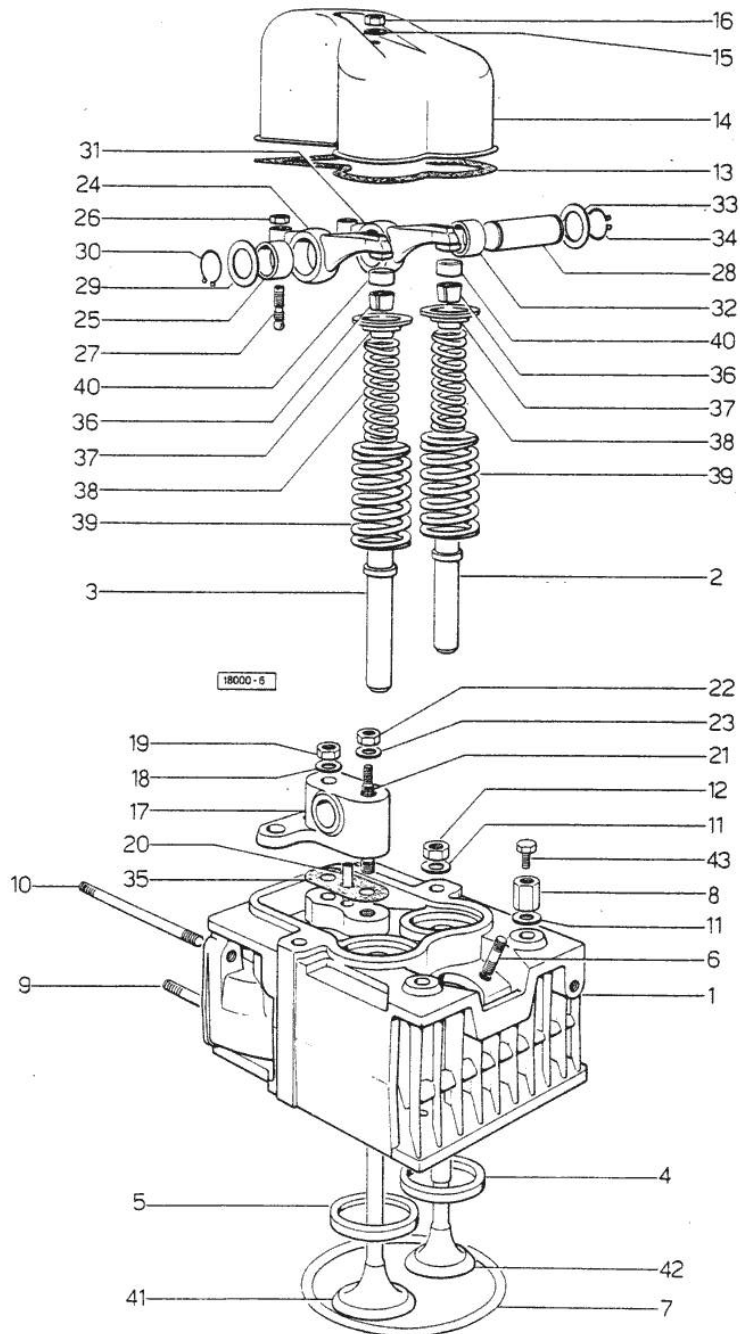

Fig.	P/n	QTY	Name
38	2.4019.194.0	8	spring 22.70x50.7x2.1
39	2.4019.193.0	8	spring 36.15x55.2x3.2
40	0.021.1453.0/20	8	small cover
41	0.052.1420.0	4	inlet valve Ø mm 9
42	0.039.1421.0	4	exhaust valve Ø mm 9
43	2.0119.053.1	2	screw

Thank you so much for reading.
Please click the “Buy Now!”
button below to download the
complete manual.



After you pay.

You can download the most
perfect and complete manual in
the world immediately.

Our support email:

ebooklibonline@outlook.com