

AIR COMPRESSOR

Fig.	P/n	QTY	Name
------	-----	-----	------

Notes:

[SILVER³ 100 CONTINUO]

1.1	04428408.4	1	air compressor 229 cm ³ ☞ 04428408.4																												
1.2	04295536	1	gear Z = 43																												
2	2.1475.003.2	3	washer 10																												
3	2.0112.311.2	3	screw m 10 p.1.5 x 30																												
4	0.014.8296.3	1	tube																												
5	2.1560.010.0	2	gasket 14.2 x 20																												
6	2.3335.006.2	1	pipe union m 14 p.1.5X26																												
7	2.1560.005.0	2	copper gasket 10.2 x 14																												
8	2.3339.074.2	1	pipe union m 10 p.1x19	9	0.014.9049.3	1	tube	10	2.0112.205.2	1	screw m 8 p.1.25 x 16	11	2.1310.004.2	1	flat washer 8.4x17	12	2.1569.068.0	2	gasket 26.3x34	13	2.3335.010.2	1	pipe union m 26x1.5	14	0.014.9301.0	1	tube	15	2.6851.003.0	2	clamp Ø 25/40
9	0.014.9049.3	1	tube																												
10	2.0112.205.2	1	screw m 8 p.1.25 x 16																												
11	2.1310.004.2	1	flat washer 8.4x17																												
12	2.1569.068.0	2	gasket 26.3x34																												
13	2.3335.010.2	1	pipe union m 26x1.5																												
14	0.014.9301.0	1	tube																												
15	2.6851.003.0	2	clamp Ø 25/40																												

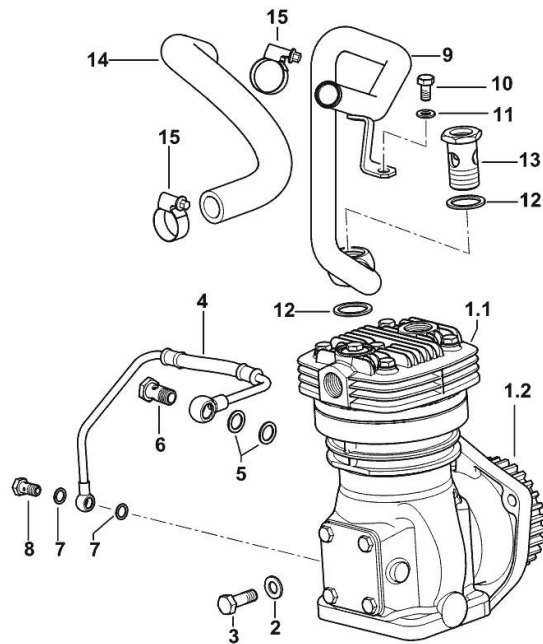

9_N9119_40_0-A-001

COMPRESSOR-PARTS

Fig.	P/n	QTY	Name
1	04428408.4	1	air compressor 229 cm ³
3	04436267	1	bushing
4	01151194	2	cover
5	04436268	1	cover
6	04436276	1	nut
7	04436269	1	piston
8	04436270	1	gasket
9	04436271	1	valve
10	04436272	1	thin plate
11	04436273	1	thin plate
13	04436275	1	cover
14	04436277	1	sub-assy parts
15	0.000.0000.1		cannot be supplied

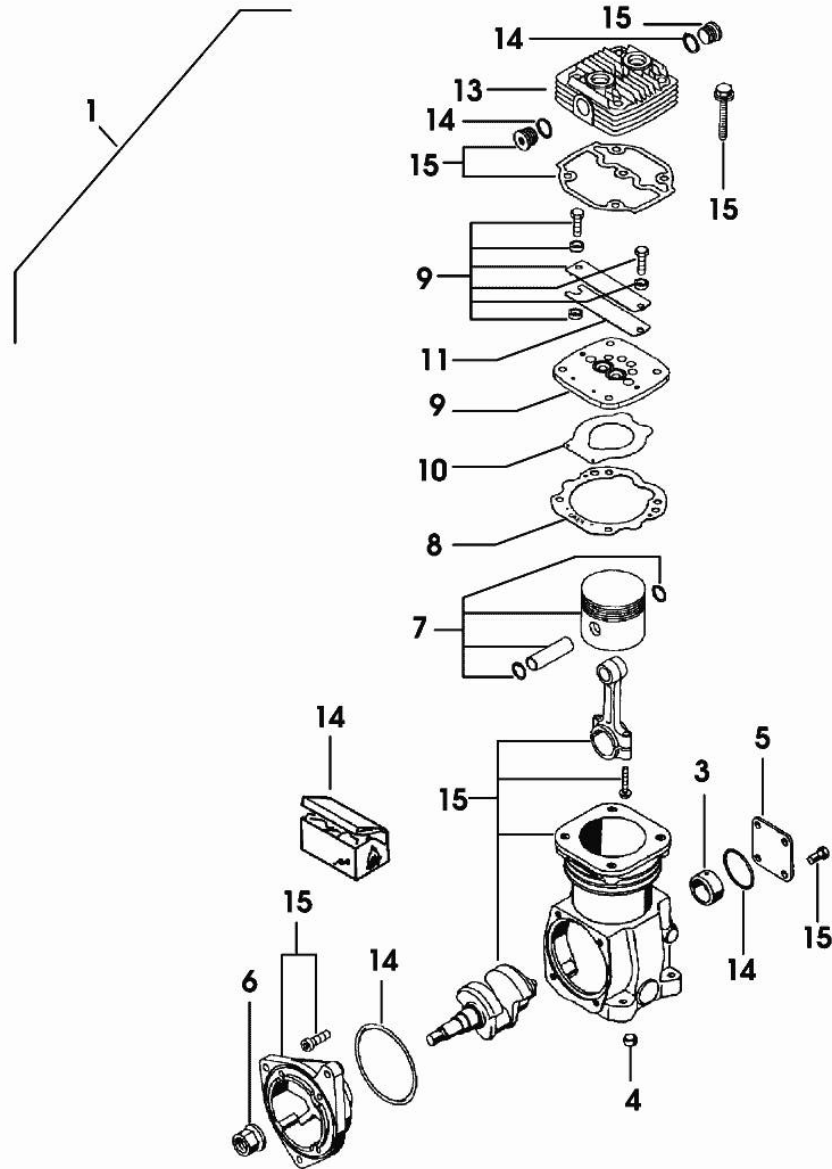

0442_6744_4

CLUTCH HOUSING

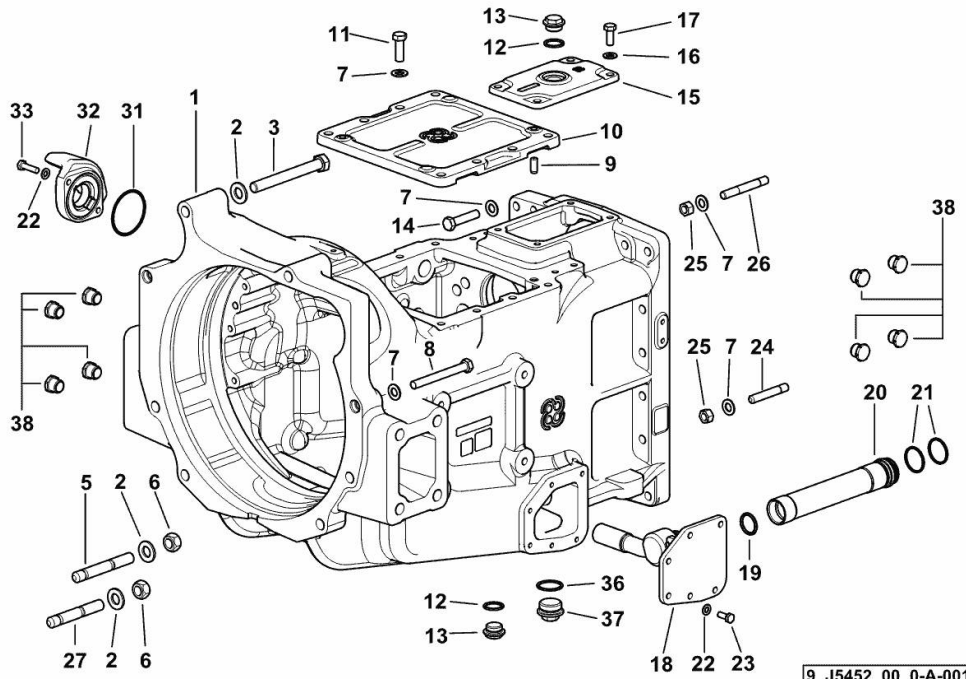

9_J5452_00_0-A-001

Fig.	P/n	QTY	Name
------	-----	-----	------

Notes:

[SILVER³ 100 CONTINUO]

1	0.015.7790.0/30	1	clutch housing
2	2.1475.006.2	6	spring washer 16
3	2.0113.637.2	2	screw m 16 p.2x140
5	2.0433.425.7	2	stud bolt m 16 p.1.5 x 100
6	2.1011.409.2	4	nut m 16 p.1.5
7	2.1475.004.2	29	spring washer 12
8	2.0113.431.2	2	screw m 12 p.1.75 x 110
9	2.1655.508.0	2	pin 10x24
10	0.015.4632.0/10	1	cover
11	2.0112.413.2	8	screw m 12 p.1.75x35
12	2.1560.019.0	2	copper gasket 24.3x30
13	2.3110.423.2	2	plug m 24 p.1.5x18.5
14	2.0112.420.2	12	screw m 12 p.1.75x55
15	0.015.4634.0/20	1	cover
16	2.1475.003.2	4	washer 10
17	2.0112.309.2	4	screw m 10 p.1.5 x 25
18	0.017.8211.3	1	tube
19	2.1530.070.0	1	oil seal
20	0.015.6320.0/10	1	tube
21	2.1532.091.0	2	ring 34.60 x 2.62
22	2.1475.002.2	8	conical washer 8
23	2.0112.207.2	6	screw m 8 p 1.25 x 20
24	2.0432.267.7	5	stud bolt m 12 p.1.75-1.25x60
25	2.1011.422.2	7	nut m 12 p.1.25
26	2.0432.270.7	2	stud bolt m 12 p.1,25 x 75 / m 12 p.1,75 x 18
27	2.0433.423.7	2	stud bolt m 16 p.1.5x90
31	2.1539.143.0	1	oil seal 64.77x2.62
32	0.016.1385.0	1	flange
33	2.0112.211.2	2	screw m 8 p.1.25 x 30
36	2.1560.056.0	1	gasket 33x39
37	2.3110.516.7	1	plug 1" gas
38	2.3199.363.0	8	plug m 20 p.2.5

FLEXIBLE COUPLINGS

Fig.	P/n	QTY	Name
------	-----	-----	------

Notes:[SILVER³ 100 CONTINUO]

1	0.014.0034.4	1	flexible coupling
2	2.1475.003.7	6	washer 10.5
3	2.0112.309.2	6	screw m 10 p.1.5 x 25

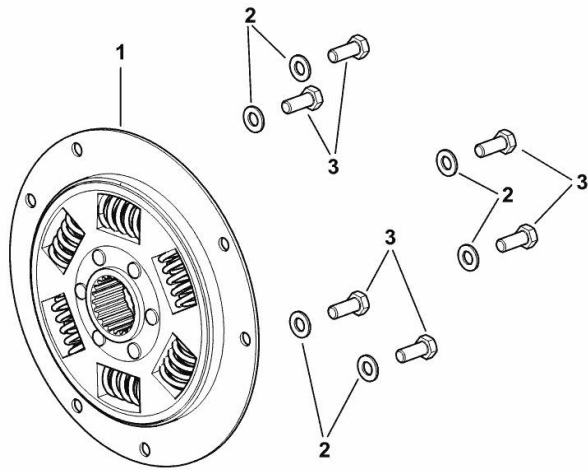

9_J5432_00_0-A-001

Section: D0 - TRANSMISSION
GEARBOX INPUT SHAFT

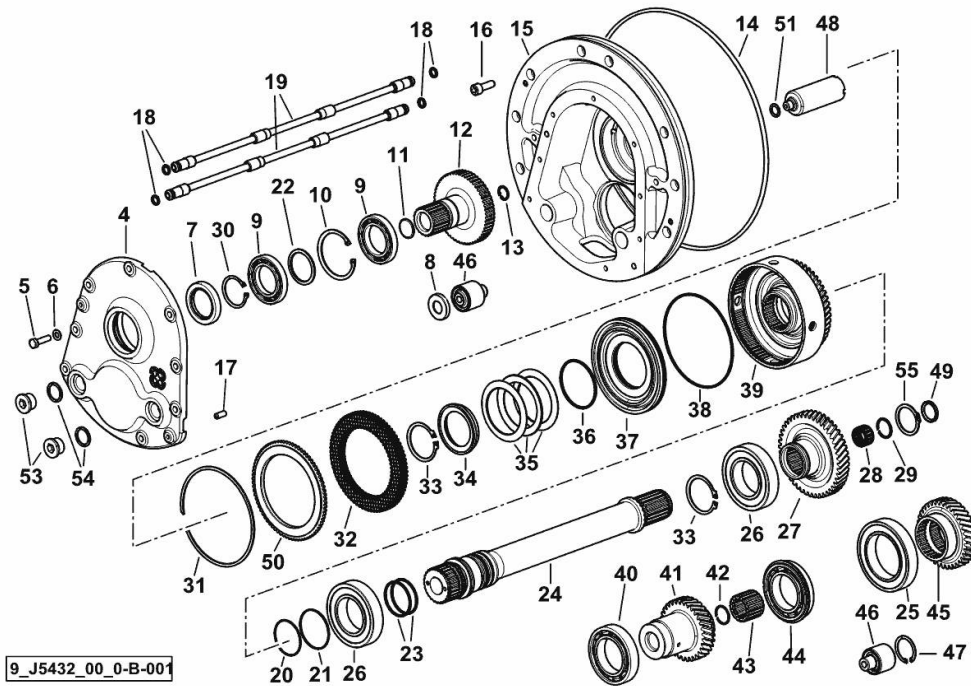
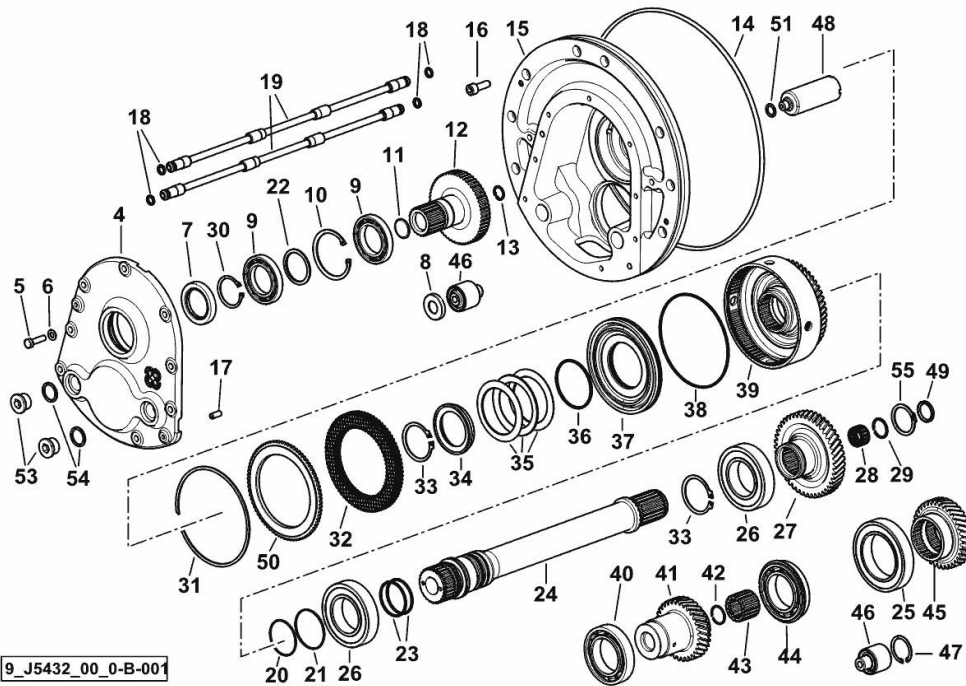

Fig.	P/n	QTY	Name
------	-----	-----	------

Notes:
 [SILVER³ 100 CONTINUO]

4	0.015.4306.0/20	1	cover
5	2.0112.211.2	8	screw m 8 p.1.25 x 30
6	2.1475.002.7	8	washer 8.4
7	2.1520.123.0	1	oil seal
8	0.015.4310.0	2	washer
9	2.2020.008.0	2	ball bearing 45x75x10
10	2.1411.030.7	1	circlip 75x2.5
11	2.3170.012.2	1	expansion plug Ø 30
12	0.013.4458.0/10	1	hub
13	2.1411.007.1	1	circlip 21
14	2.1539.228.0/10	1	oil seal
15	0.015.4283.3/40	1	cover (1069 <-)
15	0.015.4283.3/50	1	cover (-> 1070)
16	2.0312.310.2	8	screw m 10 p.1.5 x 30
17	2.1655.407.0	2	pin 8x20
18	2.1530.022.0	4	oil seal 9.92x2.62
19	0.015.4431.2/10	2	tube mm 508
20	2.1539.237.0	1	oil seal 50.2x1.78
21	2.1539.219.0	1	oil seal
22	2.1549.652.0	1	spacer
23	2.1499.167.0	2	ring Ø 55
24	0.013.3935.3/70	1	shaft
25	2.2021.018.0	1	ball bearing 70x110x20
26	2.2041.018.0	2	ball bearing
27	0.015.0302.0/30	1	gear Z = 45 (1009 <-)
27	0.015.0302.0/40	1	gear Z = 45 (-> 1010)
28	2.2770.183.0	1	roller cage
29	2.1423.021.7	1	circlip 30x1.5
30	2.1410.018.7	1	circlip 45
31	2.1419.124.7	1	ring 153
32	0.013.4896.3/10	1	multi-plate clutch kpl.
33	2.1410.022.1	2	circlip 55
34	0.013.4443.0/10	1	slewing ring
35	2.4099.164.1	3	spring
36	2.1532.168.0	1	oil seal 71.12x2.62
37	0.013.4448.0/20	1	piston
38	2.1539.240.0	1	oil seal 139.37x2.62
39	0.015.0303.3/20	1	box
40	2.2030.012.0	1	ball bearing 55x90x18
41	0.015.0304.3	1	gear
42	2.1423.019.7	3	ring 28

GEARBOX INPUT SHAFT



9_J5432_00_0-B-001

Fig.	P/n	QTY	Name
43	0.013.4580.0	1	sleeve
44	2.2999.480.0	1	bearing
45	0.015.0305.0/20	1	gear Z = 36
46	0.013.4775.0	4	silent-block
47	2.1411.016.7	2	circlip 40 x 1.75
48	0.010.0526.4/10	1	accumulator P.T.O.
49	2.1514.035.0	1	oil seal
50	0.013.4898.0	1	disc
51	2.1560.010.0	1	gasket 14.2 x 20
53	2.3120.011.4	2	plug m 24 p.1.5
54	2.1560.019.0	2	copper gasket 24.3x30
55	2.1412.016.7	1	circlip 42

P.T.O. - CLUTCH TRANSMISSION SHAFT

Fig.	P/n	QTY	Name
------	-----	-----	------

Notes:

[SILVER³ 100 CONTINUO]

1	0.015.8740.0/20	1	power take-off shaft
2	0.016.1332.0/20	1	power take-off shaft
3	0.015.7710.0/20	1	sleeve
4	2.1411.007.1	1	circlip 21

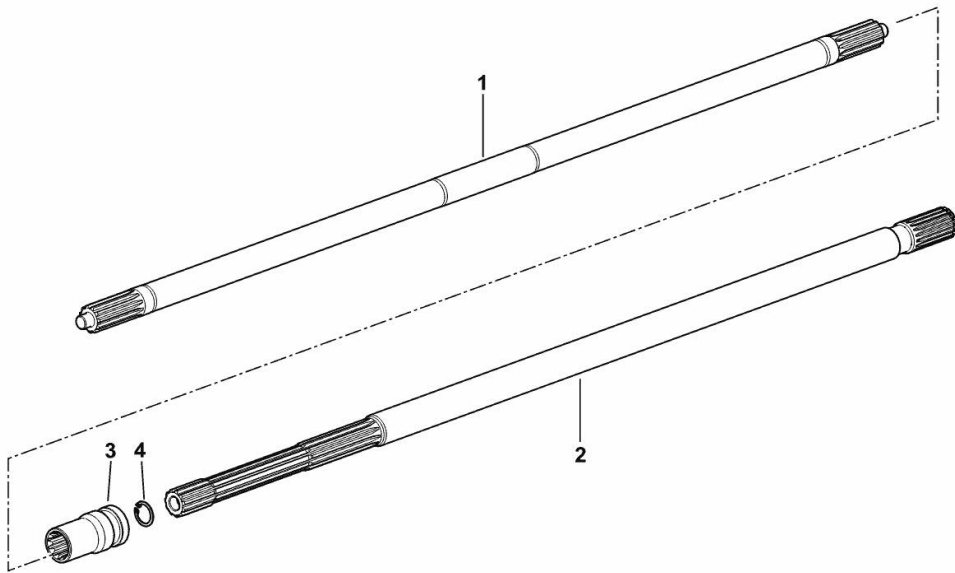

9_J5425_05_0-A-001

GEARBOX - REAR

9_J5431_05_0-A-001

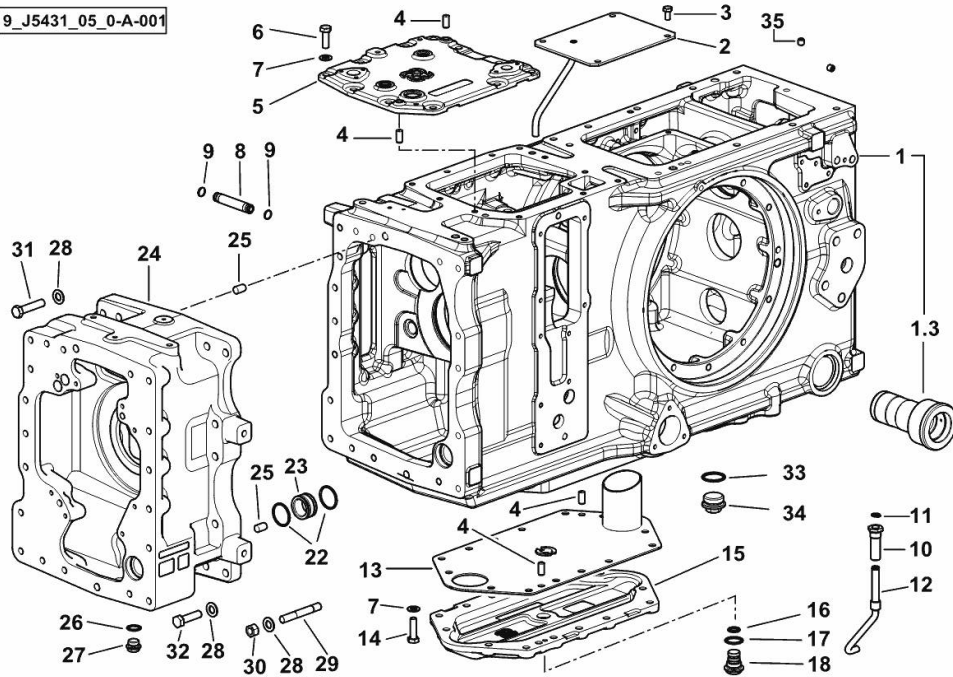

Notes:

[SILVER³ 100 CONTINUO]

Fig.	P/n	QTY	Name
1	0.016.0230.3/50	1	gear box
1.3	0.009.3197.0/20	2	bush
2	0.016.1363.2	1	gear box
3	2.0112.205.2	4	screw m 8 p.1.25 x 16
4	2.1655.550.0	4	pin
5	0.016.1347.0/40	1	cover
6	2.0112.311.2	11	screw m 10 p.1.5 x 30
7	2.1475.003.2	25	washer 10
8	0.015.3710.0/10	7	tube
9	2.1532.024.0	14	oil seal 10.77x2.62
10	0.015.4417.0/20	1	bushing
11	2.1410.002.2	1	circlip
12	0.015.4415.2/10	1	tube
13	0.016.1566.2/10	1	connecting plate
14	2.0112.313.2	14	screw m 10 p.1.5 x 35
15	0.016.1615.0/20	1	cover
16	2.1530.037.0	1	oil seal 15.08x2.62
17	2.1560.019.0	1	copper gasket 24.3x30
18	0.016.1641.0	1	plug
22	2.1532.091.0	2	ring 34.60 x 2.62
23	0.015.6319.0	1	sleeve
24	0.015.8366.0/20	1	body
25	2.1655.650.0	4	pin
26	2.1560.014.0	2	washer 18.2 x 24
27	2.3110.405.2	2	plug m 18 p.1.5 x 15
28	2.1475.004.7	18	washer 13 x 24
29	2.0432.269.2	6	old part number
30	2.1011.422.2	6	nut m 12 p.1.25
31	2.0112.417.2	4	screw m 12 p.1.75 x 45
32	2.0112.420.2	8	screw m 12 p.1.75x55
33	2.1560.056.0	1	gasket 33x39
34	2.3110.516.7	1	plug 1" gas
35	2.0512.303.7	4	screw m 10 p.1.5 x 10

GEARBOX INTERNAL FLANGES

Fig.	P/n	QTY	Name
------	-----	-----	------

Notes:
[SILVER³ 100 CONTINUO]

1	0.015.7571.3/30	1	flange
2	2.0112.237.2	5	screw m 8 p.1.25x140
3	2.1475.002.7	23	washer 8.4
4	2.0112.231.2	6	screw m 8 p.1.25 x 110
5	0.014.9712.3/30	1	screw
5.2	2.1655.455.0	2	pin 8x90
6	2.1530.018.0	2	oil seal 9.19 x 2.62
7	2.0399.323.2	1	screw m 8 p.1
8	0.015.8405.0	1	flange
9	2.0112.209.2	4	screw m 8 p 1.25 x 25
11	0.015.8271.0/10	1	cover
12	2.0112.215.2	6	screw m 8 p.1.25 x 40
13	2.0112.221.2	2	screw m 8 p.1.25 x 60
18	2.1655.508.0	2	pin 10x24
21	0.014.9761.2/10	2	tube
22	2.1530.022.0	4	oil seal 9.92x2.62
27	2.2999.469.0	1	special bearing 30x55x13

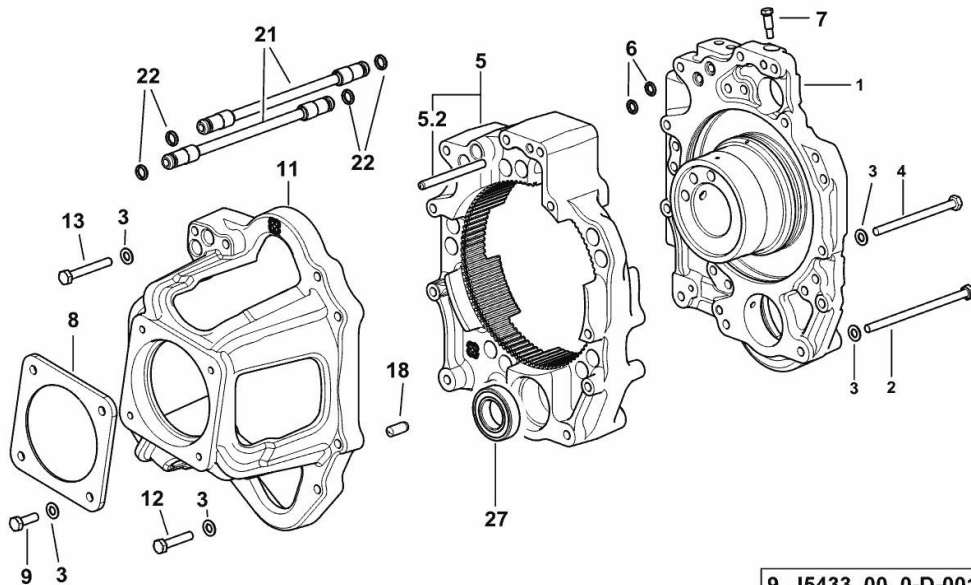

9_J5433_00_0-D-001

GEARBOX - WEARING PARTS

Fig.	P/n	QTY	Name
------	-----	-----	------

Notes:
[SILVER³ 100 CONTINUO]

1	2.1532.075.0	1	ring
2	0.017.6425.0	1	flange
3	2.1470.002.2	3	lock washer 6
4	2.0112.005.2	3	screw m 6 p.1 x 16

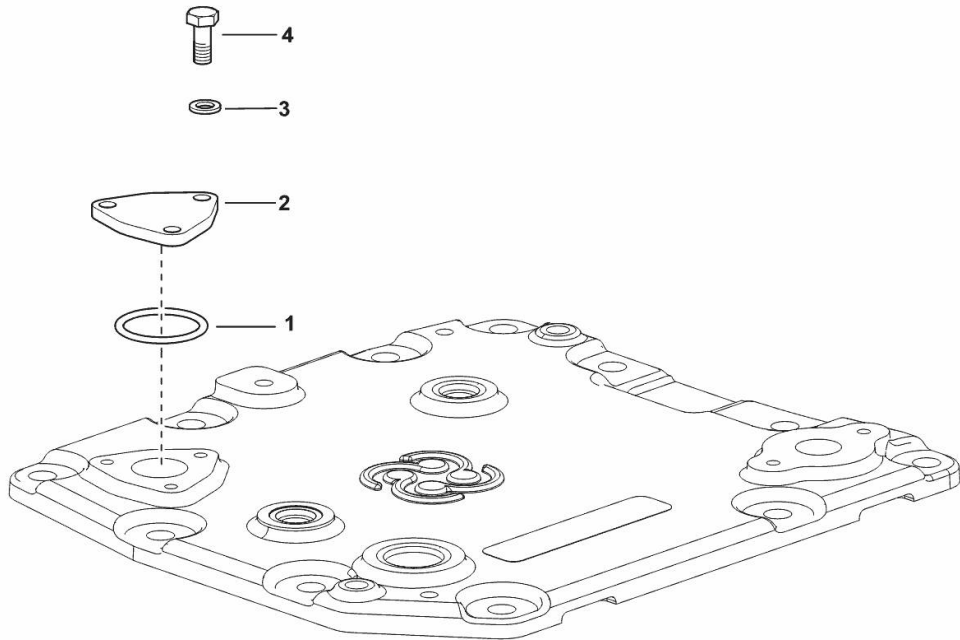

9_R8982_52_0-A-001

PLUGS

Fig.	P/n	QTY	Name
------	-----	-----	------

Notes:[SILVER³ 100 CONTINUO] 1001 <-

1	2.3121.008.2	1	plug
2	2.3121.004.2	1	plug m 14 p.1.5

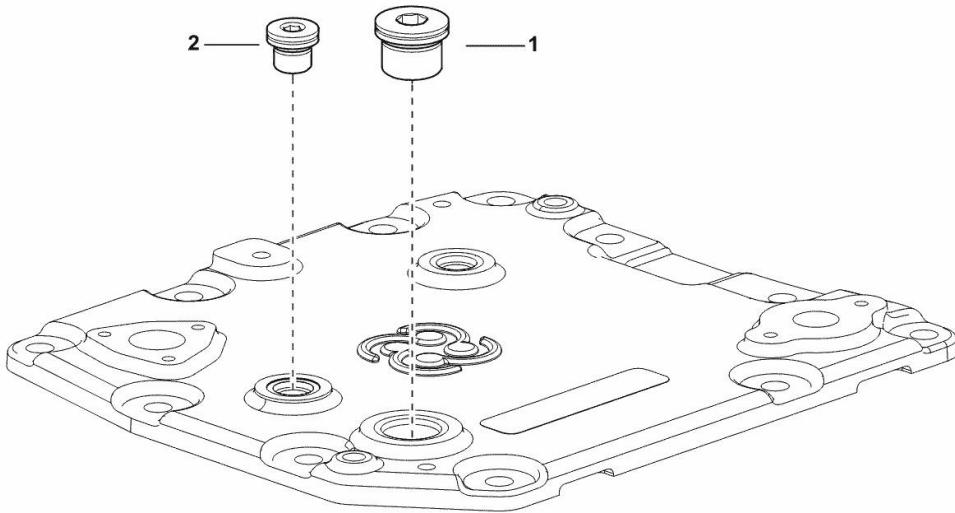

9_R8982_19_0-A-001

REAR GEARBOX COVER PLUG

Fig.	P/n	QTY	Name
------	-----	-----	------

Notes:[SILVER³ 100 CONTINUO]

1	2.3121.004.2	1	plug m 14 p.1.5
---	--------------	---	-----------------

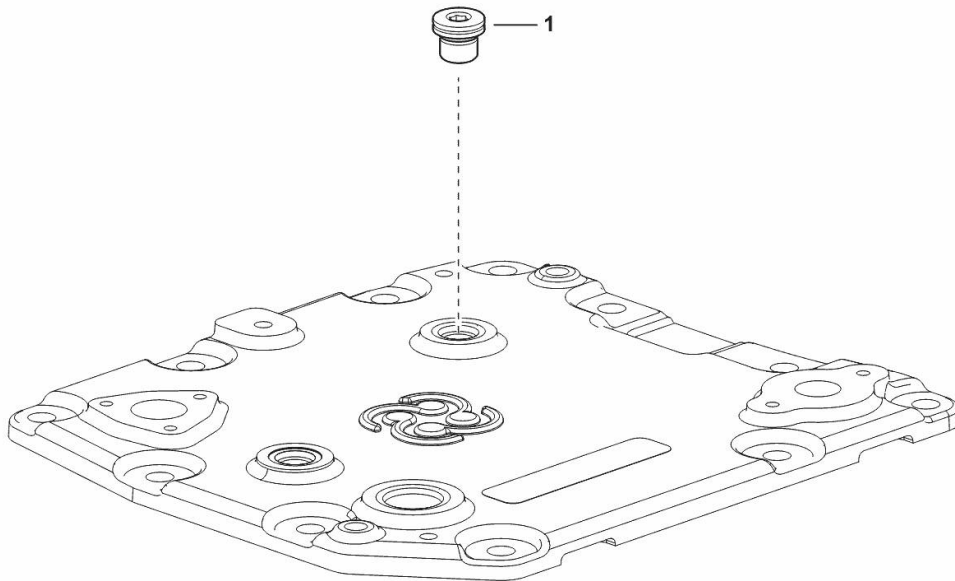

9_R8959_84_0-A-001

CONTROL FOR HEAVY DUTY RANGE REDUCTION GEAR

Fig.	P/n	QTY	Name
------	-----	-----	------

Notes:

[SILVER³ 100 CONTINUO]

15	2.1532.112.0	2	oil seal 44.2x2.62
26	0.016.0214.0/10	1	fork
27	2.0399.019.1	1	screw m 8 p.1 x 16
28	0.016.0604.0	1	rod
29	2.2999.156.0	1	ball Ø 10
30	2.4019.622.1	1	spring 6.3 x 9.5 x 1.6 x 22.4
31	2.1560.008.0	1	gasket 12.2 x 18
32	2.3199.164.2/20	1	plug m 12 p.1.5
35	0.016.0537.0	1	lever
36	2.2725.030.0	2	roller cage 22 x 28 x 16
37	0.016.0539.0/10	1	support
38	2.1519.075.0	1	oil seal 22 x 35 x 6
39	0.016.0583.3	1	lever
40	2.0399.050.2	1	screw m 10 p.1 x 30
41	2.1011.406.2	1	nut m 10 p.1
42	2.1475.102.2	3	washer 8.4 x 16
43	2.0112.209.2	3	screw m 8 p 1.25 x 25

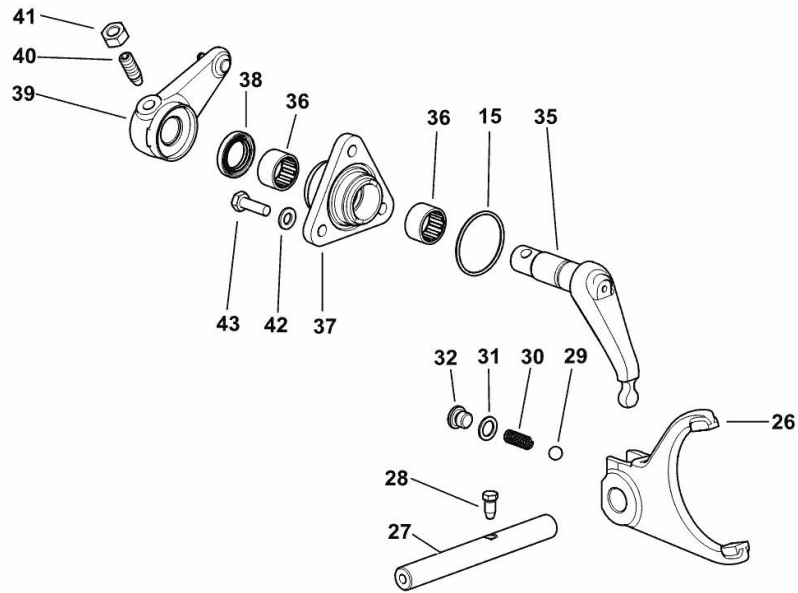

9_J5434_05_0-B-001

RANGE REDUCTION GEAR - HEAVY DUTY

Fig.	P/n	QTY	Name
------	-----	-----	------

Notes:

[SILVER³ 100 CONTINUO]

1	0.016.0156.0	1	bushing
2	2.2770.245.0	2	roller cage
3	2.1549.413.0	1	spacer 47x52.8x4
4	0.016.0155.0	1	gear Z = 36 (1058 <-)
4	0.016.0155.0/10	1	gear Z = 36 (-> 1059)
5	0.014.3116.0/10	1	sleeve
6	0.016.0154.0	1	hub
7	2.1410.014.1	1	circlip 35
8	0.016.0168.0	1	ring
9	2.1411.042.7	2	circlip 110
10	2.2040.016.0	2	ball bearing
11	2.1423.030.7	1	circlip 40
12	2.1549.648.0	1	spacer 32x40x7.5
13	2.2999.452.0	1	roller cage
14	0.016.0165.0/10	1	gear Z = 24
15	2.1532.112.0	2	oil seal 44.2x2.62
16	0.016.0181.0/10	1	sleeve
17	2.0399.333.0/10	1	screw
18	0.016.0147.0/10	1	bushing
19	2.2999.504.0	2	roller cage
20	0.016.0145.0	1	gear z = 37 z = 28
21	0.016.0148.0/10	1	pin
22	2.1411.030.7	1	circlip 75x2.5
23	2.1532.024.0	1	oil seal 10.77x2.62
24	2.3249.231.2/10	1	pipe fitting m 14 p.1.5
25	2.1560.010.0	1	gasket 14.2 x 20

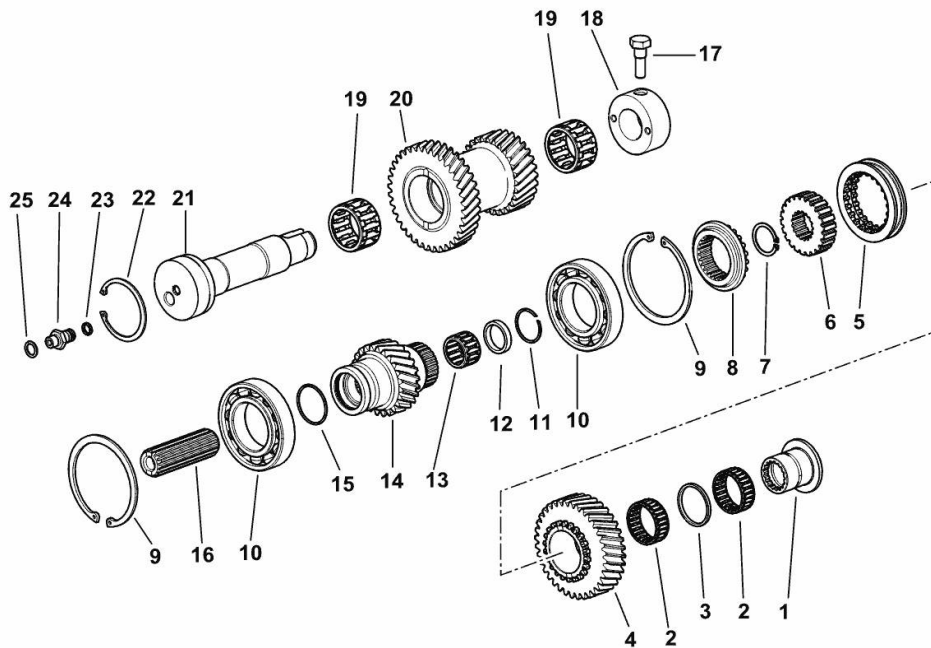

9_J5434_05_0-A-001

BEVEL WHEEL GEAR

Fig.	P/n	QTY	Name
------	-----	-----	------

Notes:[SILVER³ 100 CONTINUO]

1	0.016.0127.3/10	1	bevel drive z= 11 z= 62
---	-----------------	---	-------------------------

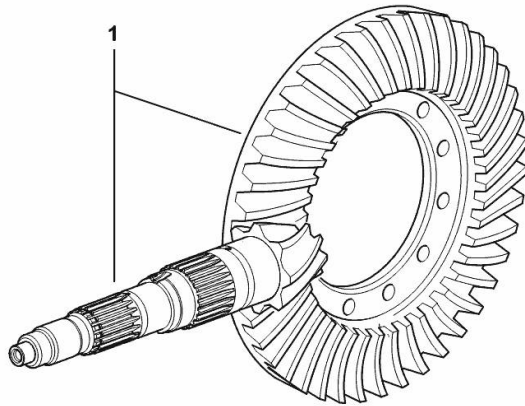

9_J5435_05_0-A-001

Thank you so much for reading.
Please click the “Buy Now!”
button below to download the
complete manual.



After you pay.

You can download the most
perfect and complete manual in
the world immediately.

Our support email:

ebooklibonline@outlook.com