

Section: ENGINE
CRANKCASE

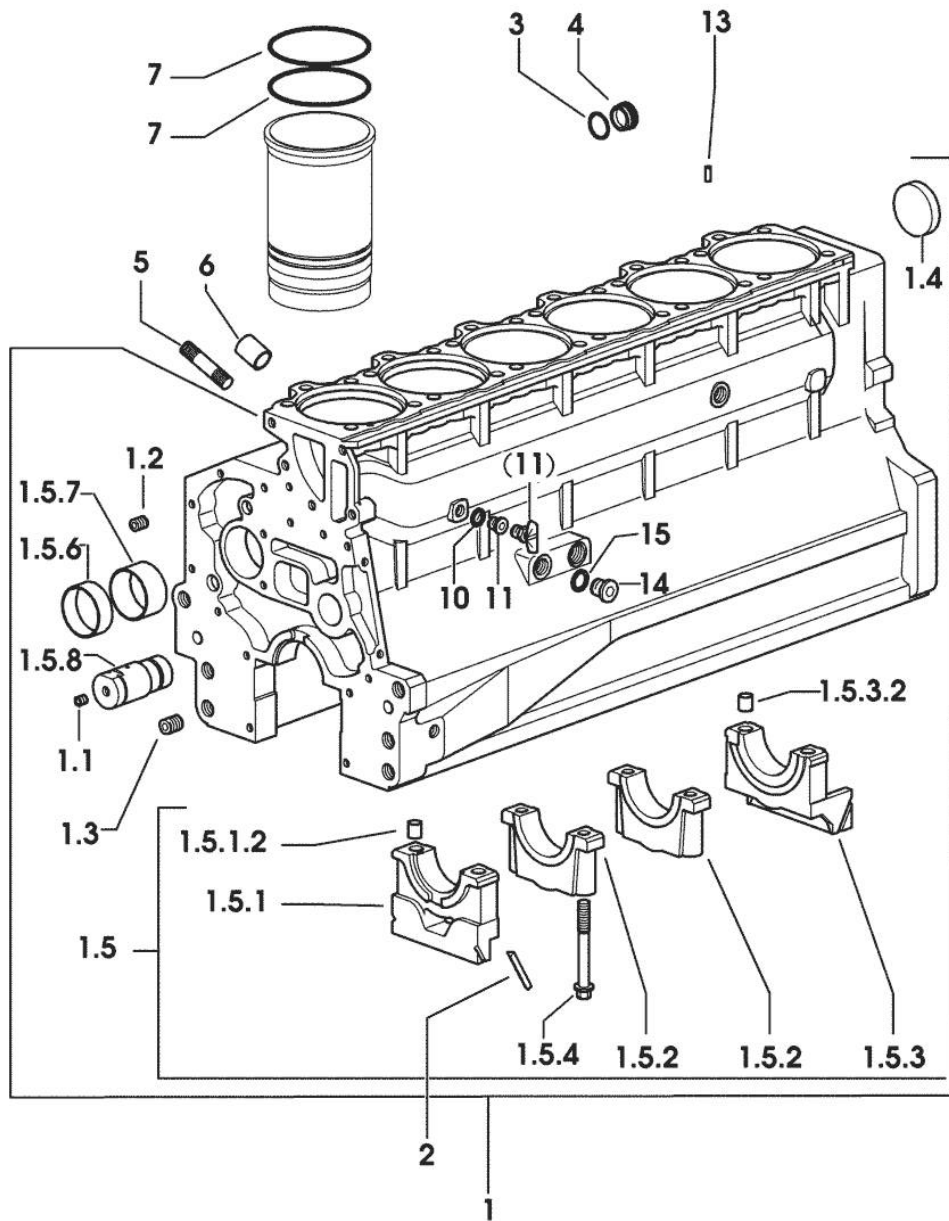

Fig.	P/n	QTY	Name
------	-----	-----	------

Notes:
 [SX-1200]

1	0.007.1102.6/20	1	crankcase
1.1	2.3130.001.1	14	plug 1/8" gas
1.2	2.3130.002.1	2	plug 1/4" gas
1.3	2.3130.003.1	8	plug 3/8" gas
1.4	2.3179.012.0	1	plug 60
1.5	0.000.0000.1		cannot be supplied
1.5.1	0.065.1112.7	1	support
1.5.1.2	2.1699.165.0	1	bush 12.3x15x16
1.5.2	0.065.1114.0/10	5	support
1.5.3	0.007.0848.3/10	1	support
1.5.3.2	2.1699.165.0	1	bush 12.3x15x16
1.5.4	0.065.1117.0	14	screw m 12 x 100
1.5.6	0.065.1140.0	6	special bushing 59X55X20
1.5.7	0.065.1141.0	1	special bushing 59X55X30
1.5.8	0.066.1151.0	1	pin
2	0.066.1152.0/10	4	gasket
3	2.1532.072.0	1	oil seal 26.70x1.78
4	2.3199.405.2	1	plug m 28 p.1.5
5	2.0432.003.7	18	stud bolt m 8 p.1.25 / p.1 x 20
6	2.1559.188.2	6	bush 11.4 x 14 x16
7	2.1539.193.0	12	special oil seal 107.62x2.62
10	2.1560.010.0	1	gasket 14.2 x 20
11	2.3199.292.0	1	plug 1/4" gas
13	2.1549.154.2	6	bush 4.8x5.8x16
14	2.3120.101.0	1	plug m 18 p.1.5
15	2.1560.014.0	1	washer 18.2 x 24

9_33711_00_0_0

PISTON COOL.NOZZLE

Fig.	P/n	QTY	Name
------	-----	-----	------

Notes:
[SX-1200]

14	0.086.1550.2	6	sprayer nozzle
15	2.1099.108.2	6	special nut m 10 p.1
16	2.1560.006.0	12	gasket 10.2 x 16
17	0.065.1160.3/20	6	valve

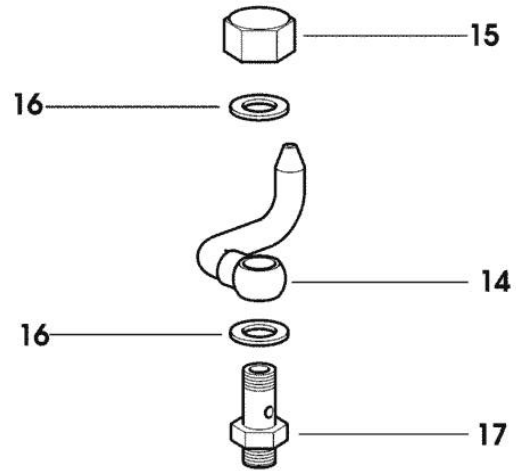

9_33715_02_0_0

Section: ENGINE
CONNECTING FLANGE

Fig.	P/n	QTY	Name
------	-----	-----	------

Notes:
[SX-1200]

1	0.011.2000.0/20	1	flange
6	2.0439.250.7	1	stud bolt m 12 / m 10 x 30
7	0.011.9294.0/10	1	bush
9	2.0112.513.2	11	screw m 14 p.2 x 35
10	2.0432.328.7	4	stud bolt m 14 p.2-1.5x130
12	2.0112.534.2	2	screw m 14 p.2x125
13	2.1651.911.0	2	cylindrical plug
14	2.1011.108.2	4	nut m 14 p.2
15	2.0432.257.7	1	stud bolt m 12 p.1.75 - 1.25 x 30
16	2.0312.520.2	2	screw m 14 p.2x70

9_38411_01_0_0

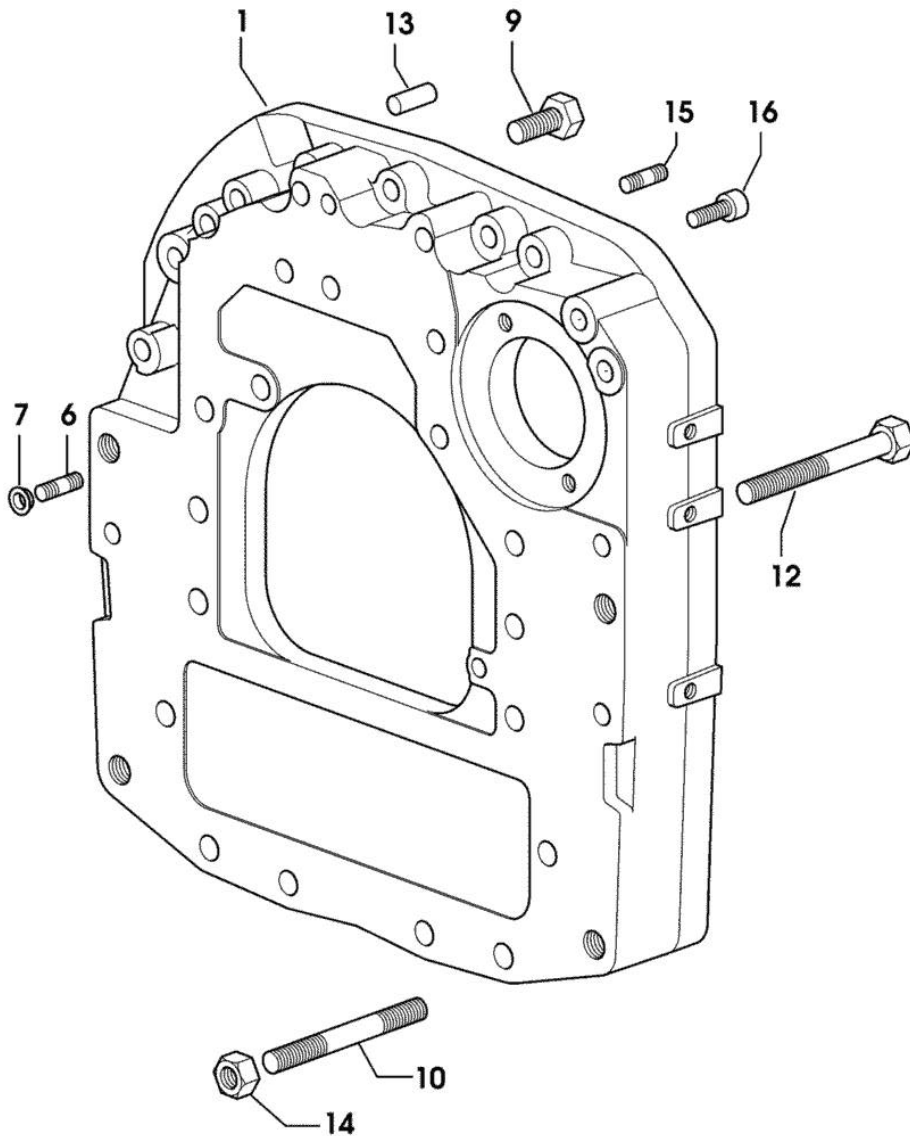
Fig.	P/n	QTY	Name
------	-----	-----	------

Notes:
 [SX-1200]

1	0.007.1262.3/50	1	guard
2	0.007.1271.0/10	1	small column m 8 p.1.25 / L = mm 60
3	0.007.1272.0/10	2	small column m 8 p.1.25 / L = mm 50
5	2.1310.004.2	3	flat washer 8.4x17
7	2.0112.203.2	3	screw m 8 p.1.25 x 12

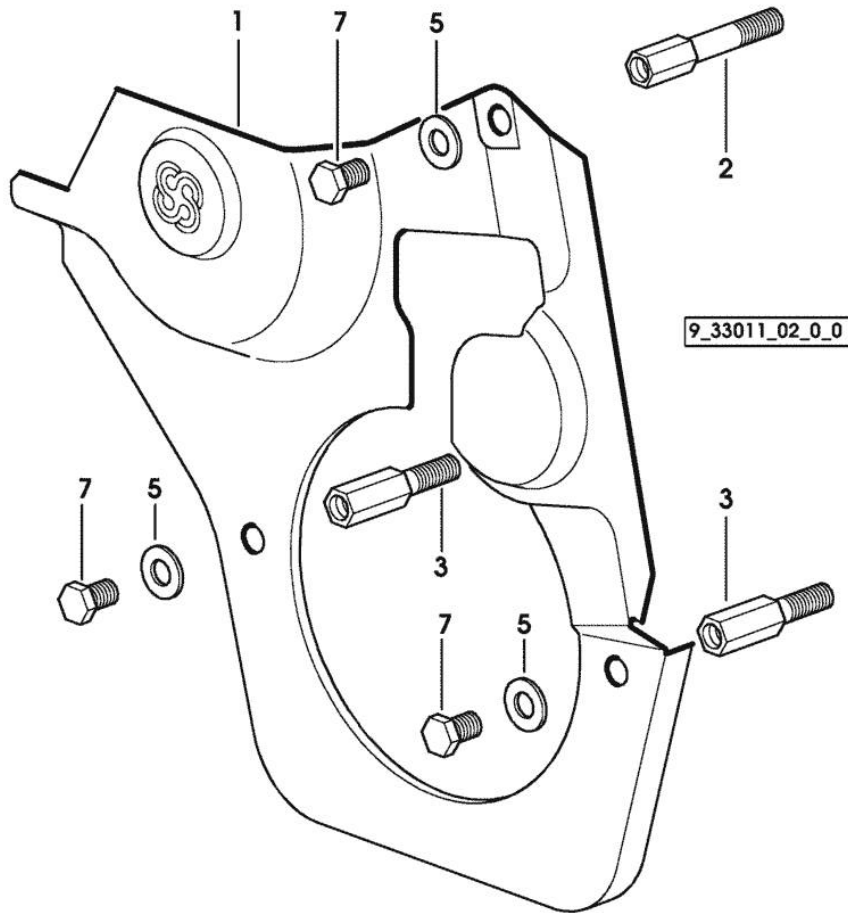

9_33611_01_0_0

SX-1200

Ref: 01.00.19

Section: ENGINE
TIMING CASE

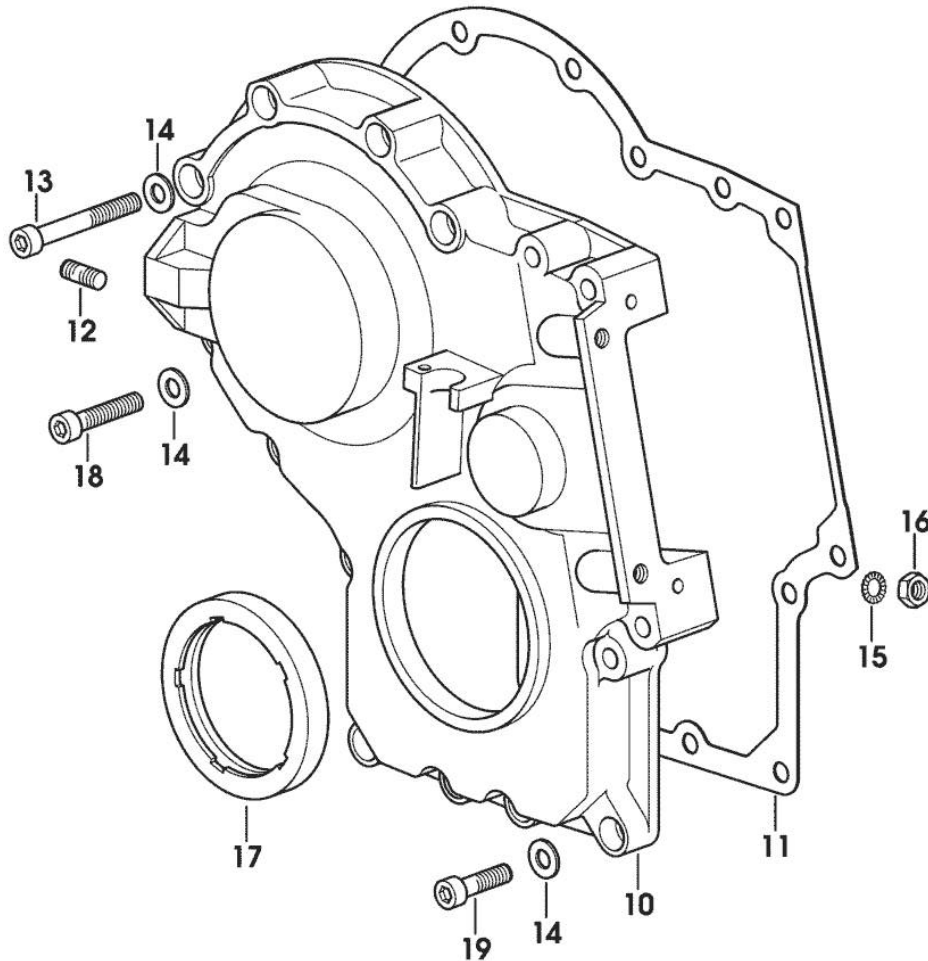

Fig.	P/n	QTY	Name
Notes: [SX-1200]			
10	0.013.4981.0	1	guard -> 1004 X SX-1200 -> 1028 X SX-1350 -> 1017 X SX-1500
10	0.065.1132.0/50	1	guard 1003 <- X SX-1200 1027 <- X SX-1350 1016 <- X SX-1500
11	0.065.1150.0/30	1	gasket
12	2.0432.003.7	2	stud bolt m 8 p.1.25 / p.1 x 20
13	2.0312.219.2	4	screw m 8 p.1.25x65
14	2.1480.014.1	15	washer 8
15	2.1470.004.2	4	lock washer 8
16	2.1011.405.2	2	nut m 8 p.1
17	2.1529.141.0	1	special oil seal
18	2.0312.214.2	3	screw m 8 p.1.25 x 40
19	2.0312.208.2	8	screw m 8 p.1.25 x 25

Section: ENGINE
CASING COVER

Fig.	P/n	QTY	Name
------	-----	-----	------

Notes:
 [SX-1200]

30	0.065.1152.0	1	gasket
31	0.065.1151.0	1	cover
32	2.0112.205.2	2	screw m 8 p.1.25 x 16
34	2.0432.005.7	2	stud bolt m 8 p.1.5 / p.1 x 25

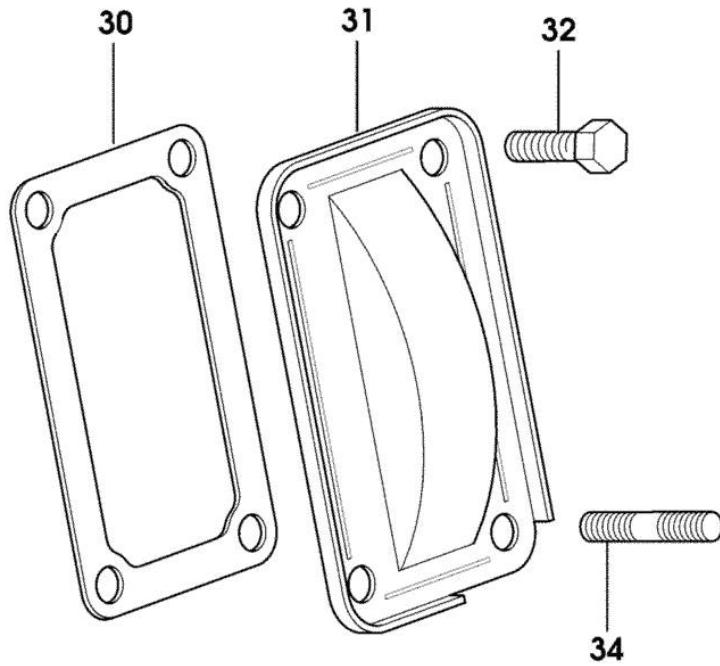

9_33011_04_0_0

Section: ENGINE
CRANKSHAFT

Fig.	P/n	QTY	Name
------	-----	-----	------

Notes:
 [SX-1200]

2	2.1651.915.0	1	pin 12x35
3	0.065.1215.0	7	main half bushing STANDARD
3	0.065.1215.7		main half bushing - mm 0.25
3	0.065.1215.8		main half bushing - mm 0.50
4	0.065.1216.0	7	main half bushing
4	0.065.1216.7		main half bushing - mm 0.25
4	0.065.1216.8		main half bushing - mm 0.50
5	0.065.1218.0	4	shim STANDARD
5	0.065.1218.7		shim + mm 0.10
5	0.065.1218.8		shim + mm 0.15
6	2.1599.524.7	1	washer 21x60x12
7	2.1720.006.0	1	key 4x6.5
9	0.065.1254.0/20	1	gasket
10	0.007.0851.0/10	1	cover
11	2.1529.073.0	1	special oil seal 110x130x13
12	2.1475.002.2	9	conical washer 8
13	2.0112.207.2	7	screw m 8 p 1.25 x 20
14	2.3130.001.1	6	plug 1/8" gas
15	2.1589.137.0	2	shoulder ring 71x110x1
16	2.0432.003.7	2	stud bolt m 8 p.1.25 / p.1 x 20
17	2.1011.105.2	2	nut m 8 p.1.25
20	0.009.3704.3	1	antivibration pulley
21	0.010.4320.3/20	1	crankshaft
21.2	0.007.0855.0/10	1	gear
22	0.011.2206.0/10	1	hub
23	2.0399.144.7/10	1	screw m 20 p.1.5x51

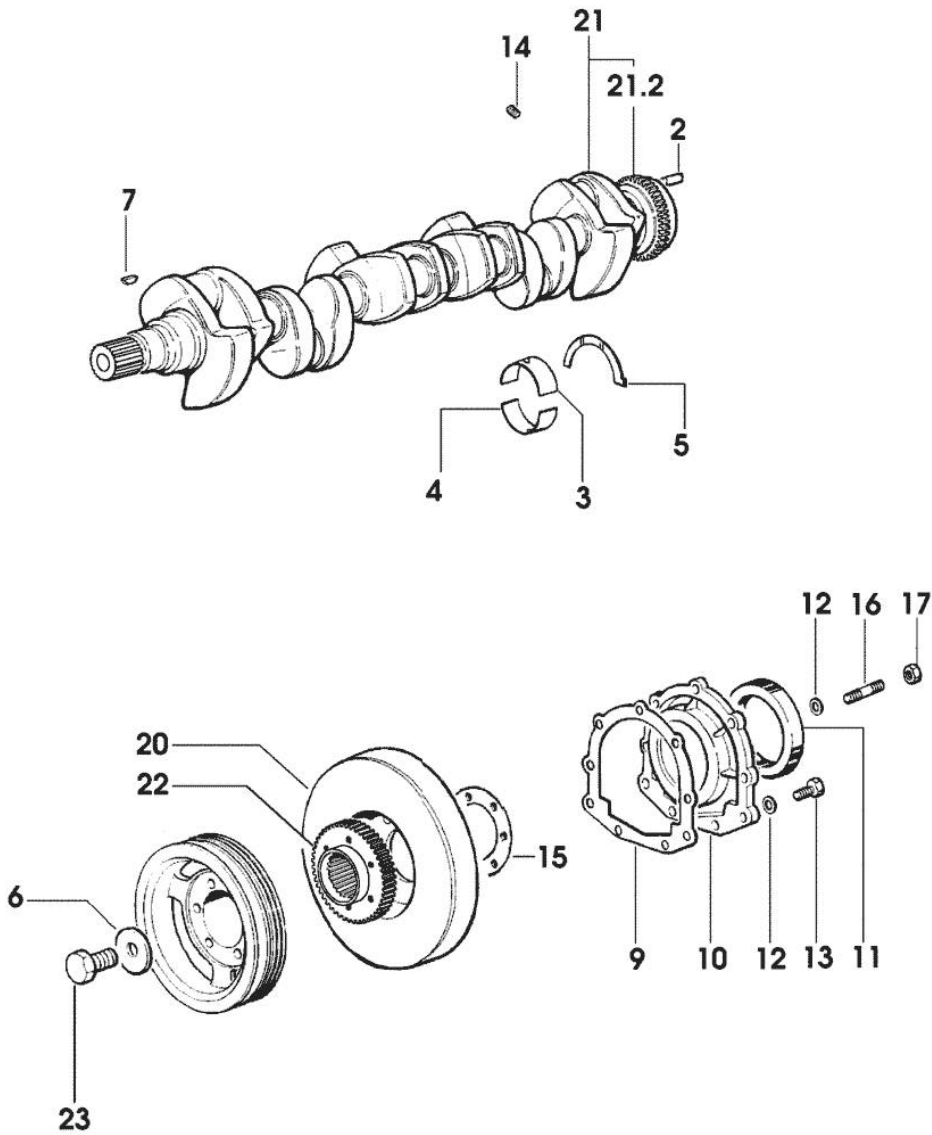

9_37912_00_0_0

Section: ENGINE

CRANKSHAFT PULLEY

Fig.	P/n	QTY	Name
------	-----	-----	------

Notes:
[SX-1200]

1	0.010.5449.0/10	1	pulley
2	2.0112.322.2	6	screw m 10 p.1.5x65
3	2.1470.006.2	6	lock washer 10
4	2.1589.137.0	2	shoulder ring 71x110x1

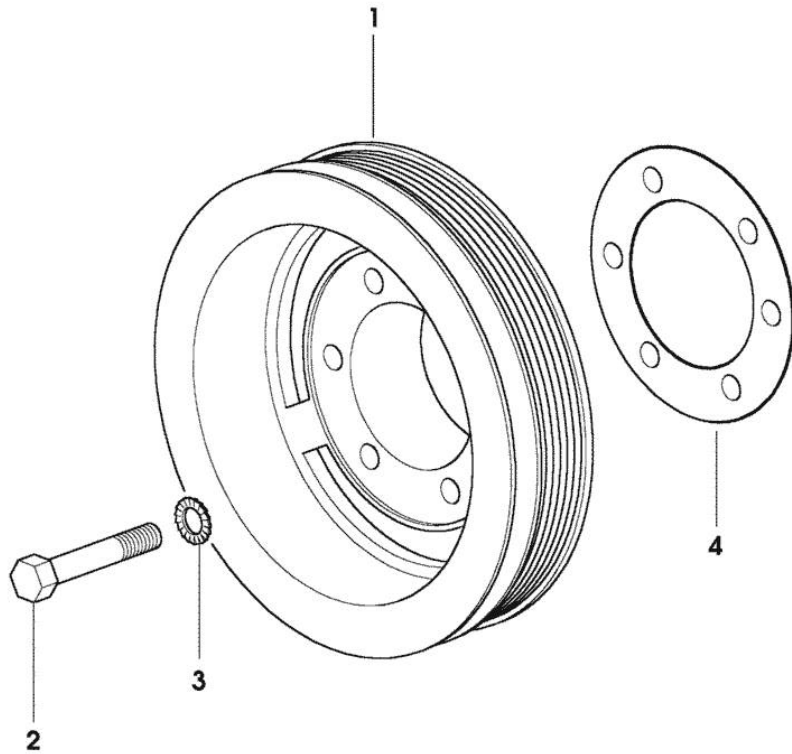

9_38012_01_0_0

CYLINDER - PISTON - CONNECTING ROD

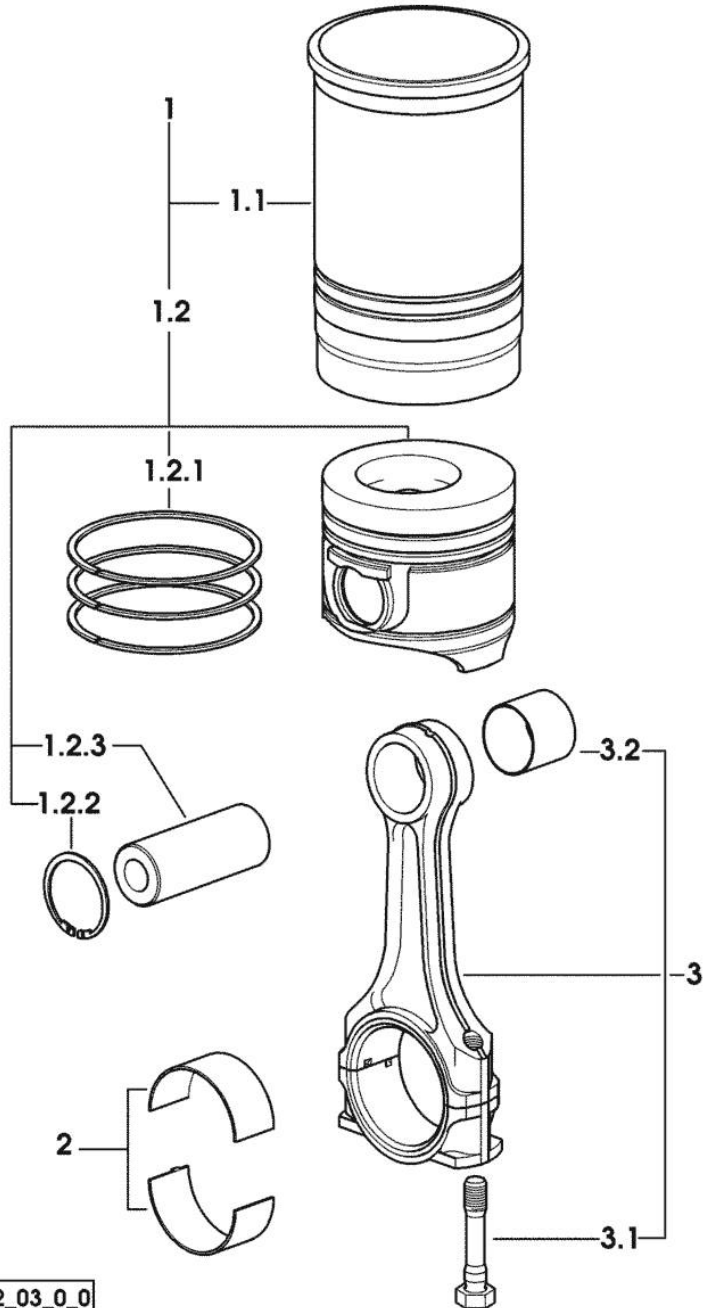

Fig.	P/n	QTY	Name
------	-----	-----	------

Notes:
[SX-1200]

1	0.386.0065.A	6	cyl. piston assembly "A" - CLASS A
1	0.386.0065.B	6	cyl. piston assembly "B" - CLASS B
1.1	0.011.0183.0/20	1	engine cylinder (...) <- X SX-1200
1.1	0.A12.2675.0	1	engine cylinder "A" -> (...) X SX-1200 - CLASS A
1.1	0.B12.2675.0	1	engine cylinder "B" -> (...) X SX-1200 - CLASS B
1.2	0.379.0060.6	1	complete piston (...) <- X SX-1200
1.2	0.379.0060.A	1	complete piston "A" -> (...) X SX-1200 - CLASS A
1.2	0.379.0060.B	1	complete piston "B" -> (...) X SX-1200 - CLASS B
1.2.1	0.086.0052.6/10	1	piston ring set
1.2.2	2.1411.014.1	2	circlip 35
1.2.3	0.078.1236.0	1	piston pin Ø 18 / Ø 35 / L = mm 86
2	0.065.1225.0	12	con.rod half bushing STANDARD - A = 28.75 -> 29.00
2	0.065.1225.7	12	con.rod half bushing - mm 0.25
2	0.065.1225.8	12	con.rod half bushing - mm 0.50
3	0.078.1220.3/30	6	engine connecting rod
3.1	2.0399.213.0	2	screw m 12 p.1.25x61.5
3.2	2.1559.114.0/10	1	special bushing

Section: ENGINE

ENGINE FLYWHEEL

Fig.	P/n	QTY	Name
------	-----	-----	------

Notes:
[SX-1200]

1	0.007.0655.3/20	1	flywheel
1.2	0.065.1242.0	1	crown wheel Z = 123
2	2.0119.174.0/10	6	screw m 12 p.1.25x45

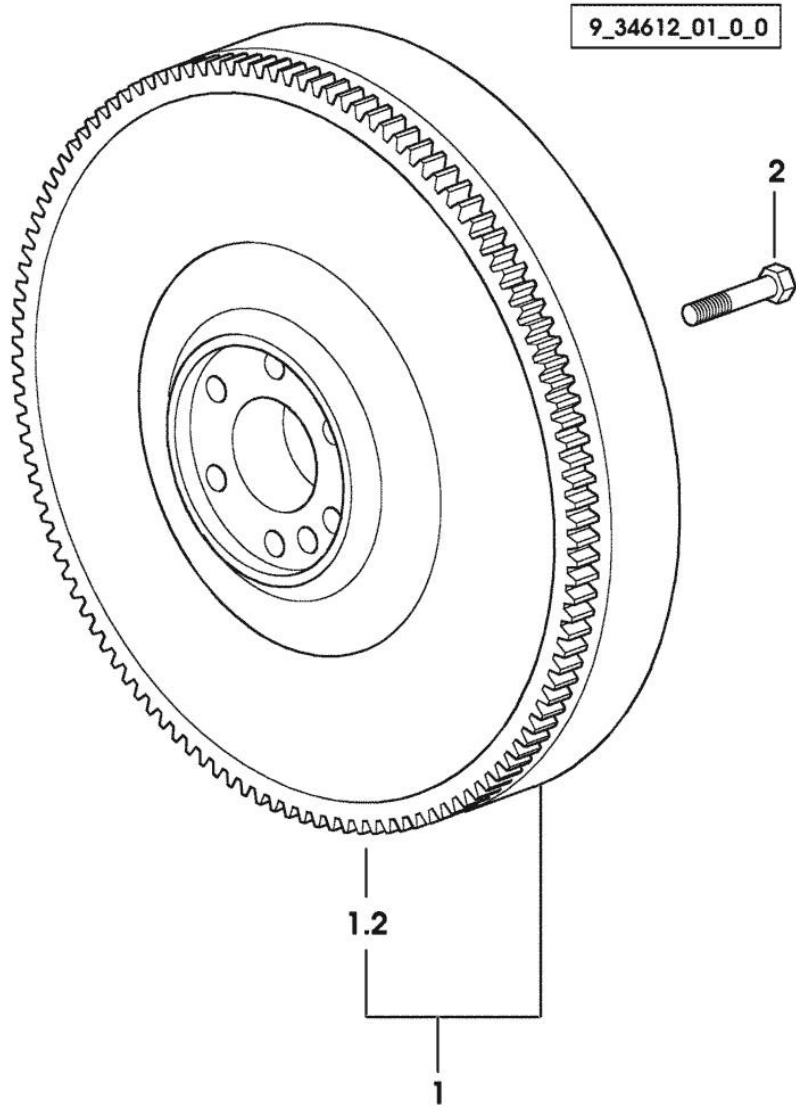

Section: ENGINE

CAMSHAFT

Fig.	P/n	QTY	Name
------	-----	-----	------

Notes:
[SX-1200]

1	0.065.1331.2	12	rod
2	2.1569.114.0/10	24	gasket 14x18.5x8
3	0.065.1332.0	12	sleeve
4	2.4019.300.1/10	12	spring 18.5x52x2
5	2.1599.437.0	12	shoulder ring
6	0.065.1330.0	12	tappets
7	0.065.1354.0/20	1	gear z=58
8	2.0132.207.2	4	screw m 10 p.1 x 25
9	0.010.4968.3/10	1	camshaft
9.2	0.065.1324.0/10	1	gear Z = 32
10	0.065.1350.0	1	small disc
11	2.1410.016.1	1	circlip 40
12	0.065.1352.0	1	shim
13	0.065.1351.0	2	shoulder ring
14	0.007.1188.0/30	1	gear Z = 29
16	2.0312.205.2	2	screw
17	2.1480.014.1	2	washer 8
18	0.065.1353.0	1	small plate
19	0.007.1177.3/20		gear z = 57 - WITH RED IDENTIFICATION STAMP
19.2	2.1559.185.0/10	1	bushing
20	0.007.1178.3/20		gear z = 57 - WITH YELLOW IDENTIFICATION STAMP
20.2	2.1559.185.0/10	1	bushing
21	0.007.1179.3/20	1	gear z = 57 - WITH GREEN IDENTIFICATION STAMP
21.2	2.1559.185.0/10	1	bushing
22	2.1559.398.0	1	bushing 10.5x13x12 -> 1001 X SX-1200 -> 1015 X SX-1350

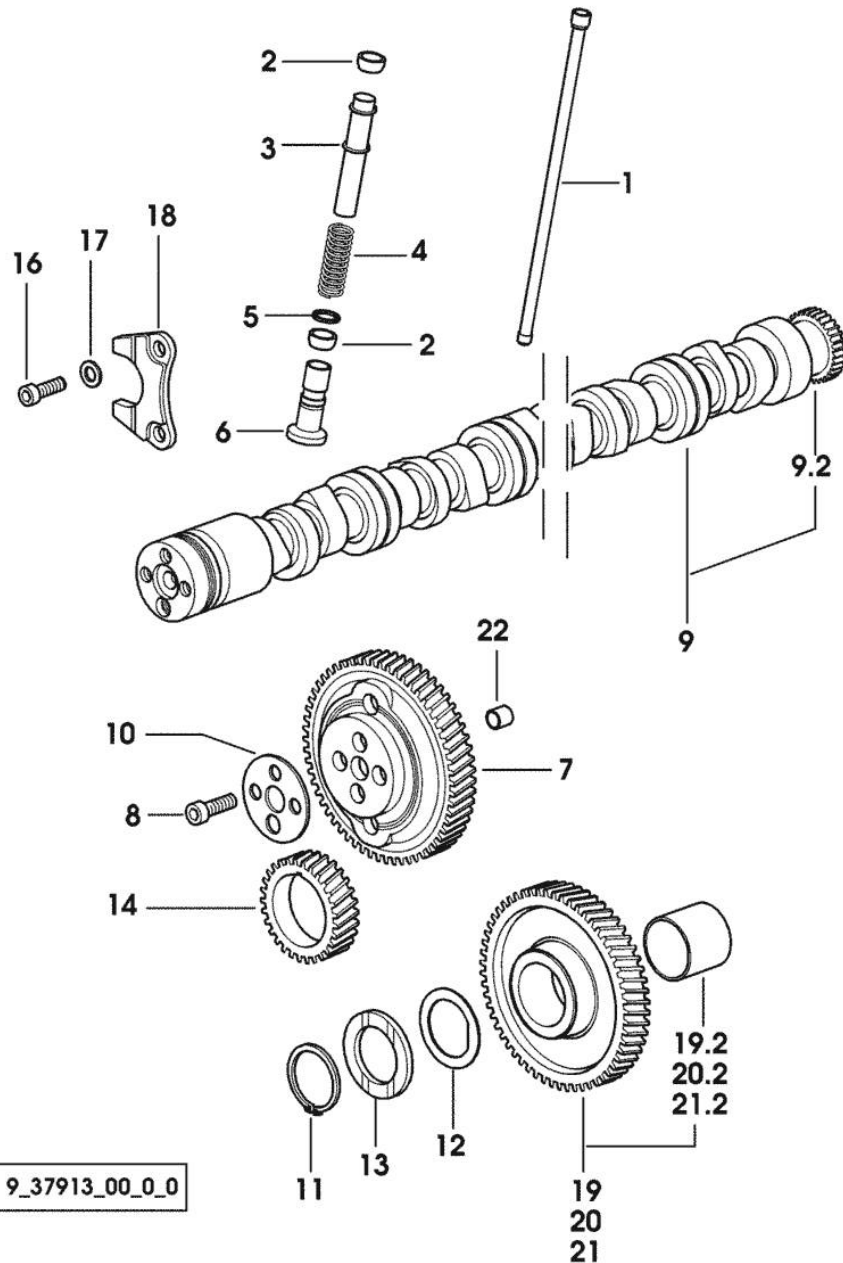

Section: ENGINE
CYLINDER HEAD

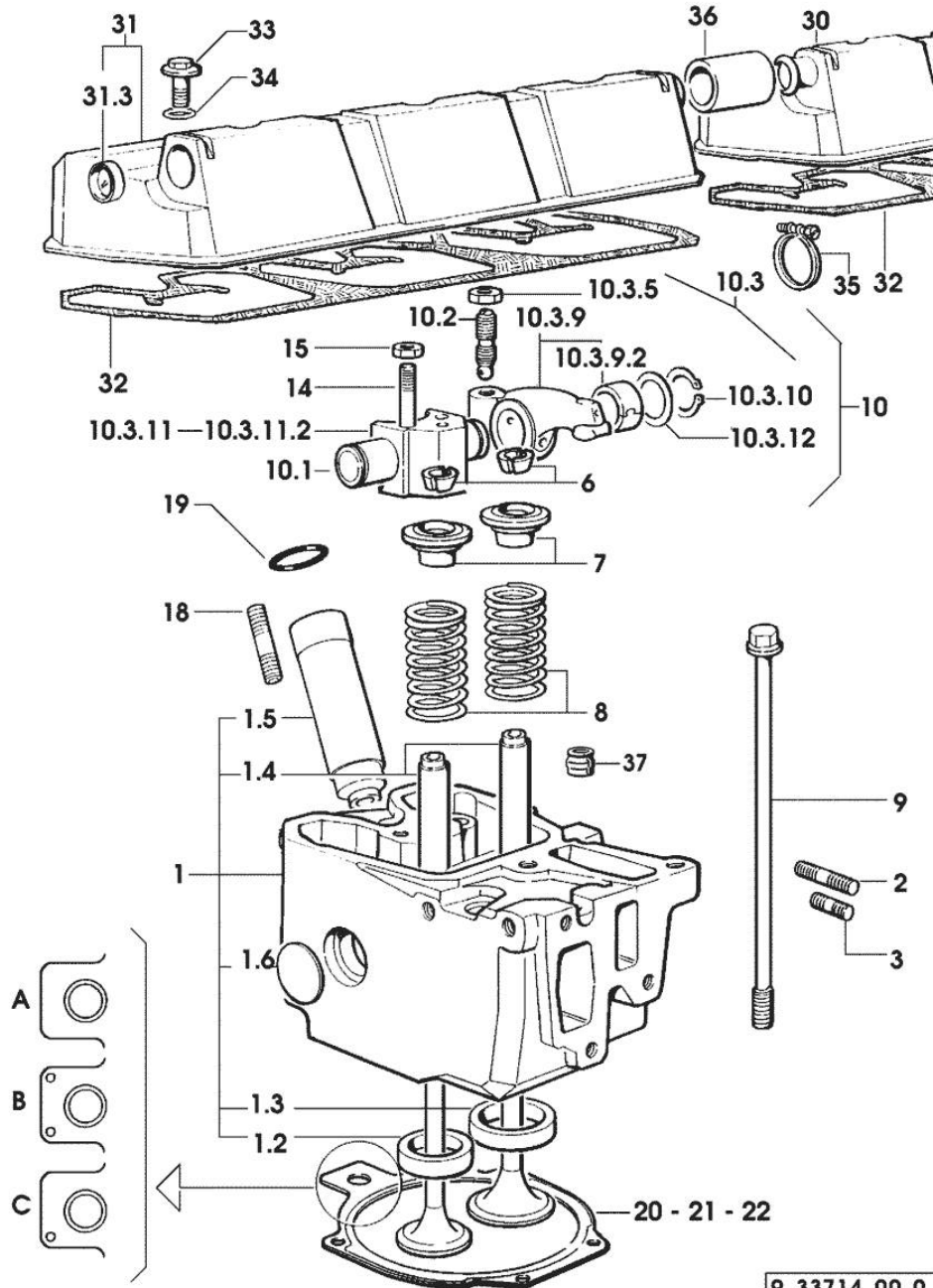

Fig.	P/n	QTY	Name
------	-----	-----	------

Notes:
[SX-1200]

1	0.012.2693.3/10	6	engine head
1.2	0.078.1426.0	1	valve seat
1.3	0.066.1427.0	1	valve seat
1.4	0.007.1779.0/10	2	valve guide
1.5	0.010.6041.0	1	bush
1.6	2.3170.012.1	2	expansion plug 30
2	2.0432.011.7	6	stud bolt m 8 p.1.25 / p.1 x 40
3	2.0432.005.7	6	stud bolt m 8 p.1.5 / p.1 x 25
6	0.074.1423.0	24	conical valve cotter
7	0.066.1425.0	12	cup
8	2.4019.287.0	12	spring
9	0.012.2673.0	24	screw m 14 p.2x141 -> 1016 X SX-1200
9	0.066.1443.0/10	24	screw 1015 <- X SX-1200
10	0.000.0000.1		cannot be supplied
10.1	0.066.1431.0	1	pin
10.2	0.021.1434.0	2	screw
10.3	0.000.0000.1		cannot be supplied
10.3.5	2.1011.405.2	2	nut m 8 p.1
10.3.9	0.066.1432.3	2	rocker arm
10.3.9.2	2.1559.021.0/40	1	bushing 15x19x22
10.3.10	2.1410.055.7	2	circlip 19
10.3.11	0.000.0000.1		cannot be supplied
10.3.11.2	0.066.1430.0/10	1	support
10.3.12	2.1599.432.0	2	shoulder ring
14	2.0432.163.7	6	stud bolt m 10 p.1.5 / p.1.25 x 45
15	2.1011.421.2	12	nut m 10 p.1.25
18	2.0432.161.7	6	stud bolt m 10 p.1.5 / p.1.25 x 40
19	2.1530.051.0	6	oil seal 20.22x3.53
20	0.078.1451.0/40		head gasket -A-
21	0.078.1452.0/30		head gasket -B-
22	0.078.1453.0/40		head gasket -C-
30	0.078.1450.3	1	cover (...) <- X SX-1200
30	0.078.1450.3/10	1	cover -> (...) X SX-1200
31	0.078.1440.3	1	cover (...) <- X SX-1200
31	0.078.1440.3/10	1	cover -> (...) X SX-1200

9_33714_00_0_0

Section: ENGINE
CYLINDER HEAD

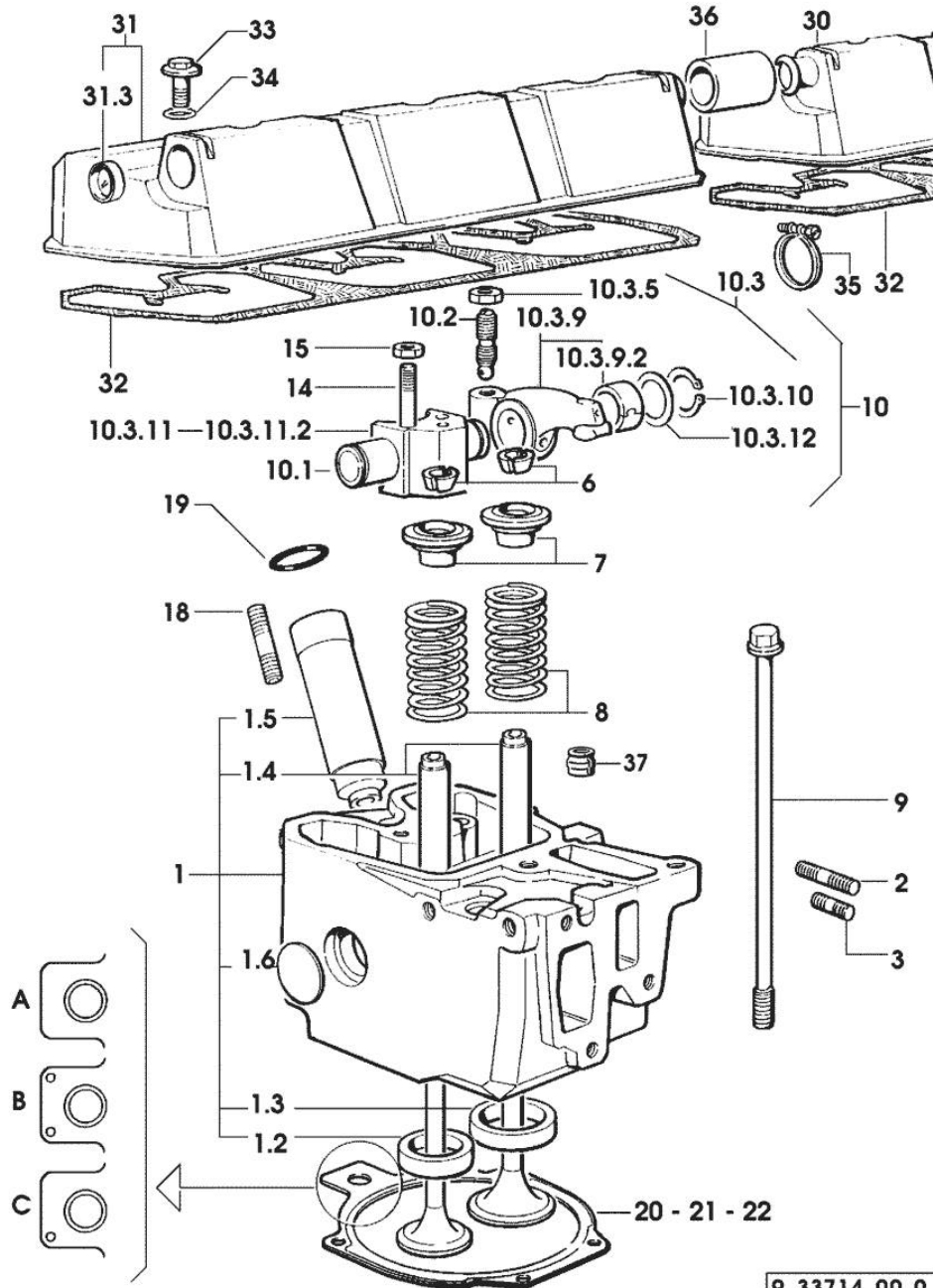

Fig.	P/n	QTY	Name
31.3	2.3171.008.4	1	plug 20
32	0.009.3877.0/10	2	tappet gasket
33	2.0399.288.2/10	6	screw m 8x36x46
34	2.1532.035.0	6	oil seal 14x1.78
34	2.1539.151.0	6	special oil seal 9.19 x 2.62
35	2.6859.091.0	2	clamp
36	0.075.1452.0/10	1	sleeve
37	2.1519.117.0	12	special oil seal

9_33714_00_0_0

INLET AND EXHAUST VALVES

Fig.	P/n	QTY	Name
------	-----	-----	------

Notes:
[SX-1200]

1	0.066.1421.0	6	exhaust valve
2	0.010.6016.0	6	inlet valve mm 43.63 / Ø mm 9

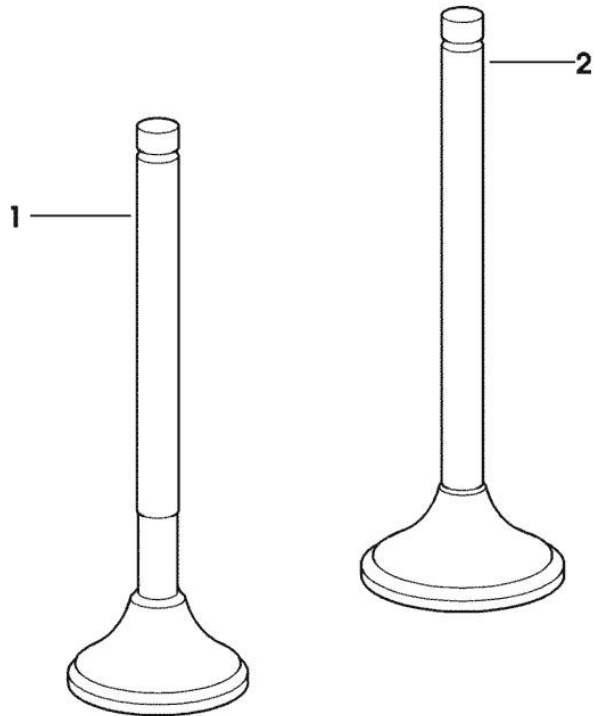

9_33614_01_0_0

OIL PAN - FOR TYPES WITHOUT SUSPENSION

Fig.	P/n	QTY	Name
------	-----	-----	------

Notes:
[SX-1200]

2	2.3199.001.2	2	plug 1/2" gas
3	2.1560.054.0	2	gasket 21 x 26
18	2.1470.004.2	34	lock washer 8
20	2.0112.215.2	25	screw m 8 p.1.25 x 40
21	0.010.9107.0/20	1	oil sump
22	2.0112.229.2	3	screw m 8 p.1.25 x 100
23	2.0112.235.2	2	screw m 8 p.1.25 x 130
24	2.0112.241.2	2	screw m 8 p.1.25 x 160
25	2.0112.243.2	2	screw m 8 p.1.25x170
26	2.1579.854.2	2	spacer 8.5x20x5

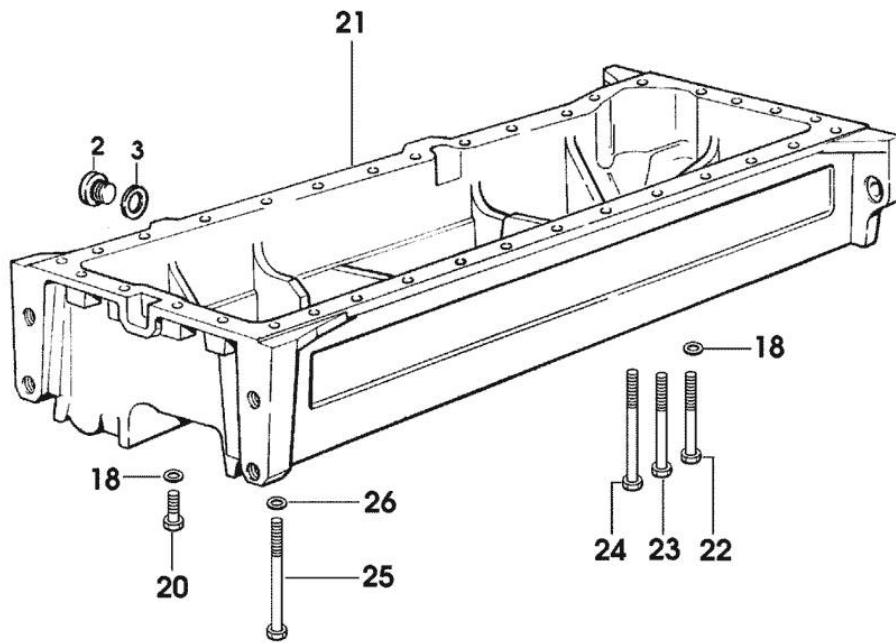

9_38415_02_0_0

Thank you so much for reading.
Please click the “Buy Now!”
button below to download the
complete manual.



After you pay.

You can download the most
perfect and complete manual in
the world immediately.

Our support email:

ebooklibonline@outlook.com