

**CRANKCASE**

Fig.	P/n	QTY	Name
------	-----	-----	------

**Notes:**

[TIGER 70 E 2WD ->S10S653WX1E1001] [TIGER 70 E 4WD ->S10S653WT1E1001]

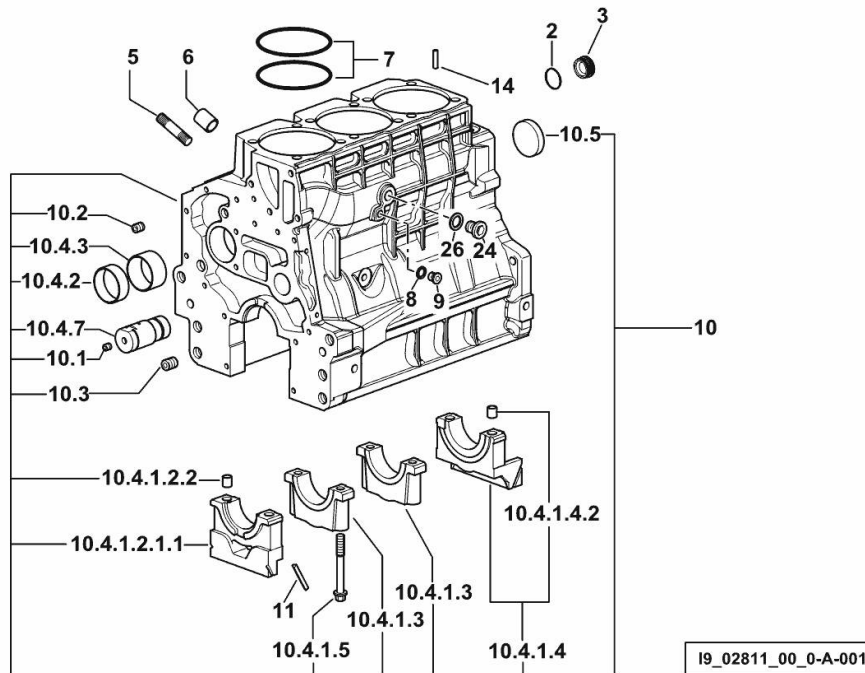

2	2.1532.072.0	1	oil seal 26.70x1.78
3	2.3199.405.2	1	plug m 28 p.1.5
5	2.0432.003.7	9	stud bolt m 8 p.1.25 / p.1 x 20
6	2.1559.188.2	3	bush 11.4 x 14 x16
7	2.1539.259.0	6	special oil seal 107.62x2.62
8	2.1560.010.0	1	gasket 14.2 x 20
9	2.3199.292.0	1	plug 1/4" gas
10	0.070.1110.6/20	1	crankcase
10.1	2.3130.001.1	9	plug 1/8" gas
10.2	2.3130.002.1	2	plug 1/4" gas
10.3	2.3130.003.1	2	plug 3/8" gas
10.4.1.2.1.1	0.065.1112.7/10	1	support
10.4.1.2.2	2.1699.165.0	1	bush 12.3x15x16
10.4.1.3	0.065.1114.0/10	2	support
10.4.1.4	0.065.1116.3	1	support
10.4.1.4.2	2.1699.165.0	1	bush 12.3x15x16
10.4.1.5	0.065.1117.0	8	screw m 12 x 100
10.4.2	0.065.1140.0	3	special bushing 59X55X20
10.4.3	0.065.1141.0	1	special bushing 59X55X30
10.4.7	0.066.1151.0	1	pin L= 87 mm
10.5	2.3179.012.0	1	plug 60
11	0.066.1152.0/10	4	gasket
14	2.1549.154.2	3	bush 4.8x5.8x16
24	2.3120.101.0	1	plug m 18 p.1.5
26	2.1560.014.0	1	washer 18.2 x 24

TIGER 70 E ->S10S653WT1E1001

Section: B0 - ENGINE

Ref: B0.01.3 (1)

**MONOBLOC ENGINE-GEARBOX CONNECTING FLANGE**

Fig.	P/n	QTY	Name
------	-----	-----	------

**Notes:**

[TIGER 70 E 2WD ->S10S653WX1E1001] [TIGER 70 E 4WD ->S10S653WT1E1001]

1	0.015.8814.0	1	flange
2	2.0112.511.2	8	screw m 14 p.2 x 30
3	2.0432.255.7	2	stud bolt m 12 p.1.75-1.25x25
4	2.1651.912.0	4	cylindrical plug 12x28
5	2.0512.404.7	2	screw

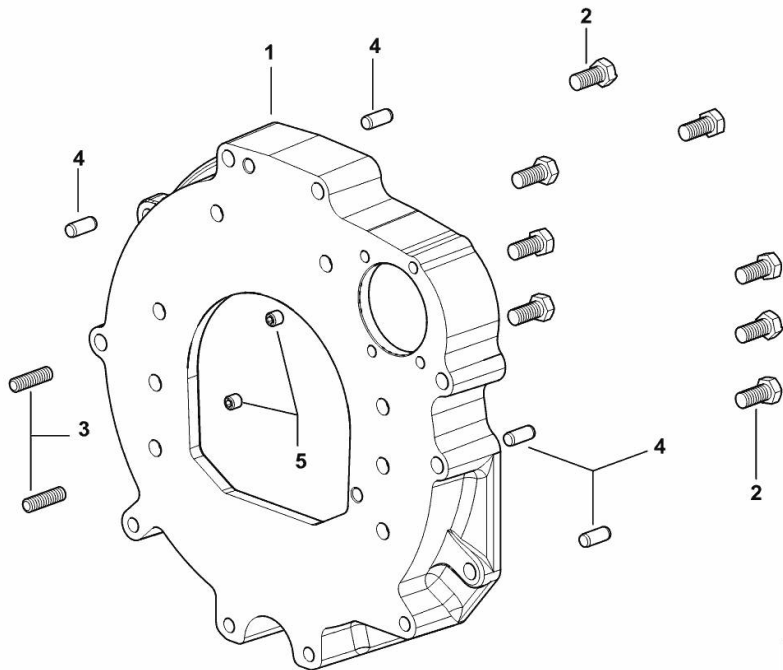

**CRANKSHAFT**

Fig.	P/n	QTY	Name
------	-----	-----	------

**Notes:**

[TIGER 70 E 2WD ->S10S653WX1E1001] [TIGER 70 E 4WD ->S10S653WT1E1001]

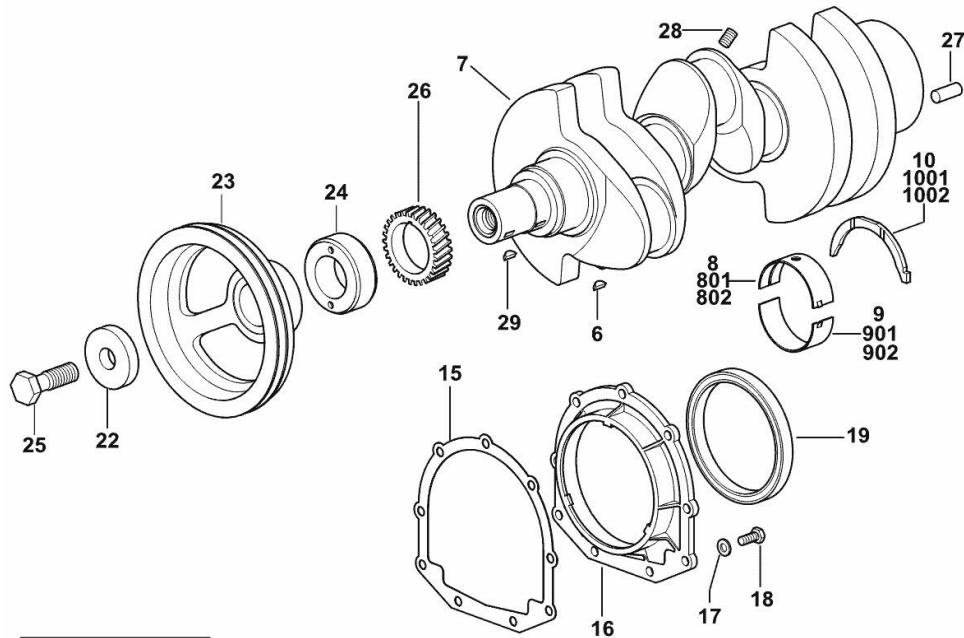

6	2.1720.006.0	1	key 4x6.5
7	0.007.1554.0/20	1	crankshaft
8	0.065.1215.0/10	4	main half bushing STANDARD
9	0.065.1216.0/10	4	main half bushing STANDARD
10	0.065.1218.0	4	shim STANDARD
15	0.065.1254.0/20	1	gasket
16	0.007.1711.0/10	1	cover
17	2.1475.002.2	9	conical washer 8
18	2.0112.207.2	9	screw m 8 p 1.25 x 20
19	2.1529.073.0	1	special oil seal 110x130x13
22	2.1599.524.7	1	washer 21x60x12
23	0.014.5093.0	1	pulley
24	0.085.1248.0/20	1	hub
25	2.0399.144.7/10	1	screw m 20 p.1.5x51
26	0.065.1323.0/30	1	gear Z = 29
27	2.1651.915.0	1	pin 12x35
28	2.3130.001.1	3	plug 1/8" gas
29	2.1720.006.0	1	key 4x6.5
801	0.065.1215.7	1	main half bushing - mm 0.25
802	0.065.1215.8	1	main half bushing - mm 0.50
901	0.065.1216.7	1	main half bushing - mm 0.25
902	0.065.1216.8	1	main half bushing - mm 0.50
1001	0.065.1218.7	1	shim + mm 0.10
1002	0.065.1218.8	1	shim + mm 0.15

19\_O2812\_00\_0-A-001

**ENGINE FLYWHEEL**

Fig.	P/n	QTY	Name
------	-----	-----	------

**Notes:**

[TIGER 70 E 2WD ->S10S653WX1E1001] [TIGER 70 E 4WD ->S10S653WT1E1001]

1	0.012.0925.3	1	flywheel
1.2	0.069.1242.0	1	crown wheel Z = 121
2	2.0119.174.0/10	6	screw m 12 p.1.25x45
3	2.2041.008.9	1	ball bearing 20x47x14

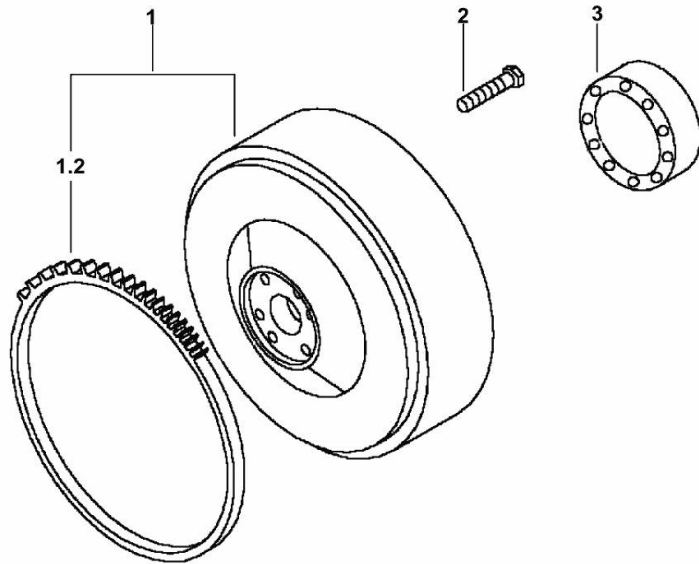

19\_38512\_02\_0-A-001

**ENGINE FLYWHEEL**

Fig.	P/n	QTY	Name
------	-----	-----	------

**Notes:**

- FOR TYPES WITH DOUBLE CLUTCH [TIGER 70 E 2WD ->S10S653WX1E1001] - FOR TYPES WITH DOUBLE CLUTCH [TIGER 70 E 4WD ->S10S653WT1E1001]

1	0.007.1617.3/30	1	flywheel
1.2	0.069.1242.0	1	crown wheel Z = 121
2	2.0119.174.0/10	6	screw m 12 p.1.25x45
3	2.2041.008.9	1	ball bearing 20x47x14

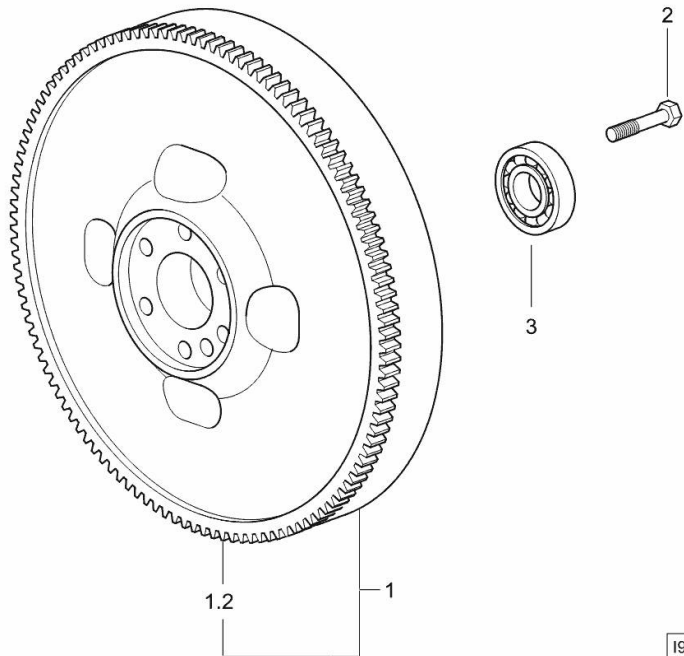

19\_38512\_12\_0-A-001

**COOLANT PUMP DRIVEBELT**

Fig.	P/n	QTY	Name
------	-----	-----	------

**Notes:**

[TIGER 70 E 2WD ->S10S653WX1E1001] 1061 <- [TIGER 70 E 4WD ->S10S653WT1E1001] 1061 <-

3	2.4119.139.0	1	belt mm 10.7x1254
---	--------------	---	-------------------

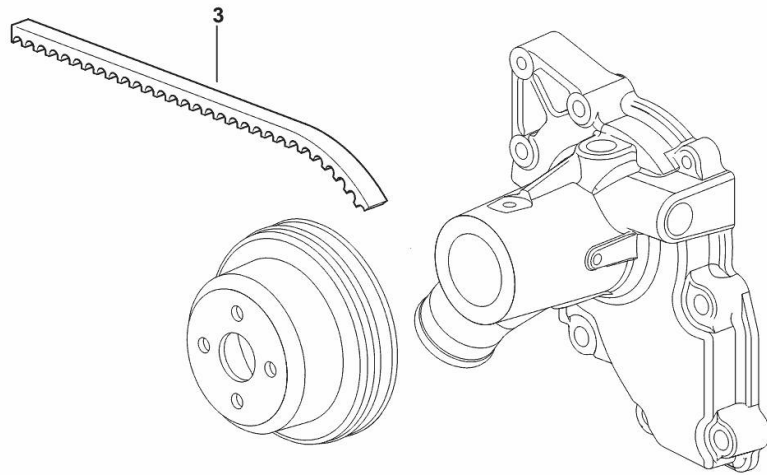

19\_O2817\_02\_0-B-001

**COOLANT PUMP AND ALTERNATOR DRIVEBELT**

Fig.	P/n	QTY	Name
------	-----	-----	------

**Notes:**  
[TIGER 70 E 2WD ->S10S653WX1E1001]-> 1062 [TIGER 70 E 4WD ->S10S653WT1E1001] -> 1062

3	2.4119.198.0	1	vee belt AV 10.7x1240 mm
---	--------------	---	--------------------------

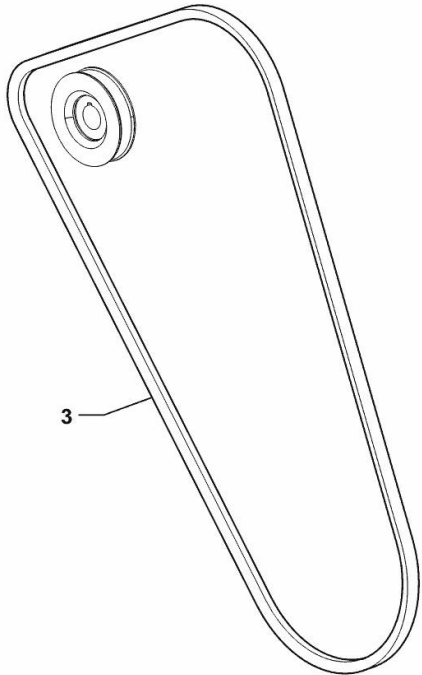

19\_O2519\_11\_0-A-001

**CYLINDER - PISTON - CONNECTING ROD**

Fig.	P/n	QTY	Name
------	-----	-----	------

**Notes:**

[TIGER 70 E 2WD ->S10S653WX1E1001] [TIGER 70 E 4WD ->S10S653WT1E1001]

1	0.388.0065.A	3	cyl. piston assembly "A" - CLASS A
1	0.388.0065.B	3	cyl. piston assembly "B" - CLASS B
1.1	0.A12.2675.0	1	engine cylinder "A" - CLASS A
1.1	0.B12.2675.0	1	engine cylinder "B" - CLASS B
1.2	0.381.0060.A	1	complete piston "A" - CLASS A
1.2	0.381.0060.B	1	complete piston "B" - CLASS B
1.2.1	0.338.0052.6/20	1	piston ring set
1.2.2	2.1411.014.1	2	circlip 35
1.2.3	0.078.1236.0	1	piston pin Ø 18 / Ø 35 / L = mm 86
2	0.065.1225.0	6	con.rod half bushing STANDARD - A = 28.75 -> 29.00
2	0.065.1225.7	6	con.rod half bushing - mm 0.25
2	0.065.1225.8	6	con.rod half bushing - mm 0.50
3	0.078.1220.3/30	3	engine connecting rod
3.1	2.0399.213.0	2	screw m 12 p.1.25x61.5
3.2	2.1559.114.0/10	1	special bushing

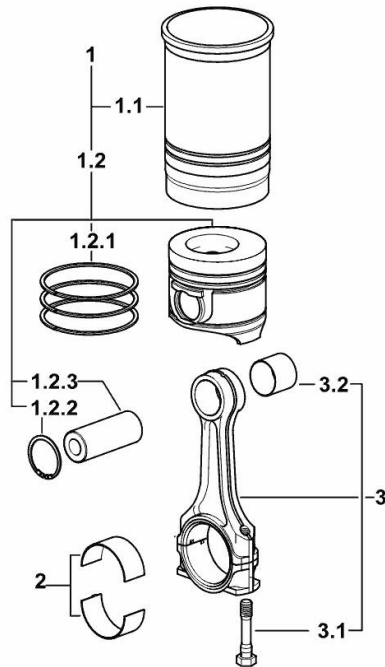

I9\_M7712\_03\_M-A-001



**CAMSHAFT**

Fig.	P/n	QTY	Name
------	-----	-----	------

**Notes:**

[TIGER 70 E 2WD ->S10S653WX1E1001] [TIGER 70 E 4WD ->S10S653WT1E1001]

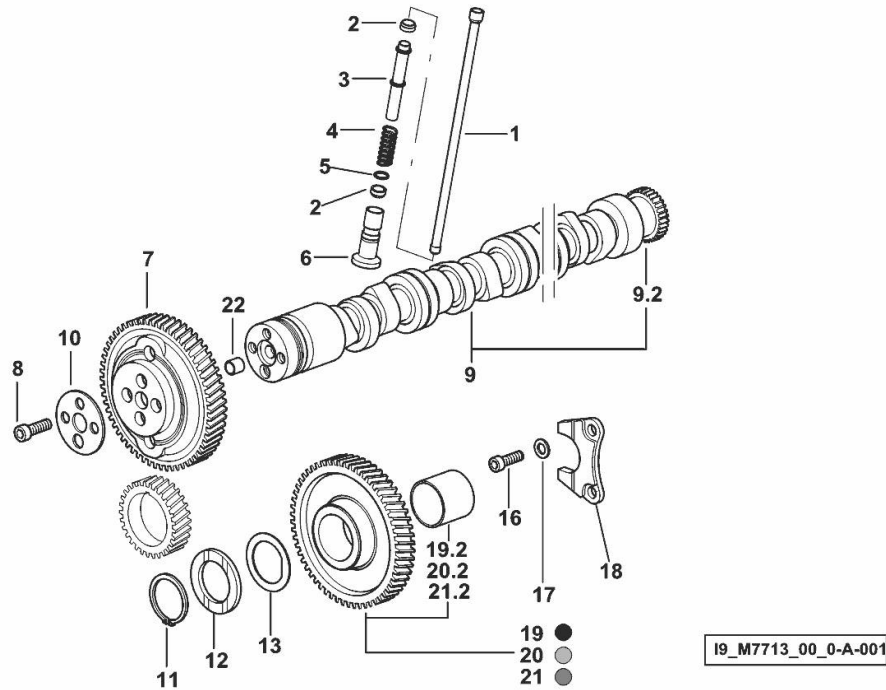

1	0.065.1331.2	6	rod
2	2.1569.114.0/10	12	gasket 14x18.5x8
3	0.065.1332.0	6	sleeve
4	2.4019.300.1/10	6	spring 18.5x52x2
5	2.1599.437.0	6	shoulder ring
6	0.065.1330.0	6	tappets
7	0.013.5017.0	1	gear z=58
8	2.0132.207.2	4	screw m 10 p.1 x 25
9	0.009.7456.3/10	1	camshaft
9.2	0.065.1324.0/10	1	gear Z = 32
10	0.065.1350.0	1	small disc
11	2.1410.016.1	1	circlip 40
12	0.065.1352.0	1	shim
13	0.018.2233.0	2	shoulder ring
16	2.0312.205.2	2	screw
17	2.1480.014.1	2	washer 8
18	0.065.1353.0	1	small plate
19	0.007.1177.3/20	0.4	gear z = 57 - WITH RED IDENTIFICATION STAMP
19.2	2.1559.185.0/10	1	bushing
20	0.007.1178.3/20	0.4	gear z = 57 - WITH YELLOW IDENTIFICATION STAMP
20.2	2.1559.185.0/10	1	bushing
21	0.007.1179.3/20	0.2	gear z = 57 - WITH GREEN IDENTIFICATION STAMP
21.2	2.1559.185.0/10	1	bushing
22	2.1559.398.0	1	bushing 10.5x13x12

**TIMING CASE**

Fig.	P/n	QTY	Name
------	-----	-----	------

**Notes:**

[TIGER 70 E 2WD ->S10S653WX1E1001] [TIGER 70 E 4WD ->S10S653WT1E1001]

15	2.0432.003.7	2	stud bolt m 8 p.1.25 / p.1 x 20
16	2.0312.214.2	7	screw m 8 p.1.25 x 40
17	2.1480.014.1	15	washer 8
18	0.013.4981.0	1	guard
19	0.065.1150.0/30	1	gasket
20	2.1470.004.2	4	lock washer 8
21	2.1011.405.2	2	nut m 8 p.1
22	2.0312.208.2	8	screw m 8 p.1.25 x 25
23	2.1529.167.0	1	oil seal

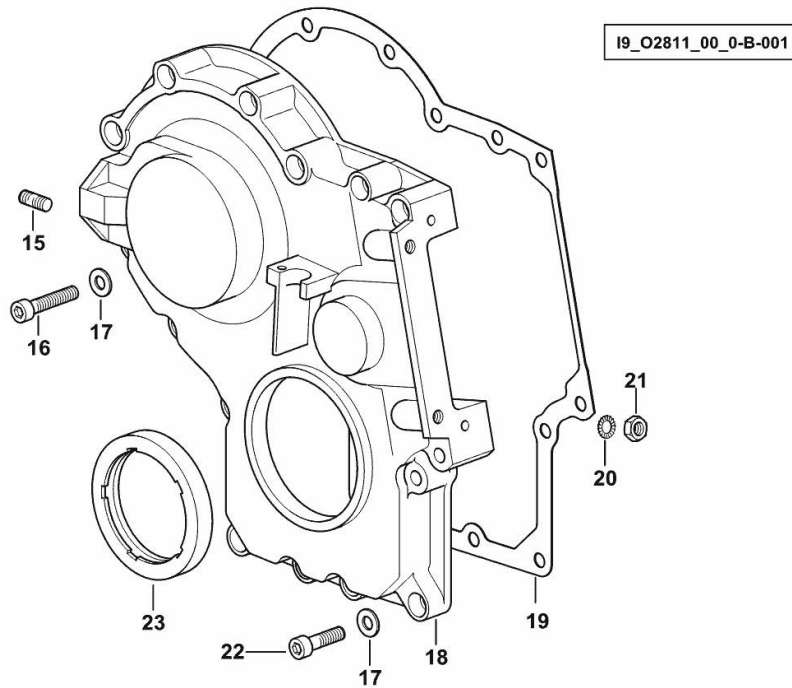

**GUARD PLATE**

Fig.	P/n	QTY	Name
------	-----	-----	------

**Notes:**

[TIGER 70 E 2WD ->S10S653WX1E1001] [TIGER 70 E 4WD ->S10S653WT1E1001]

1	0.007.1262.3/50	1	guard
2	0.012.0707.0	1	small column m 8 p.1.25 / L = mm 60
3	0.012.0708.0	2	small column m 8 p.1.25 / L = mm 50
5	2.1310.004.2	3	flat washer 8.4x17
7	2.0112.203.2	3	screw m 8 p.1.25 x 12

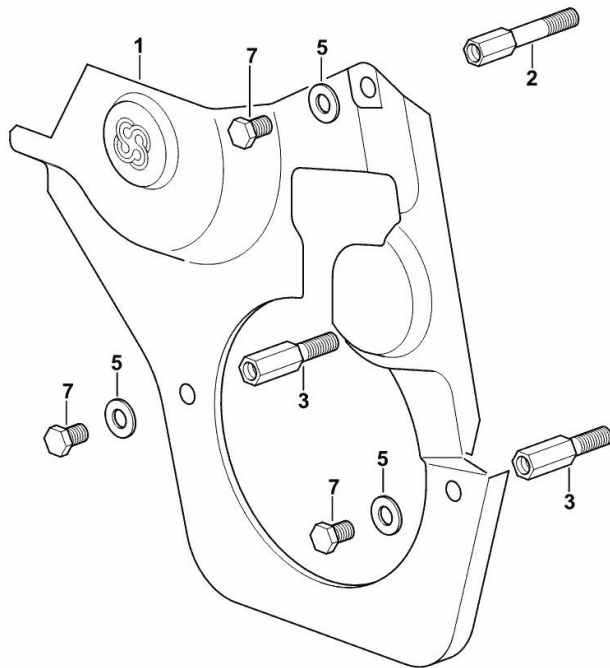

19\_N8911\_03\_0-A-001

Section: B0 - ENGINE  
**CYLINDER HEAD**

Fig.	P/n	QTY	Name
------	-----	-----	------

Notes:

[TIGER 70 E 2WD ->S10S653WX1E1001] [TIGER 70 E 4WD ->S10S653WT1E1001]

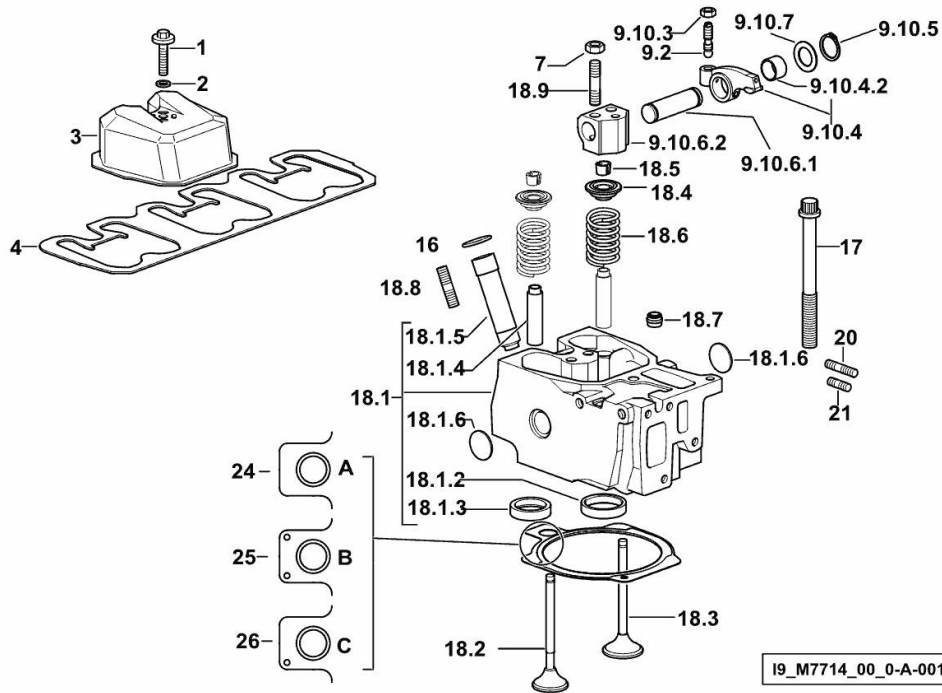

1	2.0399.288.2/10	3	screw m 8x36x46
2	2.1532.018.0	3	oil seal 9.19 x 2.62
3	0.016.0291.0	3	small cap
4	0.069.1450.0/30	1	tappet gasket
7	2.1011.421.2	6	nut m 10 p.1.25
9.2	0.021.1434.0	2	screw
9.10.3	2.1011.405.2	2	nut m 8 p.1
9.10.4	0.066.1432.3	2	rocker arm
9.10.4.2	2.1559.021.0/40	1	bushing 15x19x22
9.10.5	2.1410.055.7	2	circlip 19
9.10.6.1	0.066.1431.0	1	pin
9.10.6.2	0.066.1430.0/10	1	support
9.10.7	2.1599.432.0	2	shoulder ring
16	2.1530.051.0	3	oil seal 20.22x3.53
17	0.012.2673.0	12	screw m 14 p.2x141
18.1	0.015.9713.3/10	1	engine head
18.1.2	0.078.1426.0	1	valve seat
18.1.3	0.066.1427.0	1	valve seat
18.1.4	0.007.1779.0/20	2	valve guide
18.1.5	0.010.6041.0/10	1	bush
18.1.6	2.3170.012.2	2	expansion plug Ø 30
18.2	0.010.6022.0	1	exhaust valve mm 39.1 / Ø mm 9
18.3	0.010.6017.0	1	inlet valve mm 43.63 / Ø mm 9
18.4	0.066.1425.0	2	cup
18.5	0.074.1423.0	4	conical valve cotter
18.6	2.4019.287.0	2	spring
18.7	2.1519.117.0	2	special oil seal
18.8	2.0432.161.7	1	stud bolt m 10 p.1.5 / p.1.25 x 40
18.9	2.0432.163.7	2	stud bolt m 10 p.1.5 / p.1.25 x 45
20	2.0432.011.7	3	stud bolt m 8 p.1.25 / p.1 x 40
21	2.0432.005.7	3	stud bolt m 8 p.1.5 / p.1 x 25
24	0.078.1451.0/60	0.5	head gasket - A - mm 1.2
25	0.078.1452.0/50	2	head gasket - B - mm 1.4
26	0.078.1453.0/60	0.5	head gasket - C - mm 1.6

**ENGINE OIL PUMP**

Fig.	P/n	QTY	Name
------	-----	-----	------

**Notes:**

[TIGER 70 E 2WD ->S10S653WX1E1001] [TIGER 70 E 4WD ->S10S653WT1E1001]

35	0.065.1560.0/30	2	gasket
36	2.0169.005.2	2	screw m 6 p.1 x 12
37	2.1652.711.0	2	cylindrical plug 8x25
38	0.075.1551.4/30	1	support
38.1	0.075.1551.3/40	1	support
38.1.2	2.1559.186.0	1	special bushing 26 x 31.5 x 35
38.2	2.1219.025.2/10	1	ring nut m 36 p.1.5
38.3	2.1410.057.1	1	circlip 15
38.4	2.1589.153.0	1	shoulder ring 15.2 x 19 x 1.00
38.5	2.1589.146.0	2	shoulder ring 15.2 x 19 x 0.15
38.6	2.1589.147.0	2	shoulder ring 15.2 x 19 x 0.10
38.7	2.2020.001.0	1	ball bearing 15 x 32 x 8.00
38.8	2.1589.148.0	1	shoulder ring 28.2 x 31.8 x 0.5
38.9	2.1589.150.0	2	shoulder ring 28.2 x 31.8 x 0.1
38.10	2.1589.151.0	2	shoulder ring 28.2 x 31.8 x 0.15
38.11.1	0.065.1558.6/10	1	bevel drive
38.11.2	0.065.1559.0	1	bush
38.12	2.2680.020.0	1	ring 12 x 15 x 12
38.13	2.2725.016.0	1	roller cage 15 x 21 x 12
38.14	2.0342.007.2	1	screw m 4 p.0.7x25
38.15	2.0399.128.2/10	1	screw m 8 p.1 x 8
38.16	2.2030.002.0	1	ball bearing 12 x 28 x 8
40	0.065.1569.0/40	1	shaft
41	0.065.1562.0/10	1	joint
42	0.014.7994.4	1	oil pump
43	2.1470.006.2	2	lock washer 10
44	2.0112.323.2	2	screw m 10 p.1.5x70

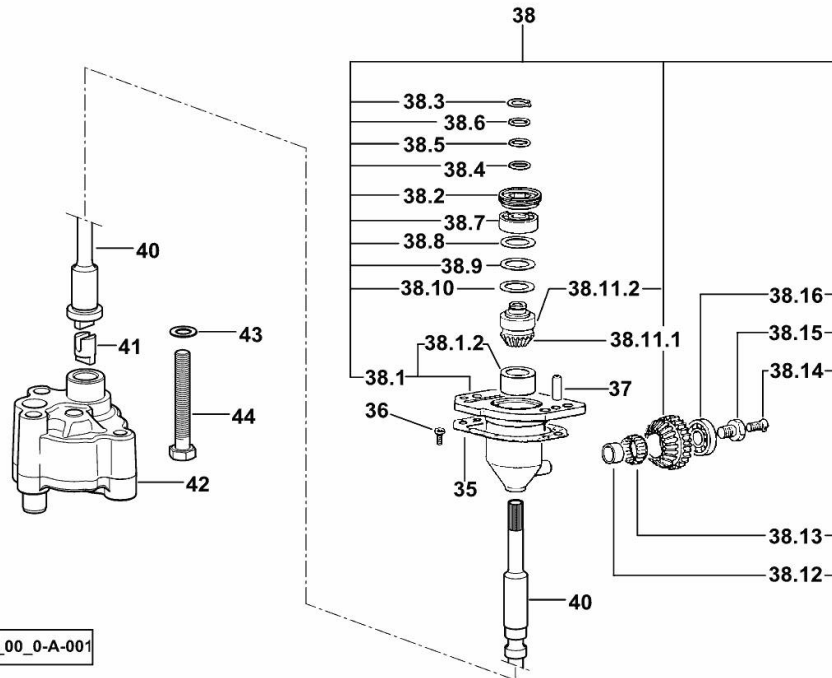

19\_N8915\_00\_0-A-001

**LUBRICATION**

Fig.	P/n	QTY	Name
------	-----	-----	------

**Notes:**

[TIGER 70 E 2WD ->S10S653WX1E1001] [TIGER 70 E 4WD ->S10S653WT1E1001]

1	0.065.1160.3/20	3	valve
50	2.1099.108.2	3	special nut m 10 p.1
51	2.1560.006.0	12	gasket 10.2 x 16
52	0.086.1550.2	3	sprayer nozzle
55	2.0312.221.2	2	screw m 8 p.1.25x75
56	2.1480.014.1	2	washer 8
57	0.012.0688.4	1	sediment bowl
57.1	0.066.1553.0	1	cover
57.2	0.066.1554.0/20	1	gasket
57.3	2.0399.304.2	4	screw m 4 x 10
57.4.1	0.066.1555.0	1	tube
57.4.2	0.012.0688.0	1	small tank
58	2.1532.012.0	1	oil seal 6.75 x 1.78
59	2.1539.072.0	2	special oil seal 23.52 x 1.78
60	0.066.1558.0	1	bush
61	0.066.1557.2	1	tube
62	2.3350.003.1	1	nosepiece 8
63	2.3339.418.1	1	pipe fitting m 12 p.1
65	0.007.1427.0	1	tube
66	0.002.8816.0	1	small plate
67	2.0112.007.2	1	screw m 6 p.1 x 20
68	2.1011.103.2	1	nut m 6 p.1
69	2.1470.002.2	1	lock washer 6

19\_N8915\_00\_0-C-001

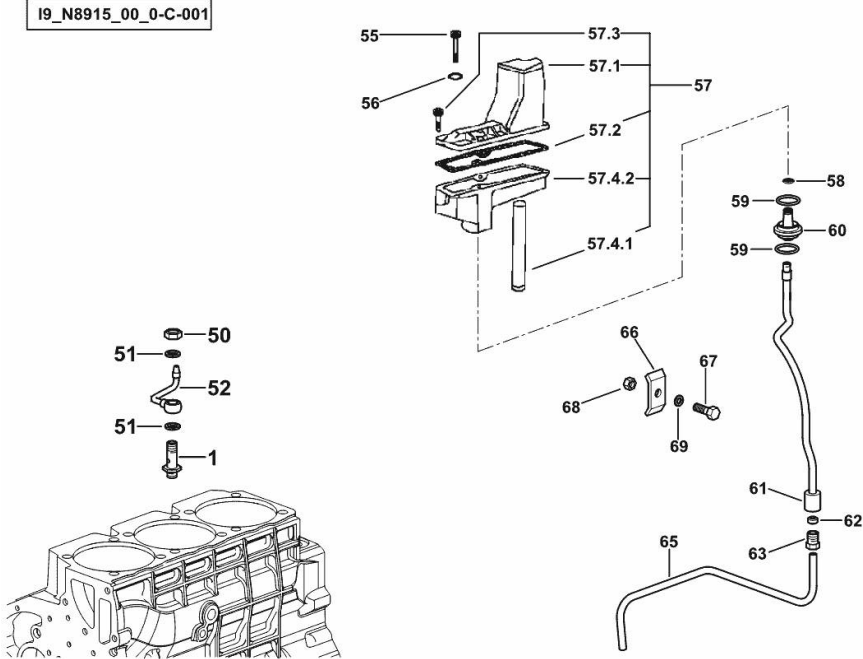

**FUEL SETTLING FILTER VENT HOSE BRACKET**

Fig.	P/n	QTY	Name
------	-----	-----	------

Notes:  
[TIGER 70 E 2WD ->S10S653WX1E1001] [TIGER 70 E 4WD ->S10S653WT1E1001]

8	0.075.1151.0	1	bracket
---	--------------	---	---------

19\_O2884\_50\_0-B-001

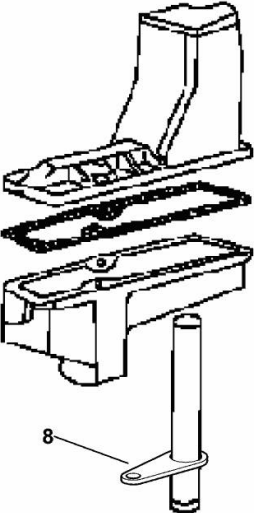

Thank you so much for reading.  
Please click the “Buy Now!”  
button below to download the  
complete manual.



After you pay.

You can download the most  
perfect and complete manual in  
the world immediately.

Our support email:

[ebooklibonline@outlook.com](mailto:ebooklibonline@outlook.com)