

LIGHT ENGINE

Fig.	P/n	QTY	Name
------	-----	-----	------

Notes:
 [XA 85 -> ZKDCW40200TH10001]

1	I6.IF701.00.0	1	engine ON ORDERING PLEASE ENGINE NO. REQUIRED
---	---------------	---	---

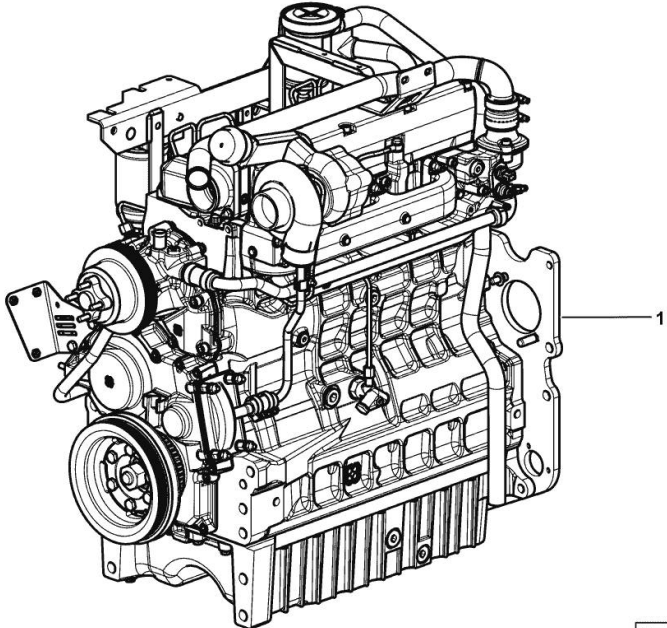

19_MTCV3_00_M-A-001

CRANKCASE

Fig.	P/n	QTY	Name
------	-----	-----	------

Notes:
 [XA 85 -> ZKDCW40200TH10001]

3	2.3199.312.2/20	1	plug m 35x1.5x9.5
5	2.0439.279.7	8	stud bolt m 8 p.1 x 25
6	2.1559.188.2	4	bush 11.4 x 14 x16
7	2.1539.259.0	8	special oil seal 107.62x2.62
8	2.1560.010.0	1	gasket 14.2 x 20
9	2.3199.292.0	1	plug 1/4" gas
10	0.014.9655.4/30	1	crankcase
10.1	2.3130.001.1	14	plug 1/8" gas
10.2	2.3130.002.1	4	plug 1/4" gas
10.3	2.3130.003.1	6	plug 3/8" gas
10.4.1.1.1	0.065.1112.7/10	1	support
10.4.1.2	2.1699.165.0	1	bush 12.3x15x16
10.4.2	0.065.1114.0/10	3	support
10.4.3	0.065.1116.3	1	support
10.4.3.2	2.1699.165.0	1	bush 12.3x15x16
10.4.8	0.065.1117.0	10	screw m 12 x 100
10.5	2.3179.012.0	1	plug 60
10.6	0.065.1140.0	4	special bushing 59X55X20
10.7	0.065.1141.0	1	special bushing 59X55X30
10.8	0.014.1340.0/10	1	pin mm 85
11	0.066.1152.0/10	4	gasket
13	2.1549.154.2	4	bush 4.8x5.8x16
25	0.013.4946.0/10	1	sprayer nozzle
26	2.3120.101.0	1	plug m 18 p.1.5
28	2.1560.014.0	1	washer 18.2 x 24

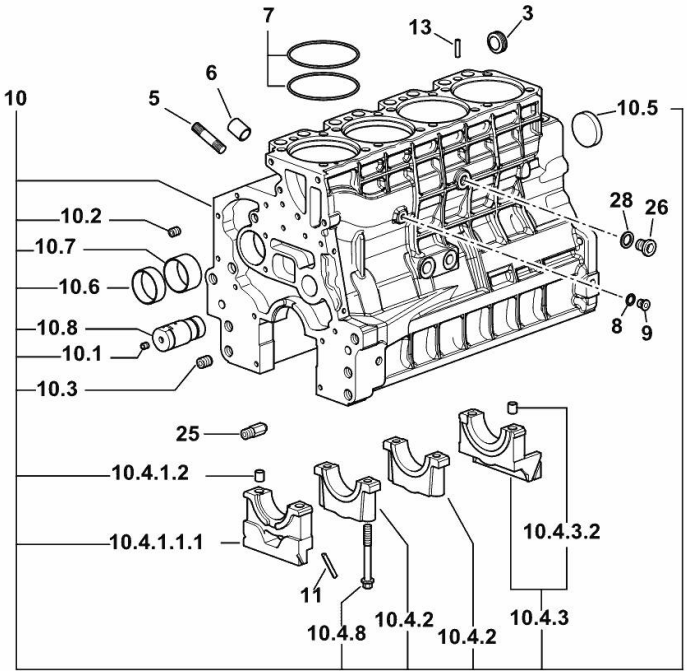

19_O1011_00_0-A-001

MONOBLOC ENGINE-GEARBOX CONNECTING FLANGE

Fig.	P/n	QTY	Name
------	-----	-----	------

Notes:
 [XA 85 -> ZKDCW40200TH10001]

1	0.007.7752.0/30	1	flange
2	2.0112.511.2	8	screw m 14 p.2 x 30
3	2.1651.912.0	2	cylindrical plug 12x28
4	2.1651.917.0	1	cylindrical plug 12x40
5	2.0432.257.7	1	stud bolt m 12 p.1.75 - 1.25 x 30
6	2.0439.250.7	1	stud bolt m 12 / m 10 x 30
7	0.011.9294.0/10	1	bush

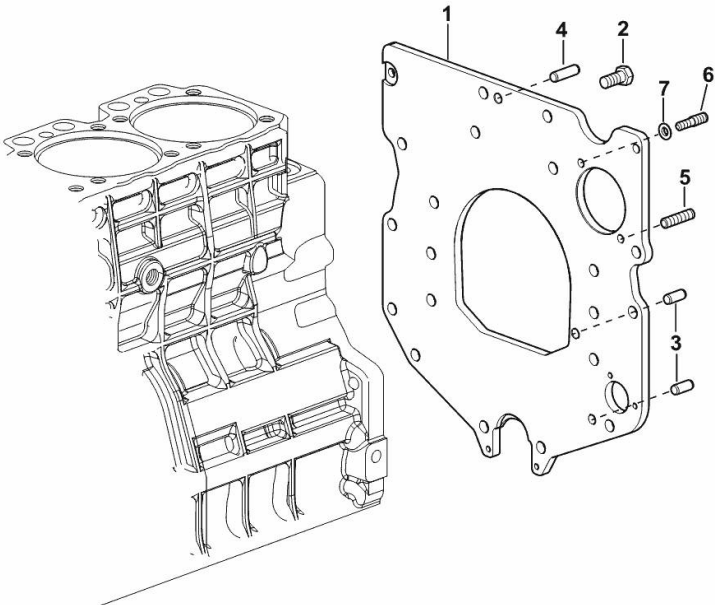

19_N8911_01_0-A-001

LOWER PLUG FOR CYLINDER BLOCKS

Fig.	P/n	QTY	Name
------	-----	-----	------

Notes:
 [XA 85 -> ZKDCW40200TH10001]

1	2.3130.003.1	2	plug 3/8" gas
---	--------------	---	---------------

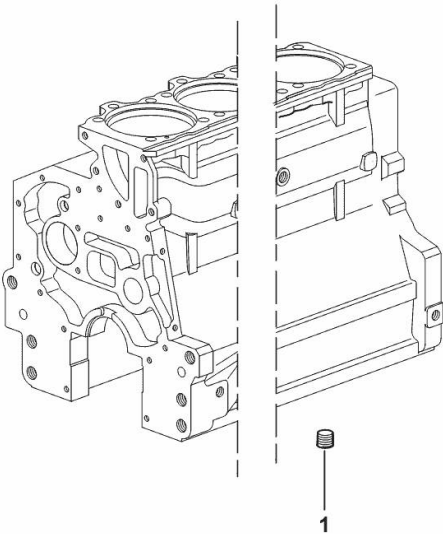

19_37511_06_0-A-001

SIDE PLUG FOR CYLINDER BLOCK

Fig.	P/n	QTY	Name
------	-----	-----	------

Notes:
[XA 85 -> ZKDCW40200TH10001]

22	2.1560.017.0	1	gasket 22.2 x 27
23	2.3120.002.4	1	plug m 22 x 1.5

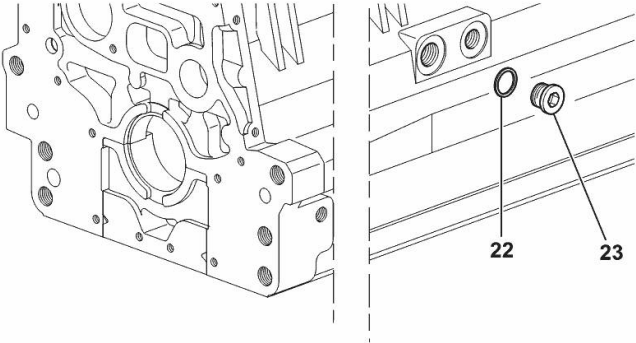

I9_33211_07_0-A-001

ENGINE OIL AND TURBO PRESSURE SWITCH UNION

Fig.	P/n	QTY	Name
------	-----	-----	------

Notes:
 [XA 85 -> ZKDCW40200TH10001]

10	2.3339.787.0/10	1	pipe fitting 7/16"
11	2.3110.403.1	1	plug m 14 p.1.5x12
13	2.1019.129.2/10	1	nut m 18 p.1.5x12
14	2.1533.038.0	1	oil seal 15.45x2.62
15	2.1560.010.0	2	gasket 14.2 x 20

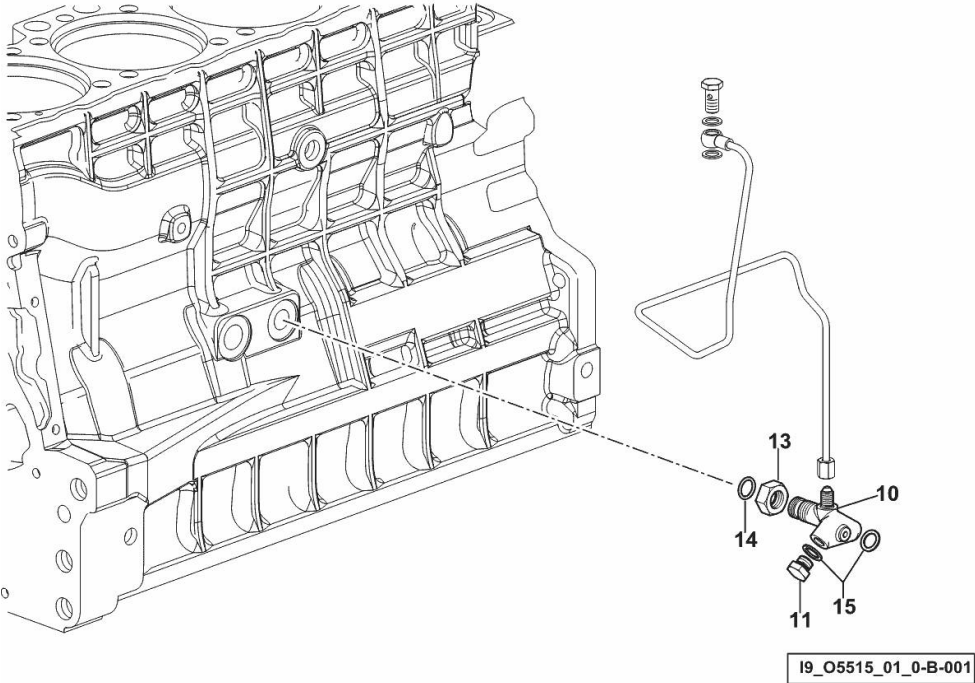

ENGINE FLYWHEEL

Fig.	P/n	QTY	Name
------	-----	-----	------

Notes:
 [XA 85 -> ZKDCW40200TH10001]

1	0.014.2693.3	1	flywheel
1.2	0.065.1242.0	1	crown wheel Z = 123
2	2.0139.036.2	6	screw m 12 p.1.25 x 35

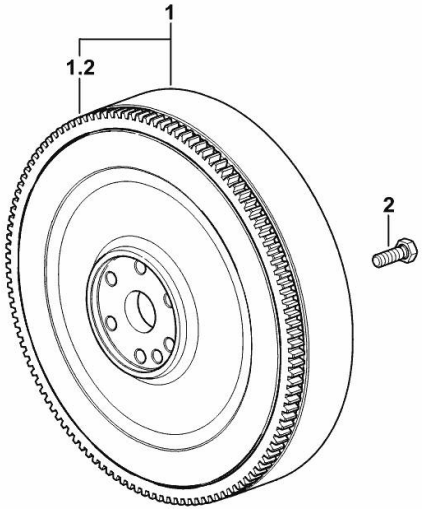

9_N1312_02_0-A-001

CRANKSHAFT

Fig.	P/n	QTY	Name
------	-----	-----	------

Notes:
[XA 85 -> ZKDCW40200TH10001]

2	0.021.8246.3	1	crankshaft
2.2	0.065.1211.0/10	1	crown wheel
2.3	2.1630.608.0	1	pin 6x16
4	0.019.5455.0	5	main half bushing STANDARD
5	0.019.5456.0	5	main half bushing STANDARD
6	0.065.1218.0	4	shim STANDARD
8	2.1599.524.7	1	washer 21x60x12
9	2.1589.189.0	2	shoulder ring mm 1.00
11	2.1529.073.0	1	special oil seal 110x130x13
14	0.065.1254.0/20	1	gasket
15	0.007.1711.0/10	1	cover
16	2.1475.002.2	9	conical washer 8
17	2.0112.207.2	9	screw m 8 p 1.25 x 20
18	2.1720.006.0	1	key 4x6.5
19	0.065.1323.0/30	1	gear Z = 29
20	2.1651.915.0	1	pin 12x35
601	0.065.1218.7		shim + mm 0.10
602	0.065.1218.8		shim + mm 0.15

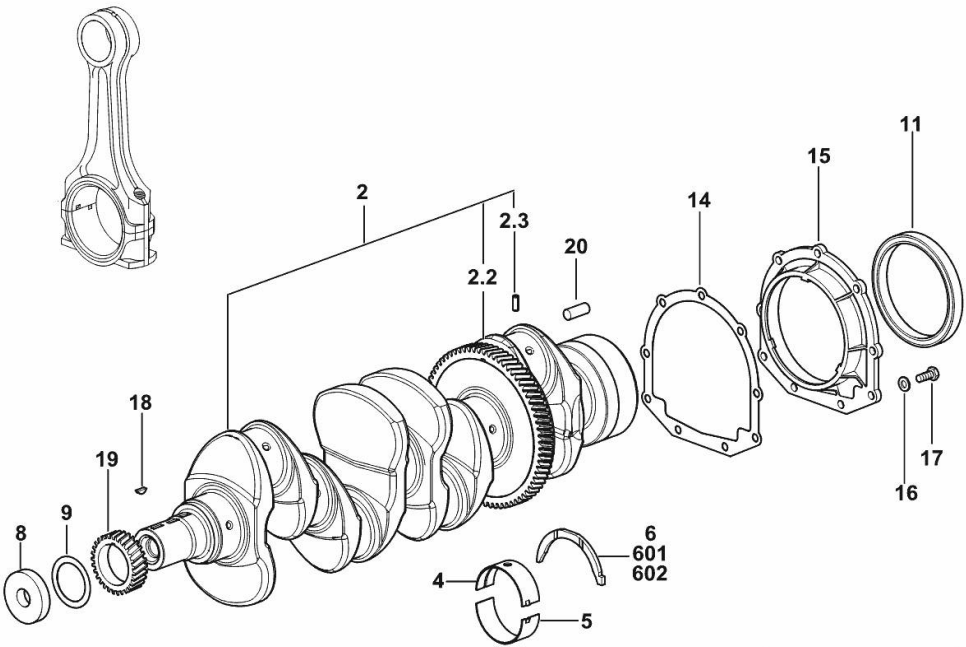

19_Q8012_00_0-A-002

ENGINE CRANKSHAFT PULLEY WITH RING-FEEDER RINGS

Fig.	P/n	QTY	Name
------	-----	-----	------

Notes:
 [XA 85 -> ZKDCW40200TH10001]

1	0.015.6055.0	1	pulley
2	0.011.3515.0/20	1	hub Z = 48
3	0.065.1256.0	2	ring 45x52
4	2.1579.865.0	1	spacer 45.2x51.8x10
5	2.0439.195.7	1	stud bolt m 20 p.1.5x80
6	2.1019.094.7	1	nut m 20 p.1.5
7	2.0112.320.2	6	screw m 10 p.1.5 x 55
8	2.1470.006.2	6	lock washer 10

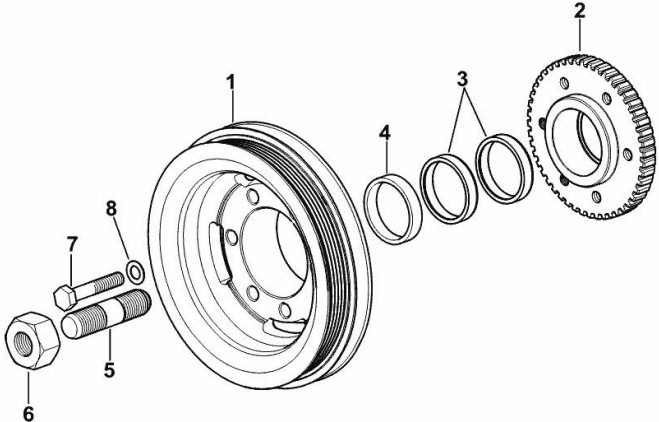

I9_O6312_03_0-A-001

COOLANT PUMP DRIVEBELT

Fig.	P/n	QTY	Name
------	-----	-----	------

Notes:
- FOR TYPES WITHOUT CONDITIONING [XA 85 -> ZKDCW40200TH10001]

1	2.4119.214.0	1	belt PV-K5 (mm 17.4x1245)
---	--------------	---	-----------------------------

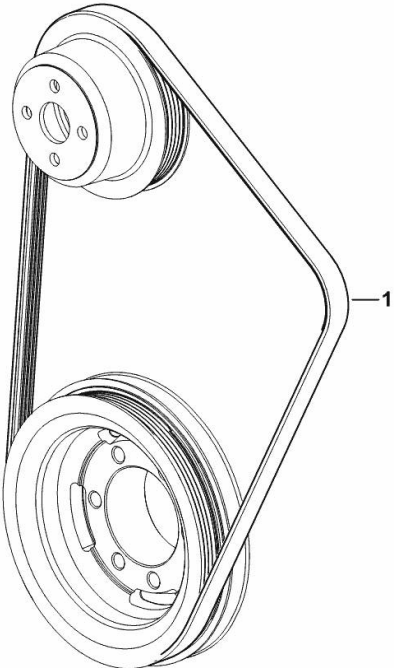

9_K7417_09_0-A-001

COOLANT PUMP AND ALTERNATOR DRIVEBELT

Fig.	P/n	QTY	Name
------	-----	-----	------

Notes:
- FOR MODELS WITH COMPRESSOR [XA 85 -> ZKDCW40200TH10001]

1	2.4119.143.0	1	belt AV 12.7x1225 mm
2	2.4119.214.0	1	belt PV-K5 (mm 17.4x1245)

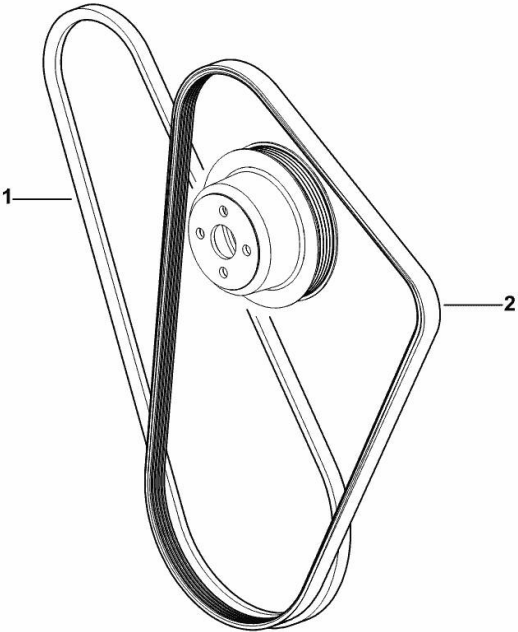

9_O6317_09_0-A-001

COUNTERWEIGHTS

Fig.	P/n	QTY	Name
------	-----	-----	------

Notes:
[XA 85 -> ZKDCW40200TH10001]

25	2.1589.139.0	1	shoulder ring mm 0.3
26	2.1589.140.0	3	shoulder ring mm 0.1
29	2.1579.628.0	3	spacer 16.5x26x0.1
33	2.1579.629.0	6	spacer 12.5x26x0.1
34	2.1589.048.0	1	shoulder ring 16.5x26x0.3
35	2.1589.049.0	1	shoulder ring 12.5x26x0.3
38.1.1	0.086.1231.0/10	1	box
38.1.2	2.3130.001.1	4	plug 1/8" gas
38.2	0.086.1233.3/30	1	mass sx/lh/li
38.2.2	2.1559.115.0	2	special bushing 26x30x30
38.2.4	2.1651.302.0	1	roll pin 4x6
38.3	0.065.1233.3/30	1	mass dx/rh/re
38.3.2	2.1559.115.0	2	special bushing 26x30x30
38.3.4	2.1651.302.0	1	roll pin 4x6
38.3.5	2.1410.018.1	1	circlip 45
38.4.1	0.065.1234.0/10	1	shaft
38.4.2	2.3130.001.1	1	plug 1/8" gas
38.5	2.1631.717.0	2	roll pin 8 x 40
38.6	2.1589.185.0	4	shoulder ring 26.1x34x1
38.7	2.0522.212.7	1	screw m 8 p.1.25 x 30
44	2.1579.626.0	2	spacer 13.2x16x11
45	2.0139.028.2	4	screw m 12
46	2.1699.191.0	1	bush 7x10x16

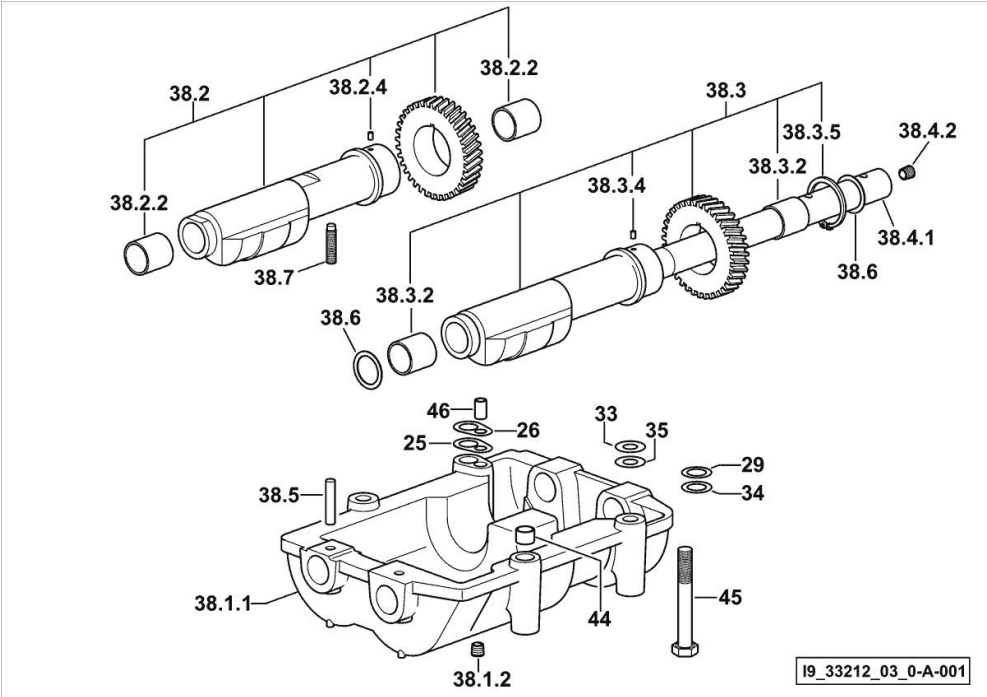

CYLINDER - PISTON - CONNECTING ROD

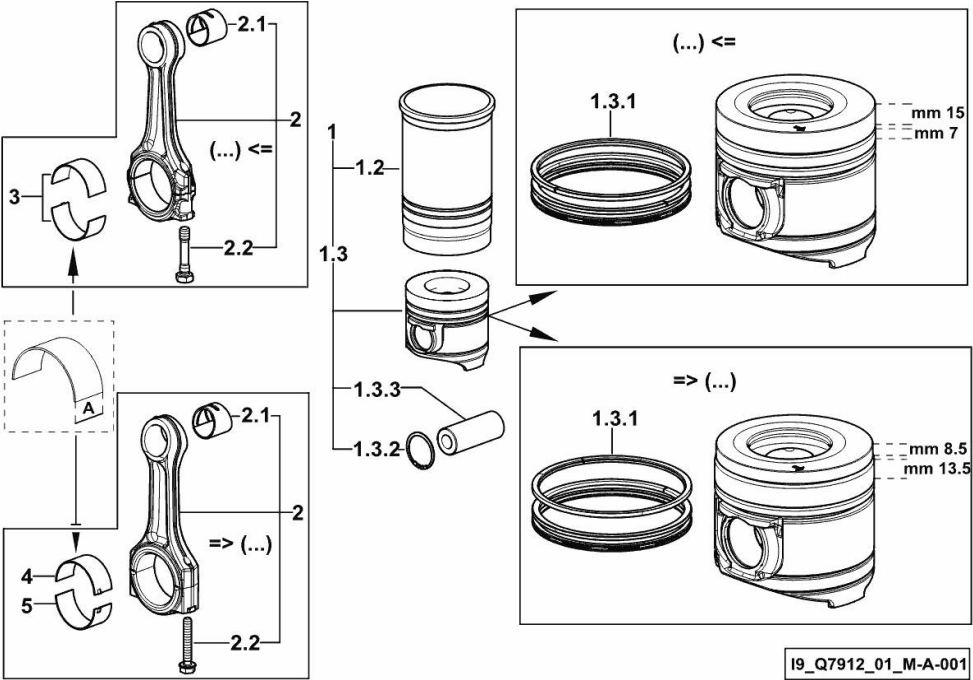
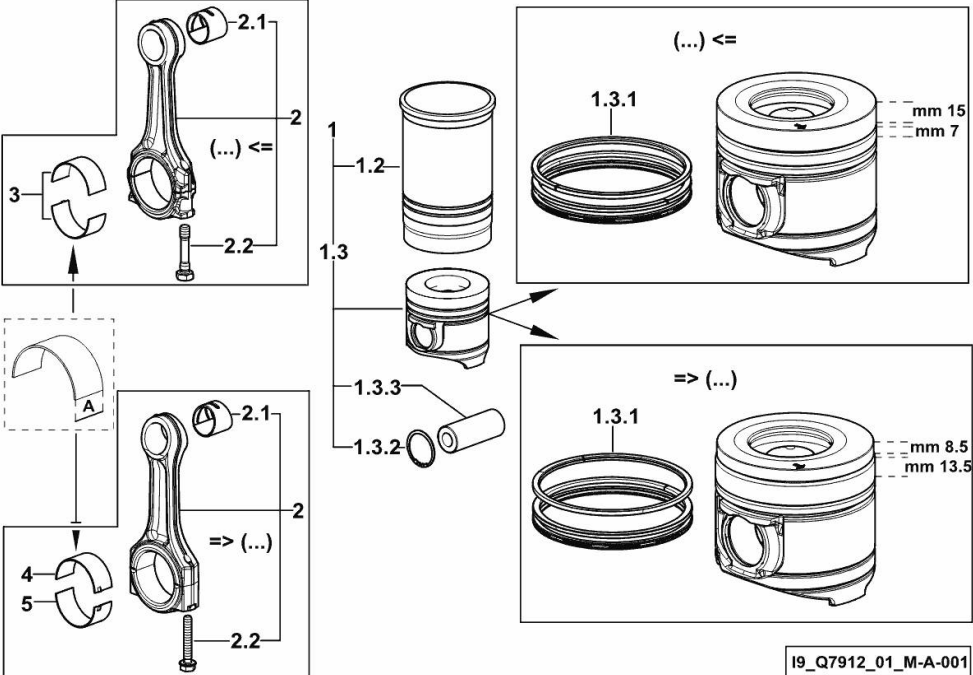

Fig.	P/n	QTY	Name
Notes:			
[XA 85 -> ZKDCW40200TH10001] 10002 <-			
1	0.O68.0065.A	4	cyl. piston assembly "A" (...) <= - CLASS A
1	0.O68.0065.B	4	cyl. piston assembly "B" (...) <= - CLASS B
1	0.Q92.0065.A	4	cyl. piston assembly "A" => (...) - CLASS A
1	0.Q92.0065.B	4	cyl. piston assembly "B" => (...) - CLASS B
1.2	0.A12.2675.0	1	engine cylinder "A" - CLASS A
1.2	0.B12.2675.0	1	engine cylinder "B" - CLASS B
1.3	0.O68.0060.A	1	complete piston "A" (...) <= - CLASS A
1.3	0.O68.0060.B	1	complete piston "B" (...) <= - CLASS B
1.3	0.Q92.0060.A	1	complete piston "A" => (...) - CLASS A
1.3	0.Q92.0060.B	1	complete piston "B" => (...) - CLASS B
1.3.1	0.081.0090.6/10	1	piston ring set (...) <=
1.3.1	0.Q92.0052.6	1	piston ring set => (...)
1.3.2	2.1411.014.1	2	circlip 35
1.3.3	0.078.1236.0	1	piston pin Ø 18 / Ø 35 / L = mm 86
2	0.014.5175.3	4	engine connecting rod (...) <=
2	0.019.2226.3/10	4	engine connecting rod => (...)
2.1	2.1559.255.0	1	special bushing 34.60x39.130x34.65 (...) <=
2.1	2.1559.532.0	1	special bushing 34.60x39.130x36.65 => (...)
2.2	2.0399.213.0	2	screw m 12 p.1.25x61.5 (...) <=
2.2	2.0399.365.0	2	screw m 10 p.1.25x61.5 => (...)
3	0.065.1225.0	8	con.rod half bushing STANDARD - A = 28.75 -> 29.00 (...) <=
3	0.065.1225.7	8	con.rod half bushing - mm 0.25

CYLINDER - PISTON - CONNECTING ROD

Fig.	P/n	QTY	Name
			(...) <=
3	0.065.1225.8	8	con.rod half bushing - mm 0.50
			(...) <=
4	0.019.5453.0	4	con.rod half bushing STANDARD - A = 29.85 -> 30.10 => (...)
5	0.019.5454.0	4	con.rod half bushing STANDARD - A = 29.85 -> 30.10 => (...)



CAMSHAFT

Fig.	P/n	QTY	Name
------	-----	-----	------

Notes:
 [XA 85 -> ZKDCW40200TH10001]

1	0.065.1331.2	8	rod
2	0.013.9543.3	1	camshaft
2.2	0.065.1324.0/10	1	gear Z = 32
3	0.065.1330.0	8	tappets
4	2.1559.398.0	1	bushing 10.5x13x12
5	0.013.5017.0	1	gear z=58
6	0.065.1350.0	1	small disc
7	2.0132.207.2	4	screw m 10 p.1 x 25
8	2.1410.016.1	1	circlip 40
9	0.065.1352.0	1	shim
10	0.018.2233.0	2	shoulder ring
12	0.007.1177.3/20	1	gear z = 57 - WITH RED IDENTIFICATION STAMP
12.2	2.1559.185.0/10	1	bushing
13	0.007.1178.3/20	1	gear z = 57 - WITH YELLOW IDENTIFICATION STAMP
13.2	2.1559.185.0/10	1	bushing
14	0.007.1179.3/20	1	gear z = 57 - WITH GREEN IDENTIFICATION STAMP
14.2	2.1559.185.0/10	1	bushing
15	2.0312.205.2	2	screw
16	2.1480.014.1	2	washer 8
17	0.065.1353.0	1	small plate

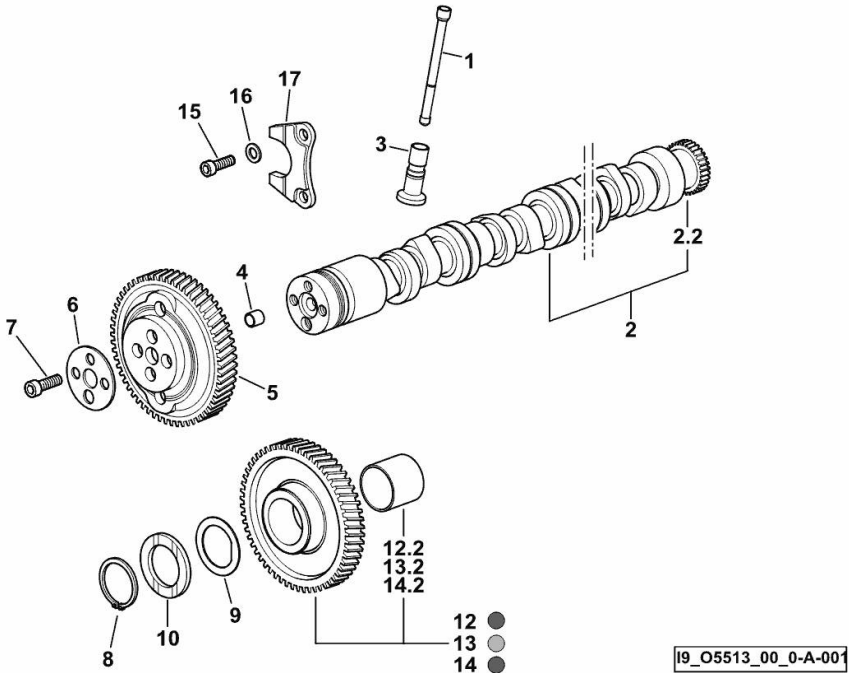

TIMING CASE

Fig.	P/n	QTY	Name
------	-----	-----	------

Notes:
 [XA 85 -> ZKDCW40200TH10001]

4	2.0432.009.7	1	stud bolt m 8 p.1.25 / p. 1 x 35
15	2.0432.003.7	1	stud bolt m 8 p.1.25 / p.1 x 20
16	2.0312.214.2	7	screw m 8 p.1.25 x 40
17	2.1480.014.1	15	washer 8
18	0.013.4981.0	1	guard
19	0.065.1150.0/30	1	gasket
20	2.1470.004.2	4	lock washer 8
21	2.1011.405.2	2	nut m 8 p.1
22	2.0312.208.2	8	screw m 8 p.1.25 x 25
23	2.1529.167.0	1	oil seal

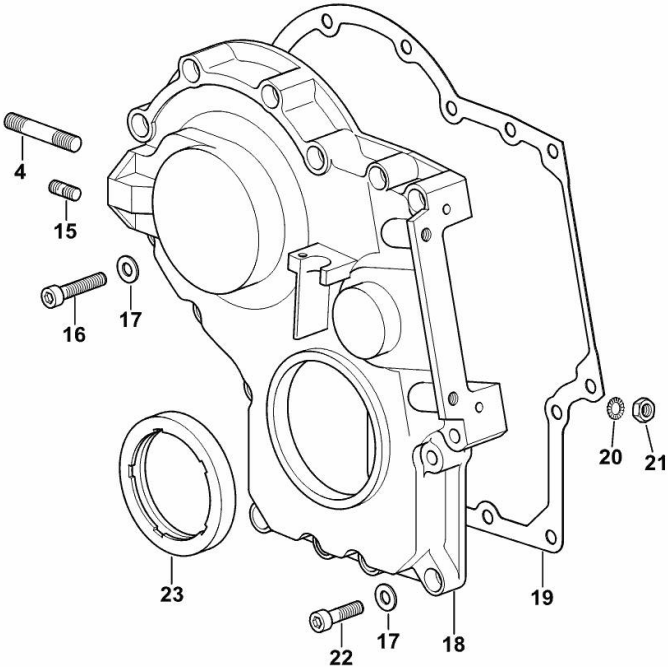

Thank you so much for reading.
Please click the “Buy Now!”
button below to download the
complete manual.



After you pay.

You can download the most
perfect and complete manual in
the world immediately.

Our support email:

ebooklibonline@outlook.com