

Section: B0 - ENGINE

CRANKCASE

Fig.	P/n	QTY	Name
------	-----	-----	------

Notes:

[XA-66 -> 3001]

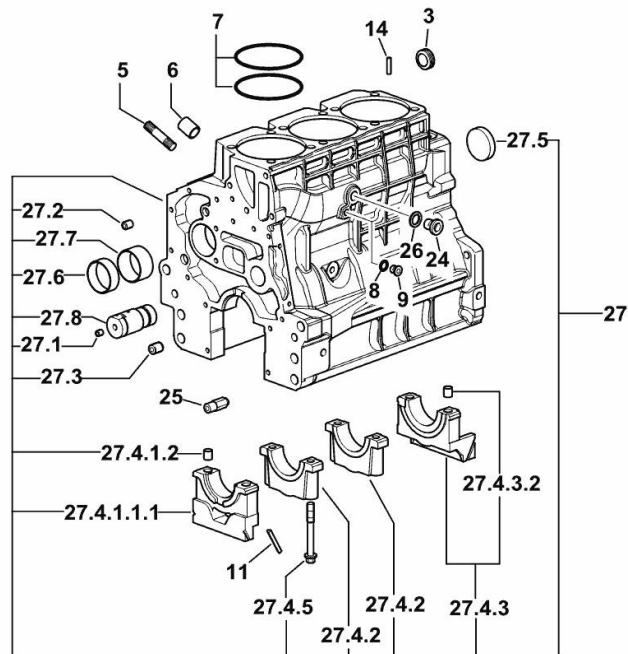

3	2.3199.312.2/20	1	plug m 35x1.5x9.5
5	2.0439.273.7	6	stud bolt m 8
6	2.1559.188.2	3	bush 11.4 x 14 x16
7	2.1539.259.0	6	special oil seal 107.62x2.62
8	2.1560.010.0	1	gasket 14.2 x 20
9	2.3199.292.0	1	plug 1/4" gas
11	0.066.1152.0/10	4	gasket
14	2.1549.154.2	3	bush 4.8x5.8x16
24	2.3120.101.0	1	plug m 18 p.1.5
25	0.013.4946.0/10	1	sprayer nozzle
26	2.1560.014.0	1	washer 18.2 x 24
27	0.015.2793.4/10	1	crankcase
27.1	2.3130.001.1	9	plug 1/8" gas
27.2	2.3130.002.1	2	plug 1/4" gas
27.3	2.3130.003.1	2	plug 3/8" gas
27.4.1.1.1	0.065.1112.7/10	1	support
27.4.1.2	2.1699.165.0	1	bush 12.3x15x16
27.4.2	0.065.1114.0/10	2	support
27.4.3	0.065.1116.3	1	support
27.4.3.2	2.1699.165.0	1	bush 12.3x15x16
27.4.5	0.065.1117.0	8	screw m 12 x 100
27.5	2.3179.012.0	1	plug 60
27.6	0.065.1140.0	3	special bushing 59X55X20
27.7	0.065.1141.0	1	special bushing 59X55X30
27.8	0.014.1340.0/10	1	pin mm 85

MONOBLOC ENGINE-GEARBOX CONNECTING FLANGE

Fig.	P/n	QTY	Name
------	-----	-----	------

Notes:

[XA-66 -> 3001]

1	0.007.7752.0/30	1	flange
2	2.0112.511.2	8	screw m 14 p.2 x 30
3	2.1651.912.0	2	cylindrical plug 12x28
4	2.1651.917.0	1	cylindrical plug 12x40
5	2.0432.257.7	1	stud bolt m 12 p.1.75 - 1.25 x 30
6	2.0439.250.7	1	stud bolt m 12 / m 10 x 30
7	0.011.9294.0/10	1	bush

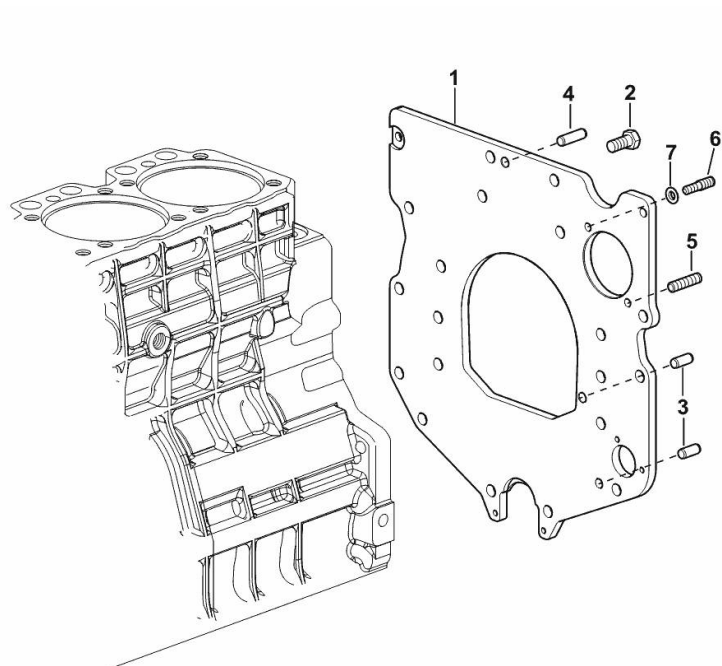

9_N1411_02_0-A-001

Section: B0 - ENGINE

CRANKSHAFT PULLEY

Fig.	P/n	QTY	Name
------	-----	-----	------

Notes:

[XA-66 -> 3001]

3	0.007.1457.0/30	1	pulley
5	0.085.1248.0/20	1	hub
6	2.0399.144.7/10	1	screw m 20 p.1.5x51
8	2.1720.006.0	1	key 4x6.5

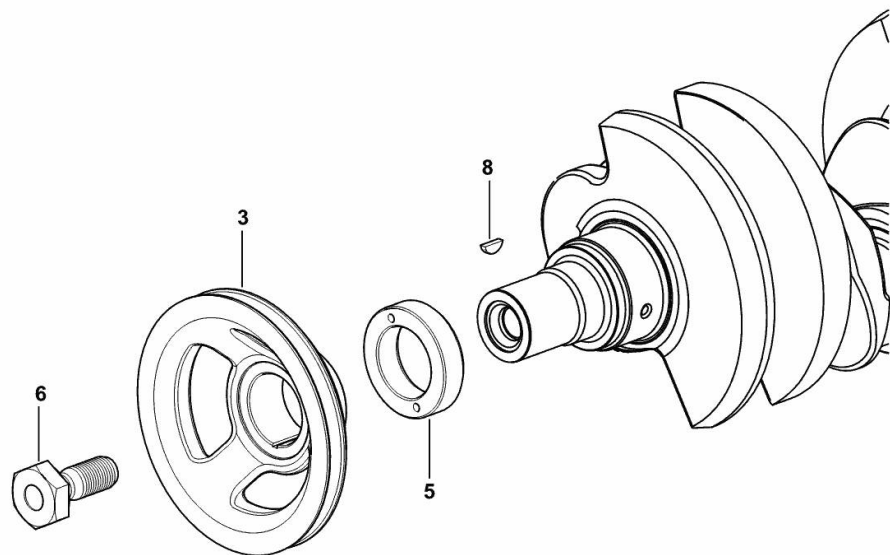

9_33312_02_0-A-001

Section: B0 - ENGINE

CRANKSHAFT PULLEY

Fig.	P/n	QTY	Name
------	-----	-----	------

Notes:

- FOR TRACTORS WITH AIR CONDITIONING [XA-66 -> 3001]

3	0.007.1458.0/40	1	pulley
5	0.085.1248.0/20	1	hub
6	2.0399.144.7/10	1	screw m 20 p.1.5x51
8	2.1720.006.0	1	key 4x6.5

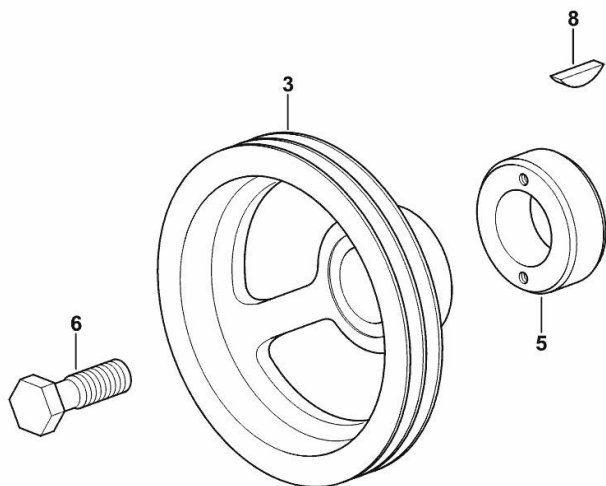

9_37512_06_0-A-001

PULSE WHEEL

Fig.	P/n	QTY	Name
------	-----	-----	------

Notes:

- FOR MODELS WITHOUT FRONT P.T.O. [XA-66 -> 3001]

1	0.011.3531.0	1	gear Z = 48
---	--------------	---	-------------

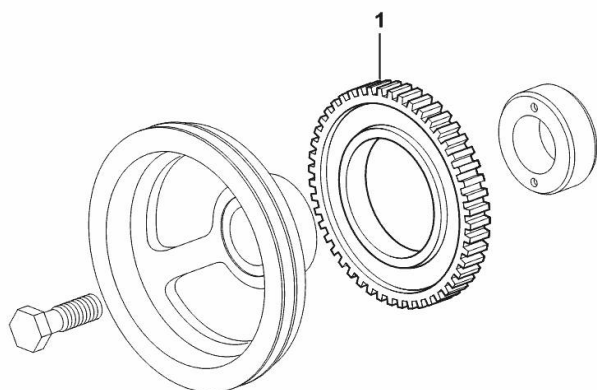

9_36812_05_0-A-001

ENGINE CRANKSHAFT PULLEY WITH RING-FEEDER RINGS

Fig.	P/n	QTY	Name
------	-----	-----	------

Notes:

- FOR MODELS EQUIPPED WITH FRONT P.T.O. [XA-66 -> 3001]

1	0.082.1244.0/10	1	pulley
2	0.011.3515.0/20	1	hub Z = 48
3	0.065.1256.0	2	ring 45x52
4	2.1579.865.0	1	spacer 45.2x51.8x10
5	2.0439.195.7	1	stud bolt m 20 p.1.5x80
6	2.1019.094.7	1	nut m 20 p.1.5

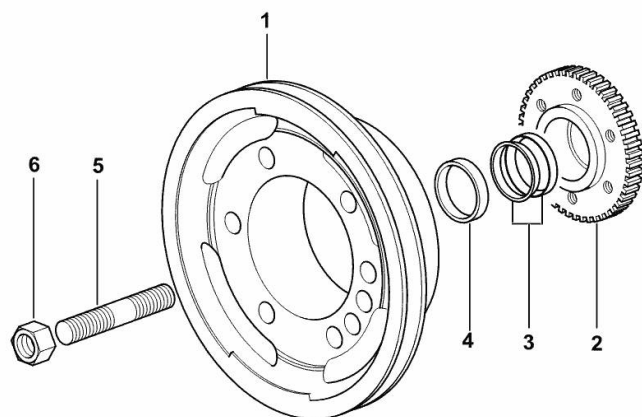

9_34512_07_0-A-001

ENGINE CRANKSHAFT PULLEY WITH RING-FEEDER RINGS

Fig.	P/n	QTY	Name
------	-----	-----	------

Notes:

- FOR TYPES WITH AIR CONDITIONING AND FRONT PTO [XA-66 -> 3001]

1	0.010.4274.0	1	pulley
2	0.011.3515.0/20	1	hub Z = 48
3	0.065.1256.0	2	ring 45x52
4	2.1579.865.0	1	spacer 45.2x51.8x10
5	2.0439.195.7	1	stud bolt m 20 p.1.5x80
6	2.1019.094.7	1	nut m 20 p.1.5
7	2.1589.137.0	3	shoulder ring 71x110x1
8	0.089.1253.0/10	1	spacer

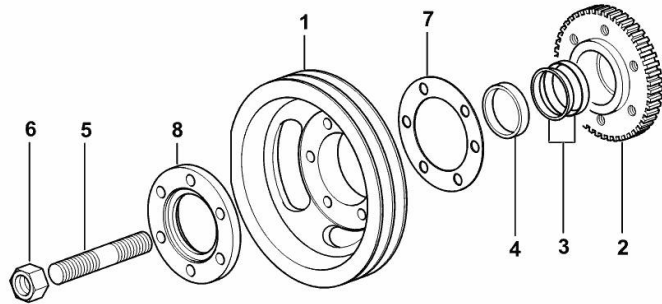

9_37512_03_0-A-001

COOLANT PUMP AND ALTERNATOR DRIVEBELT

Fig.	P/n	QTY	Name
------	-----	-----	------

Notes:

[XA-66 -> 3001]

1	2.4119.193.0	1	vee belt AV 10 x 1254 mm
---	--------------	---	--------------------------

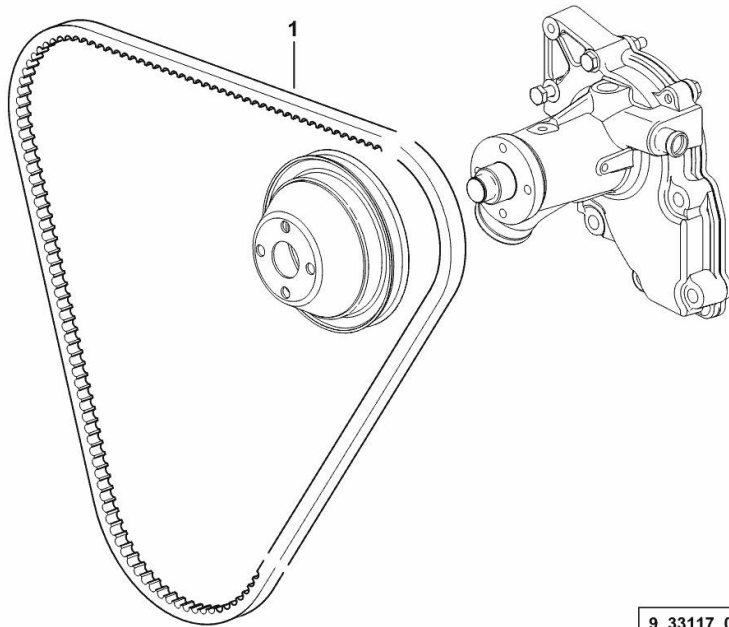

9_33117_09_0-A-001

COOLANT PUMP AND ALTERNATOR DRIVEBELT

Fig.	P/n	QTY	Name
------	-----	-----	------

Notes:

- FOR TRACTORS WITH AIR CONDITIONING [XA-66 -> 3001]

1	2.4119.138.0	2	belt AV 12.7x1380 mm
2	2.4119.134.0	1	belt AV 10x794 mm

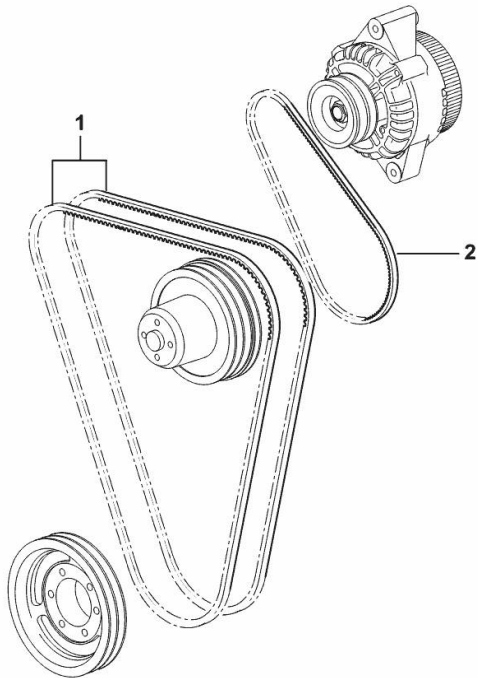

9_34517_11_0-A-001

Section: B0 - ENGINE

CRANKSHAFT

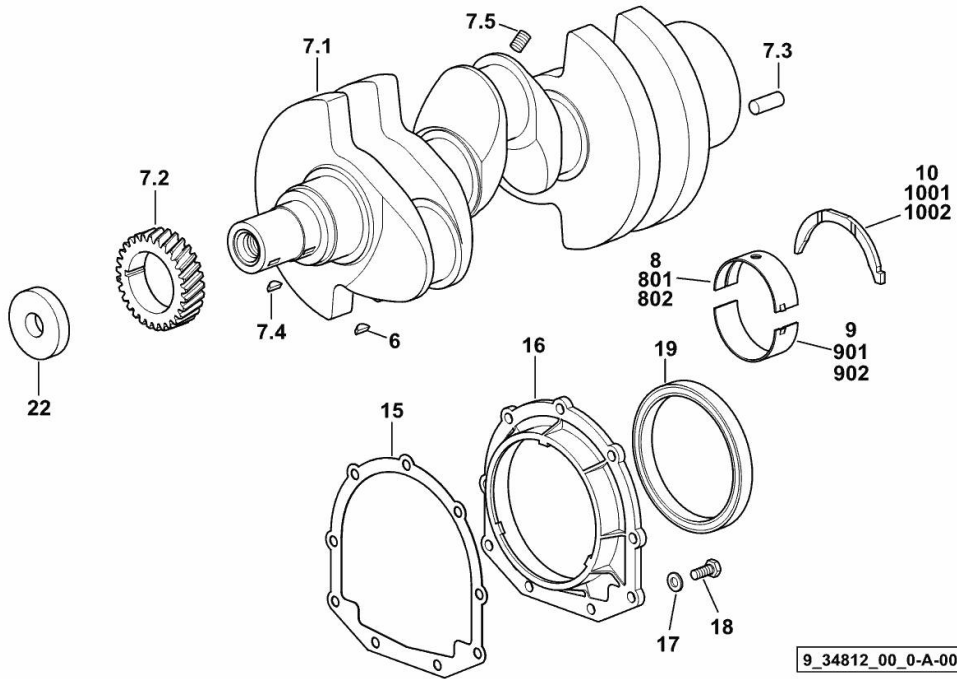

Fig.	P/n	QTY	Name
------	-----	-----	------

Notes:
[XA-66 -> 3001]

6	2.1720.006.0	1	key 4x6.5
7.1	0.007.1554.0/20	1	crankshaft
7.2	0.065.1323.0/30	1	gear Z = 29
7.3	2.1651.915.0	1	pin 12x35
7.4	2.1720.006.0	1	key 4x6.5
7.5	2.3130.001.1	3	plug 1/8" gas
8	0.065.1215.0/10	4	main half bushing STANDARD
9	0.065.1216.0/10	4	main half bushing STANDARD
10	0.065.1218.0	4	shim STANDARD
15	0.065.1254.0/20	1	gasket
16	0.007.1711.0/10	1	cover
17	2.1475.002.2	9	conical washer 8
18	2.0112.207.2	9	screw m 8 p 1.25 x 20
19	2.1529.073.0	1	special oil seal 110x130x13
22	2.1599.524.7	1	washer 21x60x12
801	0.065.1215.7		main half bushing - mm 0.25
802	0.065.1215.8		main half bushing - mm 0.50
901	0.065.1216.7		main half bushing - mm 0.25
902	0.065.1216.8		main half bushing - mm 0.50
1001	0.065.1218.7		shim + mm 0.10
1002	0.065.1218.8		shim + mm 0.15

9_34812_00_0-A-001

ENGINE FLYWHEEL

Fig.	P/n	QTY	Name
------	-----	-----	------

Notes:

[XA-66 -> 3001]

1	0.014.2774.3	1	flywheel
1.2	0.069.1242.0	1	crown wheel Z = 121
2	2.0139.036.2	6	screw m 12 p.1.25 x 35

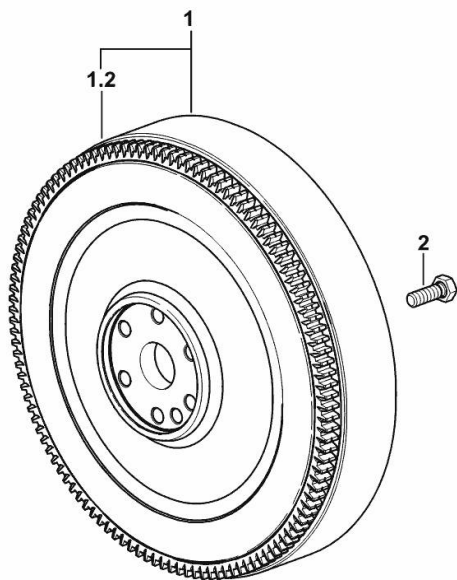

9_N1112_02_0-A-001

Thank you so much for reading.
Please click the “Buy Now!”
button below to download the
complete manual.



After you pay.

You can download the most
perfect and complete manual in
the world immediately.

Our support email:

ebooklibonline@outlook.com