

LIGHT ENGINE

Fig.	P/n	QTY	Name
-------------	------------	------------	-------------

Notes:
- EUROPE [XB 105 TB ->ZKDCR60200TH10001]

1	I6.IG601.00.0	1	engine ON ORDERING PLEASE ENGINE NO. REQUIRED
---	---------------	---	---

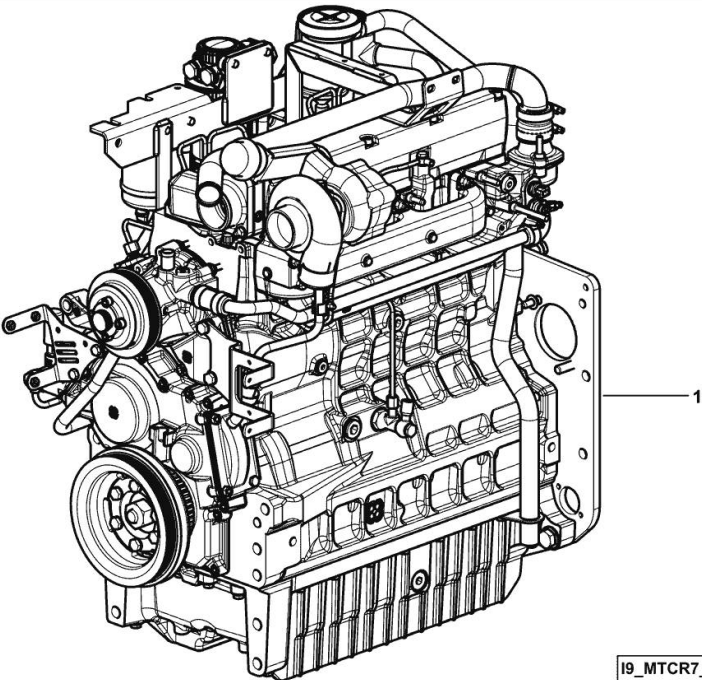

CRANKCASE

Fig.	P/n	QTY	Name
------	-----	-----	------

Notes:

[XB 105 TB ->ZKDCR60200TH10001]

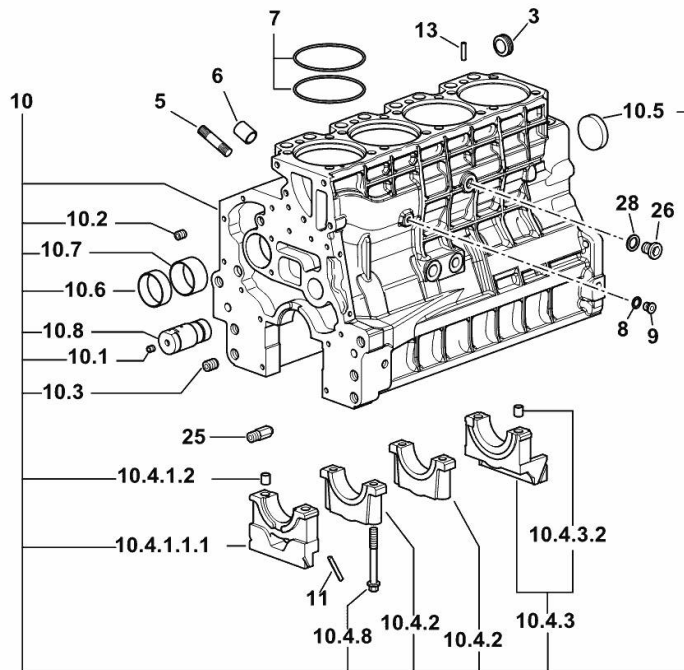

19_O1011_00_0-A-001

3	2.3199.312.2/20	1	plug m 35x1.5x9.5
5	2.0439.279.7	8	stud bolt m 8 p.1 x 25
6	2.1559.188.2	4	bush 11.4 x 14 x16
7	2.1539.259.0	8	special oil seal 107.62x2.62
8	2.1560.010.0	1	gasket 14.2 x 20
9	2.3199.292.0	1	plug 1/4" gas
10	0.014.9655.4/30	1	crankcase
10.1	2.3130.001.1	14	plug 1/8" gas
10.2	2.3130.002.1	4	plug 1/4" gas
10.3	2.3130.003.1	6	plug 3/8" gas
10.4.1.1.1	0.065.1112.7/10	1	support
10.4.1.2	2.1699.165.0	1	bush 12.3x15x16
10.4.2	0.065.1114.0/10	3	support
10.4.3	0.065.1116.3	1	support
10.4.3.2	2.1699.165.0	1	bush 12.3x15x16
10.4.8	0.065.1117.0	10	screw m 12 x 100
10.5	2.3179.012.0	1	plug 60
10.6	0.065.1140.0	4	special bushing 59X55X20
10.7	0.065.1141.0	1	special bushing 59X55X30
10.8	0.014.1340.0/10	1	pin mm 85
11	0.066.1152.0/10	4	gasket
13	2.1549.154.2	4	bush 4.8x5.8x16
25	0.013.4946.0/10	1	sprayer nozzle
26	2.3120.101.0	1	plug m 18 p.1.5
28	2.1560.014.0	1	washer 18.2 x 24

MONOBLOC ENGINE-GEARBOX CONNECTING FLANGE

Fig.	P/n	QTY	Name
------	-----	-----	------

Notes:

[XB 105 TB ->ZKDCR60200TH10001]

1	2.1475.005.2	2	washer 14
2	2.0112.524.2	2	screw m 14 p.2 x 75
3	2.0112.624.2	2	screw m 16 p.2 x 75
4	2.1475.006.2	2	spring washer 16
6	2.0439.250.7	1	stud bolt m 12 / m 10 x 30
7	0.011.9294.0/10	1	bush
25	0.019.1488.0	1	flange
26	2.0112.511.2	8	screw m 14 p.2 x 30
27	2.1651.912.0	2	cylindrical plug 12x28
28	2.1651.917.0	1	cylindrical plug 12x40
29	2.0432.257.7	1	stud bolt m 12 p.1.75 - 1.25 x 30

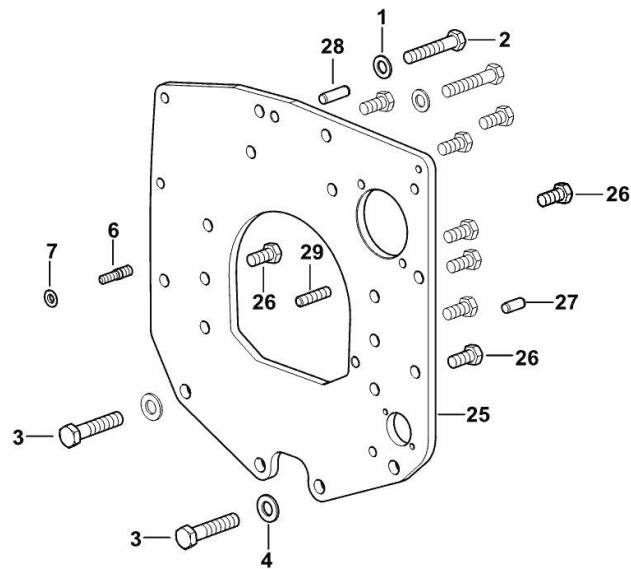

[9_K7411_01_0-A-001]

LOWER PLUG FOR CYLINDER BLOCKS

Fig.	P/n	QTY	Name
------	-----	-----	------

Notes:
[XB 105 TB ->ZKDCR60200TH10001]

1	2.3130.003.1	2	plug 3/8" gas
---	--------------	---	---------------

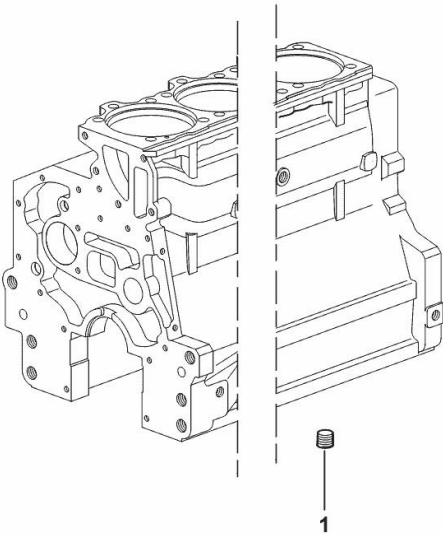

19_37511_06_0-A-001

SIDE PLUG FOR CYLINDER BLOCK

Fig.	P/n	QTY	Name
------	-----	-----	------

Notes:

[XB 105 TB ->ZKDCR60200TH10001]

22	2.1560.017.0	1	gasket 22.2 x 27
23	2.3120.002.4	1	plug m 22 x 1.5

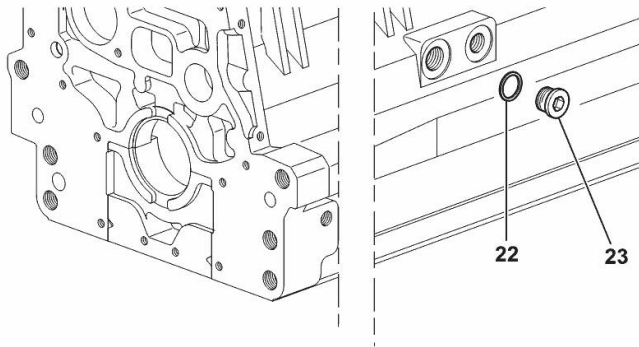

I9_33211_07_0-A-001

ENGINE OIL AND TURBO PRESSURE SWITCH UNION

Fig.	P/n	QTY	Name
------	-----	-----	------

Notes:

[XB 105 TB ->ZKDCR60200TH10001]

10	2.3339.574.2	1	pipe fitting
11	2.3249.014.2	1	pipe fitting m 12 p.1.5
12	2.1560.008.0	4	gasket 12.2 x 18
13	2.3335.005.2	1	pipe union m 12 p.1.5 x 24

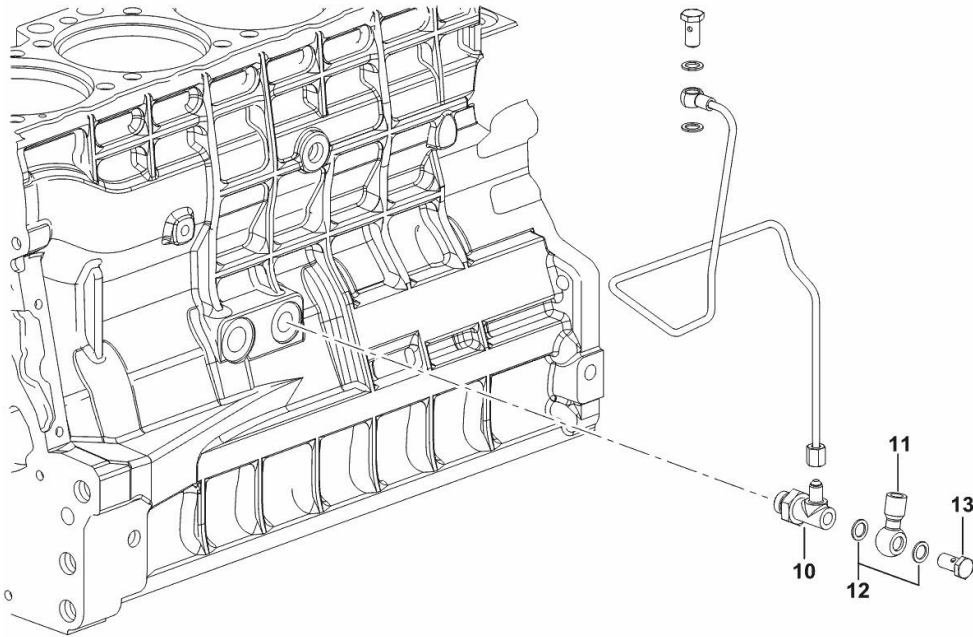

19_K1415_01_0-B-001

ENGINE FLYWHEEL

Fig.	P/n	QTY	Name
------	-----	-----	------

Notes:

[XB 105 TB ->ZKDCR60200TH10001]

1	0.019.2098.3	1	flywheel
1.2	0.065.1242.0	1	crown wheel Z = 123
2	0.255.2525.0/10	1	flange
3	2.0139.022.2	6	screw m 12 p.1.25x55

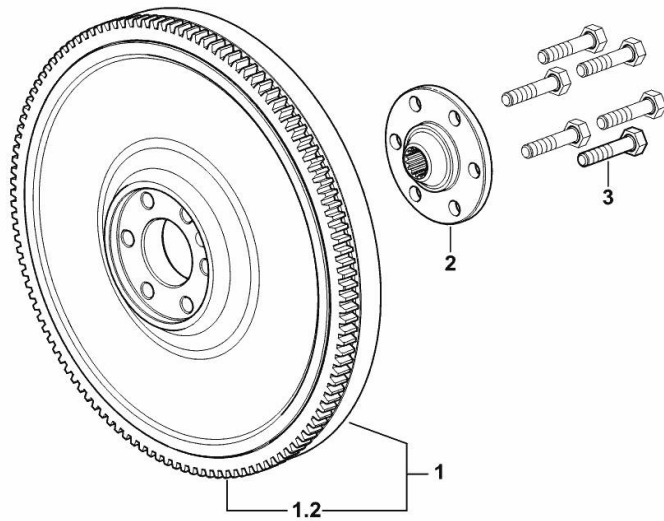

9_K7412_01_0-A-001

CRANKSHAFT

Fig.	P/n	QTY	Name
------	-----	-----	------

Notes:

[XB 105 TB ->ZKDCR60200TH10001]

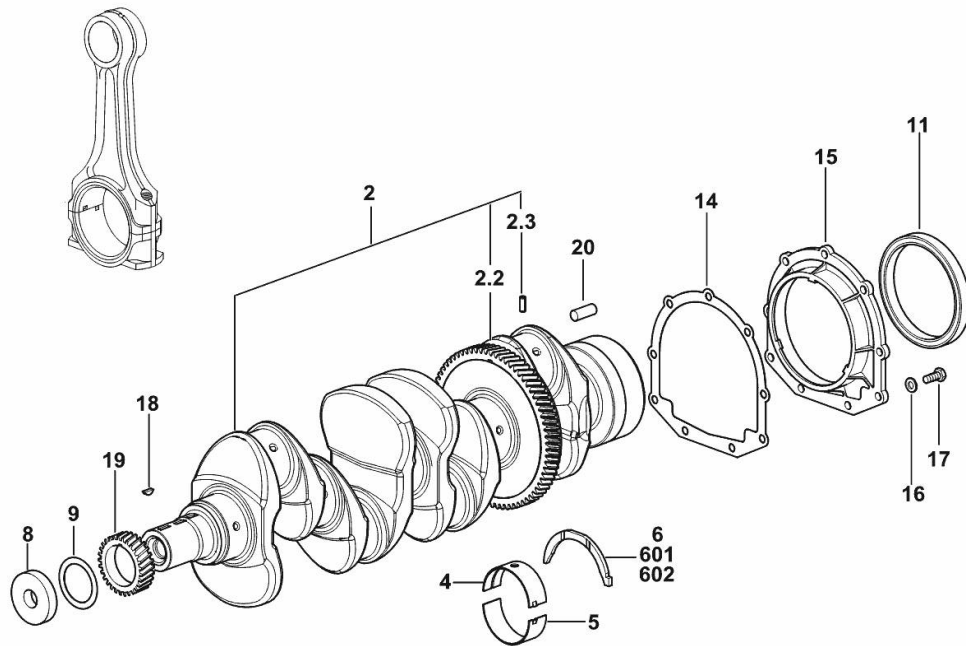

2	0.021.8246.3	1	crankshaft
2.2	0.065.1211.0/10	1	crown wheel
2.3	2.1630.608.0	1	pin 6x16
4	0.019.5455.0	5	main half bushing STANDARD
5	0.019.5456.0	5	main half bushing STANDARD
6	0.065.1218.0	4	shim STANDARD
8	2.1599.524.7	1	washer 21x60x12
9	2.1589.189.0	2	shoulder ring mm 1.00
11	2.1529.073.0	1	special oil seal 110x130x13
14	0.065.1254.0/20	1	gasket
15	0.007.1711.0/10	1	cover
16	2.1475.002.2	9	conical washer 8
17	2.0112.207.2	9	screw m 8 p 1.25 x 20
18	2.1720.006.0	1	key 4x6.5
19	0.065.1323.0/30	1	gear Z = 29
20	2.1651.915.0	1	pin 12x35
601	0.065.1218.7		shim + mm 0.10
602	0.065.1218.8		shim + mm 0.15

19_Q8012_00_0-A-002

ENGINE CRANKSHAFT PULLEY WITH RING-FEEDER RINGS

Fig.	P/n	QTY	Name
------	-----	-----	------

Notes:

[XB 105 TB ->ZKDCR60200TH10001]

1	0.015.6055.0	1	pulley
2	0.011.3515.0/20	1	hub Z = 48
3	0.065.1256.0	2	ring 45x52
4	2.1579.865.0	1	spacer 45.2x51.8x10
5	2.0439.195.7	1	stud bolt m 20 p.1.5x80
6	2.1019.094.7	1	nut m 20 p.1.5
7	2.0112.320.2	6	screw m 10 p.1.5 x 55
8	2.1470.006.2	6	lock washer 10

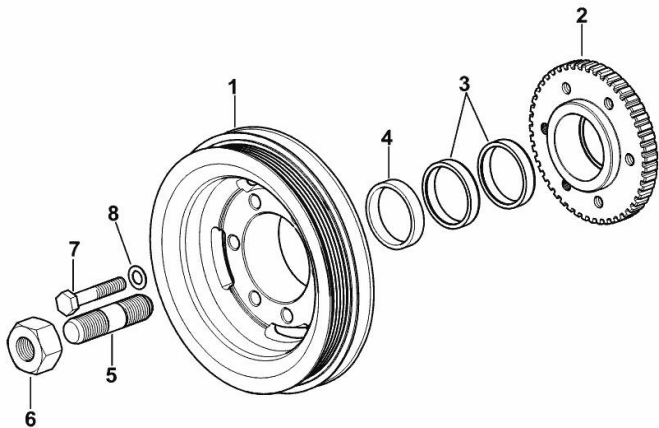

I9_O6312_03_0-A-001

COOLANT PUMP AND ALTERNATOR DRIVEBELT

Fig.	P/n	QTY	Name
------	-----	-----	------

Notes:
[XB 105 TB ->ZKDCR60200TH10001]

1	2.4119.188.0	1	belt PV-K5 17.4x1275 mm
---	--------------	---	-------------------------

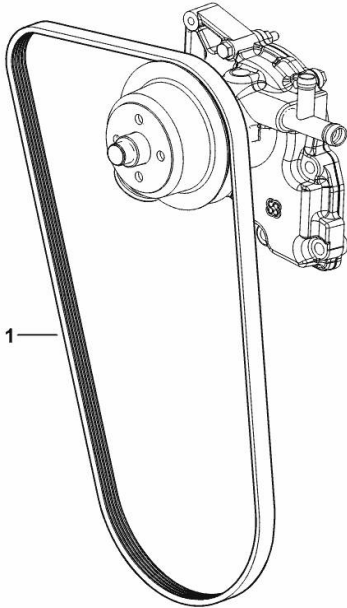

9_N1817_09_0-A-001

COUNTERWEIGHTS

Fig.	P/n	QTY	Name
------	-----	-----	------

Notes:

[XB 105 TB ->ZKDCR60200TH10001]

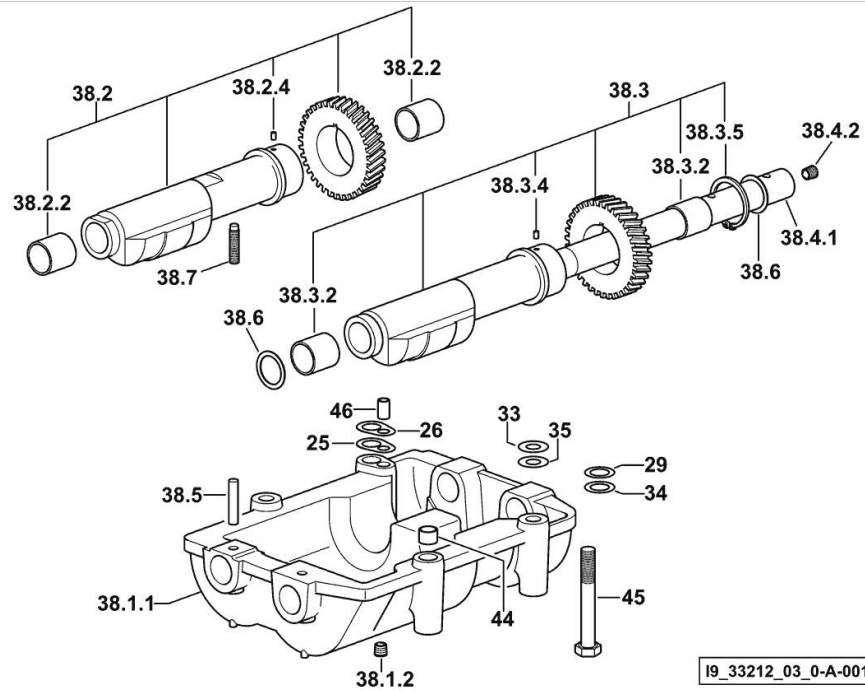

19_33212_03_0-A-001

25	2.1589.139.0	1	shoulder ring mm 0.3
26	2.1589.140.0	3	shoulder ring mm 0.1
29	2.1579.628.0	3	spacer 16.5x26x0.1
33	2.1579.629.0	6	spacer 12.5x26x0.1
34	2.1589.048.0	1	shoulder ring 16.5x26x0.3
35	2.1589.049.0	1	shoulder ring 12.5x26x0.3
38.1.1	0.086.1231.0/10	1	box
38.1.2	2.3130.001.1	4	plug 1/8" gas
38.2	0.086.1233.3/30	1	mass sx/lh/li
38.2.2	2.1559.115.0	2	special bushing 26x30x30
38.2.4	2.1651.302.0	1	roll pin 4x6
38.3	0.065.1233.3/30	1	mass dx/rh/re
38.3.2	2.1559.115.0	2	special bushing 26x30x30
38.3.4	2.1651.302.0	1	roll pin 4x6
38.3.5	2.1410.018.1	1	circlip 45
38.4.1	0.065.1234.0/10	1	shaft
38.4.2	2.3130.001.1	1	plug 1/8" gas
38.5	2.1631.717.0	2	roll pin 8 x 40
38.6	2.1589.185.0	4	shoulder ring 26.1x34x1
38.7	2.0522.212.7	1	screw m 8 p.1.25 x 30
44	2.1579.626.0	2	spacer 13.2x16x11
45	2.0139.028.2	4	screw m 12
46	2.1699.191.0	1	bush 7x10x16

CYLINDER - PISTON - CONNECTING ROD

Fig.	P/n	QTY	Name
------	-----	-----	------

Notes:

[XB 105 TB ->ZKDCR60200TH10001]

1	0.055.0065.A	4	cyl. piston assembly "A" - CLASS A
1	0.055.0065.B	4	cyl. piston assembly "B" - CLASS B
1.2	0.A12.2675.0	1	engine cylinder "A" - CLASS A
1.2	0.B12.2675.0	1	engine cylinder "B" - CLASS B
1.3	0.055.0060.A	1	complete piston "A" - CLASS A
1.3	0.055.0060.B	1	complete piston "B" - CLASS B
1.3.1	0.338.0052.6/20	1	piston ring set
1.3.2	2.1411.014.1	2	circlip 35
1.3.3	0.078.1236.0	1	piston pin Ø 18 / Ø 35 / L = mm 86
2	0.014.5175.3	4	engine connecting rod (...) <-
2	0.019.2226.3/10	4	engine connecting rod -> (...)
2.1	2.1559.255.0	1	special bushing 34.60x39.130x34.65 (...) <-
2.1	2.1559.532.0	1	special bushing 34.60x39.130x36.65 -> (...)
2.2	2.0399.213.0	2	screw m 12 p.1.25x61.5 (...) <-
2.2	2.0399.365.0	2	screw m 10 p.1.25x61.5 -> (...)
3	0.065.1225.0	8	con.rod half bushing STANDARD - A = 28.75 -> 29.00 (...) <-
3	0.065.1225.7	8	con.rod half bushing - mm 0.25 (...) <-
3	0.065.1225.8	8	con.rod half bushing - mm 0.50 (...) <-
4	0.019.5453.0	4	con.rod half bushing STANDARD - A = 29.85 -> 30.10 -> (...)
5	0.019.5454.0	4	con.rod half bushing STANDARD - A = 29.85 -> 30.10 -> (...)

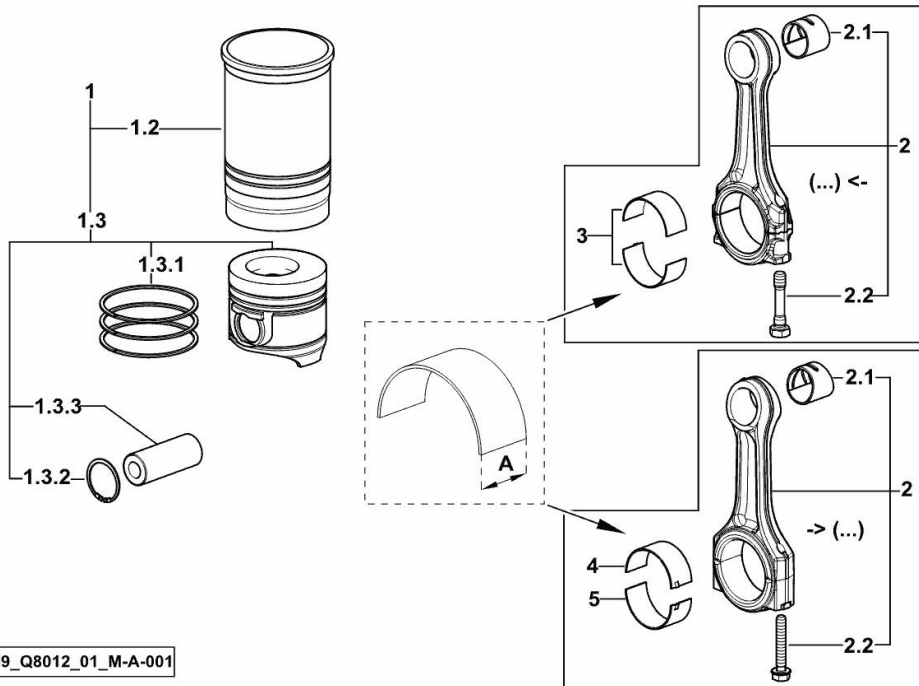

19_Q8012_01_M-A-001

CAMSHAFT

Fig.	P/n	QTY	Name
------	-----	-----	------

Notes:

[XB 105 TB ->ZKDCR60200TH10001]

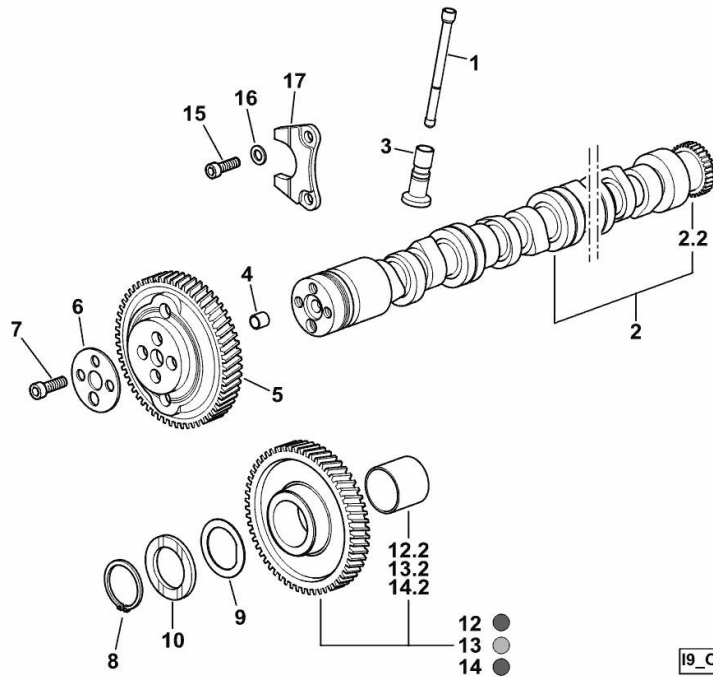

1	0.065.1331.2	8	rod
2	0.013.9543.3	1	camshaft
2.2	0.065.1324.0/10	1	gear Z = 32
3	0.065.1330.0	8	tappets
4	2.1559.398.0	1	bushing 10.5x13x12
5	0.013.5017.0	1	gear z=58
6	0.065.1350.0	1	small disc
7	2.0132.207.2	4	screw m 10 p.1 x 25
8	2.1410.016.1	1	circlip 40
9	0.065.1352.0	1	shim
10	0.018.2233.0	2	shoulder ring
12	0.007.1177.3/20	1	gear z = 57 - WITH RED IDENTIFICATION STAMP
12.2	2.1559.185.0/10	1	bushing
13	0.007.1178.3/20	1	gear z = 57 - WITH YELLOW IDENTIFICATION STAMP
13.2	2.1559.185.0/10	1	bushing
14	0.007.1179.3/20	1	gear z = 57 - WITH GREEN IDENTIFICATION STAMP
14.2	2.1559.185.0/10	1	bushing
15	2.0312.205.2	2	screw
16	2.1480.014.1	2	washer 8
17	0.065.1353.0	1	small plate

TIMING CASE

Fig.	P/n	QTY	Name
------	-----	-----	------

Notes:

[XB 105 TB ->ZKDCR60200TH10001]

4	2.0432.009.7	1	stud bolt m 8 p.1.25 / p. 1 x 35
15	2.0432.003.7	1	stud bolt m 8 p.1.25 / p.1 x 20
16	2.0312.214.2	7	screw m 8 p.1.25 x 40
17	2.1480.014.1	15	washer 8
18	0.013.4981.0	1	guard
19	0.065.1150.0/30	1	gasket
20	2.1470.004.2	4	lock washer 8
21	2.1011.405.2	2	nut m 8 p.1
22	2.0312.208.2	8	screw m 8 p.1.25 x 25
23	2.1529.167.0	1	oil seal

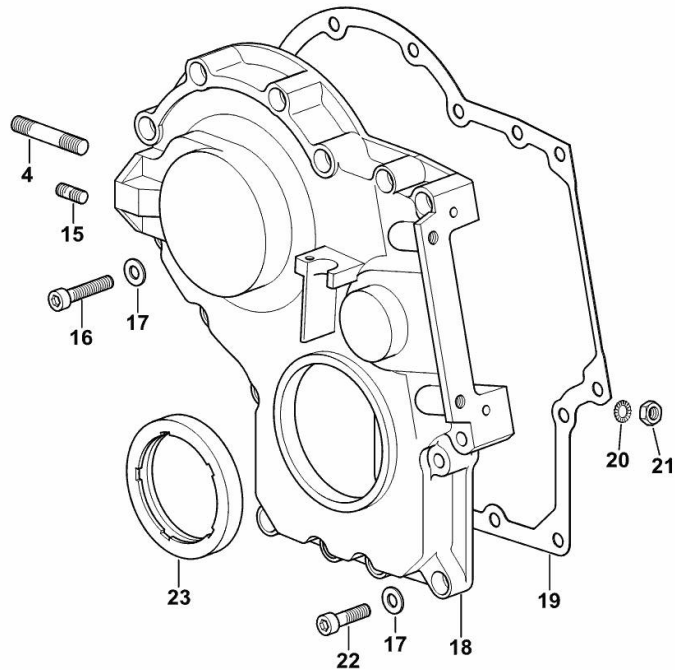

TIMING COVER FIXING

Fig.	P/n	QTY	Name
-------------	------------	------------	-------------

Notes:

[XB 105 TB ->ZKDCR60200TH10001]

4	0.016.7791.0	2	small column
5	2.0112.317.2	2	screw m 10 p.1.5 x 45
6	2.1470.006.2	2	lock washer 10

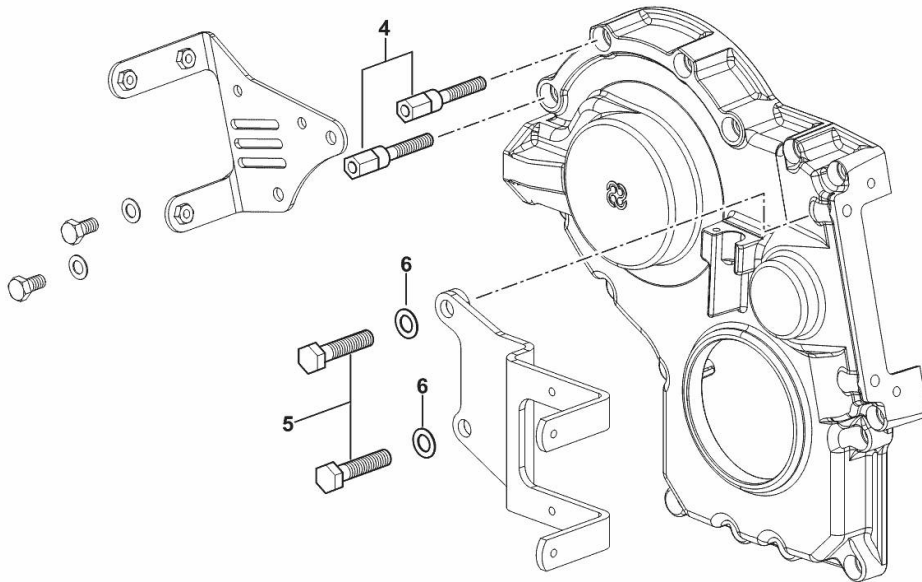

I9_07411_01_0-B-001

CASING COVER

Fig.	P/n	QTY	Name
-------------	------------	------------	-------------

Notes:

[XB 105 TB ->ZKDCR60200TH10001]

30	0.065.1152.0	1	gasket
31	0.007.0623.2	1	cover
32	2.0112.205.2	2	screw m 8 p.1.25 x 16
33	2.0432.003.7	2	stud bolt m 8 p.1.25 / p.1 x 20

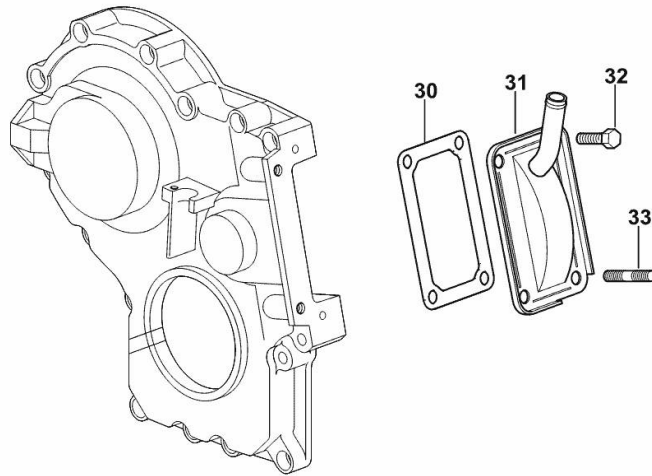

Thank you so much for reading.
Please click the “Buy Now!”
button below to download the
complete manual.



After you pay.

You can download the most
perfect and complete manual in
the world immediately.

Our support email:

ebooklibonline@outlook.com