

CRANKCASE

Fig.	P/n	QTY	Name
------	-----	-----	------

Notes:
[XF 55 SPIRIT DT]

3	2.3199.312.2/20	1	plug m 35x1.5x9.5
5	2.0439.279.7	6	stud bolt m 8 p.1 x 25
6	2.1559.188.2	3	bush 11.4 x 14 x16
7	2.1539.259.0	6	special oil seal 107.62x2.62
8	2.1560.010.0	1	gasket 14.2 x 20
9	2.3199.292.0	1	plug 1/4" gas
10	0.014.9911.4/30	1	crankcase
10.1	2.3130.001.1	12	plug 1/8" gas
10.2	2.3130.002.1	4	plug 1/4" gas
10.3	2.3130.003.1	2	plug 3/8" gas
10.4.1.1.1	0.065.1112.7/10	1	support
10.4.1.2	2.1699.165.0	1	bush 12.3x15x16
10.4.2	0.065.1114.0/10	2	support
10.4.3.1.1	0.065.1116.7/10	1	support
10.4.3.2	2.1699.165.0	1	bush 12.3x15x16
10.4.8	0.065.1117.0	8	screw m 12 x 100
10.5	2.3179.012.0	1	plug 60
10.6	0.065.1140.0	3	special bushing 59X55X20
10.7	0.065.1141.0	1	special bushing 59X55X30
10.8	0.014.1340.0/10	1	pin mm 85
11	0.066.1152.0/10	4	gasket
14	2.1549.154.2	3	bush 4.8x5.8x16
20	2.1470.004.2	4	lock washer 8
24	2.3120.101.0	1	plug m 18 p.1.5
25	0.013.4946.0/10	1	sprayer nozzle
26	2.1560.014.0	1	washer 18.2 x 24

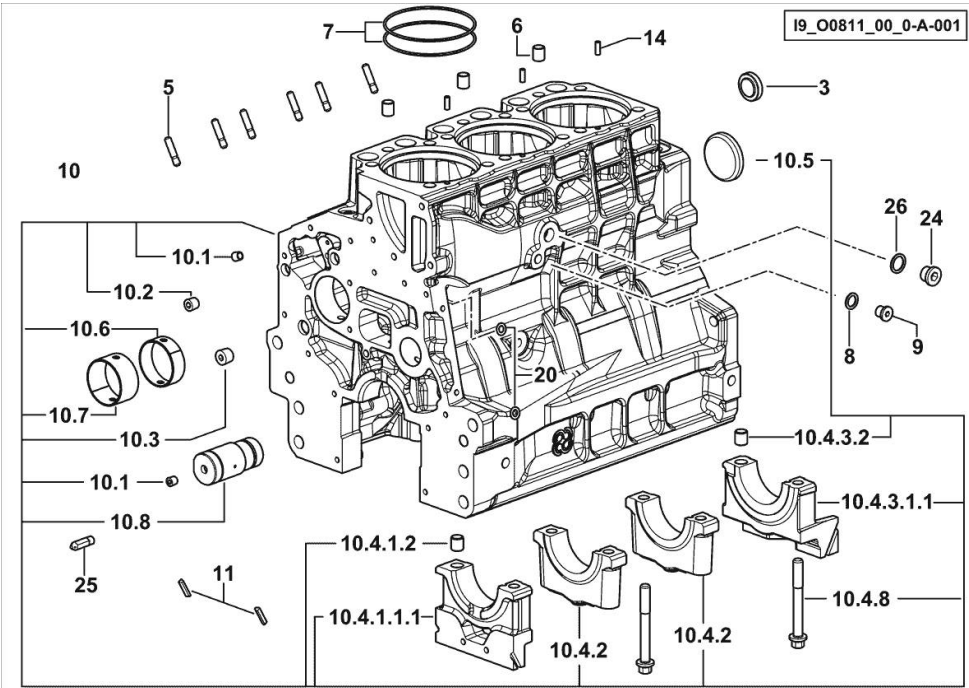

MONOBLOC ENGINE-GEARBOX CONNECTING FLANGE

Fig.	P/n	QTY	Name
------	-----	-----	------

Notes:
[XF 55 SPIRIT DT]

1	0.015.8814.0	1	flange
2	2.0112.511.2	8	screw m 14 p.2 x 30
3	2.0432.255.7	2	stud bolt m 12 p.1.75-1.25x25
4	2.1651.912.0	4	cylindrical plug 12x28
5	2.0512.404.7	2	screw

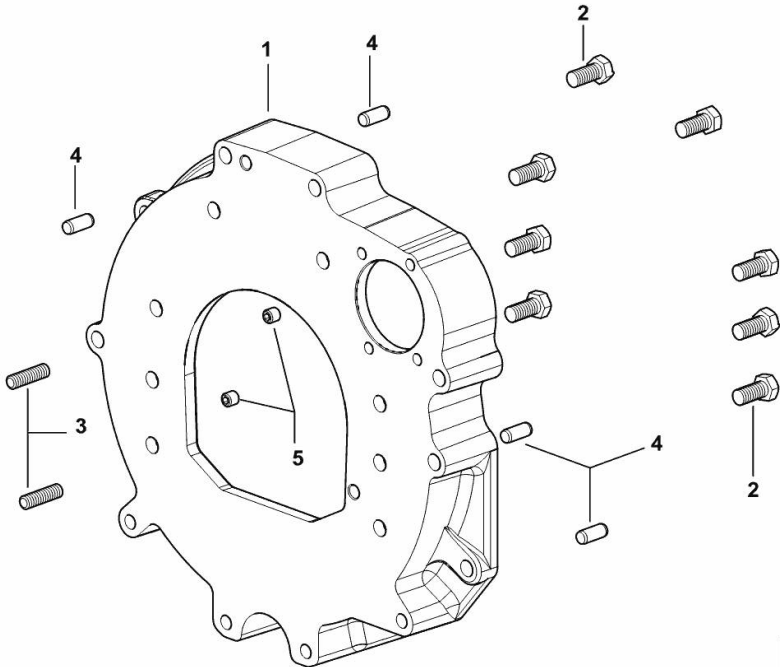

CRANKSHAFT

Fig.	P/n	QTY	Name
------	-----	-----	------

Notes:
[XF 55 SPIRIT DT]

6	2.1720.006.0	1	key 4x6.5
7	0.019.2255.0/30	1	crankshaft
8	0.019.5455.0	4	main half bushing STANDARD
9	0.019.5456.0	4	main half bushing STANDARD
10	0.065.1218.0	4	shim STANDARD
15	0.065.1254.0/20	1	gasket
16	0.007.1711.0/10	1	cover
17	2.1475.002.2	9	conical washer 8
18	2.0112.207.2	9	screw m 8 p 1.25 x 20
19	2.1529.073.0	1	special oil seal 110x130x13
22	2.1599.524.7	1	washer 21x60x12
23	0.065.1323.0/30	1	gear Z = 29
24	2.1651.915.0	1	pin 12x35
1001	0.065.1218.7		shim + mm 0.10
1002	0.065.1218.8		shim + mm 0.15

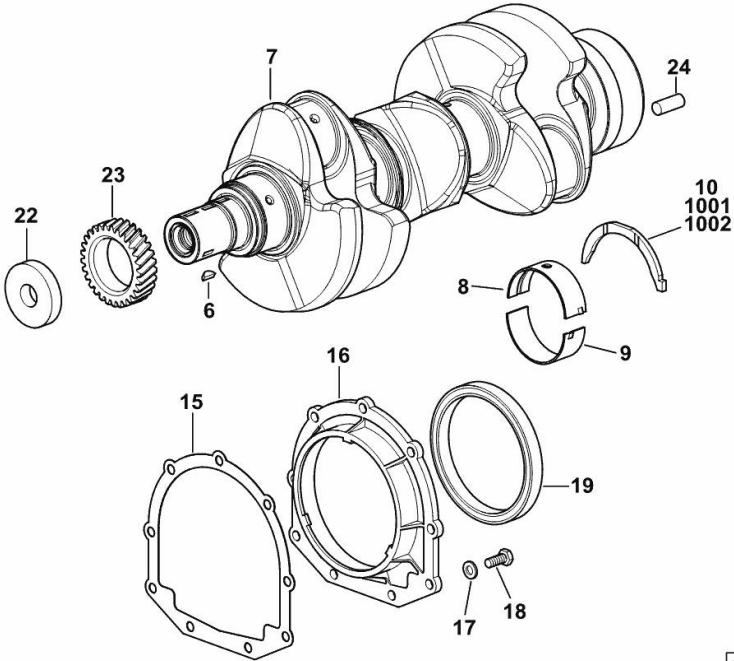

19_O8312_00_0-A-002

CRANKSHAFT PULLEY

Fig.	P/n	QTY	Name
------	-----	-----	------

Notes:
[XF 55 SPIRIT DT]

3	0.007.1457.0/30	1	pulley
5	0.085.1248.0/20	1	hub
6	2.0399.144.7/10	1	screw m 20 p.1.5x51
8	2.1720.006.0	1	key 4x6.5

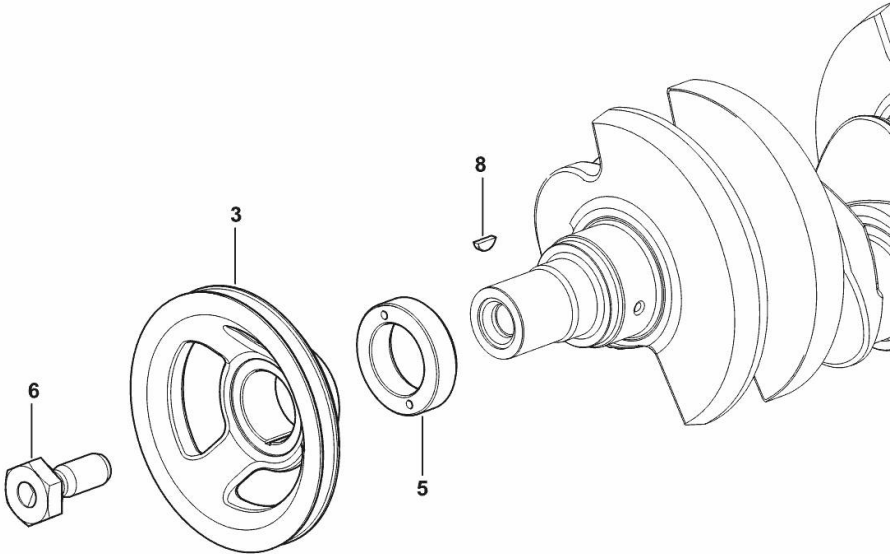

19_33312_02_0-A-001

COOLANT PUMP AND ALTERNATOR DRIVEBELT

Fig.	P/n	QTY	Name
------	-----	-----	------

Notes:
[XF 55 SPIRIT DT]

3	2.4119.198.0	1	vee belt AV 10.7x1240 mm
---	--------------	---	--------------------------

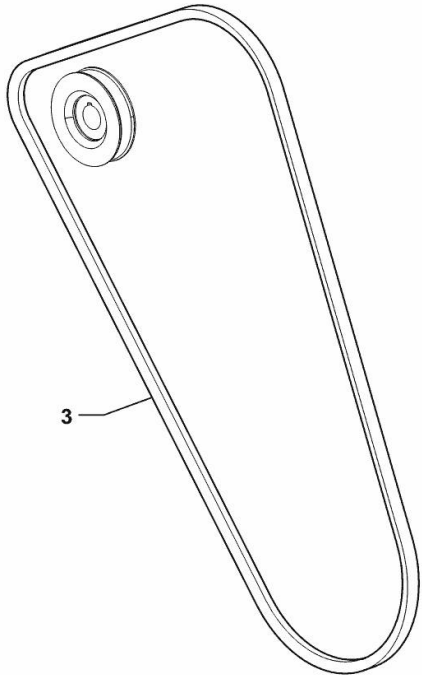

19_O2519_11_0-A-001

ENGINE FLYWHEEL

Fig.	P/n	QTY	Name
------	-----	-----	------

Notes:
[XF 55 SPIRIT DT]

1	0.007.1617.3/30	1	flywheel
1.2	0.069.1242.0	1	crown wheel Z = 121
2	2.0119.174.0/10	6	screw m 12 p.1.25x45
3	2.2041.008.9	1	ball bearing 20x47x14

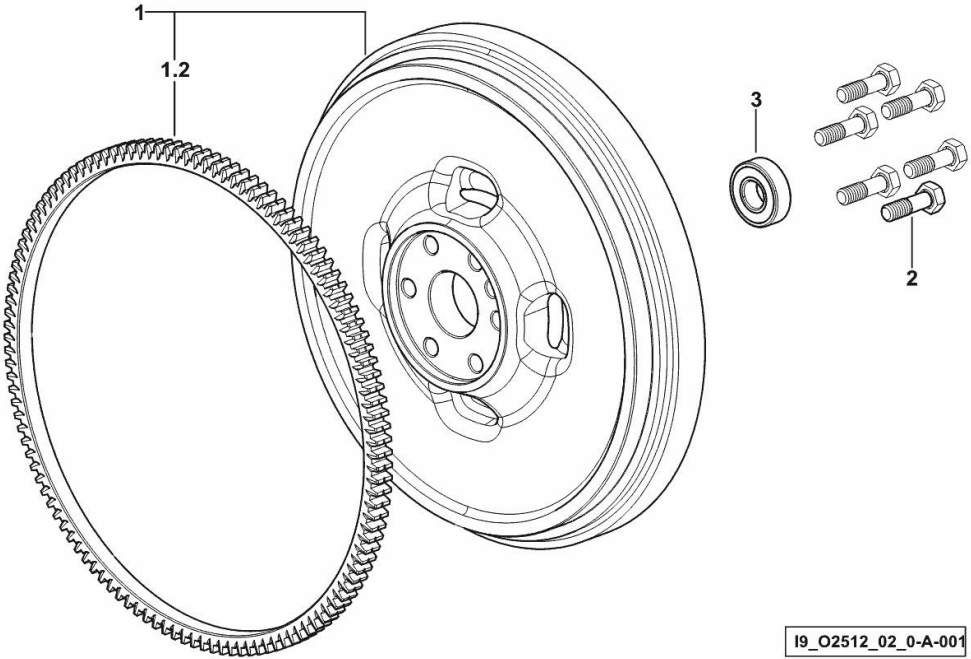

19_O2512_02_0-A-001

CYLINDER - PISTON - CONNECTING ROD

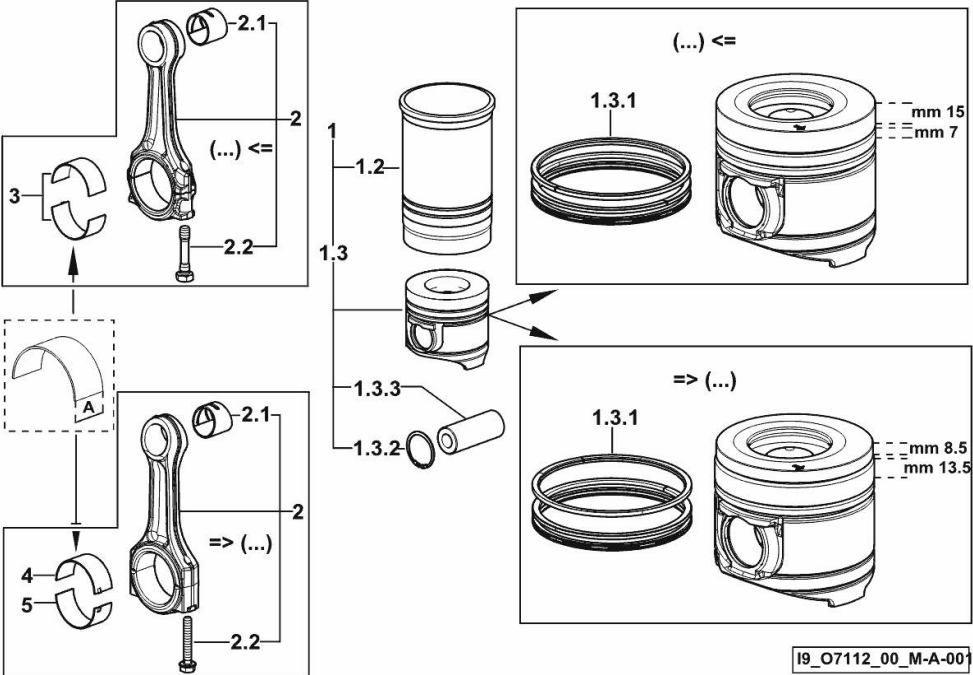
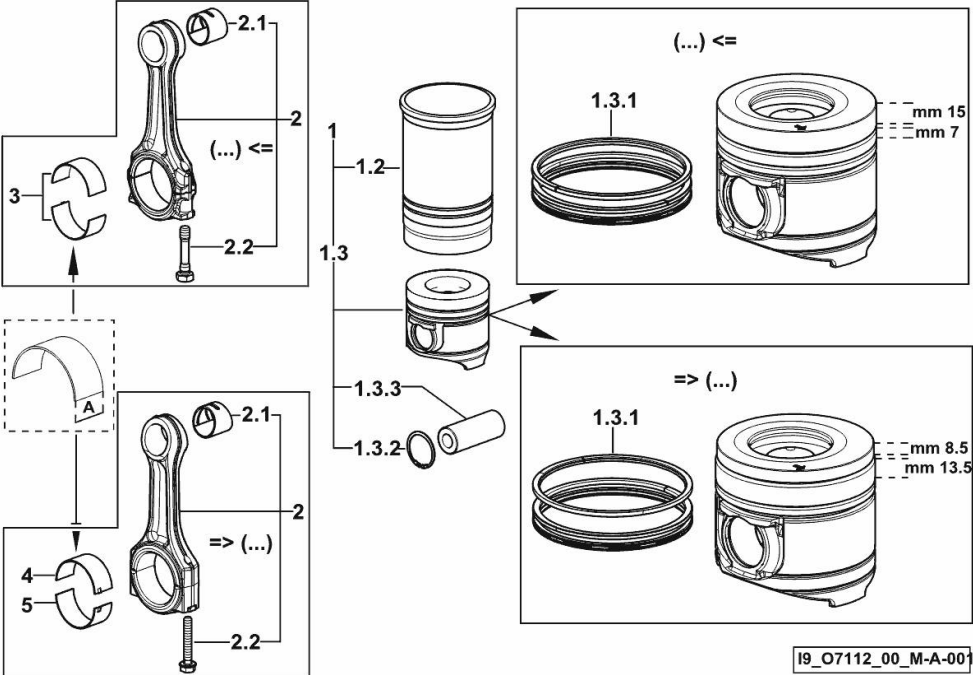

Fig.	P/n	QTY	Name
Notes:			
[XF 55 SPIRIT DT]			
1	0.O68.0065.A	3	cyl. piston assembly "A" (...) <= - CLASS A
1	0.O68.0065.B	3	cyl. piston assembly "B" (...) <= - CLASS B
1	0.Q92.0065.A	3	cyl. piston assembly "A" => (...) - CLASS A
1	0.Q92.0065.B	3	cyl. piston assembly "B" => (...) - CLASS B
1.2	0.A12.2675.0	3	engine cylinder "A" - CLASS A
1.2	0.B12.2675.0	3	engine cylinder "B" - CLASS B
1.3	0.O68.0060.A	1	complete piston "A" (...) <= - CLASS A
1.3	0.O68.0060.B	1	complete piston "B" (...) <= - CLASS B
1.3	0.Q92.0060.A	1	complete piston "A" => (...) - CLASS A
1.3	0.Q92.0060.B	1	complete piston "B" => (...) - CLASS B
1.3.1	0.081.0090.6/10	1	piston ring set (...) <=
1.3.1	0.Q92.0052.6	1	piston ring set => (...)
1.3.2	2.1411.014.1	2	circlip 35
1.3.3	0.078.1236.0	1	piston pin Ø 18 / Ø 35 / L = mm 86
2	0.014.5175.3	3	engine connecting rod (...) <=
2	0.019.2226.3/10	3	engine connecting rod => (...)
2.1	2.1559.255.0	1	special bushing 34.60x39.130x34.65 (...) <=
2.1	2.1559.532.0	1	special bushing 34.60x39.130x36.65 => (...)
2.2	2.0399.213.0	2	screw m 12 p.1.25x61.5 (...) <=
2.2	2.0399.365.0	2	screw m 10 p.1.25x61.5 => (...)
3	0.065.1225.0	6	con.rod half bushing STANDARD - A = 28.75 -> 29.00 (...) <=
3	0.065.1225.7	6	con.rod half bushing - mm 0.25

CYLINDER - PISTON - CONNECTING ROD

Fig.	P/n	QTY	Name
			(...) <=
3	0.065.1225.8	6	con.rod half bushing - mm 0.50
			(...) <=
4	0.019.5453.0	3	con.rod half bushing STANDARD - A = 29.85 -> 30.10 => (...)
5	0.019.5454.0	3	con.rod half bushing STANDARD - A = 29.85 -> 30.10 => (...)



TIMING CASE

Fig.	P/n	QTY	Name
------	-----	-----	------

Notes:
[XF 55 SPIRIT DT]

15	2.0432.003.7	2	stud bolt m 8 p.1.25 / p.1 x 20
16	2.0312.214.2	7	screw m 8 p.1.25 x 40
17	2.1480.014.1	15	washer 8
18	0.013.4981.0	1	guard
19	0.065.1150.0/30	1	gasket
20	2.1470.004.2	4	lock washer 8
21	2.1011.405.2	2	nut m 8 p.1
22	2.0312.208.2	8	screw m 8 p.1.25 x 25
23	2.1529.167.0	1	oil seal

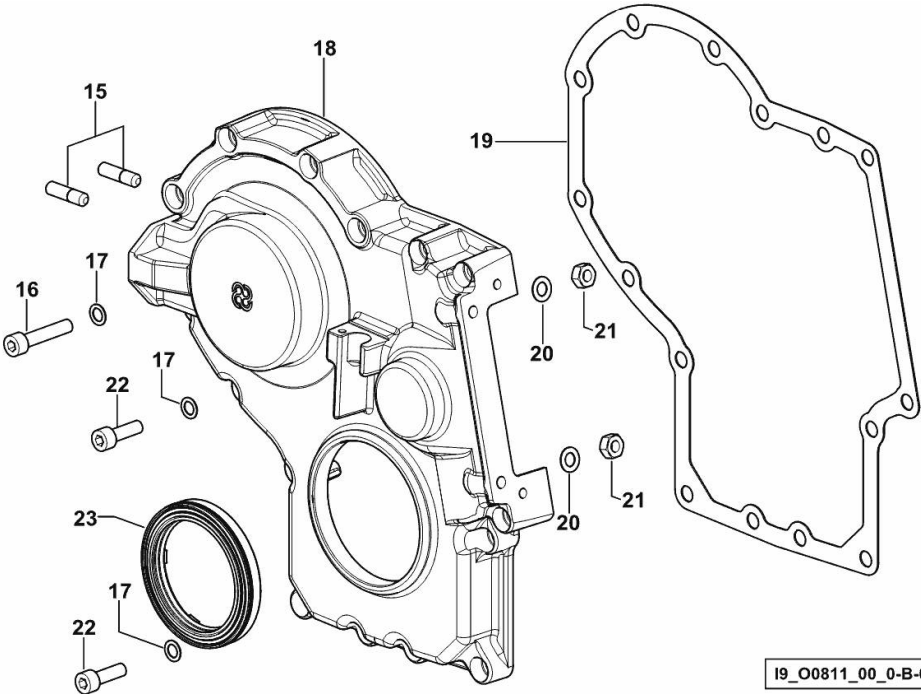

19_O0811_00_0-B-001

GUARD PLATE

Fig.	P/n	QTY	Name
------	-----	-----	------

Notes:
[XF 55 SPIRIT DT]

1	0.007.1262.3/50	1	guard
2	0.012.0707.0	1	small column m 8 p.1.25 / L = mm 60
3	0.012.0708.0	2	small column m 8 p.1.25 / L = mm 50
5	2.1310.004.2	3	flat washer 8.4x17
7	2.0112.203.2	3	screw m 8 p.1.25 x 12

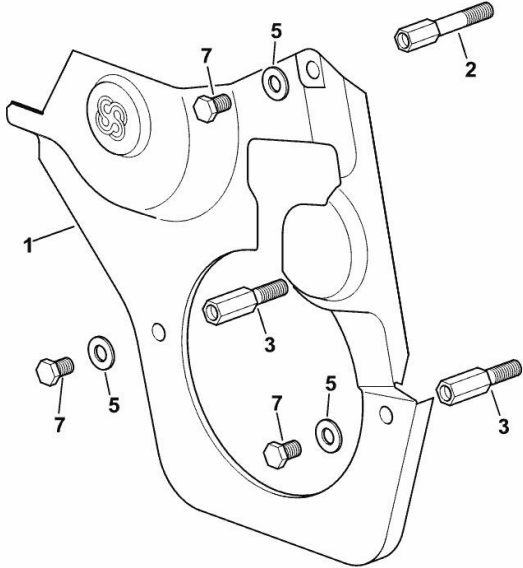

19_33011_02_0-A-001

CAMSHAFT

Fig.	P/n	QTY	Name
------	-----	-----	------

Notes:
[XF 55 SPIRIT DT]

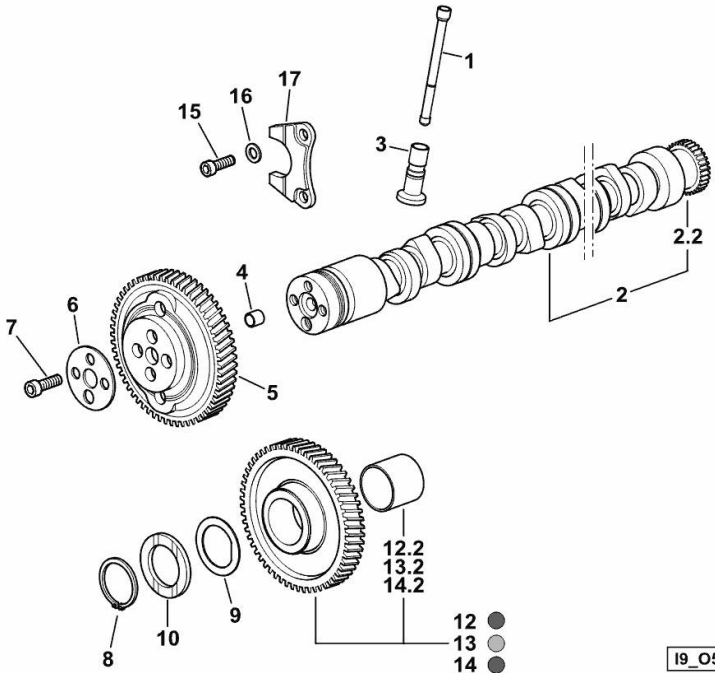

1	0.065.1331.2	6	rod
2	0.016.3967.3	1	camshaft
2.2	0.065.1324.0/10	1	gear Z = 32
3	0.065.1330.0	6	tappets
4	2.1559.398.0	1	bushing 10.5x13x12
5	0.013.5017.0	1	gear z=58
6	0.065.1350.0	1	small disc
7	2.0132.207.2	4	screw m 10 p.1 x 25
8	2.1410.016.1	1	circlip 40
9	0.065.1352.0	1	shim
10	0.018.2233.0	2	shoulder ring
12	0.007.1177.3/20	1	gear z = 57 - WITH RED IDENTIFICATION STAMP
12.2	2.1559.185.0/10	1	bushing
13	0.007.1178.3/20	1	gear z = 57 - WITH YELLOW IDENTIFICATION STAMP
13.2	2.1559.185.0/10	1	bushing
14	0.007.1179.3/20	1	gear z = 57 - WITH GREEN IDENTIFICATION STAMP
14.2	2.1559.185.0/10	1	bushing
15	2.0312.205.2	2	screw
16	2.1480.014.1	2	washer 8
17	0.065.1353.0	1	small plate

Section: B0 - ENGINE
CYLINDER HEAD

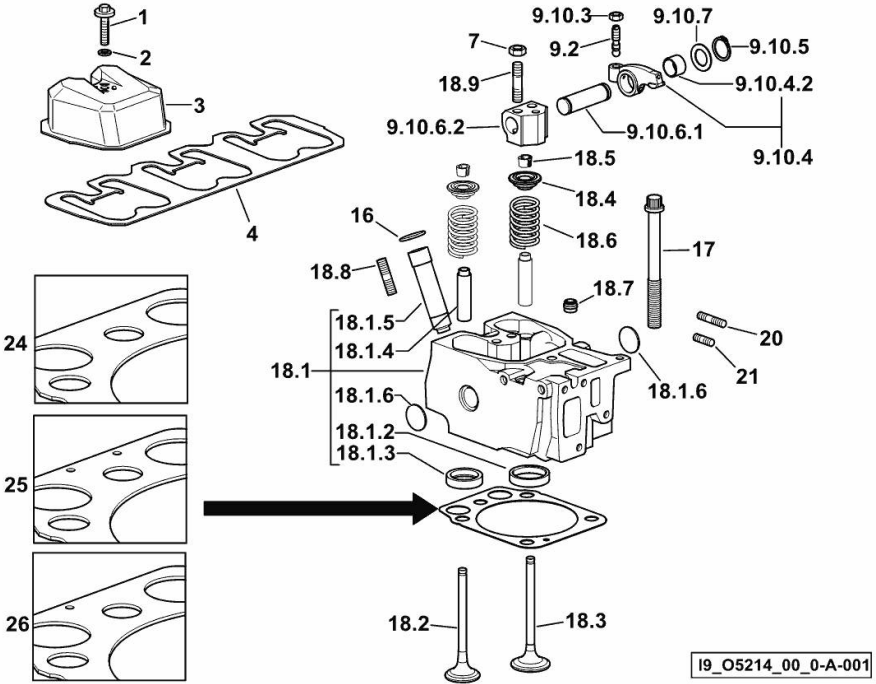

Fig.	P/n	QTY	Name
Notes:			
[XF 55 SPIRIT DT]			
1	2.0399.288.2/10	3	screw m 8x36x46
2	2.1532.018.0	3	oil seal 9.19 x 2.62
3	0.007.1139.0/10	3	small cap
4	0.069.1450.0/30	1	tappet gasket
7	2.1011.421.2	6	nut m 10 p.1.25
9.2	0.021.1434.0	2	screw
9.10.3	2.1011.405.2	2	nut m 8 p.1
9.10.4	0.066.1432.3	2	rocker arm
9.10.4.2	2.1559.021.0/40	1	bushing 15x19x22
9.10.5	2.1410.055.7	2	circlip 19
9.10.6.1	0.066.1431.0	1	pin
9.10.6.2	0.066.1430.0/10	1	support
9.10.7	2.1599.432.0	2	shoulder ring
16	2.1532.507.0	3	oil seal 17x3.53
17	0.012.2673.0	12	screw m 14 p.2x141
18.1	0.017.0868.3	1	engine head
18.1.2	0.078.1426.0	1	valve seat
18.1.3	0.066.1427.0	1	valve seat
18.1.4	0.007.1779.0/20	2	valve guide
18.1.5	0.012.9984.0/20	1	bush
18.1.6	2.3170.012.2	2	expansion plug Ø 30
18.2	0.010.6022.0	1	exhaust valve mm 39.1 / Ø mm 9
18.3	0.010.6017.0	1	inlet valve mm 43.63 / Ø mm 9
18.4	0.066.1425.0	2	cup
18.5	0.074.1423.0	4	conical valve cotter
18.6	2.4019.287.0	2	spring
18.7	2.1519.117.0	2	special oil seal
18.8	2.0432.161.7	1	stud bolt m 10 p.1.5 / p.1.25 x 40
18.9	2.0432.163.7	2	stud bolt m 10 p.1.5 / p.1.25 x 45
20	2.0432.011.7	3	stud bolt m 8 p.1.25 / p.1 x 40
21	2.0432.005.7	3	stud bolt m 8 p.1.5 / p.1 x 25
24	0.015.9190.0	1	head gasket mm 1.2
25	0.015.9191.0	1	head gasket mm 1.4
26	0.015.9192.0	1	head gasket mm 1.6

ENGINE OIL PUMP

Fig.	P/n	QTY	Name
------	-----	-----	------

Notes:
[XF 55 SPIRIT DT]

36	2.0169.005.2	2	screw m 6 p.1 x 12
37	2.1651.711.0	2	pin 8 x 14
38	0.013.1629.4/20	1	support
38.1	0.013.1629.3/20	1	support
38.1.1	2.1559.186.0	1	special bushing 26 x 31.5 x 35
38.2	2.1219.025.2/10	1	ring nut m 36 p.1.5
38.3	2.1410.057.1	1	circlip 15
38.4	2.1589.153.0	1	shoulder ring 15.2 x 19 x 1.00
38.5	2.1589.146.0	2	shoulder ring 15.2 x 19 x 0.15
38.6	2.1589.147.0	2	shoulder ring 15.2 x 19 x 0.10
38.7	2.2020.001.0	1	ball bearing 15 x 32 x 8.00
38.8	2.1589.148.0	1	shoulder ring 28.2 x 31.8 x 0.5
38.9	2.1589.150.0	2	shoulder ring 28.2 x 31.8 x 0.1
38.10	2.1589.151.0	2	shoulder ring 28.2 x 31.8 x 0.15
38.11.1	0.065.1558.6/10	1	bevel drive
38.11.2	0.065.1559.0	1	bush
38.12	2.2680.020.0	1	ring 12 x 15 x 12
38.13	2.2725.016.0	1	roller cage 15 x 21 x 12
38.14	2.0342.007.6	1	screw m 4 p.0.7 x 30
38.15	2.0399.128.2/10	1	screw m 8 p.1 x 8
38.16	2.2030.002.0	1	ball bearing 12 x 28 x 8
39	0.065.1560.0/30	2	gasket
40	0.065.1569.0/40	1	shaft
41	0.065.1562.0/10	1	joint
42	0.014.7994.4	1	oil pump
43	2.1470.006.2	2	lock washer 10
44	2.0112.323.2	2	screw m 10 p.1.5x70

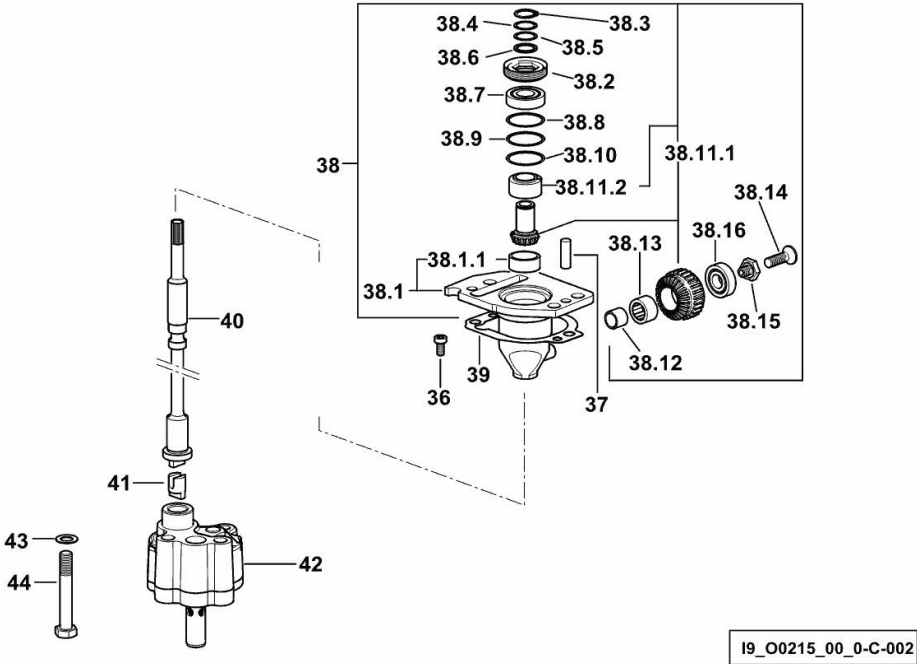

LUBRICATION

Fig.	P/n	QTY	Name
------	-----	-----	------

Notes:
[XF 55 SPIRIT DT]

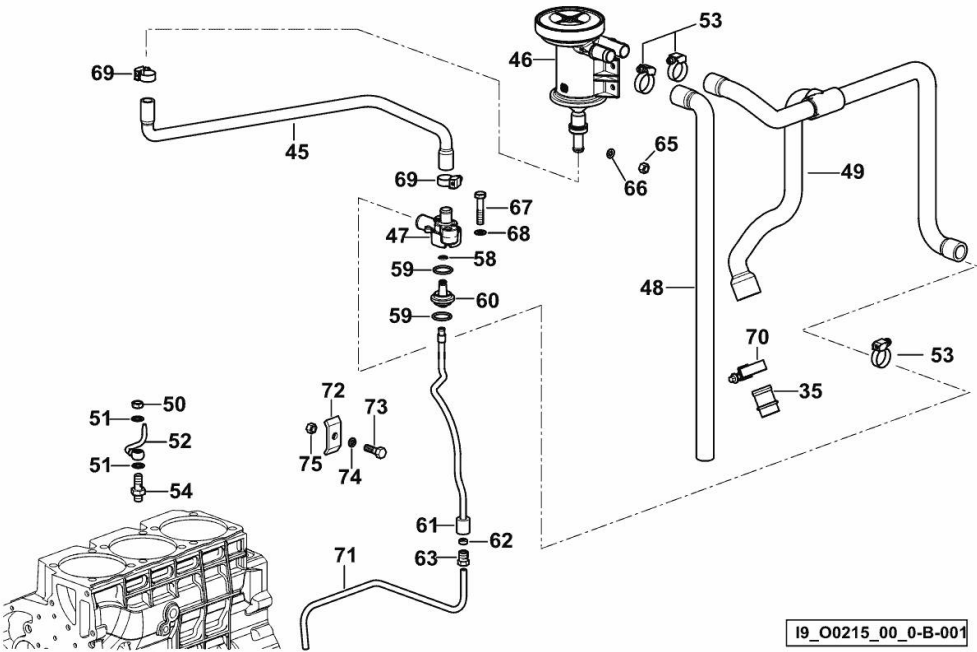

35	0.011.5918.0/10	1	tube
45	0.013.7012.0	1	tube
46	0.013.5023.0	1	sediment bowl
47	0.013.5291.0	1	flange
48	0.013.8200.0	1	tube
49	0.013.7640.0	1	tube
50	2.1099.108.2	3	special nut m 10 p.1
51	2.1560.006.0	12	gasket 10.2 x 16
52	0.086.1550.2	3	sprayer nozzle
53	2.6851.002.0	3	clamp Ø 20/32
54	0.065.1160.3/20	3	valve
58	2.1532.012.0	1	oil seal 6.75 x 1.78
59	2.1539.072.0	2	special oil seal 23.52 x 1.78
60	0.066.1558.0	1	bush
61	0.066.1557.2	1	tube
62	2.3350.003.1	1	nosepiece 8
63	2.3339.418.1	1	pipe fitting m 12 p.1
65	2.1120.103.2	2	nut m 6
66	2.1310.003.2	2	flat washer 7.4x14
67	2.0112.215.2	2	screw m 8 p.1.25 x 40
68	2.1474.009.2	2	spring washer 8
69	2.6851.001.0	2	clamp Ø 16/25
70	2.6851.003.0	1	clamp Ø 25/40
71	0.007.1427.0	1	tube
72	0.002.8816.0	1	small plate
73	2.0112.007.2	1	screw m 6 p.1 x 20
74	2.1470.002.2	1	lock washer 6
75	2.1011.103.2	1	nut m 6 p.1

LUBRICATION

Fig.	P/n	QTY	Name
------	-----	-----	------

Notes:
[XF 55 SPIRIT DT]

2	0.041.1135.4	1	plug 1" gas
2.2	2.1569.072.0	1	gasket 32 x 39.5 x 2
3	2.0312.205.2	2	screw
4	2.1480.014.1	2	washer 8
5	0.013.0942.0/10	1	pipe union
6	0.013.1387.0	1	small mesh
7	2.1532.515.0	1	rubber ring 1.78 x 53.70
11	2.1011.105.2	1	nut m 8 p.1.25
12	2.1470.004.2	1	lock washer 8
13	0.065.1538.0	1	flange
14	2.1539.040.0	1	special oil seal 21.82 x 3.53
15	2.1539.065.0	2	special oil seal 8.73 x 1.78
16	0.007.1624.2	1	dipstick

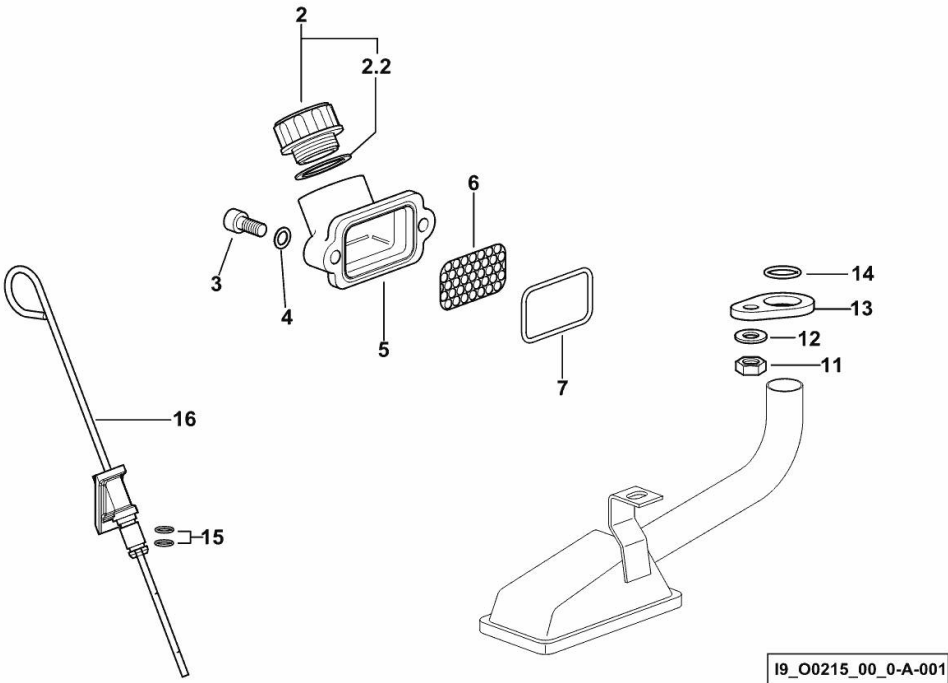

Thank you so much for reading.
Please click the “Buy Now!”
button below to download the
complete manual.



After you pay.

You can download the most
perfect and complete manual in
the world immediately.

Our support email:

ebooklibonline@outlook.com