

Section: ENGINE
CRANKCASE

9_M6511_00_0_A

Fig.	P/n	QTY	Name
------	-----	-----	------

Notes:
 [XF-55]

3	2.3199.312.2/10	1	plug
5	2.0439.273.7	6	stud bolt m 8
6	2.1559.188.2	3	bush 11.4 x 14 x16
7	2.1539.193.0	6	special oil seal 107.62x2.62
8	2.1560.010.0	1	gasket 14.2 x 20
9	2.3199.292.0	1	plug 1/4" gas
10	0.013.0536.4/30	1	crankcase
10.1	2.3130.001.1	9	plug 1/8" gas
10.2	2.3130.002.1	2	plug 1/4" gas
10.3	2.3130.003.1	2	plug 3/8" gas
10.4	0.000.0000.1		cannot be supplied
10.4.1	0.065.1112.7	1	support
10.4.1.2	2.1699.165.0	1	bush 12.3x15x16
10.4.2	0.065.1114.0/10	2	support
10.4.3	0.065.1116.3	1	support
10.4.3.2	2.1699.165.0	1	bush 12.3x15x16
10.4.5	0.065.1140.0	3	special bushing 59X55X20
10.4.6	0.065.1141.0	1	special bushing 59X55X30
10.4.7	0.066.1151.0	1	pin
10.4.8	0.065.1117.0	8	screw m 12 x 100
10.5	2.3179.012.0	1	plug 60
11	0.066.1152.0/10	4	gasket
14	2.1549.154.2	3	bush 4.8x5.8x16
24	2.3120.101.0	1	plug m 18 p.1.5
25	0.013.4946.0/10	1	sprayer nozzle
26	2.1560.014.0	1	washer 18.2 x 24

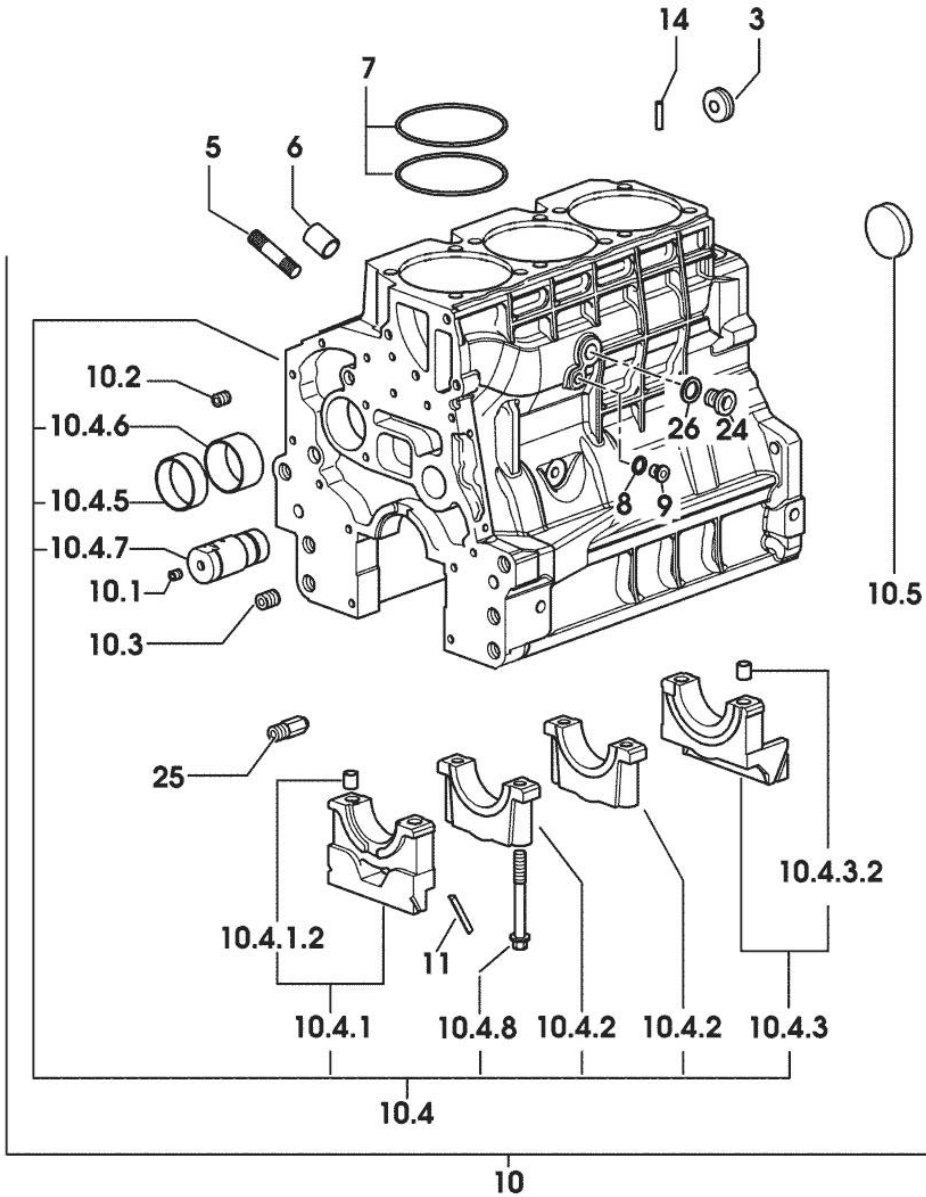

Section: ENGINE

TIMING CASE

Fig.	P/n	QTY	Name
------	-----	-----	------

Notes:

[XF-55]

15	2.0432.003.7	2	stud bolt m 8 p.1.25 / p.1 x 20
16	2.0312.214.2	7	screw m 8 p.1.25 x 40
17	2.1480.014.1	15	washer 8
18	0.013.4981.0	1	guard
19	0.065.1150.0/30	1	gasket
20	2.1470.004.2	4	lock washer 8
21	2.1011.405.2	2	nut m 8 p.1
22	2.0312.208.2	8	screw m 8 p.1.25 x 25
23	2.1529.167.0	1	oil seal

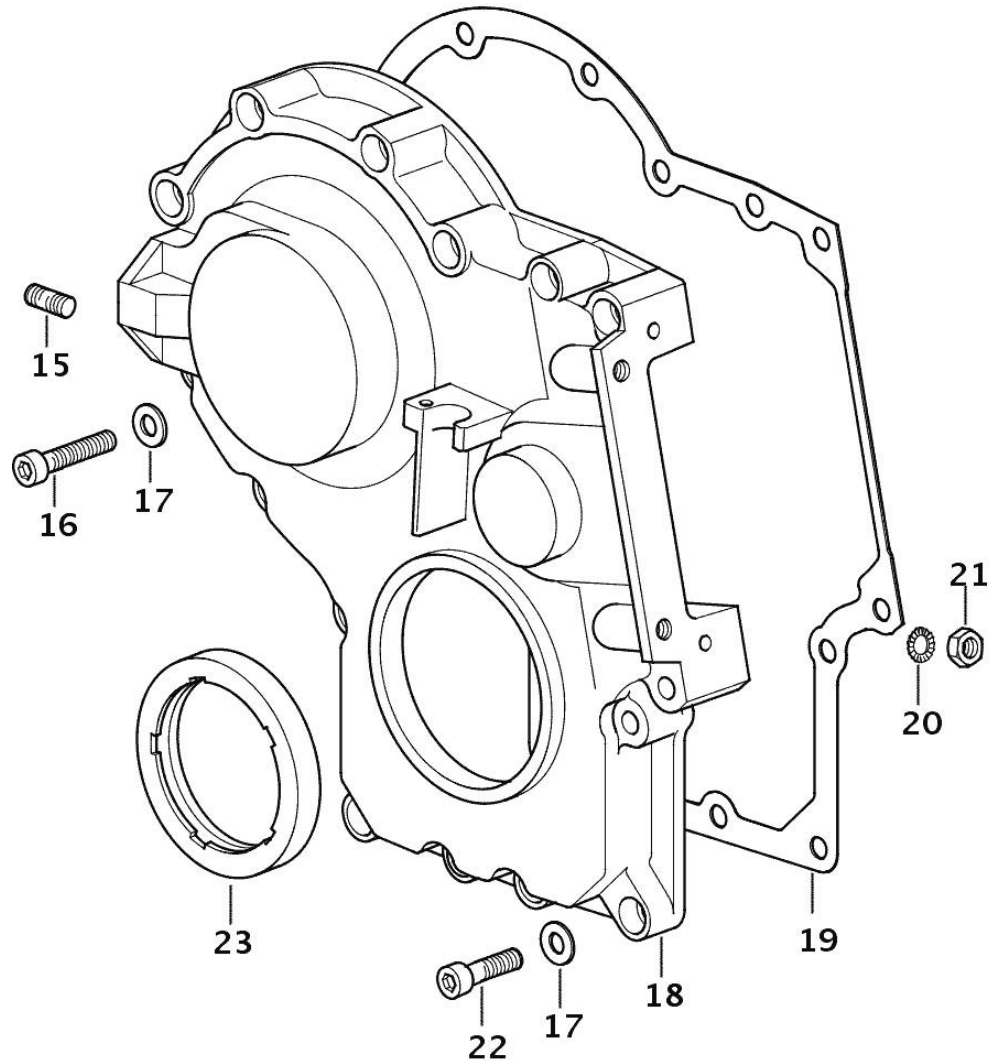
9_M6511_00_0_B

Section: ENGINE
CASING COVER

Fig.	P/n	QTY	Name
------	-----	-----	------

Notes:
 [XF-55]

1	0.065.1151.0	1	cover
2	0.065.1152.0	1	gasket
3	0.013.6368.0/10	4	stud bolt m 8 p.1 / = mm 46.5
4	2.1310.004.2	8	flat washer 8.4x17
5	2.1011.405.2	4	nut m 8 p.1

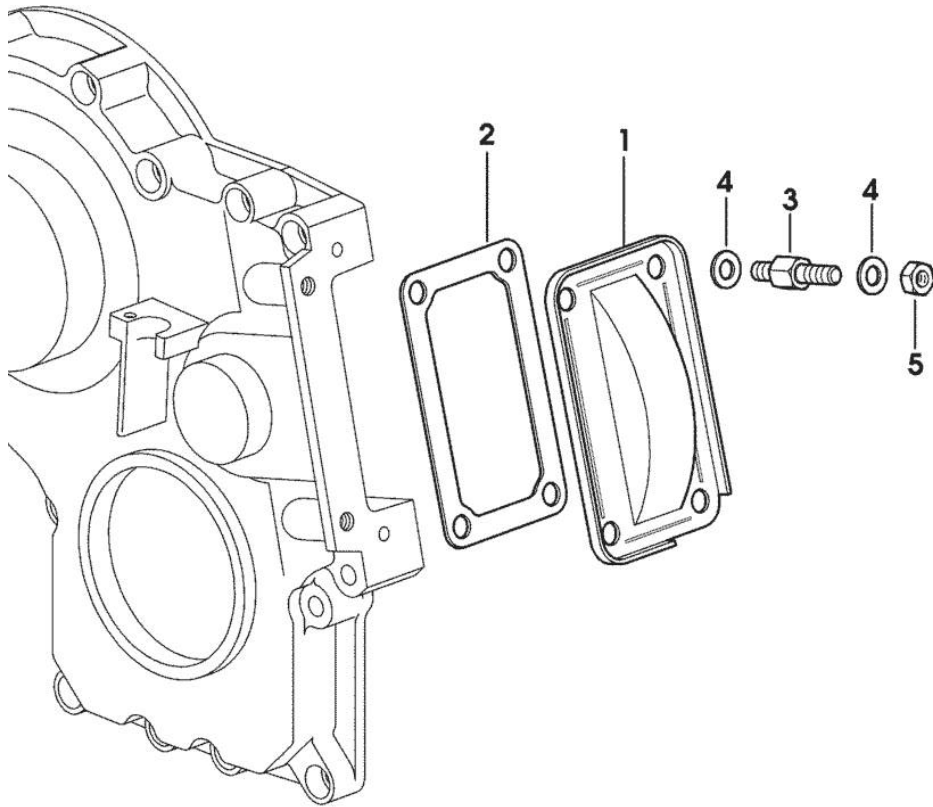

9_N1311_01_0_0

GUARD PLATE

Fig.	P/n	QTY	Name
------	-----	-----	------

Notes:
[XF-55]

1	0.007.1262.3/50	1	guard
2	0.007.1271.0/10	1	small column m 8 p.1.25 / L = mm 60
3	0.007.1272.0/10	2	small column m 8 p.1.25 / L = mm 50
5	2.1310.004.2	3	flat washer 8.4x17
7	2.0112.203.2	3	screw m 8 p.1.25 x 12

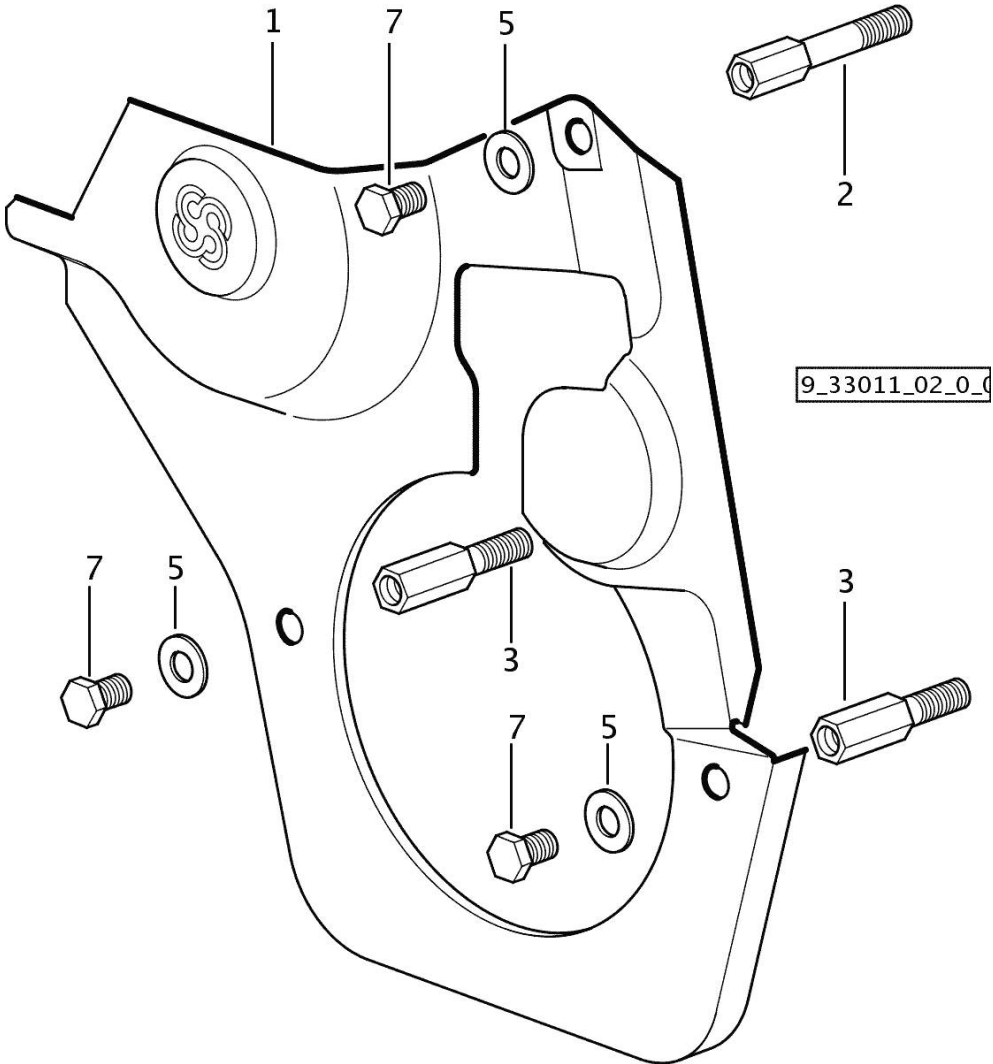

MONOBLOC ENGINE-GEARBOX CONNECTING FLANGE

Fig.	P/n	QTY	Name
------	-----	-----	------

Notes:
[XF-55]

1	0.007.7752.0/30	1	flange
2	2.0112.511.2	8	screw m 14 p.2 x 30
3	2.1651.912.0	2	cylindrical plug 12x28
4	2.1651.917.0	1	cylindrical plug 12x40
5	2.0432.257.7	1	stud bolt m 12 p.1.75 - 1.25 x 30
6	2.0439.250.7	1	stud bolt m 12 / m 10 x 30
7	0.011.9294.0/10	1	bush

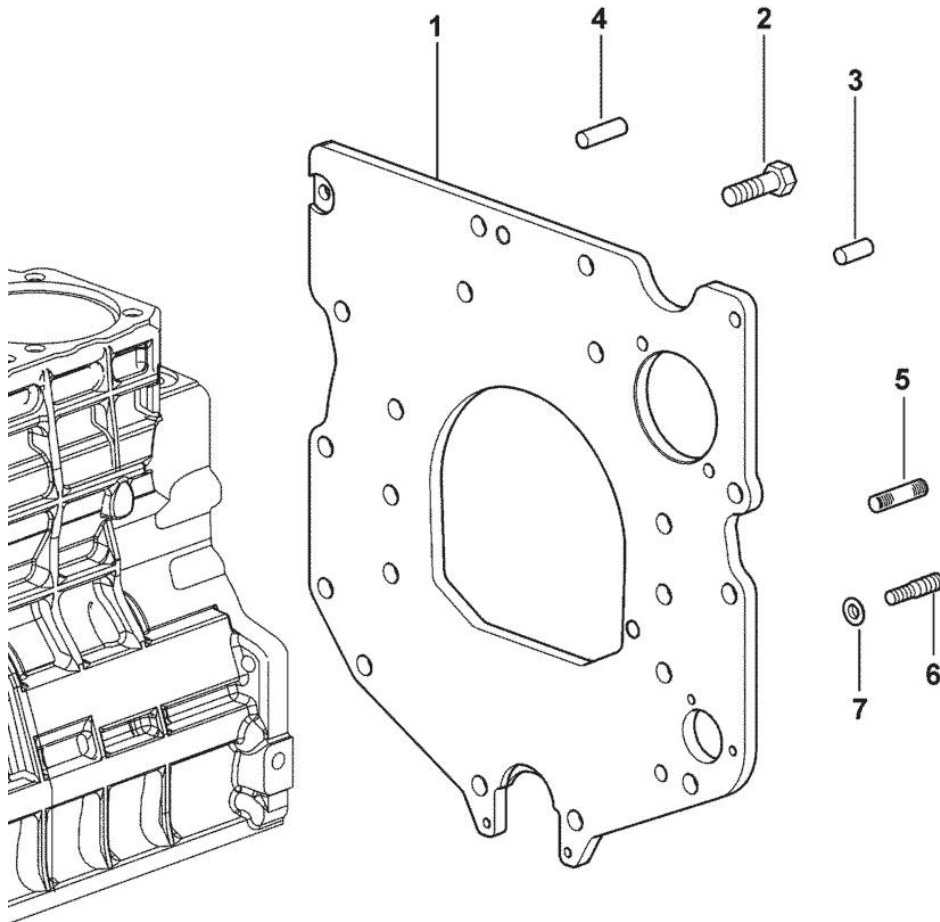

9_37311_01_0_0

Section: ENGINE

CRANKSHAFT

9_34812_00_0_0

Fig.	P/n	QTY	Name
------	-----	-----	------

Notes:
[XF-55]

4	2.3130.001.1	3	plug 1/8" gas
6	2.1720.006.0	2	key 4x6.5
7	0.007.1554.0/20	1	crankshaft
8	0.065.1215.0	4	main half bushing STANDARD
9	0.065.1216.0	4	main half bushing
10	0.065.1218.0	4	shim STANDARD
15	0.065.1254.0/20	1	gasket
16	0.007.1711.0/10	1	cover
17	2.1475.002.2	9	conical washer 8
18	2.0112.207.2	9	screw m 8 p 1.25 x 20
19	2.1529.073.0	1	special oil seal 110x130x13
20	2.1651.915.0	1	pin 12x35
22	2.1599.524.7	1	washer 21x60x12

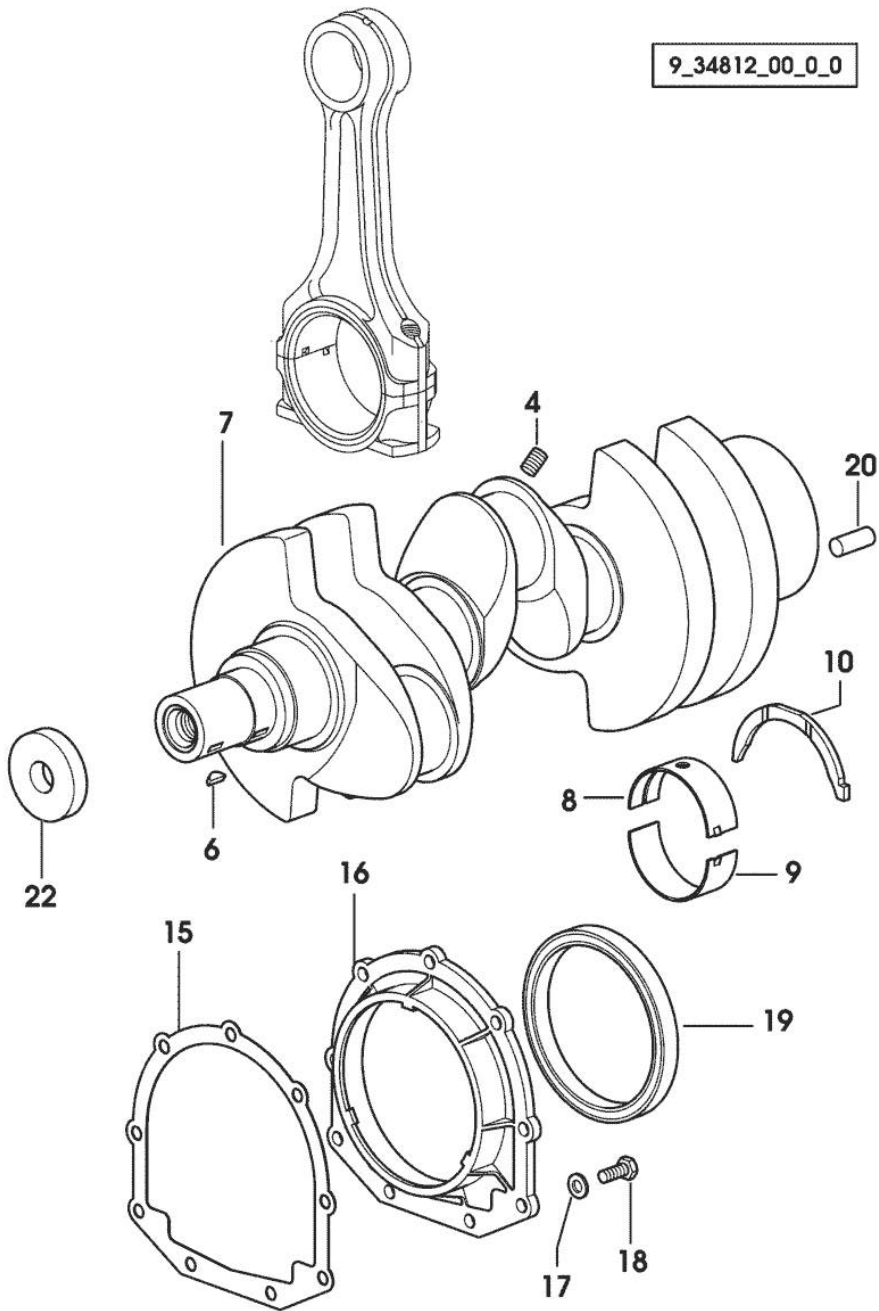

CYLINDER - PISTON - CONNECTING ROD

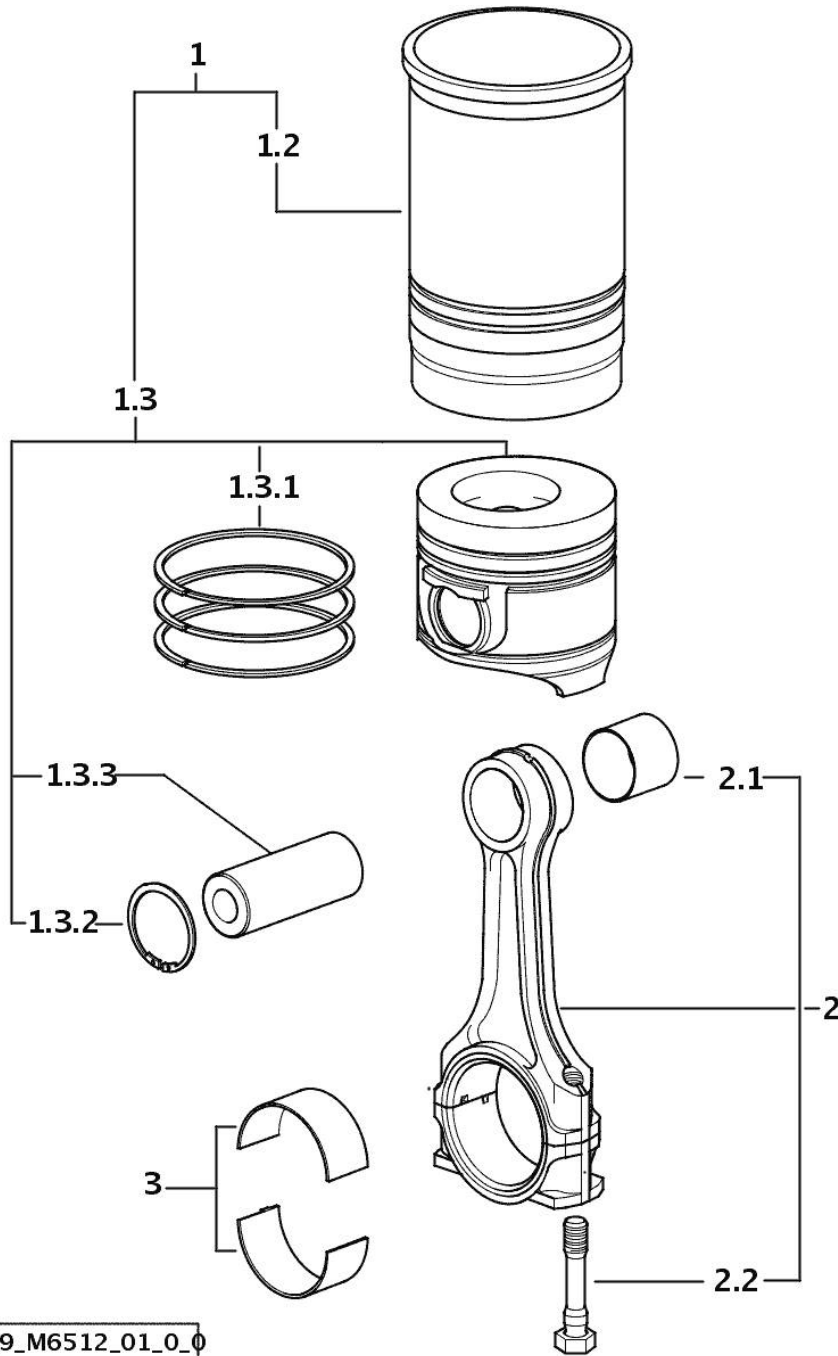

Fig.	P/n	QTY	Name
Notes:			
[XF-55]			
1	0.082.0065.A	3	cyl. piston assembly "A" - CLASS A
1	0.082.0065.B	3	cyl. piston assembly "B" - CLASS B
1.2	0.A12.2675.0	1	engine cylinder "A" - CLASS A
1.2	0.B12.2675.0	1	engine cylinder "B" - CLASS B
1.3	0.082.0060.A	1	complete piston "A" - CLASS A
1.3	0.082.0060.B	1	complete piston "B" - CLASS B
1.3.1	0.086.0052.6/10	1	piston ring set
1.3.2	2.1411.014.1	2	circlip 35
1.3.3	0.078.1236.0	1	piston pin Ø 18 / Ø 35 / L = mm 86
2	0.078.1220.3/30	3	engine connecting rod
2.1	2.1559.114.0/10	1	special bushing
2.2	2.0399.213.0	2	screw m 12 p.1.25x61.5
3	0.065.1225.0	6	con.rod half bushing STANDARD - A = 28.75 -> 29.00
3	0.065.1225.7	6	con.rod half bushing - mm 0.25
3	0.065.1225.8	6	con.rod half bushing - mm 0.50

9_M6512_01_0_0

Section: ENGINE

CRANKSHAFT PULLEY

Fig.	P/n	QTY	Name
------	-----	-----	------

Notes:
[XF-55]

1	0.013.6349.0/10	1	pulley
2	0.011.3515.0/10	1	hub Z = 48
3	0.065.1256.0	2	ring 45x52
4	2.1579.865.0	1	spacer 45.2x51.8x10
5	2.0439.195.7	1	stud bolt m 20 p.1.5x80
6	2.1019.094.7	1	nut m 20 p.1.5
7	2.0112.320.2	6	screw m 10 p.1.5 x 55
8	2.1470.006.2	6	lock washer 10

9_N1412_03_0_0

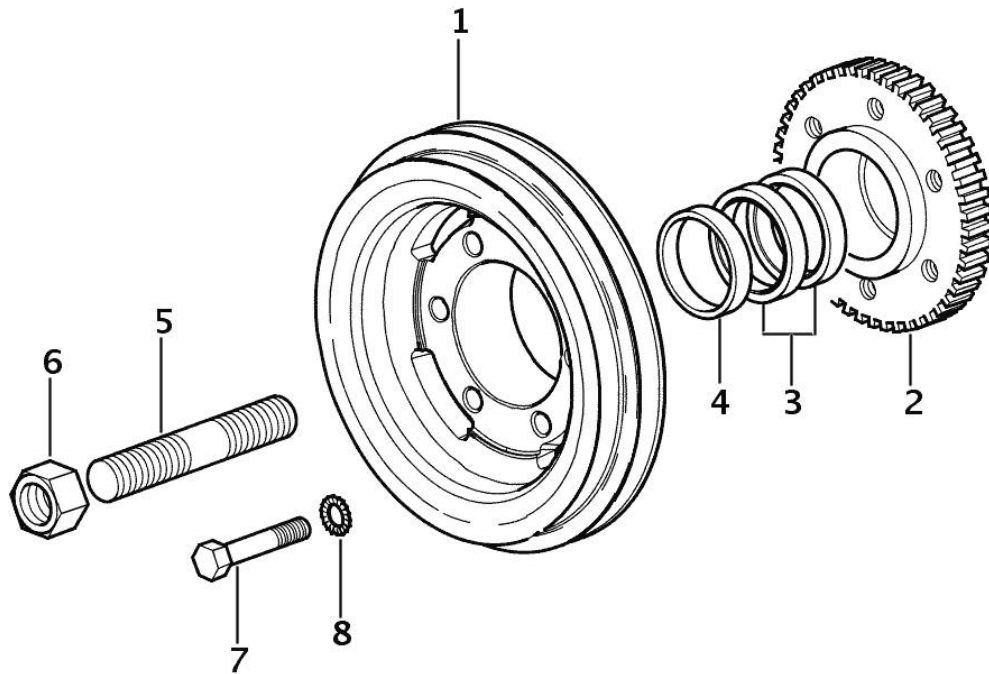
FLYWHEEL

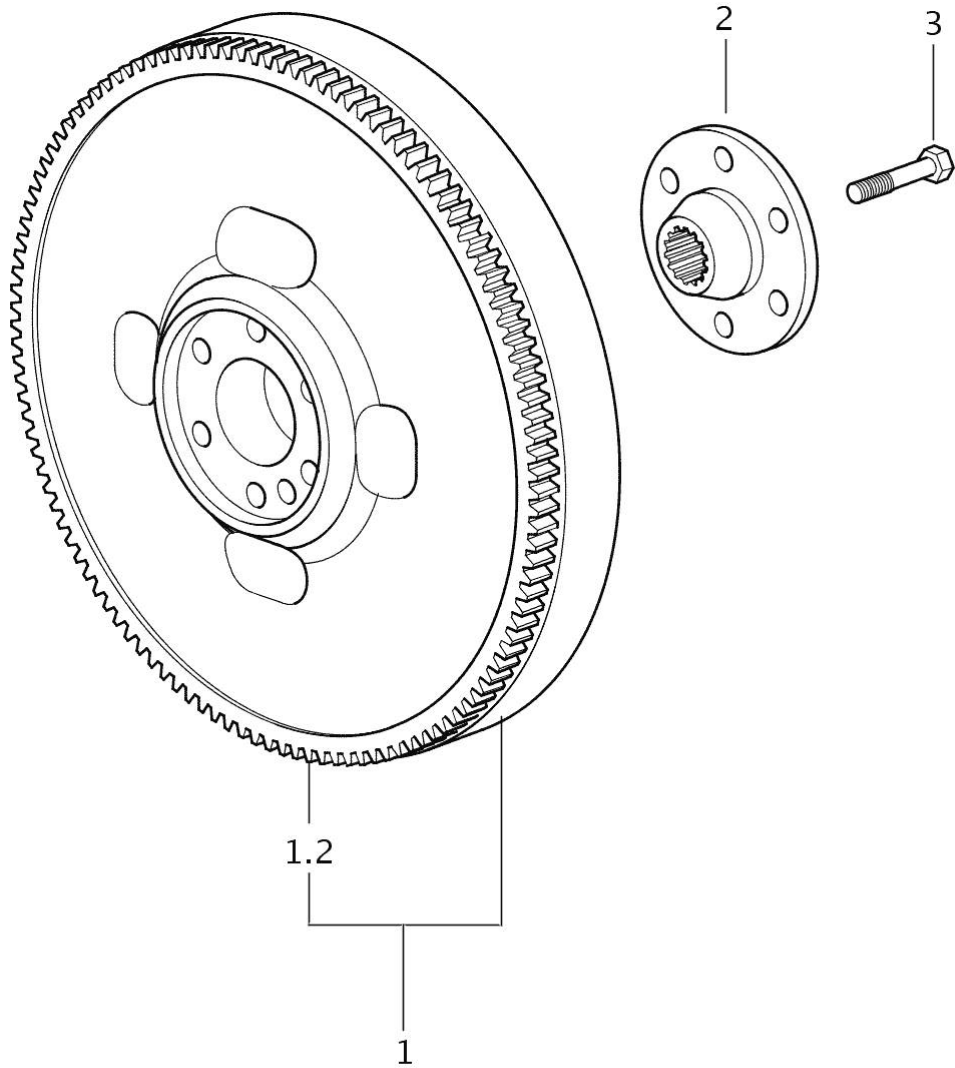

Fig.	P/n	QTY	Name
------	-----	-----	------

Notes:
[XF-55]

1	0.007.1883.3/10	1	flywheel
1.2	0.069.1242.0	1	crown wheel Z = 121
2	0.255.2525.0/10	1	flange
3	2.0139.022.2	6	screw m 12 p.1.25x55

9_37212_08_0_0

Section: ENGINE
ENGINE FLYWHEEL

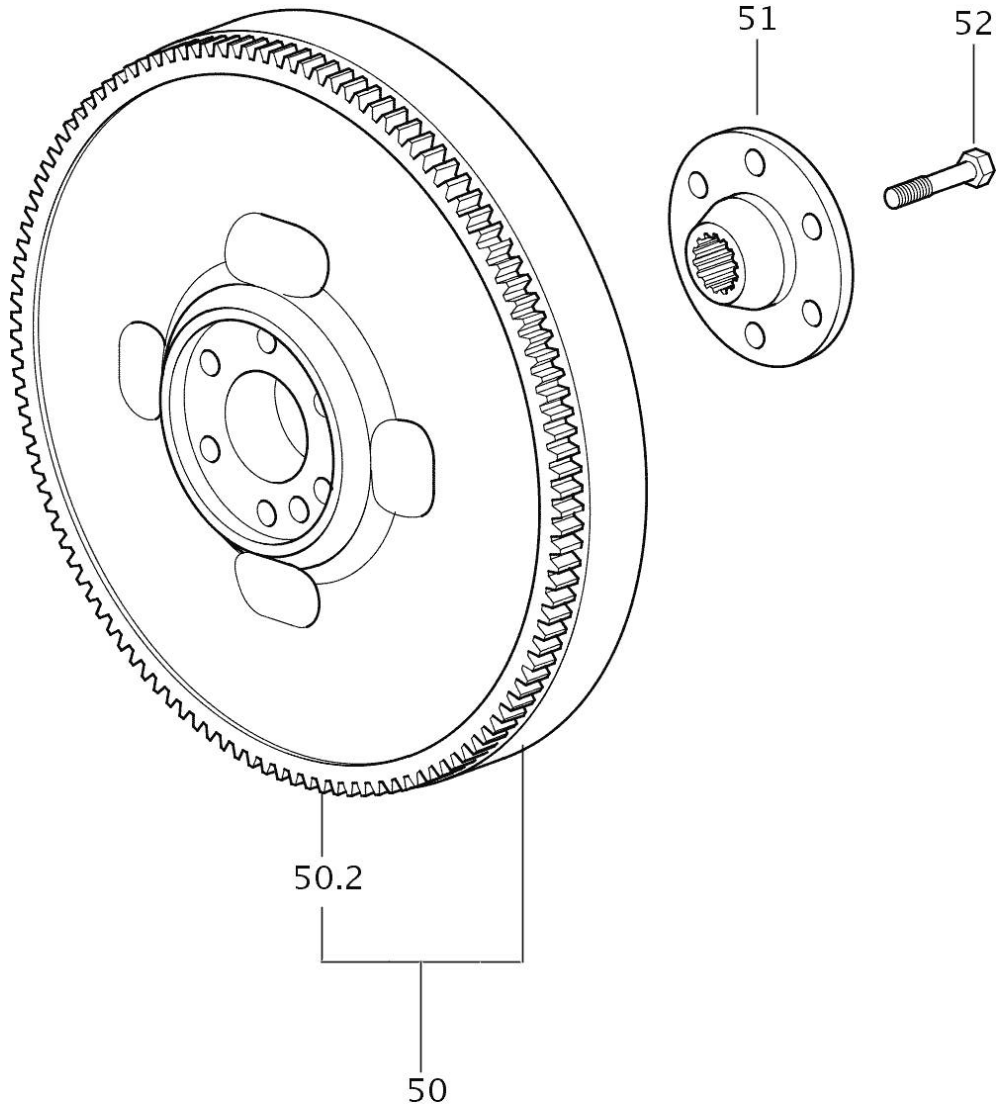

Fig.	P/n	QTY	Name
------	-----	-----	------

Notes:
[XF-55]

50	0.011.2162.3	1	flywheel
50.2	0.069.1242.0	1	crown wheel Z = 121
51	0.255.2525.0/10	1	flange
52	2.0139.022.2	6	screw m 12 p.1.25x55

9_37412_01_0_0

Section: ENGINE

CAMSHAFT

Fig.	P/n	QTY	Name
------	-----	-----	------

Notes:
[XF-55]

1	0.065.1331.2	6	rod
2	0.013.1473.3/20	1	camshaft
2.2	0.065.1324.0/10	1	gear Z = 32
3	0.065.1330.0	6	tappets
4	2.1559.398.0	1	bushing 10.5x13x12
5	0.013.5017.0	1	gear z=58
6	0.065.1350.0	1	small disc
7	2.0132.207.2	4	screw m 10 p.1 x 25
8	2.1410.016.1	1	circlip 40
9	0.065.1352.0	1	shim
10	0.065.1351.0	2	shoulder ring
11	0.065.1323.0/30	1	gear Z = 29
12	0.007.1177.3/20		gear z = 57 - WITH RED IDENTIFICATION STAMP
12.2	2.1559.185.0/10	1	bushing
13	0.007.1178.3/20		gear z = 57 - WITH YELLOW IDENTIFICATION STAMP
13.2	2.1559.185.0/10	1	bushing
14	0.007.1179.3/20		gear z = 57 - WITH GREEN IDENTIFICATION STAMP
14.2	2.1559.185.0/10	1	bushing
15	2.0312.205.2	2	screw
16	2.1480.014.1	2	washer 8
17	0.065.1353.0	1	small plate

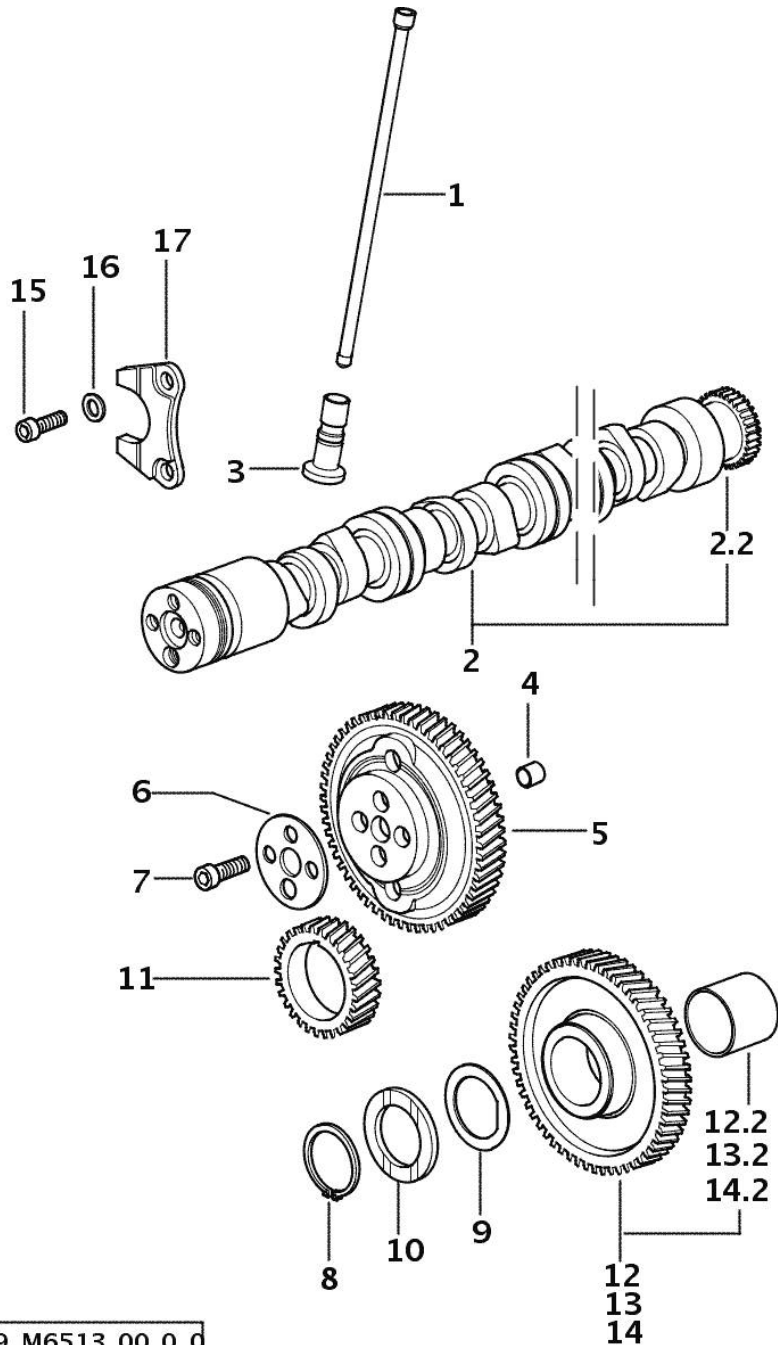

9_M6513_00_0_0

9_M6514_00_0_0

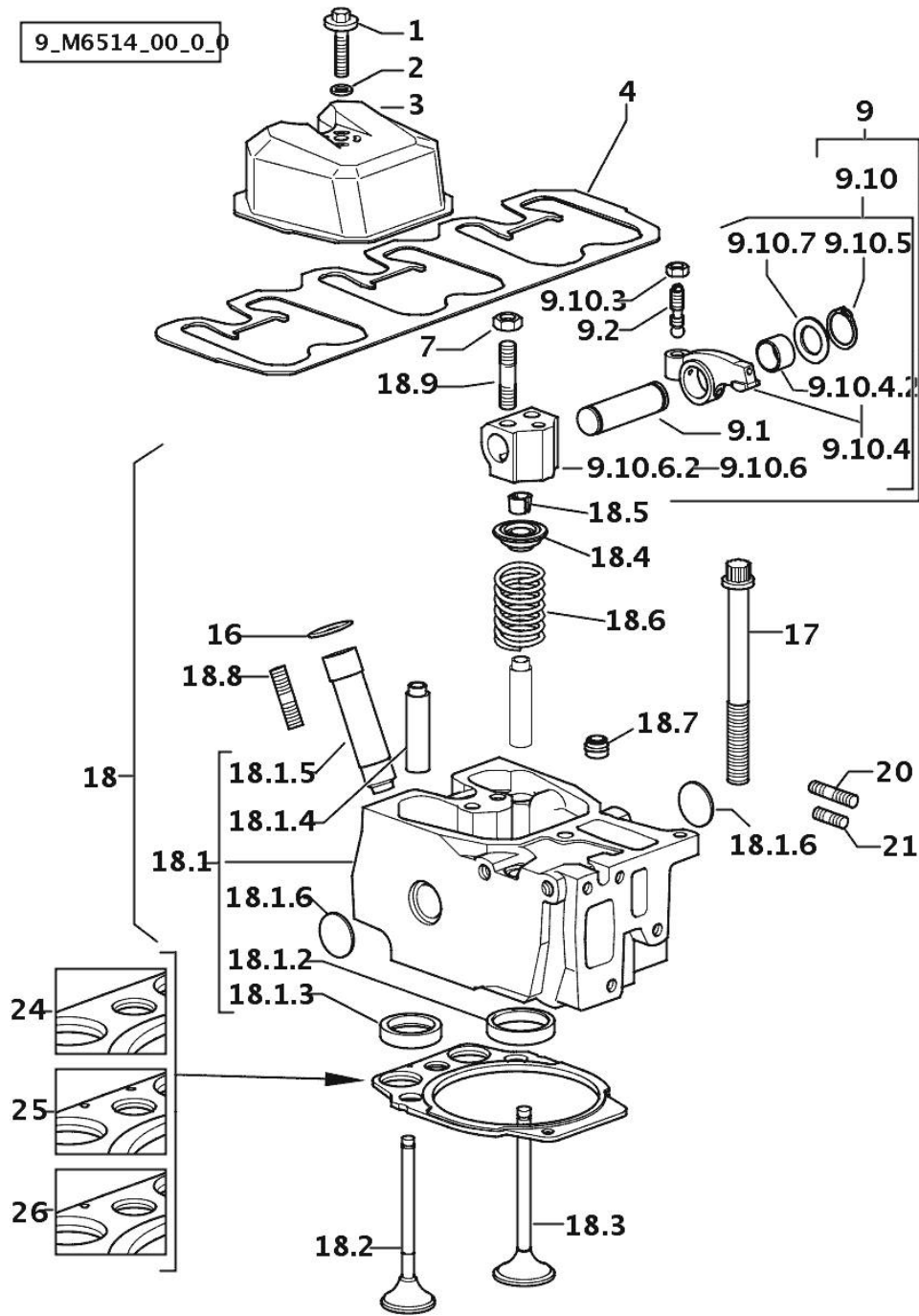

XF-55

Ref: 01.00.79

Section: ENGINE
CYLINDER HEAD

Fig.	P/n	QTY	Name
Notes:			
[XF-55]			
1	2.0399.288.2/10	3	screw m 8x36x46
2	2.1539.151.0	3	special oil seal 9.19 x 2.62
3	0.007.1139.0/10	3	small cap
4	0.069.1450.0/30	1	tappet gasket
7	2.1011.421.2	6	nut m 10 p.1.25
9	0.000.0000.1		cannot be supplied
9.1	0.066.1431.0	1	pin
9.2	0.021.1434.0	2	screw
9.10	0.000.0000.1		cannot be supplied
9.10.3	2.1011.405.2	2	nut m 8 p.1
9.10.4	0.066.1432.3	2	rocker arm
9.10.4.2	2.1559.021.0/40	1	bushing 15x19x22
9.10.5	2.1410.055.7	2	circlip 19
9.10.6	0.000.0000.1		cannot be supplied
9.10.6.2	0.066.1430.0/10	1	support
9.10.7	2.1599.432.0	2	shoulder ring
16	2.1532.507.0	3	oil seal 17x3.53
17	0.012.2673.0	12	screw m 14 p.2x141
18	0.000.0000.1		cannot be supplied
18.1	0.013.1478.3/50	1	head
18.1.2	0.078.1426.0	1	valve seat
18.1.3	0.066.1427.0	1	valve seat
18.1.4	0.007.1779.0/20	2	valve guide
18.1.5	0.012.9984.0/20	1	bush
18.1.6	2.3170.012.1	2	expansion plug 30
18.2	0.066.1421.0	1	exhaust valve
18.3	0.010.6016.0	1	inlet valve mm 43.63 / Ø mm 9
18.4	0.066.1425.0	2	cup
18.5	0.074.1423.0	2	conical valve cotter
18.6	2.4019.287.0	2	spring
18.7	2.1519.117.0	2	special oil seal
18.8	2.0432.161.7	1	stud bolt m 10 p.1.5 / p.1.25 x 40
18.9	2.0432.163.7	2	stud bolt m 10 p.1.5 / p.1.25 x 45
20	2.0432.011.7	3	stud bolt m 8 p.1.25 / p.1 x 40
21	2.0432.005.7	3	stud bolt m 8 p.1.5 / p.1 x 25
24	0.013.1887.0	4	gasket
25	0.013.1888.0	3	gasket
26	0.013.1889.0	1	gasket

INLET AND EXHAUST VALVES

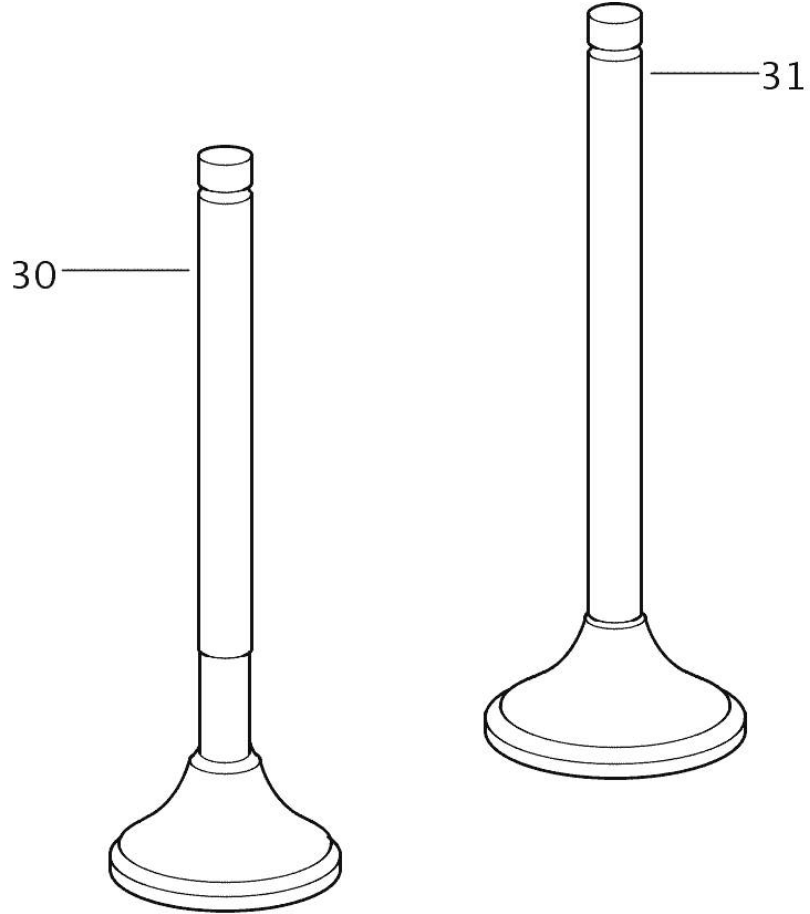

Fig.	P/n	QTY	Name
------	-----	-----	------

Notes:
[XF-55]

30	0.066.1421.0	3	exhaust valve
31	0.010.6016.0	3	inlet valve mm 43.63 / Ø mm 9

9_34814_02_0_0

INLET AND EXHAUST VALVE SPRINGS

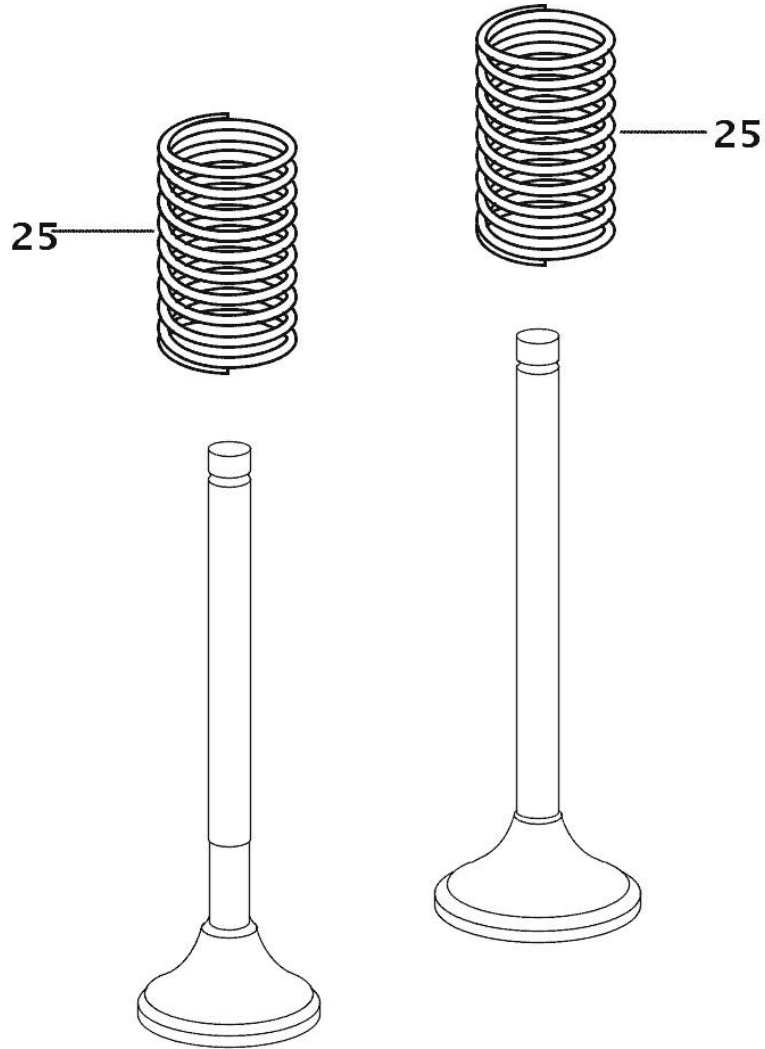

Fig.	P/n	QTY	Name
Notes:			
[XF-55]			
25	2.4019.287.0	6	spring

OIL PAN

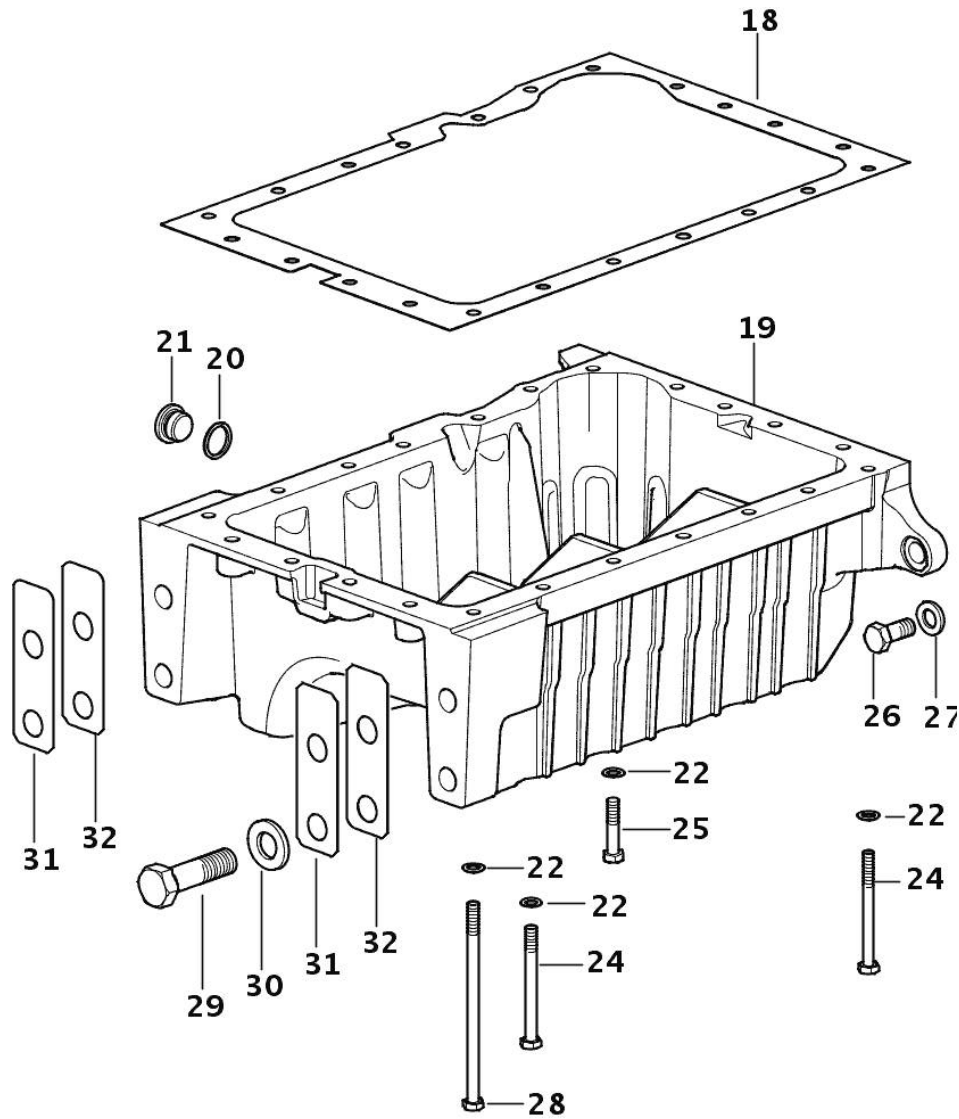

Fig.	P/n	QTY	Name
------	-----	-----	------

Notes:
[XF-55]

18	0.007.0614.0/10	1	gasket
19	0.007.1422.0/40	1	oil sump
20	2.1560.054.0	1	gasket 21 x 26
21	2.3199.001.2	1	plug 1/2" gas
22	2.1470.004.2	22	lock washer 8
24	2.0112.226.2	7	screw m 8 p.1.25 x 85
25	2.0112.215.2	13	screw m 8 p.1.25 x 40
26	2.0112.411.2	4	screw m 12 p.1.75 x 30
27	2.1470.007.2	4	lock washer 12
28	2.0112.239.2	2	screw m 8 p.1.25 x 150
29	2.0112.722.2	4	screw m 18 p.2.5 x 65
30	2.1475.007.7	4	washer 18
31	0.008.8586.0/10	4	shim mm 0.20
32	0.008.8587.0/10	8	shim mm 0.50

9_35115_01_0_0

Thank you so much for reading.
Please click the “Buy Now!”
button below to download the
complete manual.



After you pay.

You can download the most
perfect and complete manual in
the world immediately.

Our support email:

ebooklibonline@outlook.com