

ENGINE

Fig.	P/n	QTY	Name
-------------	------------	------------	-------------

Notes:

- EXPORT U.S.A. [XM 100]

1	25006912	1	engine ON ORDERING PLEASE ENGINE NO. REQUIRED
---	----------	---	---

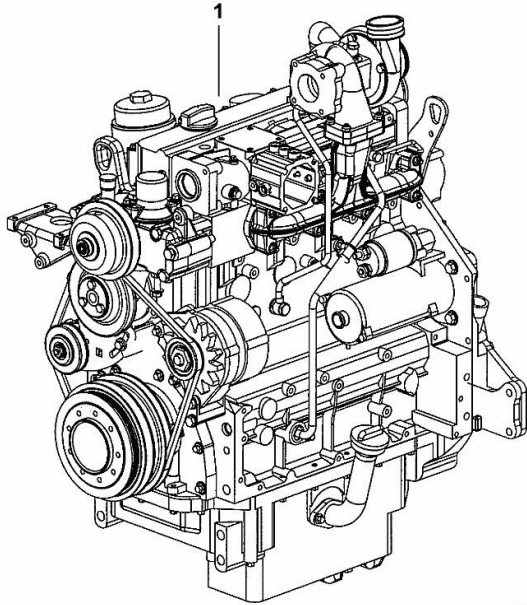

K9_N7119_02_0-A-001

FASTENINGS

Fig.	P/n	QTY	Name
------	-----	-----	------

Notes:
[XM 100]

Engine serial number:

10137429 10162148 10163662 10166331 10206122 10218817 10231907 10243769 10243812 10274567 10286754

1	01183645	12	screw EN 1662 -F-M8X35-10.9-ZNAL-A
2	04504325	1	gasket
3	01181406	1	bushing H 2341 -B11X8-FE/ZN12C*

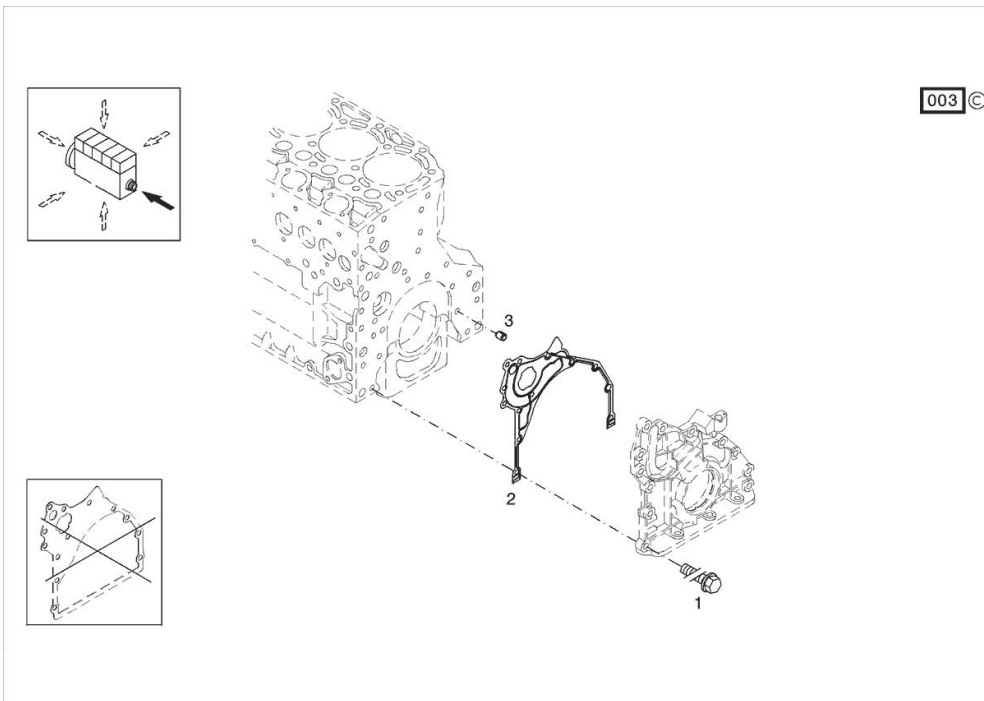
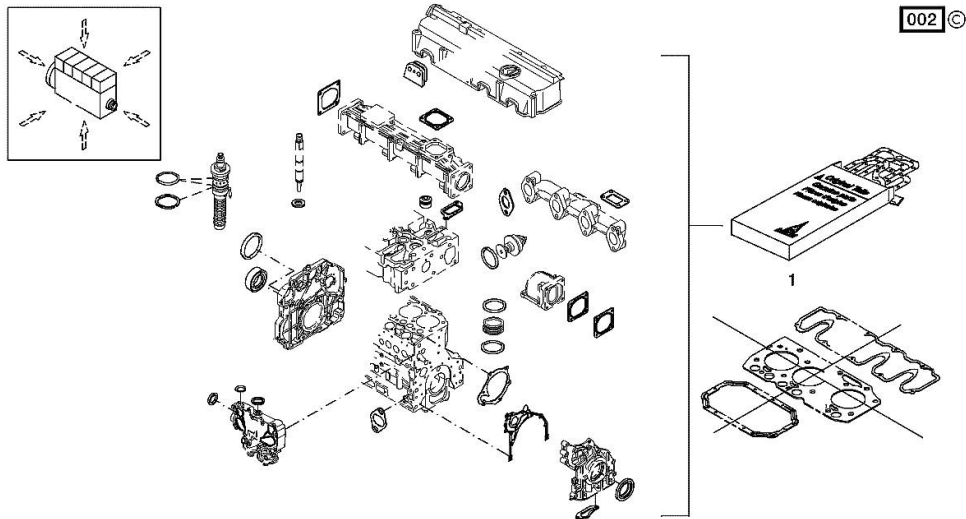

Fig.	P/n	QTY	Name
------	-----	-----	------

Notes:
 [XM 100]

Engine serial number:
 10137429 10162148 10163662 10166331 10206122 10218817 10231907 10243769 10243812 10274567 10286754

1	02937585	1	gasket set THE KIT DOES NOT CONTAIN ALL THE GASKETS: SEE SM 0199-99-9449
---	----------	---	--



Section: B0 - ENGINE
CRANKCASE BREATHER

Fig.	P/n	QTY	Name
------	-----	-----	------

Notes:
 [XM 100]

Engine serial number:

10137429 10162148 10163662 10166331 10206122 10218817 10231907 10243769 10243812 10274567 10286754

1	04203321	1	valve WITH POS.... (2)
2	04206233	1	gasket
3	01148431	2	screw - FROM THE MONTH OF ASSEMBLY SEE POS. (B) - UP TO THE MONTH OF ASSEMBLY (A) FROM THE MONTH OF ASSEMBLY A = 09.1995 B = POS. 950 ISO 4762 -M6X20-8.8-ZNAL-A
4	04207290	1	pipng
5	01124654	2	washer 6,4 d433 ISO 7092 -6-140HV-A4C*
950	01181965	2	screw - UP TO MONTH OF ASSEMBLY (A) - FROM MONTH OF ASSEMBLY SEE POS. (B) A = 08.1995 B = POS. 3 EN 1662 -F-M6X20-10.9-ZNAL-A

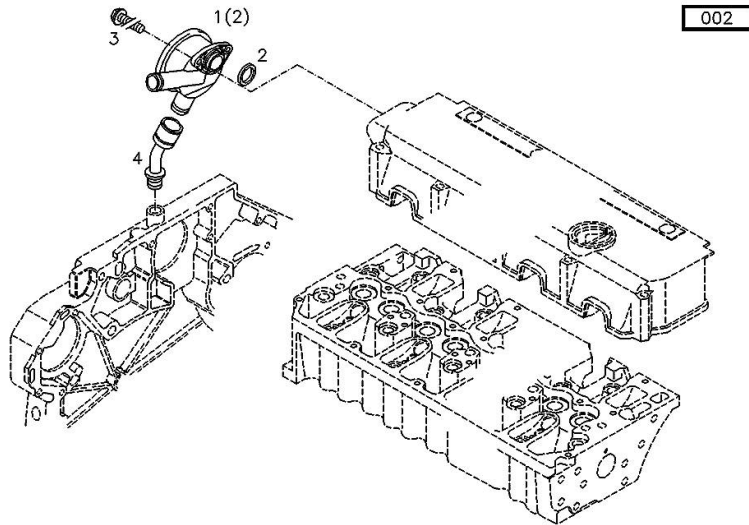
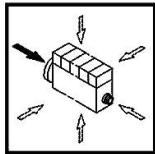

BLEEDING TUBE

Fig.	P/n	QTY	Name
------	-----	-----	------

Notes:
[XM 100]

1	04198572	1	tube
2	01178750	3	clamp DIN 3021 -A-29X15

001

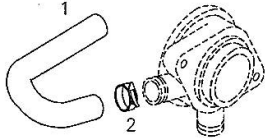

Section: B0 - ENGINE
KURBELGEHAEUSE

Fig.	P/n	QTY	Name
------	-----	-----	------

Notes:
 [XM 100]

Engine serial number:

10137429 10162148 10163662 10166331 10206122 10218817 10231907 10243769 10243812 10274567 10286754

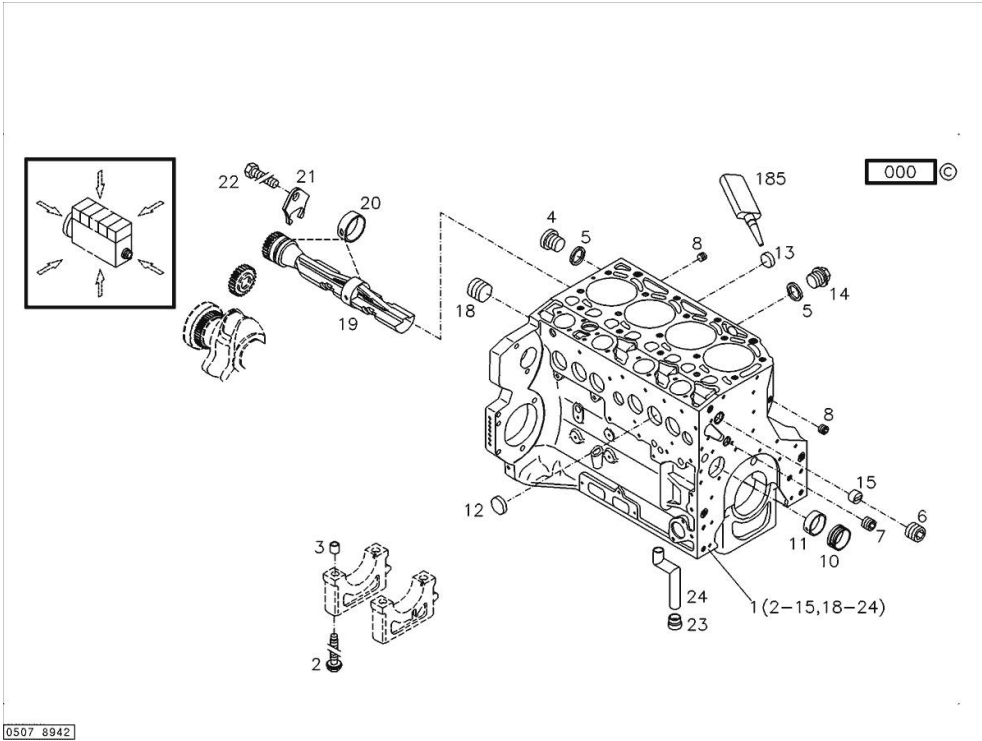

185	01319911	1	sealing compound ml. 50
1	04289939	1	crankcase MIT POS.... (2-15,18-24)
2	04254240	10	screw 50 Nm , 90° , 90°
3	04160764	10	bushing
4	01110423	1	screw 35 Nm DIN 908 -M14X1,5-ST-ZNPHRF
5	01118693	3	gasket 14x20 DIN 7603 -A14X20-CU
6	01180890	1	screw 95 Nm H 2812 -906-M30X1,5-ST-A4C-PRE80
7	01180906	1	screw H 2812 -906-M22X1,5-ST-A4C-PRE80
8	01182031	2	screw 35 Nm H 2812 -906-M14X1,5-ST-A3C-LOCTITE506
10	04251884	4	plug
11	04250086	1	ring
12	01148032	6	cover DIN 443 -A45-ZNPHR
13	01179634	4	plug H 2860 -A36-ST-FE/ZNPHR
14	01100940	2	screw 35 Nm DIN 7604 -AM14X1,5-ST-A4C
15	04202518	1	sleeve
18	04226536	1	bottom 30 Nm
19	04259301	2	shaft
20	04252834	4	bush
21	04251810	2	plug
22	01181672	2	nut H 2091 -4017-M8X16-10.9-GESCHW-MK-1.0

Section: B0 - ENGINE
KURBELGEHAEUSE

Fig.	P/n	QTY	Name
23	04255998	1	ring
24	04254026	1	pipng

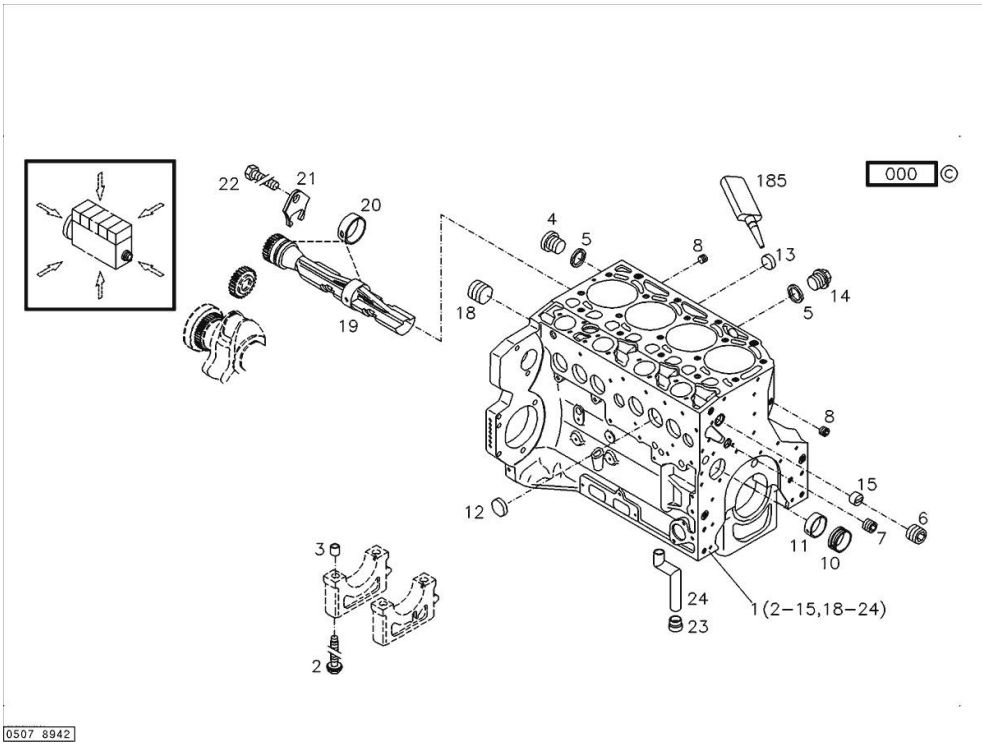

ACCESSORIES

Fig.	P/n	QTY	Name
------	-----	-----	------

Notes:
[XM 100]

Engine serial number:

10137429 10162148 10163662 10166331 10206122 10218817 10231907 10243769 10243812 10274567 10286754

3	04288659	1	support
4	01148261	2	screw ISO 4017 -M16X40-10.9-ZNAL-A
5	01181400	2	washer H 2308 -18X25X1,5-A4C

006 ©

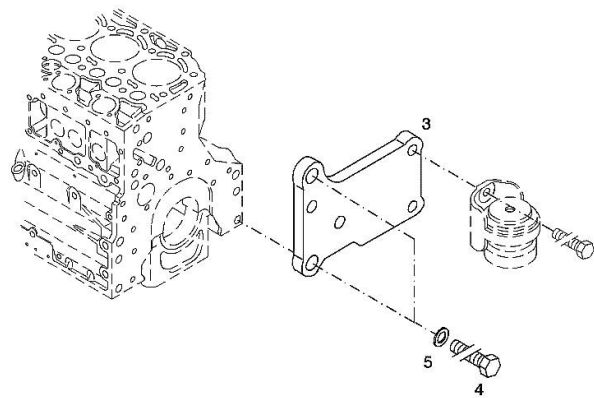
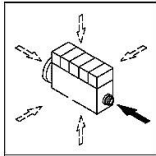

Section: B0 - ENGINE
OIL FILLER NECK

Fig.	P/n	QTY	Name
------	-----	-----	------

Notes:
 [XM 100]

Engine serial number:

10137429 10162148 10163662 10166331 10206122 10218817 10231907 10243769 10243812 10274567

1	04207099	1	tube
2	01178421	1	gasket
3	01181433	2	screw
			30 Nm

001 ©

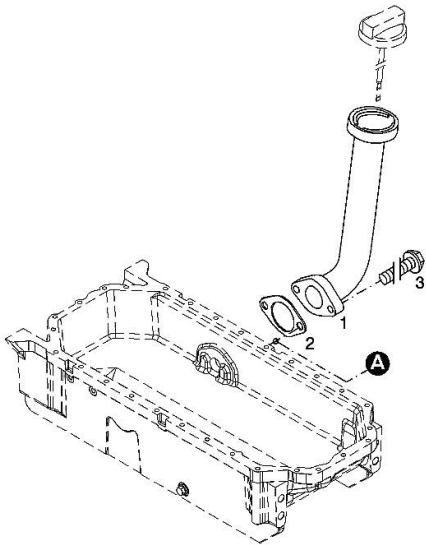
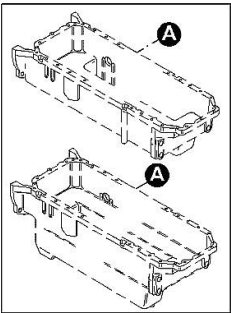
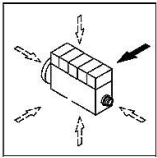

ACCESSORIES

Fig.	P/n	QTY	Name
------	-----	-----	------

Notes:
[XM 100]

Engine serial number:

10137429 10162148 10163662 10166331 10206122 10218817 10231907 10243769 10243812 10274567 10286754

3	01182016	2	disc H 2308 -13X24X3-ZNAL-A
4	01181400	2	washer H 2308 -18X25X1,5-A4C
5	04206926	1	plate dx/rh/re
6	04206927	1	plate sx/lh/li
7	01148137	2	screw - UP TO MONTH OF ASSEMBLY (A) - FROM MONTH OF ASSEMBLY SEE POS. (B) A = 06.2009 B = POS. 950 DIN 931 -M12X75-10.9-ZNAL-A
8	01148037	2	screw UP TO MONTH OF ASSEMBLY (A) - FROM MONTH OF ASSEMBLY SEE POS. (B) A = 06.2009 B = POS. 951 ISO 4014 -M16X75-10.9-OELGESCHW
950	01149017	2	screw - FROM MONTH OF ASSEMBLY SEE POS. (B) - UP TO MONTH OF ASSEMBLY (A) FROM MONTH OF ASSEMBLY A = 07.2009 B = 7
951	01180235	2	screw - FROM MONTH OF ASSEMBLY SEE POS. (B) - UP TO MONTH OF ASSEMBLY (A) FROM MONTH OF ASSEMBLY A = 07.2009 B= Pos.8 DIN 34800 -BM12X75-10.9-ZNAL-A H 2032 -HBM16X75-10.9-GESCHW

003 ©

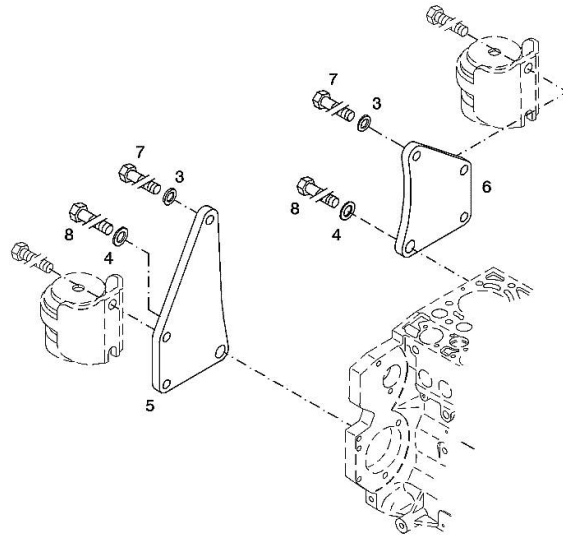
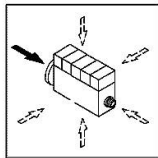

ACCESSORIES

Fig.	P/n	QTY	Name
-------------	------------	------------	-------------

Notes:
[XM 100]

Engine serial number:

10137429 10162148 10163662 10166331 10206122 10218817 10231907 10243769 10243812 10274567 10286754

3	04288660	1	support
4	01148261	2	screw ISO 4017 -M16X40-10.9-ZNAL-A
5	01181400	2	washer H 2308 -18X25X1,5-A4C

003 ©

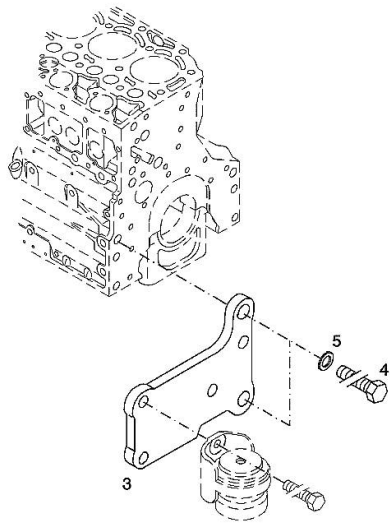
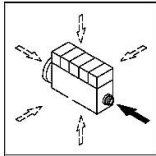

FILLER CAP

Fig.	P/n	QTY	Name
------	-----	-----	------

Notes:
[XM 100]

Engine serial number:
10137429 10162148 10163662 10166331 10206122 10218817 10231907 10243769 10243812 10274567

1	01180286	1	plug H 2875 -B2-OL40-166X4-130X12
---	----------	---	--------------------------------------

000

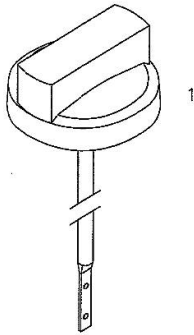

PISTON COOL.NOZZLE

Fig.	P/n	QTY	Name
------	-----	-----	------

Notes:
[XM 100]

Engine serial number:

10137429 10162148 10163662 10166331 10206122 10218817 10231907 10243769 10243812 10274567 10286754

1	04207521	1	sprayers
---	----------	---	----------

001 ©

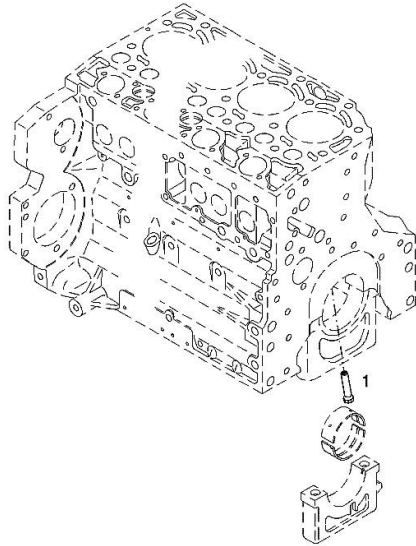
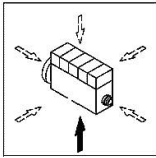

FLANGE

Fig.	P/n	QTY	Name
------	-----	-----	------

Notes:
[XM 100]

Engine serial number:

10137429 10162148 10163662 10166331 10206122 10218817 10231907 10243769 10243812 10274567 10286754

1	04283992	1	oil pump WITH POS.... (2,3)
2	04253372	1	oil seal
3	01133718	8	screw DIN 7991 -M6X16-8.8-A4C

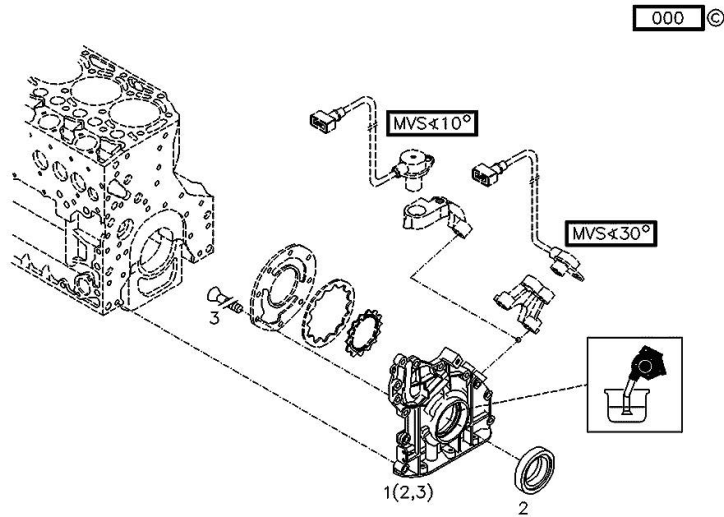
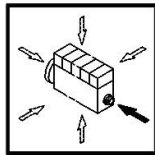

Section: B0 - ENGINE
KURBELGEHAEUSE

Fig.	P/n	QTY	Name
------	-----	-----	------

Notes:
 [XM 100]

185	01319911	1	sealing compound ml. 50
1	04297344	1	crankcase MIT POS.... (2-15,18-24)
2	04254240	10	screw 50 Nm , 90° , 90°
3	04160764	10	bushing
4	01110423	1	screw 35 Nm DIN 908 -M14X1,5-ST-ZNPHRF
5	01118693	3	gasket 14x20 DIN 7603 -A14X20-CU
6	01180890	1	screw 95 Nm H 2812 -906-M30X1,5-ST-A4C-PRE80
7	04292706	1	plug 80 Nm
8	01182031	2	screw 35 Nm H 2812 -906-M14X1,5-ST-A3C-LOCTITE506
9	01101342	1	oil seal DIN 7603 -D22X27-CU
10	04251884	4	plug
11	04250086	1	ring
12	01148032	6	cover DIN 443 -A45-ZNPHR
13	01148031	4	plug DIN 443 -A36-ZNPHR
14	01100940	2	screw 35 Nm DIN 7604 -AM14X1,5-ST-A4C
15	04202518	1	sleeve
18	04226536	1	bottom 30 Nm
19	04298243	2	shaft
20	04252834	4	bush
21	04251810	2	plug
22	01181672	2	nut H 2091 -4017-M8X16-10.9-GESCHW-MK-1.0
23	04255998	1	ring
24	04291215	1	tube

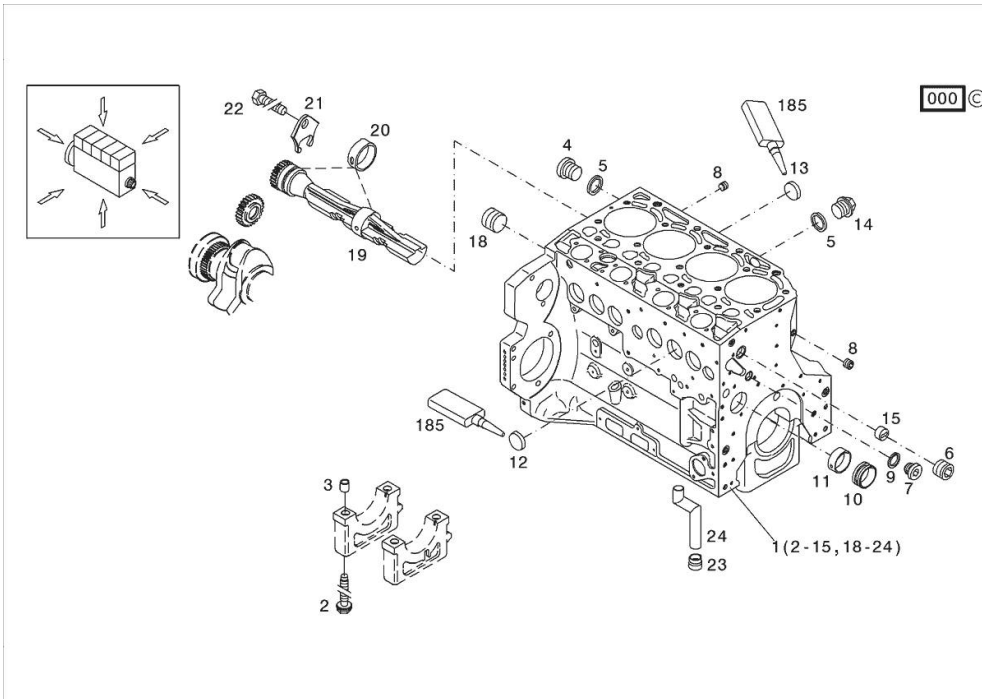

Thank you so much for reading.
Please click the “Buy Now!”
button below to download the
complete manual.



After you pay.

You can download the most
perfect and complete manual in
the world immediately.

Our support email:

ebooklibonline@outlook.com