

ENGINE

Fig.	P/n	QTY	Name
-------------	------------	------------	-------------

Notes:

- EXPORT U.S.A. [XM 110 HI-LEVEL]

1	25006914	1	engine ON ORDERING PLEASE ENGINE NO. REQUIRED
---	----------	---	---

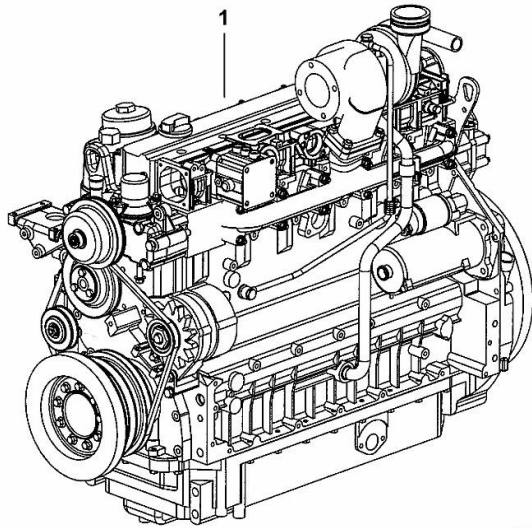

K9_N7219_02_0-A-001

FASTENINGS

Fig.	P/n	QTY	Name
------	-----	-----	------

Notes:
[XM 110 HI-LEVEL]

Engine serial number:
10116591 10191692 10223750 10268967 10285241 10285282 10286560 10299253 10300442 10570548

1	01183645	12	screw EN 1662 -F-M8X35-10.9-ZNAL-A
2	04504325	1	gasket
3	01181406	1	bushing H 2341 -B11X8-FE/ZN12C*

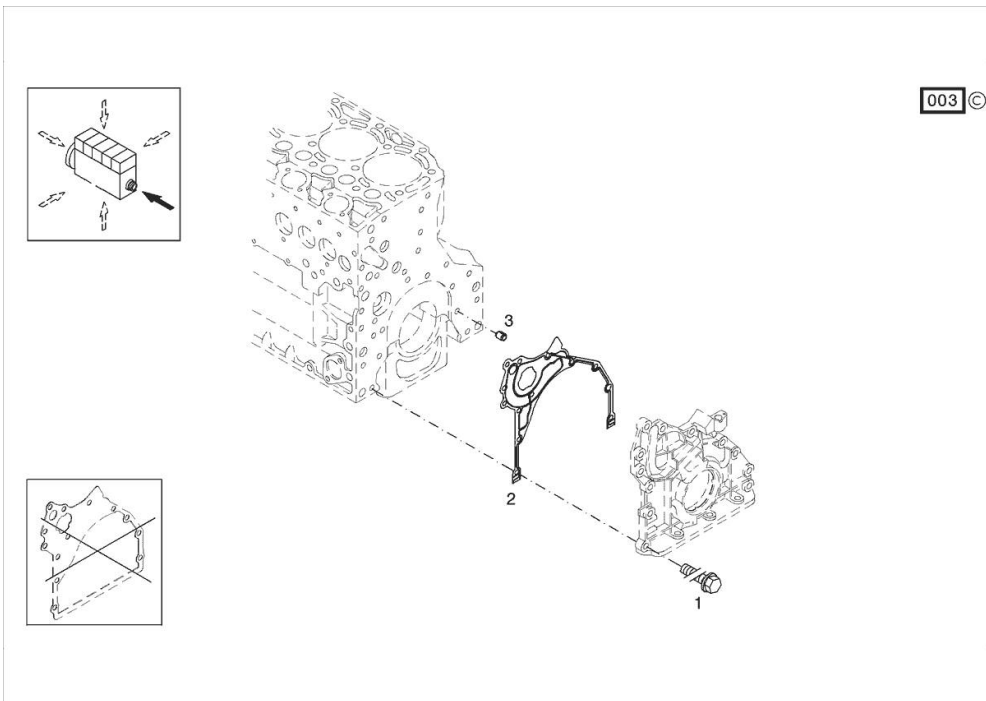

Section: B0 - ENGINE

BLEEDING TUBE

Fig.	P/n	QTY	Name
------	-----	-----	------

Notes:
[XM 110 HI-LEVEL]

1	04198572	1	tube
2	01178750	3	clamp DIN 3021 -A-29X15

001

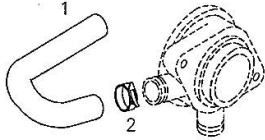

Section: B0 - ENGINE
CRANKCASE BREATHER

Fig.	P/n	QTY	Name
------	-----	-----	------

Notes:
 [XM 110 HI-LEVEL]

Engine serial number:
 10116591 10191692 10223750 10268967 10285241 10285282 10286560 10299253 10300442 10570548

1	04203321	1	valve WITH POS.... (2)
2	04206233	1	gasket
3	01148431	2	screw - FROM THE MONTH OF ASSEMBLY SEE POS. (B) - UP TO THE MONTH OF ASSEMBLY (A) FROM THE MONTH OF ASSEMBLY A = 09.1995 B = POS. 950 ISO 4762 -M6X20-8.8-ZNAL-A
4	04207290	1	pipng
5	01124654	2	washer 6,4 d433 ISO 7092 -6-140HV-A4C*
950	01181965	2	screw - UP TO MONTH OF ASSEMBLY (A) - FROM MONTH OF ASSEMBLY SEE POS. (B) A = 08.1995 B = POS. 3 EN 1662 -F-M6X20-10.9-ZNAL-A

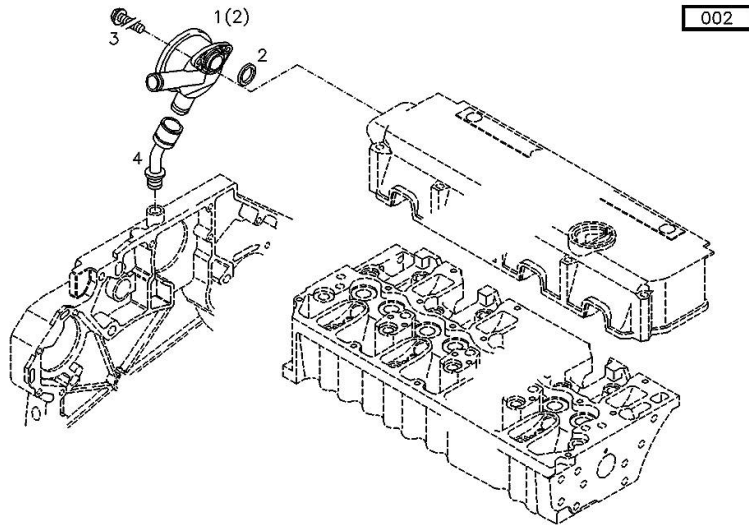
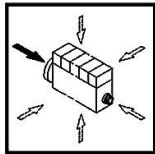

ACCESSORIES

Fig.	P/n	QTY	Name
------	-----	-----	------

Notes:
[XM 110 HI-LEVEL]

Engine serial number:
10116591 10191692 10223750 10268967 10285241 10285282 10286560 10299253 10300442 10570548

3	04288659	1	support
4	01148261	2	screw ISO 4017 -M16X40-10.9-ZNAL-A
5	01181400	2	washer H 2308 -18X25X1,5-A4C

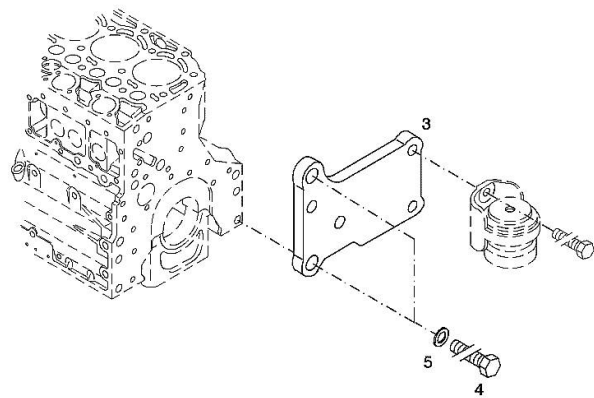
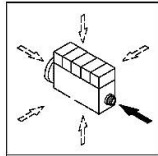

006 ©

Section: B0 - ENGINE
OIL FILLER NECK

Fig.	P/n	QTY	Name
------	-----	-----	------

Notes:
 [XM 110 HI-LEVEL]

Engine serial number:
 10116591 10191692 10223750 10268967 10285241 10285282 10286560 10299253 10300442 10570548

1	04207099	1	tube
2	01178421	1	gasket
3	01181433	2	screw
			30 Nm

001 ©

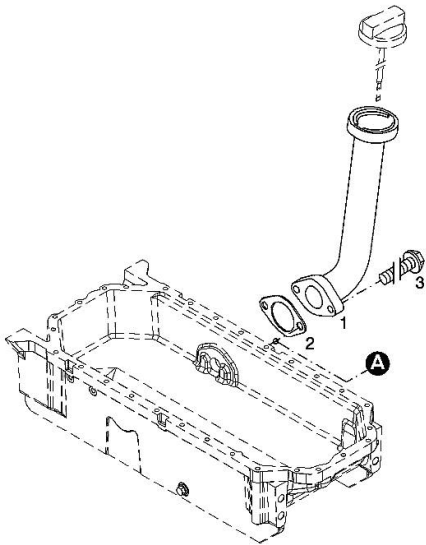
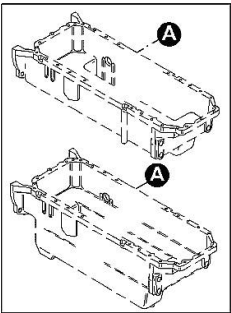
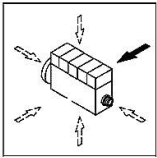

Section: B0 - ENGINE
SERIE GUARNIZIONI

Fig.	P/n	QTY	Name
------	-----	-----	------

Notes:
 [XM 110 HI-LEVEL]

Engine serial number:
 10116591 10191692 10223750 10268967 10285241 10285282 10286560 10299253 10300442 10570548

1	02937586	1	gasket set THE KIT DOES NOT CONTAIN ALL THE GASKETS: SEE SM 0199-99-9449
---	----------	---	--

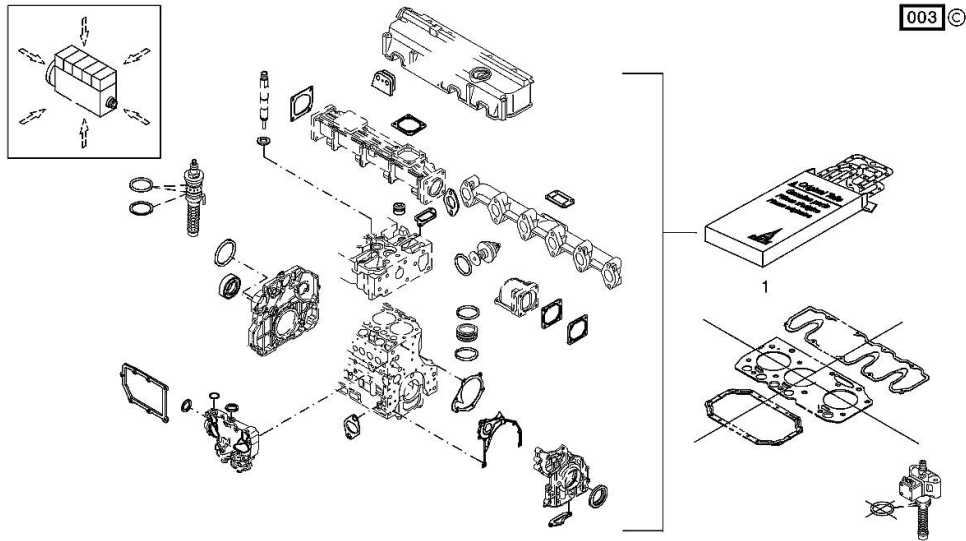

ACCESSORIES

Fig.	P/n	QTY	Name
------	-----	-----	------

Notes:
[XM 110 HI-LEVEL]

Engine serial number:

10116591 10191692 10223750 10268967 10285241 10285282 10286560 10299253 10300442 10570548

3	01182016	2	disc H 2308 -13X24X3-ZNAL-A
4	01181400	2	washer H 2308 -18X25X1,5-A4C
5	04206926	1	plate dx/rh/re
6	04206927	1	plate sx/lh/li
7	01148137	2	screw - UP TO MONTH OF ASSEMBLY (A) - FROM MONTH OF ASSEMBLY SEE POS. (B) A = 06.2009 B = POS. 950 DIN 931 -M12X75-10.9-ZNAL-A
8	01148037	2	screw UP TO MONTH OF ASSEMBLY (A) - FROM MONTH OF ASSEMBLY SEE POS. (B) A = 06.2009 B = POS. 951 ISO 4014 -M16X75-10.9-OELGESCHW
950	01149017	2	screw - FROM MONTH OF ASSEMBLY SEE POS. (B) - UP TO MONTH OF ASSEMBLY (A) FROM MONTH OF ASSEMBLY A = 07.2009 B = 7
951	01180235	2	screw - FROM MONTH OF ASSEMBLY SEE POS. (B) - UP TO MONTH OF ASSEMBLY (A) FROM MONTH OF ASSEMBLY A = 07.2009 B= Pos.8 DIN 34800 -BM12X75-10.9-ZNAL-A H 2032 -HBM16X75-10.9-GESCHW

003 ©

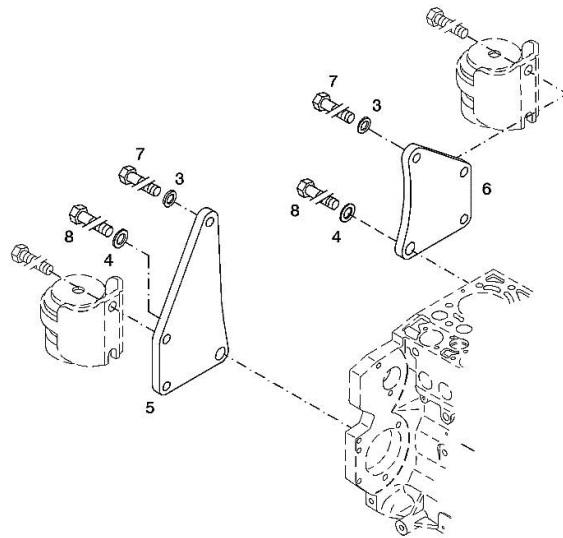
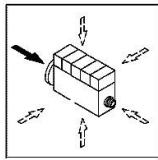

ACCESSORIES

Fig.	P/n	QTY	Name
------	-----	-----	------

Notes:
[XM 110 HI-LEVEL]

Engine serial number:
10116591 10191692 10223750 10268967 10285241 10285282 10286560 10299253 10300442 10570548

3	04288660	1	support
4	01148261	2	screw ISO 4017 -M16X40-10.9-ZNAL-A
5	01181400	2	washer H 2308 -18X25X1,5-A4C

003 ©

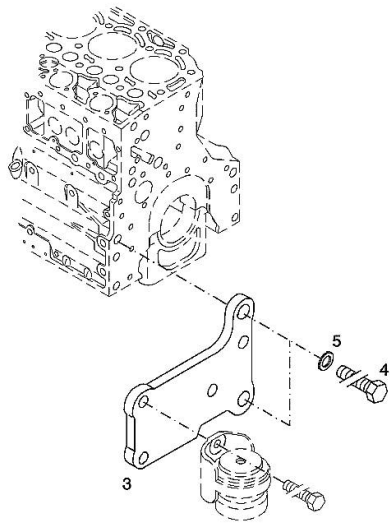
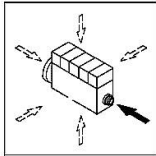

FILLER CAP

Fig.	P/n	QTY	Name
------	-----	-----	------

Notes:
[XM 110 HI-LEVEL]

Engine serial number:
10116591 10191692 10223750 10268967 10285241 10285282 10286560 10299253 10300442 10570548

1	01180286	1	plug H 2875 -B2-OL40-166X4-130X12
---	----------	---	--------------------------------------

000

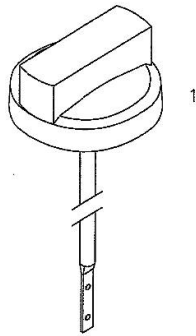

0507 1178

PISTON COOL.NOZZLE

Fig.	P/n	QTY	Name
------	-----	-----	------

Notes:
[XM 110 HI-LEVEL]

Engine serial number:
10116591 10191692 10223750 10268967 10285241 10285282 10286560 10299253 10300442 10570548

1	04207521	1	sprayers
---	----------	---	----------

001 ©

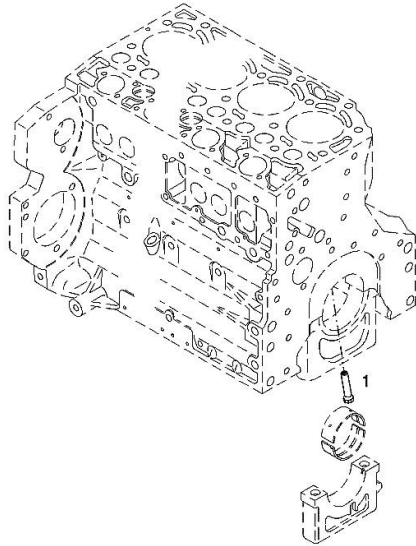
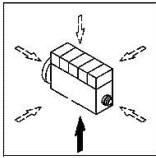

Section: B0 - ENGINE

BLEEDING TUBE

Fig.	P/n	QTY	Name
------	-----	-----	------

Notes:
[XM 110 HI-LEVEL]

Engine serial number:
10116591

2	04198572	1	tube
3	01178750	2	clamp DIN 3021 -A-29X15
4	01167329	1	bottom H 2873 -A24,6X21,5X25-PEWEICH

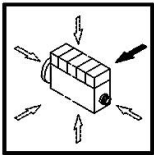

000 ©

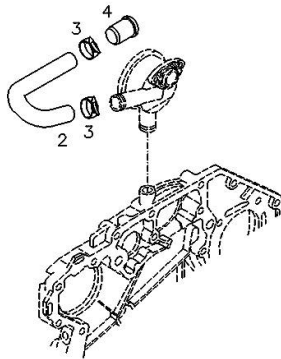

FLANGE

Fig.	P/n	QTY	Name
------	-----	-----	------

Notes:
[XM 110 HI-LEVEL]

1	04502445	1	oil pump WITH POS.... (2,3)
2	04502202	1	special oil seal
3	01133718	8	screw 8.5 Nm DIN 7991 -M6X16-8.8-A4C

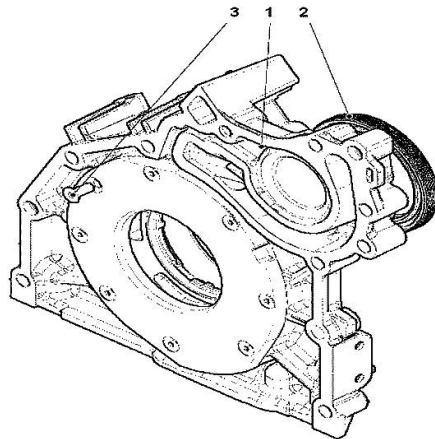

000

FLANGE

Fig.	P/n	QTY	Name
------	-----	-----	------

Notes:
[XM 110 HI-LEVEL]

Engine serial number:
10116591 10191692 10223750 10268967 10285241 10285282 10286560 10299253 10300442 10570548

1	04258382	1	oil pump kpl. WITH POS.... (2,3)
2	04253372	1	oil seal
3	01133718	1	screw DIN 7991 -M6X16-8.8-A4C

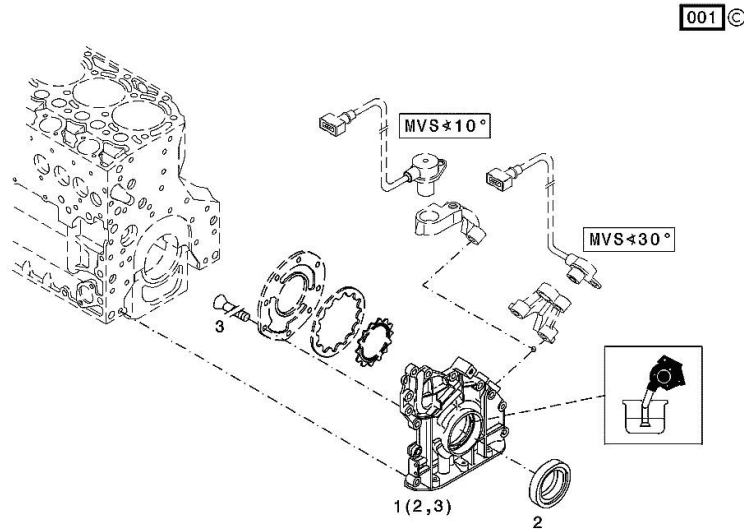
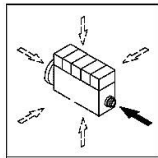

CRANKCASE

Fig.	P/n	QTY	Name
------	-----	-----	------

Notes:
[XM 110 HI-LEVEL]

Engine serial number:
10116591 10191692 10223750 10268967 10285241 10285282 10286560 10299253 10300442

1	04289953	1	crankcase WITH POS.... (2-8.10-17)
2	04254240	14	screw
3	04160764	14	bushing
4	01110423	1	screw DIN 908 -M14X1,5-ST-ZNPHRF
5	01118693	3	gasket 14x20 DIN 7603 -A14X20-CU
6	01180890	1	screw H 2812 -906-M30X1,5-ST-A4C-PRE80
7	01180906	1	screw H 2812 -906-M22X1,5-ST-A4C-PRE80
8	01182031	2	screw H 2812 -906-M14X1,5-ST-A3C-LOCTITE506
10	04251884	6	plug
11	04250086	1	ring
12	01148032	9	cover DIN 443 -A45-ZNPHR
13	01179634	6	plug H 2860 -A36-ST-FE/ZNPHR
14	01100940	2	screw DIN 7604 -AM14X1,5-ST-A4C
15	04202518	1	sleeve
16	04226536	1	bottom
17	04202517	1	sleeve
185	01016125	1	guard H 0699 -DEUTZDW72-250ML

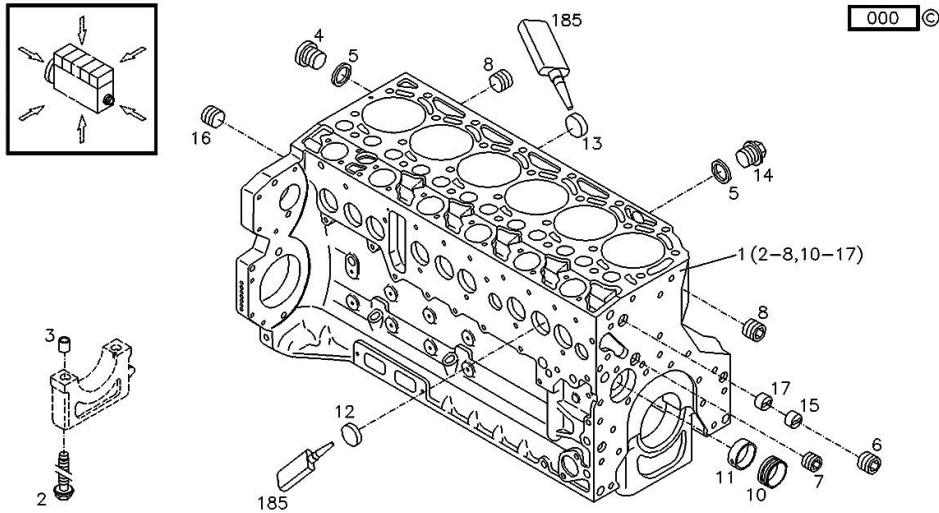

0507 8938

Section: B0 - ENGINE

CRANKCASE

Fig.	P/n	QTY	Name
------	-----	-----	------

Notes:
[XM 110 HI-LEVEL]

Engine serial number:
10570548

1	04296583	1	crankcase WITH POS.... (2-17)
2	04254240	14	screw
3	04160764	14	bushing
4	01110423	1	screw DIN 908 -M14X1,5-ST-ZNPHRF
5	01118693	3	gasket 14x20 DIN 7603 -A14X20-CU
6	01180890	1	screw H 2812 -906-M30X1,5-ST-A4C-PRE80
7	04292706	1	plug
8	01182031	2	screw H 2812 -906-M14X1,5-ST-A3C-LOCTITE506
9	01101342	1	oil seal DIN 7603 -D22X27-CU
10	04251884	6	plug
11	04250086	1	ring
12	01148032	9	cover DIN 443 -A45-ZNPHR
13	01148031	6	plug DIN 443 -A36-ZNPHR
14	01100940	2	screw DIN 7604 -AM14X1,5-ST-A4C
15	04202518	1	sleeve
16	04226536	1	bottom
17	04202517	1	sleeve
185	01016125	1	guard H 0699 -DEUTZDW72-250ML

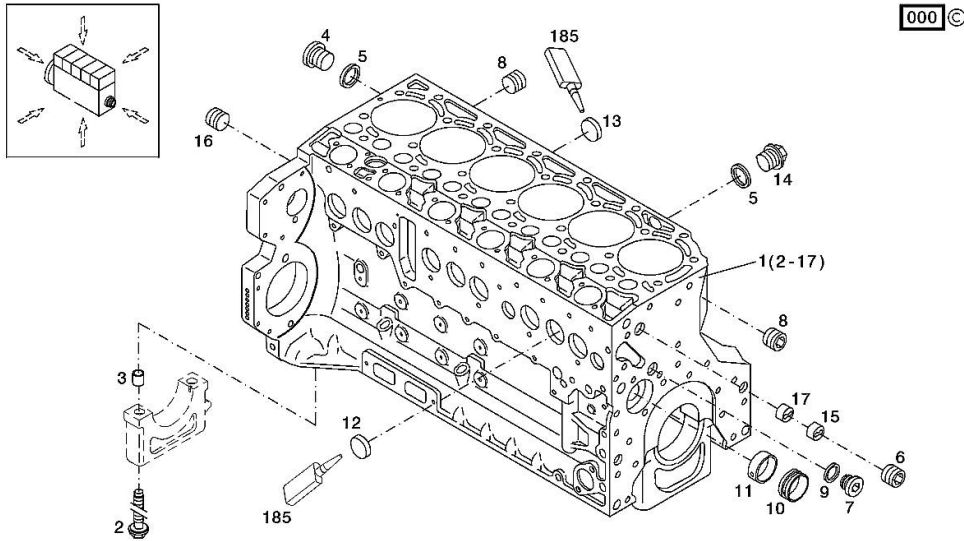

Section: B0 - ENGINE
KURBELGEHAEUSE

Fig.	P/n	QTY	Name
------	-----	-----	------

Notes:
 [XM 110 HI-LEVEL]

185	01319910	1	guard
1	04506847	1	crankcase MIT POS.... (2-17)
2	04254240	14	screw 50 Nm , 90° , 90°
3	04160764	14	bushing
4	01110423	1	screw 35 Nm DIN 908 -M14X1,5-ST-ZNPHRF
5	01118693	3	gasket 14x20 DIN 7603 -A14X20-CU
6	01180890	1	screw 95 Nm H 2812 -906-M30X1,5-ST-A4C-PRE80
7	04292706	1	plug 80 Nm
8	01182031	2	screw 35 Nm H 2812 -906-M14X1,5-ST-A3C-LOCTITE506
9	01101342	1	oil seal DIN 7603 -D22X27-CU
10	04251884	6	plug
11	04250086	1	ring
12	01148032	9	cover DIN 443 -A45-ZNPHR
13	01148031	6	plug DIN 443 -A36-ZNPHR
14	01100940	2	screw 35 Nm DIN 7604 -AM14X1,5-ST-A4C
15	04202518	1	sleeve
16	04226536	1	bottom 30 Nm
17	04202517	1	sleeve

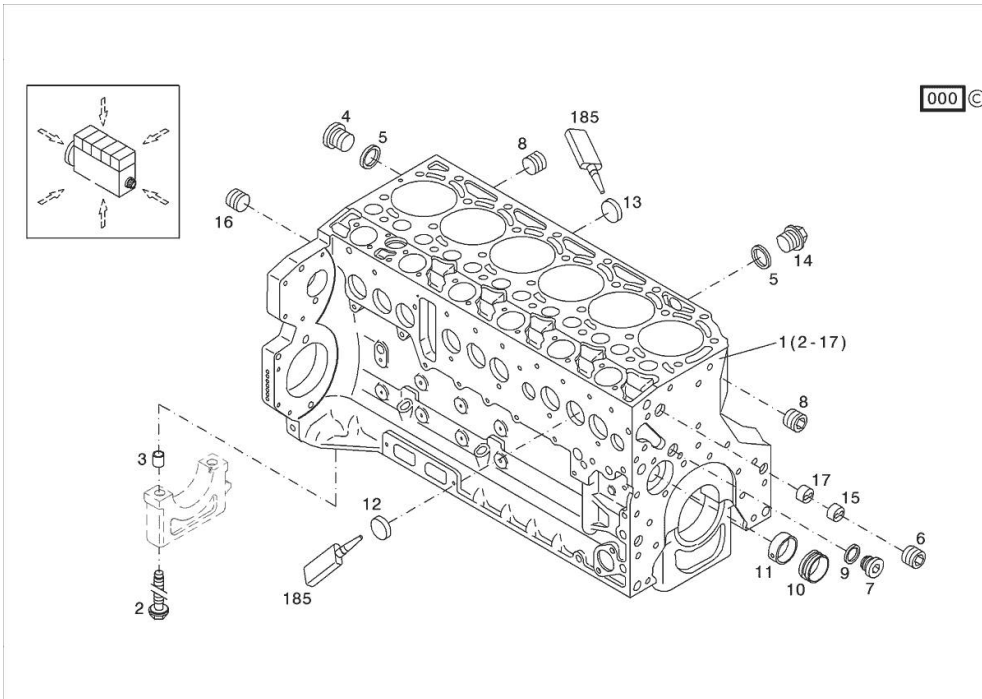

COMPRESSOR BELT AND BELT TENSIONER

Fig.	P/n	QTY	Name
------	-----	-----	------

Notes:

- WITH 2 SOCKETS [XM 110 HI-LEVEL]

15	04454643.4	1	tensioner
16	04454180	1	belt PV-K 14.2x1410 mm

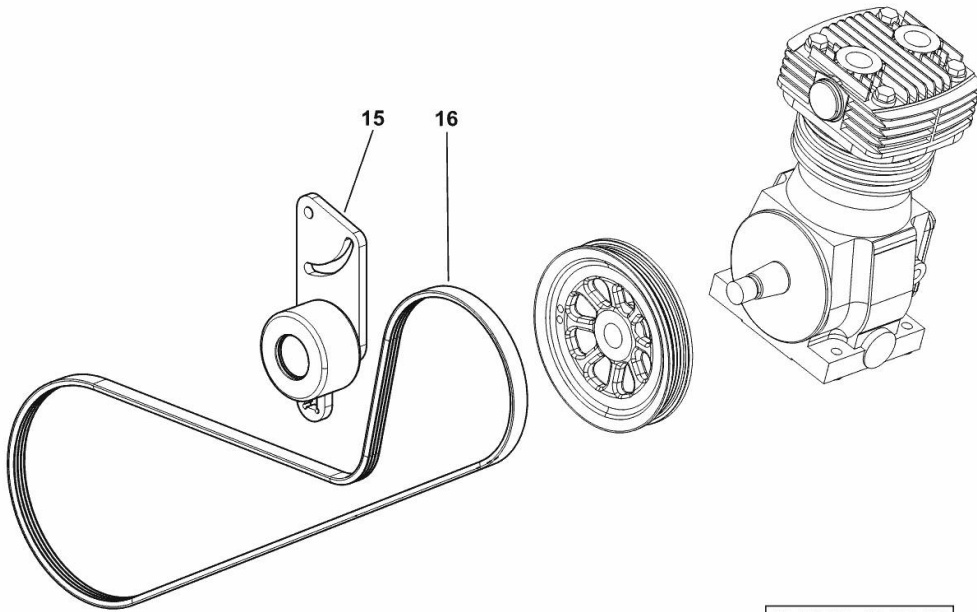

K9_B1889_15_0-B-001

Thank you so much for reading.
Please click the “Buy Now!”
button below to download the
complete manual.



After you pay.

You can download the most
perfect and complete manual in
the world immediately.

Our support email:

ebooklibonline@outlook.com