

REAR AXLE - MOUNTINGS SX/LH/LI - DX/RH/RE

Fig.	P/n	QTY	Name
------	-----	-----	------

Notes:
[XM 110 T4i]

1	2.0422.435.7	8	stud bolt m 12 x 200
2	2.1475.004.7	24	washer 13 x 24
3	2.1011.107.2	14	nut m 12 p.1.75
4	2.0112.444.2	10	screw m 12 p.1.75x180
5	2.0422.434.7	6	stud bolt m 12 p.1.75x190

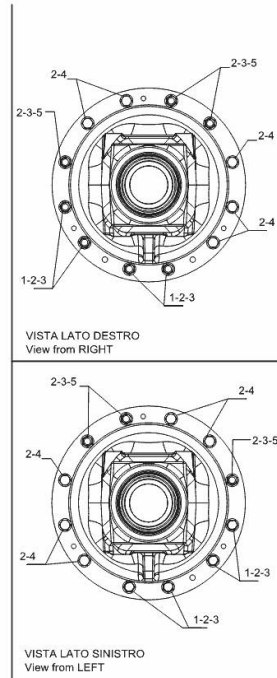
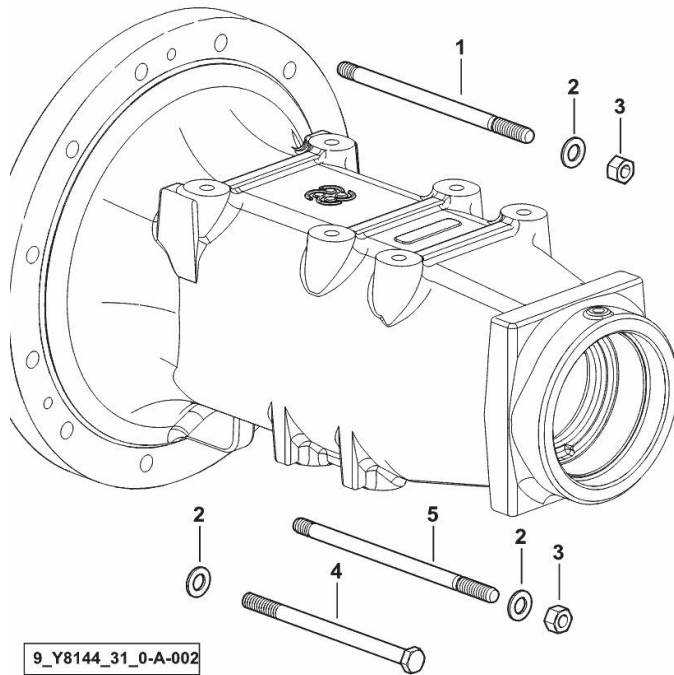

4-PLANET PINION DIFFERENTIAL

Fig.	P/n	QTY	Name
------	-----	-----	------

Notes:

- FOR TYPES WITHOUT SBA / ASM [XM 110 T4i]

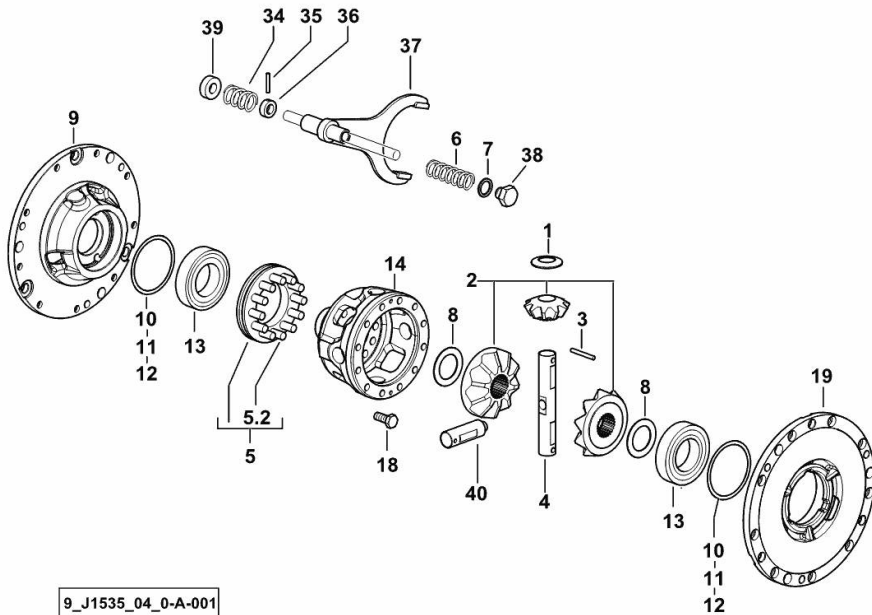

1	0.157.3550.0	4	shoulder ring
2	0.011.7735.3	1	crown wheel
3	2.1631.519.0	2	roll pin 6x50
4	0.010.0614.0/10	1	pin
5	0.135.3527.3/20	1	sleeve
5.2	0.135.3550.0/10	12	pin
6	2.4019.225.1	1	spring 28 x 79 x 4.5
7	2.1560.014.0	1	washer 18.2 x 24
8	2.1599.427.0/10	2	shoulder ring 42x64x0.3
9	0.015.2817.0/20	1	flange dx/rh/re
10	2.1580.319.0	5	shim 86x98x0.5
11	2.1580.320.0	4	shim 86x98x0.2
12	2.1580.321.0	2	shim 86x98x0.05
13	2.2520.012.0	2	roller bearing iso 55 kb 02
14	0.011.7732.0/30	1	differential carrier
18	2.0129.028.2	12	screw m 12 p.1.25x30
19	0.015.2833.0/20	1	flange sx/lh/li
34	2.4019.339.1	1	spring 32x56.5x3.5
35	2.1631.415.2	1	pin 5x32
36	0.190.6858.0	1	spacer 16X28X10
37	0.445.3541.0/30	1	fork
38	2.3110.405.1	1	plug m 18 p.1.5 x 15
39	2.1549.146.0/10	1	spacer 16.5X33X12
40	0.010.0613.0	2	pin

9_J1535_04_0-A-001

4-PLANET PINION DIFFERENTIAL

Fig.	P/n	QTY	Name
------	-----	-----	------

Notes:

- FOR TYPES WITH SBA / ASM [XM 110 T4i]

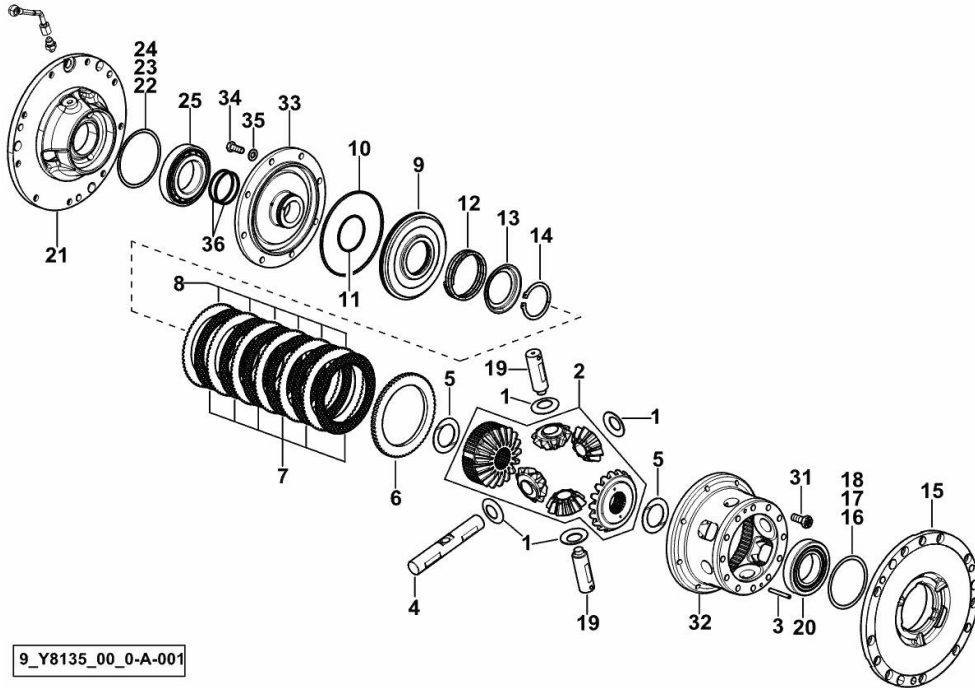

9_Y8135_00_0-A-001

1	0.157.3550.0	4	shoulder ring
2	0.011.7161.3	1	crown wheel
3	2.1631.519.0	2	roll pin 6x50
4	0.010.0614.0/10	1	pin
5	2.1599.427.0/10	2	shoulder ring 42x64x0.3
6	0.008.5908.0	1	spacer
7	0.010.5034.2	6	disc mm 2.50
8	0.010.0711.0	6	disc mm 1.75
9	0.010.4853.0/10	1	piston
10	2.1539.094.0	1	special oil seal 151.99x3.53
11	0.005.8281.0	1	oil seal 61.6x2.62
12	0.008.4346.2	1	spring
13	0.008.4344.0	1	cup
14	2.1410.024.1	1	circlip Ø 60 mm
15	0.015.2833.0/20	1	flange sx/lh/li
16	2.1580.319.0	5	shim 86x98x0.5
17	2.1580.320.0	2	shim 86x98x0.2
18	2.1580.321.0	2	shim 86x98x0.05
19	0.010.0613.0	2	pin
20	2.2520.012.0	1	roller bearing iso 55 kb 02
21	0.015.6692.0/10	1	flange
22	2.1580.305.0	2	shim 97x108x0.2
23	2.1580.306.0	2	shim 97x108x0.5
24	2.1580.312.0	2	shim 97x108x0.05
25	2.2520.013.0	1	roller bearing iso 60 kb 02
31	2.0129.028.2	12	screw m 12 p.1.25x30
32	0.010.0549.0/20	1	differential carrier
33	0.008.5909.3/30	1	cover
34	2.0112.309.2	8	screw m 10 p.1.5 x 25
35	2.1475.003.2	8	washer 10
36	0.164.3646.0	2	piston ring

Section: E0 - REAR AXLE
SEPARATOR 86x98x5

Fig.	P/n	QTY	Name
------	-----	-----	------

Notes:
 [XM 110 T4i]

2	2.1599.543.0	1	spacer 86x98x5
---	--------------	---	----------------

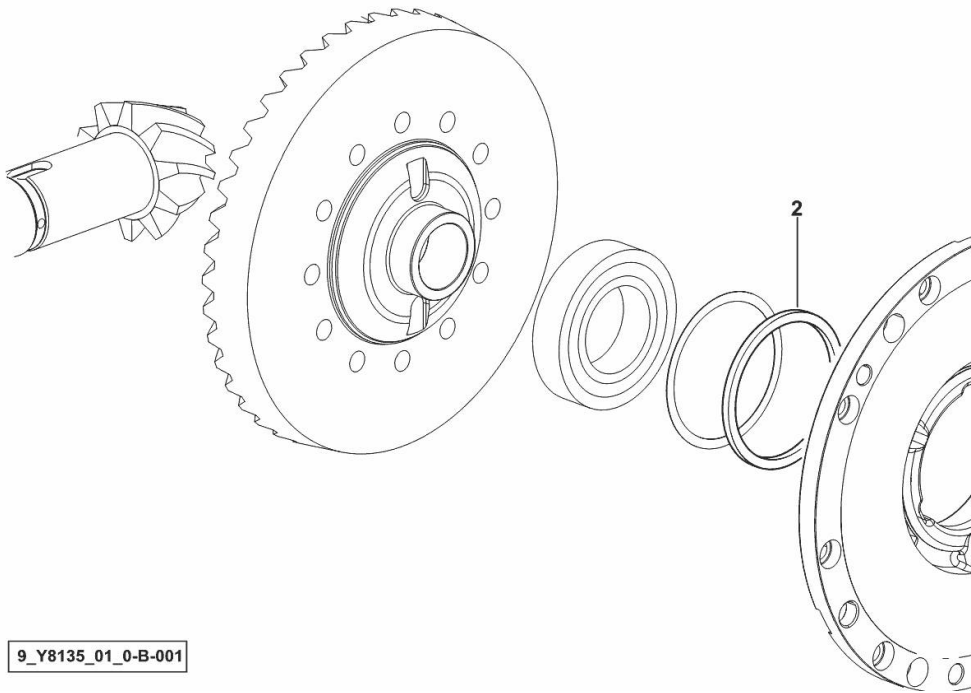

REAR REDUCTION GEARS AND AXLE SHAFTS SX/LH/LI - DX/RH/RE

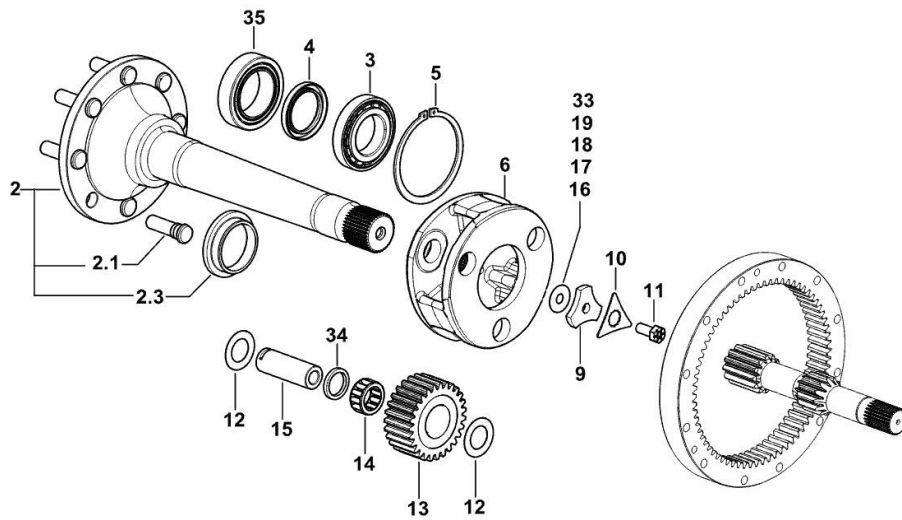

9_J1547_30_0-B-001

Fig.	P/n	QTY	Name
Notes:			
[XM 110 T4i]			
2	0.015.3262.3/10	2	half-shaft
2.1	0.148.4737.0/20	8	small column m 20x68
2.3	0.008.4226.0/10	1	spacer
3	2.2520.013.0	2	roller bearing iso 60 kb 02
4	2.1510.331.0	2	oil seal 60x85x10
5	2.1410.045.1	2	circlip 125
6	0.008.5581.0/10	2	differential carrier
9	0.255.4745.0/10	2	spacer
10	0.008.5605.0	2	washer
11	2.0139.041.1	2	screw m 14 p.1.5 x 33
12	2.1589.170.0	12	shoulder ring 35x58x1
13	0.008.5582.0	6	planet gear
14	2.2999.197.0	6	roller cage
15	0.445.4725.0	6	pin
16	2.1589.106.0	6	shoulder ring 14.5 x 41 x 1.0
17	2.1589.107.0	2	shoulder ring 14.5 x 41 x 0.5
18	2.1589.108.0	2	shoulder ring 14.5 x 41 x 0.2
19	2.1589.109.0	2	shoulder ring 14.5 x 41 x 0.1
33	2.1589.246.0	2	shoulder ring 14.5 x 41 x 0.15
34	2.1549.138.0	6	spacer
35	2.2999.227.0	2	special bearing 70x110x31

HALF AXLES

Fig.	P/n	QTY	Name
------	-----	-----	------

Notes:
[XM 110 T4i]

1	0.015.3705.0/10	1	half-shaft sx/lh/li
2	0.015.3703.0	1	half-shaft dx/rh/re

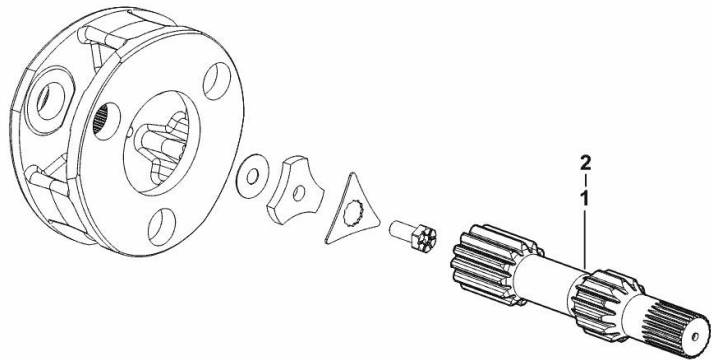

9_J1547_31_0-A-001

DIFFERENTIAL LOCK CONTROL - ELECTROHYDRAUDLIC

Fig.	P/n	QTY	Name
------	-----	-----	------

Notes:
[XM 110 T4i]

1	2.1560.023.0	1	copper gasket 30.3 x 36
2	0.008.5650.0/20	1	piston
3	0.008.5643.0	1	rod
4	0.008.5642.0	1	rod
5	2.3199.245.2/10	1	plug m 30 p.1.5

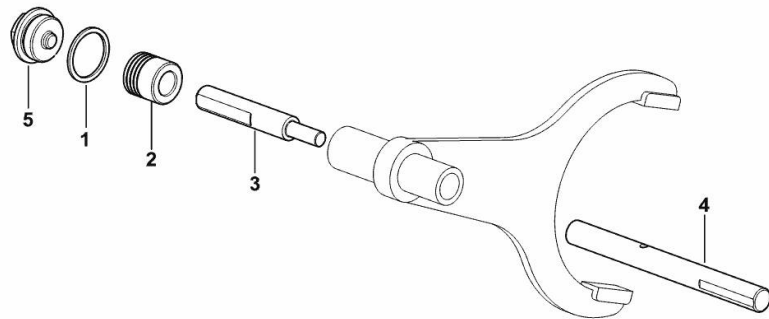

9_J1535_01_0-A-001

REAR WHEEL HUB COVER

Fig.	P/n	QTY	Name
------	-----	-----	------

Notes:
[XM 110 T4i]

1	0.019.4336.3	2	small cover SX/LH/LI - DX/RH/RE
2	0.019.5747.3	2	bracket
3	2.1310.002.2	4	flat washer 6.4x12.5
4	2.0112.005.2	4	screw m 6 p.1 x 16

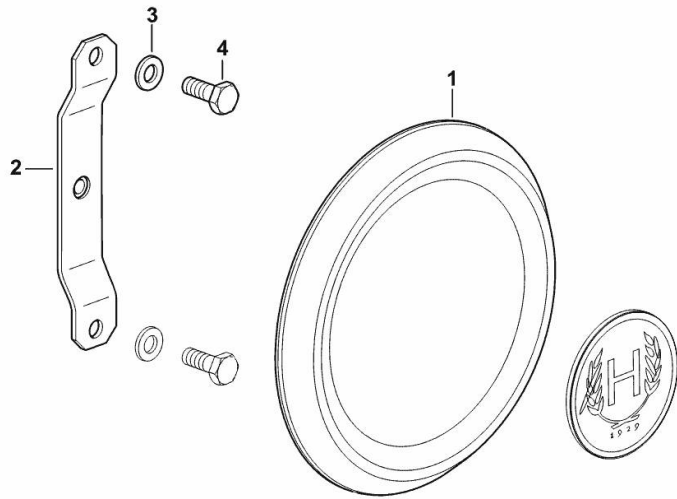

9_Y7147_35_0-B-001

REAR BRAKES WITH 0.35 mm WEAR ADJUSTMENT

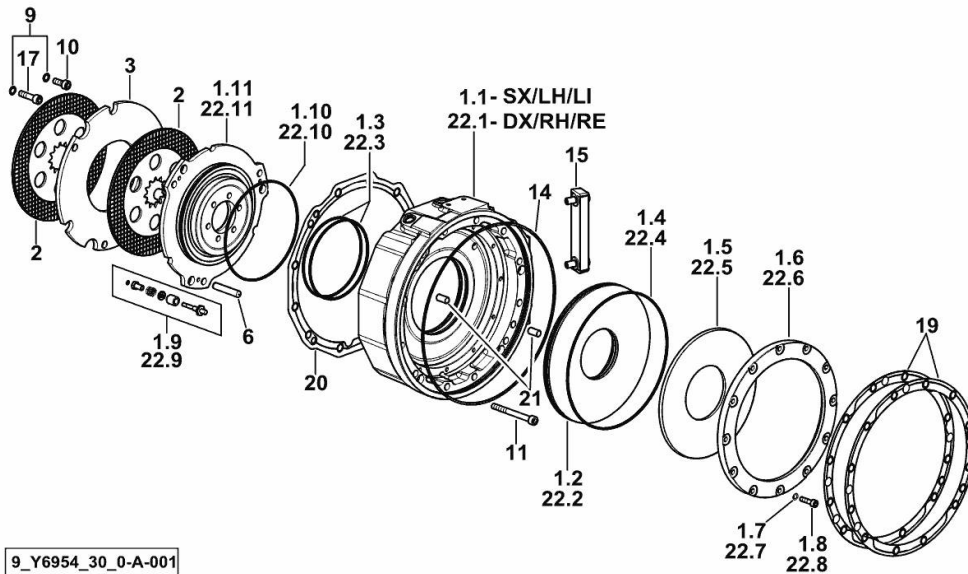

9_Y6954_30_0-A-001

Fig.	P/n	QTY	Name
Notes:			
[XM 110 T4i]			
1.1	0.021.2415.0/20	1	flange SX/LH/LI
1.2	0.018.9211.0	1	piston
1.3	2.1532.253.0	2	oil seal 148.82x3.53
1.4	2.1532.308.0	1	oil seal 253.59x3.53
1.5	2.1499.244.0	1	spring 250x105
1.6	0.015.2815.0/10	1	ring
1.7	2.1480.014.2	12	washer 8
1.8	2.0314.210.2	12	screw m 8 x 30
1.9	0.013.5769.4/60	3	device
1.10	2.1532.279.0	1	oil seal 183.74x3.53
1.11	0.015.2798.0/30	1	piston
2	0.016.3140.2	4	brake disc D=243
3	0.015.2805.0/20	2	spacer
6	2.1655.617.0	6	pin 12x65
9	2.1480.015.2	18	washer 10
10	2.0312.308.2	16	screw m 10 p.1.5 x 25
11	2.0312.326.2	8	screw m 10 p.1.5x100
14	2.1539.518.0	2	special oil seal 343x3.53
15	0.015.8160.0	1	level indicator
17	2.0312.314.2	2	screw m 10 p.1.5 x 40
19	0.017.1697.0/10	4	gasket
20	0.017.2401.0	2	gasket
21	2.1655.608.0	4	pin 12 x 24
22.1	0.019.6746.0/20	1	flange DX/RH/RE
22.2	0.018.9211.0	1	piston
22.3	2.1532.253.0	2	oil seal 148.82x3.53
22.4	2.1532.308.0	1	oil seal 253.59x3.53
22.5	2.1499.244.0	1	spring 250x105
22.6	0.015.2815.0/10	1	ring
22.7	2.1480.014.2	12	washer 8
22.8	2.0314.210.2	12	screw m 8 x 30
22.9	0.013.5769.4/60	3	device
22.10	2.1532.279.0	1	oil seal 183.74x3.53
22.11	0.015.2798.0/30	1	piston

PLUG

Fig.	P/n	QTY	Name
------	-----	-----	------

Notes:
[XM 110 T4i]

1	2.3121.005.2	2	plug m 16 p.1.5
---	--------------	---	-----------------

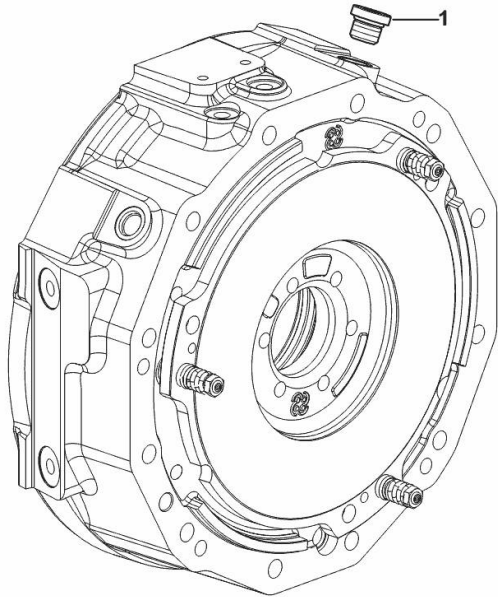

9_L8066_32_0-A-001

FRONT SUPPORT

Fig.	P/n	QTY	Name
------	-----	-----	------

Notes:

- FOR TYPES WITHOUT FRONT PTO AND FRONT LIFT [XM 110 T4i]

1	0.018.9333.0/10	1	front support
2	2.0113.629.2	4	screw m 16 p.2x100
3	2.1475.206.7	8	washer 17x32
5	2.0443.426.7	4	stud bolt m 16 p.1.5x110
6	2.1012.309.7	4	nut m 16 p.1.5
7	0.019.0152.0	2	shim mm 0.1
8	0.019.0154.0	6	shim mm 0.2
9	2.2680.047.0	2	ring 17x22x23
11	0.019.0178.2	1	gasket
12	2.0112.213.2	2	screw m 8 p.1.25 x 35
13	2.1470.004.2	2	lock washer 8
14	2.3199.360.0	12	plug m 14 p.2
15	2.3199.361.0	8	plug m 18 p.2.5
16	2.1312.004.2	2	washer 8x24x2

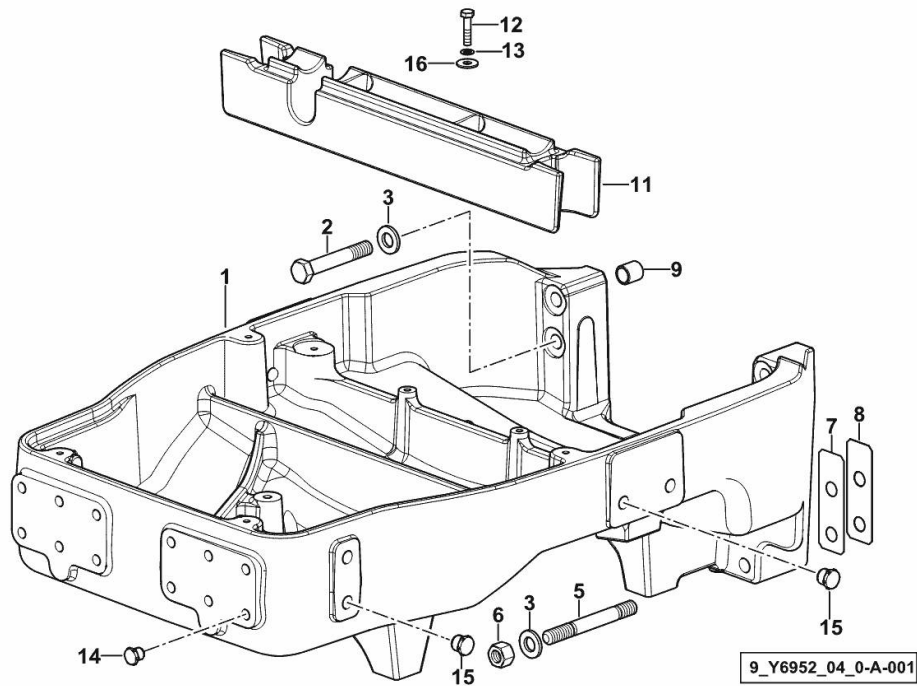

FRONT SUPPORT

Fig.	P/n	QTY	Name
------	-----	-----	------

Notes:

- FOR TYPES W/ OR W/ PROVISION FOR FRONT LIFT/FRONT PTO [XM 110 T4i]

1	0.018.9315.0/20	1	front support
2	2.0113.629.2	4	screw m 16 p.2x100
3	2.1475.206.7	8	washer 17x32
5	2.0443.426.7	4	stud bolt m 16 p.1.5x110
6	2.1012.309.7	4	nut m 16 p.1.5
7	0.019.0152.0	2	shim mm 0.1
8	0.019.0154.0	6	shim mm 0.2
9	2.2680.047.0	2	ring 17x22x23
10	2.1579.820.2	4	spacer 13x25x30
11	0.018.9833.2	1	gasket
12	2.0112.213.2	2	screw m 8 p.1.25 x 35
13	2.1470.004.2	2	lock washer 8
14	2.3199.360.0	12	plug m 14 p.2
15	2.3199.361.0	8	plug m 18 p.2.5
16	2.1312.004.2	2	washer 8x24x2
17	0.020.2981.0	1	dust guard sx/lh/li
18	0.020.2982.0	1	dust guard dx/rh/re

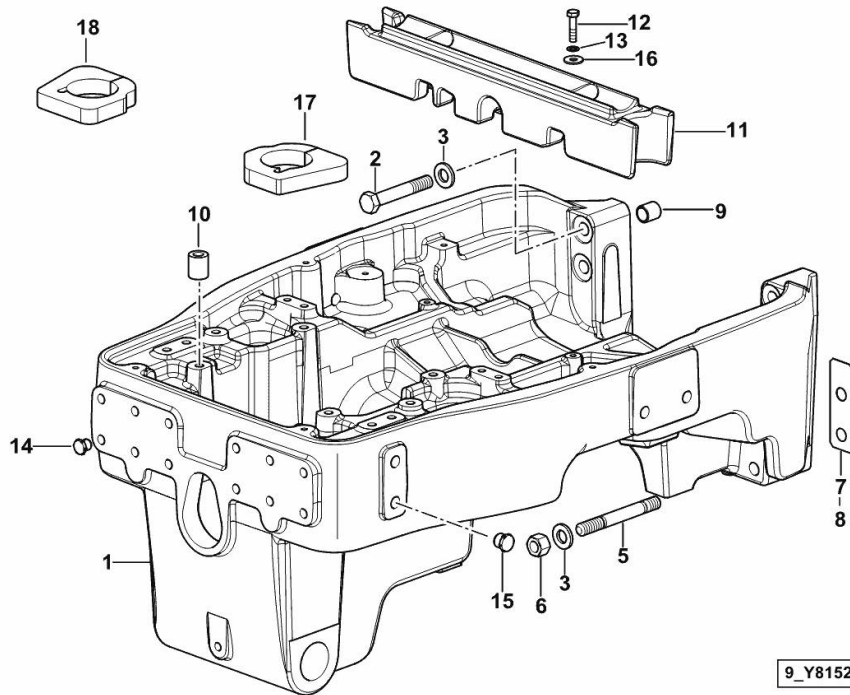

FRONT CARRIER WITH SUSPENSION

Fig.	P/n	QTY	Name
------	-----	-----	------

Notes:

- FOR TYPES W/ OR W/ PROVISION FOR FRONT LIFT/FRONT PTO [XM 110 T4i]

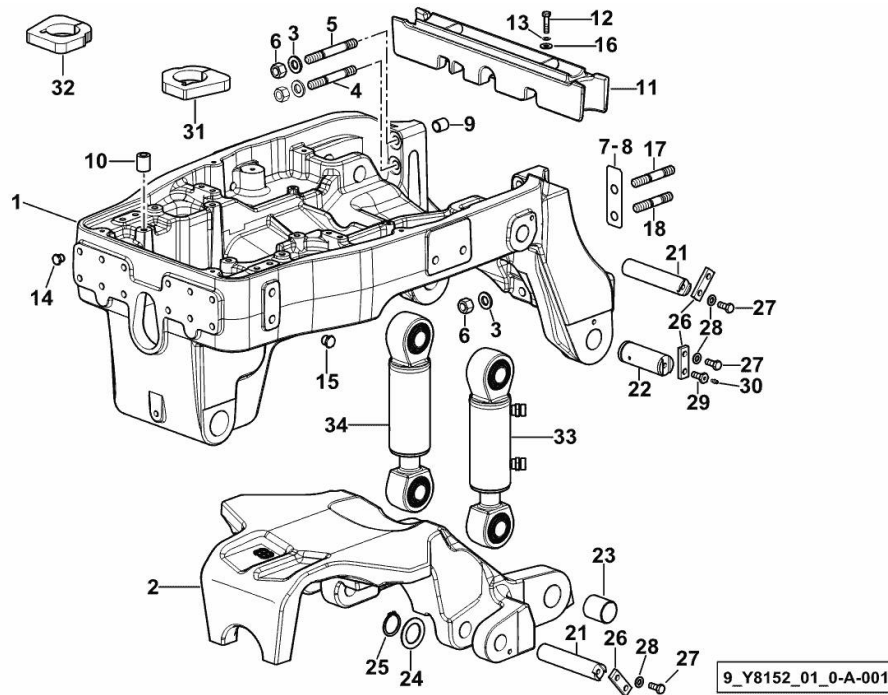

1	0.018.9317.0/20	1	front support
2	0.018.9302.0/10	1	support
3	2.1475.206.7	8	washer 17x32
4	2.0443.423.7	2	stud bolt m 16 p.1.5x90
5	2.0443.425.7	2	stud bolt m 16 p.1.5 x 100
6	2.1012.309.7	8	nut m 16 p.1.5
7	0.019.0152.0	2	shim mm 0.1
8	0.019.0154.0	6	shim mm 0.2
9	2.2680.047.0	2	ring 17x22x23
10	2.1579.820.2	4	spacer 13x25x30
11	0.018.9833.2	1	gasket
12	2.0112.213.2	2	screw m 8 p.1.25 x 35
13	2.1470.004.2	2	lock washer 8
14	2.3199.360.0	12	plug m 14 p.2
15	2.3199.361.0	8	plug m 18 p.2.5
16	2.1312.004.2	2	washer 8x24x2
17	2.0443.420.7	2	stud bolt m 16 p.1.5 x 75
18	2.0443.418.7	2	stud bolt m 16 p.1.5 x 65
21	0.015.3715.0/10	4	pin
22	04438671	2	pin
23	04424134/20	2	bushing
24	04438682	2	ring
25	2.1410.016.7	2	circlip 40x1.75
26	04422768	6	small plate
27	2.0112.309.2	10	screw m 10 p.1.5 x 25
28	2.1310.006.2	10	flat washer 10.5x21
29	04450386/20	2	screw m 10 x 25
30	2.3820.101.2	2	grease gun m 6 p.1 x 5
31	0.020.2981.0	1	dust guard sx/lh/li
32	0.020.2982.0	1	dust guard dx/rh/re
33	2.3749.015.0	1	jack sx/lh/li - Ognibene ☞ 2.3749.015.0
34	2.3749.016.0	1	jack dx/rh/re - Ognibene ☞ 2.3749.016.0

Section: F0 - FRONT AXLE

COMPLETION - WITHOUT FRONT PTO

Fig.	P/n	QTY	Name
------	-----	-----	------

Notes:

- FOR TYPES W/O FRONT LIFT BUT WITH PROVISION FOR FRONT LIFT INSTALLATION [XM 110 T4i] -
 - FOR TYPES WITH SPENDED AXLE AND WITHOUT FRONT LIFT [XM 110 T4i]

3	0.011.0753.2/20	1	plug
4	2.1310.007.2	3	flat washer 13 x 24
5	2.0112.407.2	2	screw m 12 p.1.75 x 20
6	2.3171.019.4	2	plug 50
7	0.019.0338.0/10	1	plug
8	2.1310.009.2	2	flat washer 15x20
9	2.0112.509.2	2	screw m 14 p.1.5x25
10	0.011.2616.2/20	1	shield dx/rh/re
11	2.1310.006.2	2	flat washer 10.5x21
12	2.0112.305.2	2	screw m 10 p.1.5 x 16
15	0.011.2615.2/20	1	shield sx/lh/li
16	0.019.0325.0/20	1	plate
17	2.1470.007.2	4	lock washer 12
18	2.0112.421.2	4	screw m 12 p.1.75 x 60
19	0.019.1504.0/10	1	support
20	2.1470.006.2	4	lock washer 10
21	2.0112.309.2	4	screw m 10 p.1.5 x 25
22	2.0122.459.6	1	screw m 12 p.1.25x25

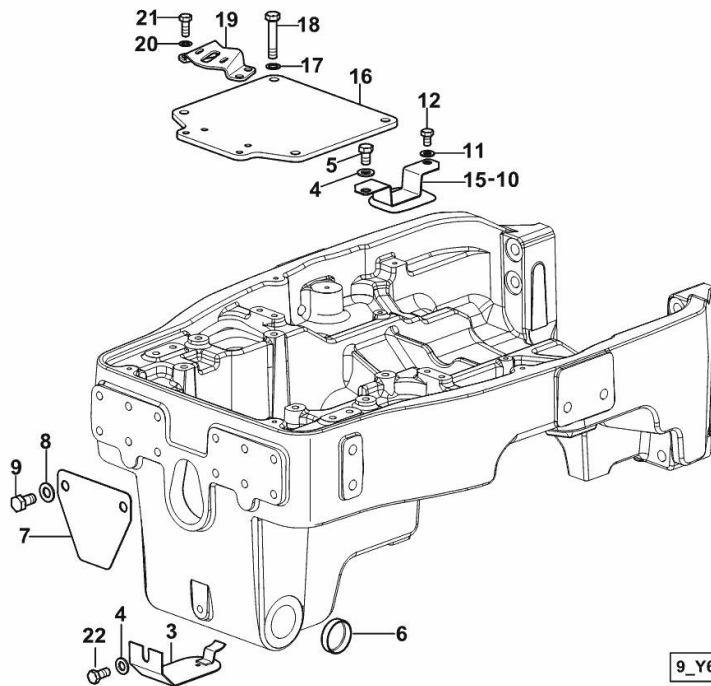

9_Y6952_06_0-A-001

Section: F0 - FRONT AXLE
FRONT SUPPORT PACKAGE

Fig.	P/n	QTY	Name
------	-----	-----	------

Notes:

- FOR TYPES WITHOUT FRONT PTO WITH FRONT LIFT [XM 110 T4i]

1	0.019.0312.3/20	1	cover
2	0.019.1504.0/10	1	support
3	2.1470.006.2	4	lock washer 10
4	2.0112.309.2	4	screw m 10 p.1.5 x 25
5	2.1310.006.2	2	flat washer 10.5x21
6	2.1011.106.2	2	nut m 10 p.1.5
7	2.1470.007.2	4	lock washer 12
8	2.0112.421.2	4	screw m 12 p.1.75 x 60
9	0.154.3655.0/10	1	guard

9_Y4952_06_0-A-001

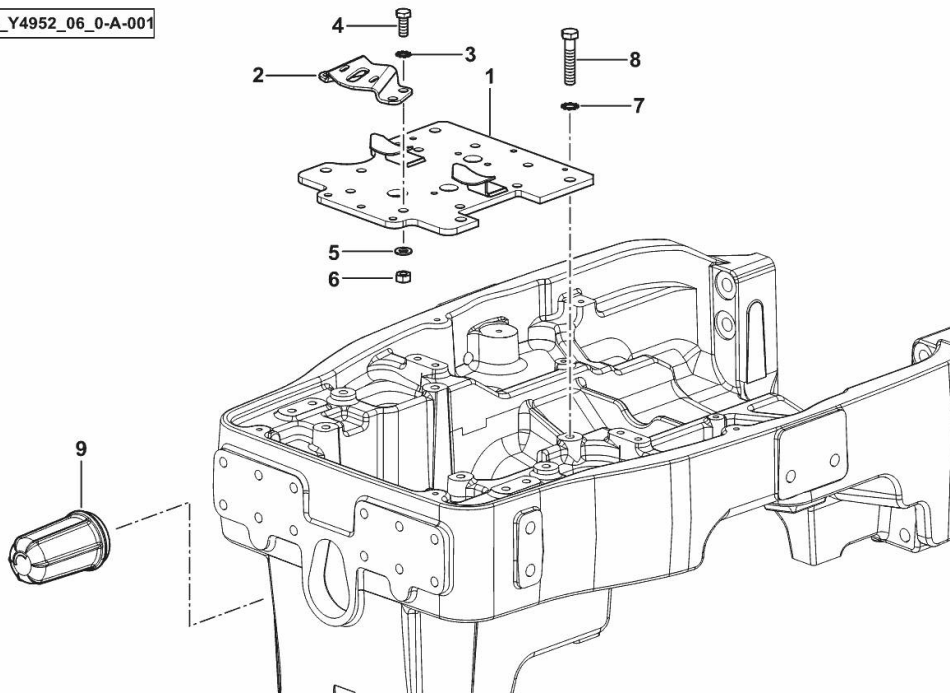

Thank you so much for reading.
Please click the “Buy Now!”
button below to download the
complete manual.



After you pay.

You can download the most
perfect and complete manual in
the world immediately.

Our support email:

ebooklibonline@outlook.com