

**ENGINE**

Fig.	P/n	QTY	Name
------	-----	-----	------

**Notes:**

- EXPORT U.S.A. [XM 90 HI-LEVEL]

1	25006910	1	engine ON ORDERING PLEASE ENGINE NO. REQUIRED
---	----------	---	---

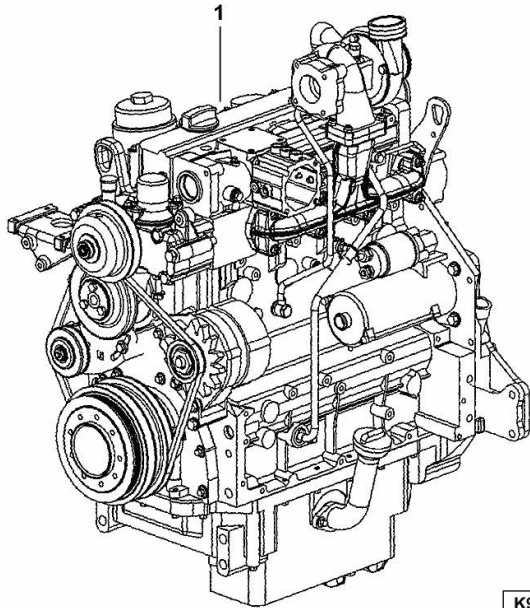

K9\_N7019\_02\_0-A-001

**FASTENINGS**

Fig.	P/n	QTY	Name
------	-----	-----	------

**Notes:**

[XM 90 HI-LEVEL]

1	01183645	12	screw EN 1662 -F-M8X35-10.9-ZNAL-A
2	04504325	1	gasket
3	01181406	1	bushing H 2341 -B11X8-FE/ZN12C*

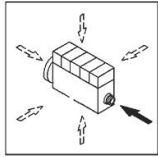

003 ©

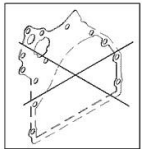
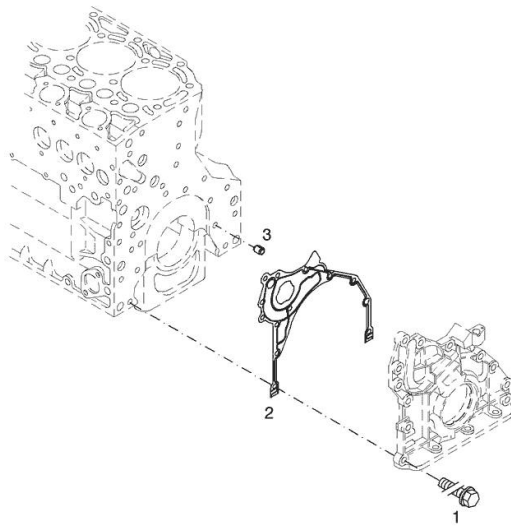

Section: B0 - ENGINE  
**SERIE GUARNIZIONI**

Fig.	P/n	QTY	Name
------	-----	-----	------

Notes:  
 [XM 90 HI-LEVEL]

1	02937585	1	gasket set THE KIT DOES NOT CONTAIN ALL THE GASKETS: SEE SM 0199-99-9449
---	----------	---	--

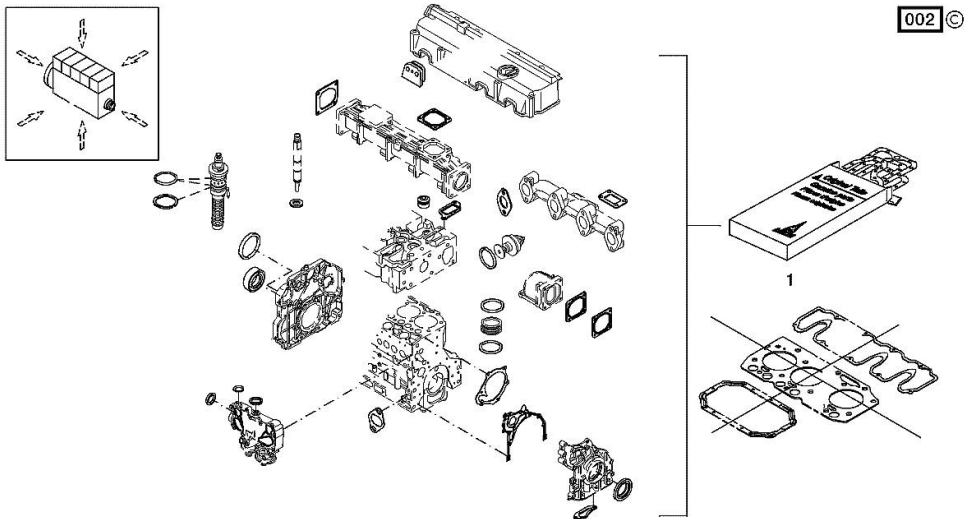

Section: B0 - ENGINE  
**CRANKCASE BREATHER**

Fig.	P/n	QTY	Name
------	-----	-----	------

Notes:  
 [XM 90 HI-LEVEL]

1	04203321	1	valve WITH POS.... (2)
2	04206233	1	gasket
3	01148431	2	screw - FROM THE MONTH OF ASSEMBLY SEE POS. ( B ) - UP TO THE MONTH OF ASSEMBLY ( A ) FROM THE MONTH OF ASSEMBLY A = 09.1995 B = POS. 950 ISO 4762 -M6X20-8.8-ZNAL-A
4	04207290	1	pipng
5	01124654	2	washer 6,4 d433 ISO 7092 -6-140HV-A4C*
950	01181965	2	screw - UP TO MONTH OF ASSEMBLY ( A ) - FROM MONTH OF ASSEMBLY SEE POS. ( B ) A = 08.1995 B = POS. 3 EN 1662 -F-M6X20-10.9-ZNAL-A

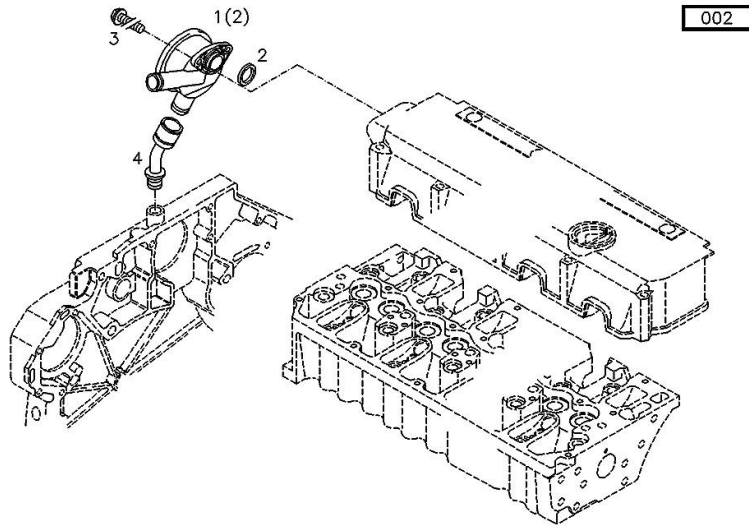
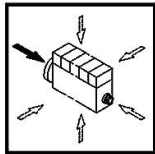

Section: B0 - ENGINE  
**KURBELGEHAEUSE**

Fig.	P/n	QTY	Name
------	-----	-----	------

Notes:  
 [XM 90 HI-LEVEL]

185	01319911	1	sealing compound ml. 50
1	04289939	1	crankcase MIT POS.... (2-15,18-24)
2	04254240	10	screw 50 Nm , 90° , 90°
3	04160764	10	bushing
4	01110423	1	screw 35 Nm DIN 908 -M14X1,5-ST-ZNPHRF
5	01118693	3	gasket 14x20 DIN 7603 -A14X20-CU
6	01180890	1	screw 95 Nm H 2812 -906-M30X1,5-ST-A4C-PRE80
7	01180906	1	screw H 2812 -906-M22X1,5-ST-A4C-PRE80
8	01182031	2	screw 35 Nm H 2812 -906-M14X1,5-ST-A3C-LOCTITE506
10	04251884	4	plug
11	04250086	1	ring
12	01148032	6	cover DIN 443 -A45-ZNPHR
13	01179634	4	plug H 2860 -A36-ST-FE/ZNPHR
14	01100940	2	screw 35 Nm DIN 7604 -AM14X1,5-ST-A4C
15	04202518	1	sleeve
18	04226536	1	bottom 30 Nm
19	04259301	2	shaft
20	04252834	4	bush
21	04251810	2	plug
22	01181672	2	nut H 2091 -4017-M8X16-10.9-GESCHW-MK-1.0
23	04255998	1	ring
24	04254026	1	piping

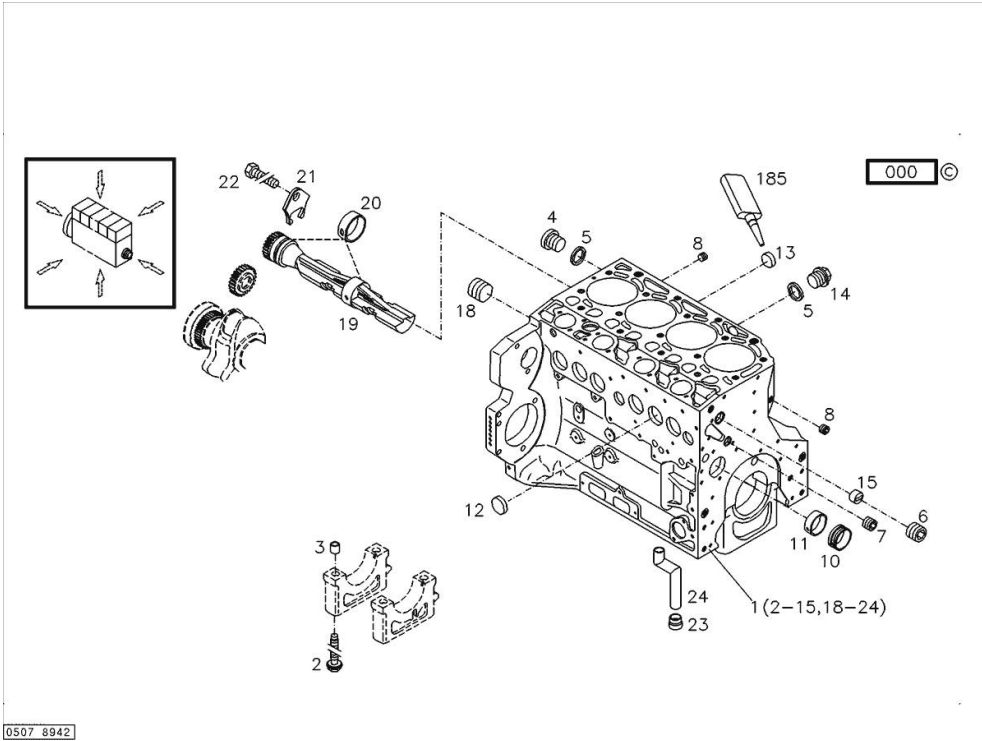

Section: B0 - ENGINE

**ACCESSORIES**

Fig.	P/n	QTY	Name
------	-----	-----	------

**Notes:**

[XM 90 HI-LEVEL]

3	04288659	1	support
4	01148261	2	screw ISO 4017 -M16X40-10.9-ZNAL-A
5	01181400	2	washer H 2308 -18X25X1,5-A4C

006 ©

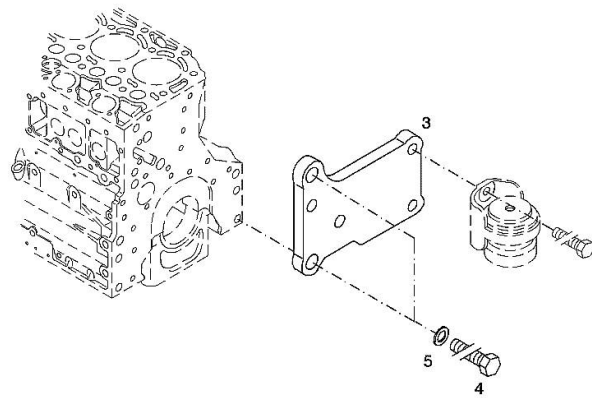
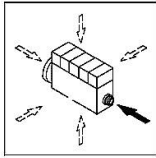

Section: B0 - ENGINE  
**OIL FILLER NECK**

Fig.	P/n	QTY	Name
------	-----	-----	------

Notes:  
 [XM 90 HI-LEVEL]

1	04207099	1	tube
2	01178421	1	gasket
3	01181433	2	screw
			30 Nm

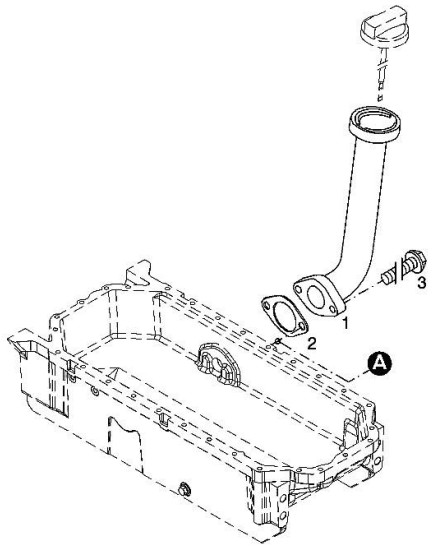
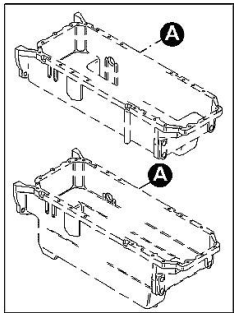
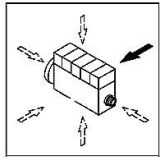

001 ©

**ACCESSORIES**

Fig.	P/n	QTY	Name
------	-----	-----	------

**Notes:**

[XM 90 HI-LEVEL]

3	01182016	2	disc H 2308 -13X24X3-ZNAL-A
4	01181400	2	washer H 2308 -18X25X1,5-A4C
5	04206926	1	plate dx/rh/re
6	04206927	1	plate sx/lh/li
7	01148137	2	screw - UP TO MONTH OF ASSEMBLY ( A ) - FROM MONTH OF ASSEMBLY SEE POS. ( B ) A = 06.2009 B = POS. 950 DIN 931 -M12X75-10.9-ZNAL-A
8	01148037	2	screw UP TO MONTH OF ASSEMBLY ( A ) - FROM MONTH OF ASSEMBLY SEE POS. ( B ) A = 06.2009 B = POS. 951 ISO 4014 -M16X75-10.9-OELGESCHW
950	01149017	2	screw - FROM MONTH OF ASSEMBLY SEE POS. ( B ) - UP TO MONTH OF ASSEMBLY (A) FROM MONTH OF ASSEMBLY A = 07.2009 B = 7 DIN 34800 -BM12X75-10.9-ZNAL-A
951	01180235	2	screw - FROM MONTH OF ASSEMBLY SEE POS. ( B ) - UP TO MONTH OF ASSEMBLY ( A ) FROM MONTH OF ASSEMBLY A = 07.2009 B= Pos.8 H 2032 -HBM16X75-10.9-GESCHW

003 ©

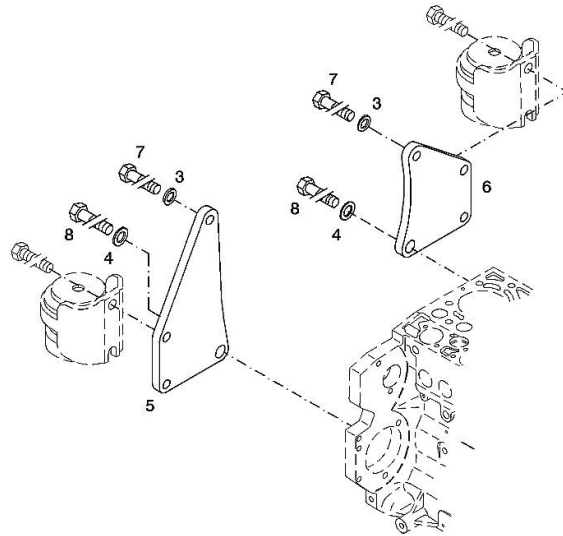
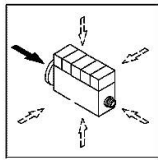



**ACCESSORIES**

Fig.	P/n	QTY	Name
------	-----	-----	------

**Notes:**

[XM 90 HI-LEVEL]

3	04288660	1	support
4	01148261	2	screw ISO 4017 -M16X40-10.9-ZNAL-A
5	01181400	2	washer H 2308 -18X25X1,5-A4C

003 ©

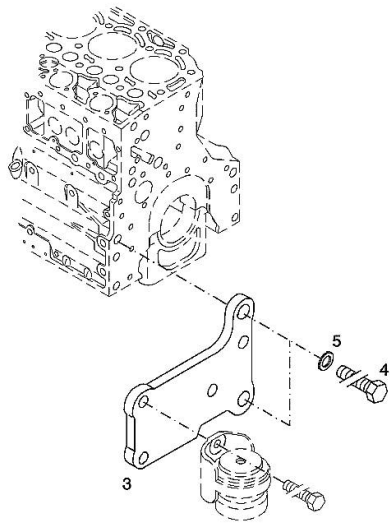
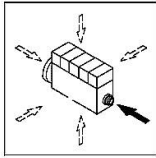

**FILLER CAP**

Fig.	P/n	QTY	Name
------	-----	-----	------

Notes:  
[XM 90 HI-LEVEL]

1	01180286	1	plug H 2875 -B2-OL40-166X4-130X12
---	----------	---	--------------------------------------

000

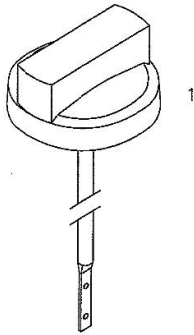

**PISTON COOL.NOZZLE**

Fig.	P/n	QTY	Name
------	-----	-----	------

Notes:  
[XM 90 HI-LEVEL]

1	04207521	1	sprayers
---	----------	---	----------

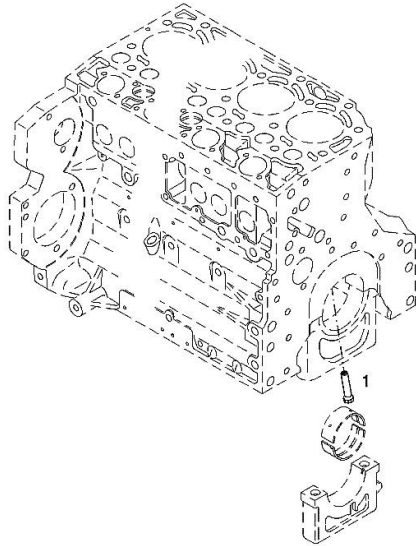
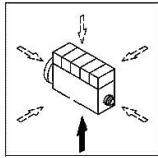

001 ©

**FLANGE**

Fig.	P/n	QTY	Name
------	-----	-----	------

Notes:  
[XM 90 HI-LEVEL]

1	04283992	1	oil pump WITH POS.... (2,3)
2	04253372	1	oil seal
3	01133718	8	screw DIN 7991 -M6X16-8.8-A4C

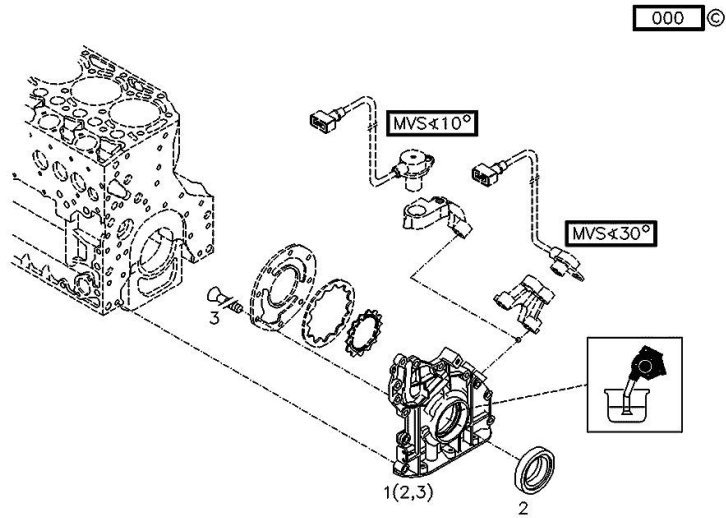
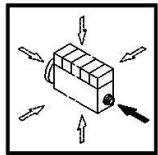

Section: B0 - ENGINE  
**KURBELGEHAEUSE**

Fig.	P/n	QTY	Name
------	-----	-----	------

Notes:  
 [XM 90 HI-LEVEL]

185	01319911	1	sealing compound ml. 50
1	04297344	1	crankcase MIT POS.... (2-15,18-24)
2	04254240	10	screw 50 Nm , 90° , 90°
3	04160764	10	bushing
4	01110423	1	screw 35 Nm DIN 908 -M14X1,5-ST-ZNPHRF
5	01118693	3	gasket 14x20 DIN 7603 -A14X20-CU
6	01180890	1	screw 95 Nm H 2812 -906-M30X1,5-ST-A4C-PRE80
7	04292706	1	plug 80 Nm
8	01182031	2	screw 35 Nm H 2812 -906-M14X1,5-ST-A3C-LOCTITE506
9	01101342	1	oil seal DIN 7603 -D22X27-CU
10	04251884	4	plug
11	04250086	1	ring
12	01148032	6	cover DIN 443 -A45-ZNPHR
13	01148031	4	plug DIN 443 -A36-ZNPHR
14	01100940	2	screw 35 Nm DIN 7604 -AM14X1,5-ST-A4C
15	04202518	1	sleeve
18	04226536	1	bottom 30 Nm
19	04298243	2	shaft
20	04252834	4	bush
21	04251810	2	plug
22	01181672	2	nut H 2091 -4017-M8X16-10.9-GESCHW-MK-1.0
23	04255998	1	ring
24	04291215	1	tube

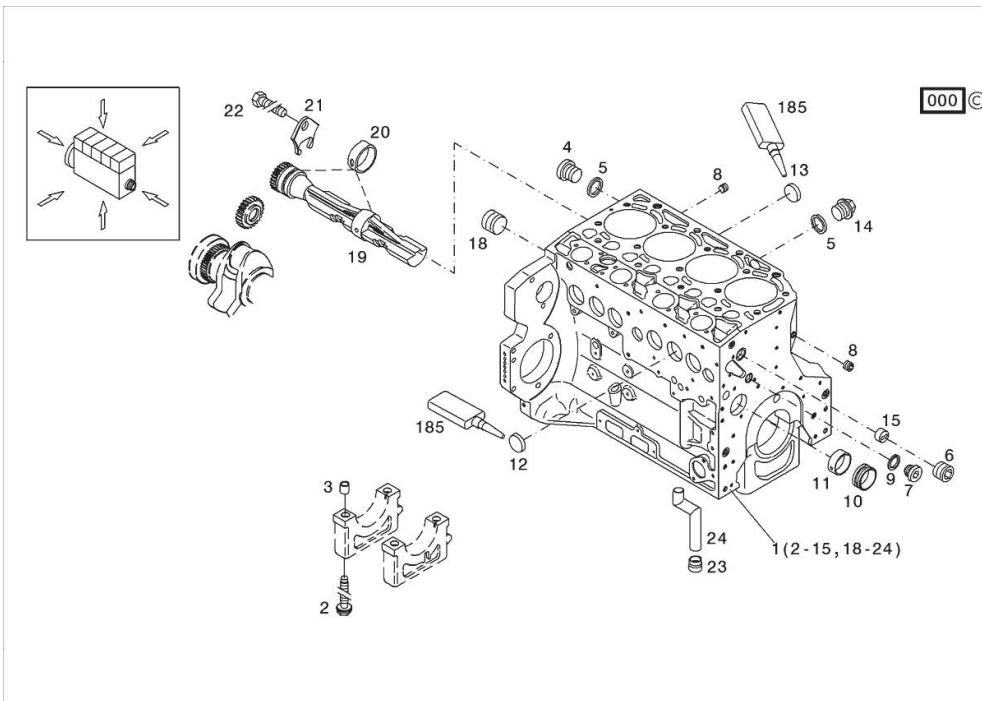

Section: B0 - ENGINE  
**KURBELGEHAEUSE**

Fig.	P/n	QTY	Name
------	-----	-----	------

Notes:  
 [XM 90 HI-LEVEL]

1	04506875	1	crankcase MIT POS... (2-16,19-24)
2	04254240	10	screw 50 Nm , 90° , 90°
3	04160764	10	bushing
4	01110423	1	screw 35 Nm DIN 908 -M14X1,5-ST-ZNPHRF
5	01118693	3	gasket 14x20 DIN 7603 -A14X20-CU
6	01180890	1	screw 95 Nm H 2812 -906-M30X1,5-ST-A4C-PRE80
7	04292706	1	plug 80 Nm
8	01182031	2	screw 35 Nm H 2812 -906-M14X1,5-ST-A3C-LOCTITE506
9	01101342	1	oil seal DIN 7603 -D22X27-CU
10	04251884	4	plug
11	04250086	1	ring
12	01148032	6	cover DIN 443 -A45-ZNPHR
13	01148031	4	plug DIN 443 -A36-ZNPHR
14	01100940	2	screw 35 Nm DIN 7604 -AM14X1,5-ST-A4C
15	04202518	1	sleeve
16	04226536	1	bottom 30 Nm
19	04298243	2	shaft
20	04252834	4	bush
21	04251810	2	plug
22	01181672	2	nut 29 Nm H 2091 -4017-M8X16-10.9-GESCHW-MK-1.0
23	04255998	1	ring
24	04291215	1	tube

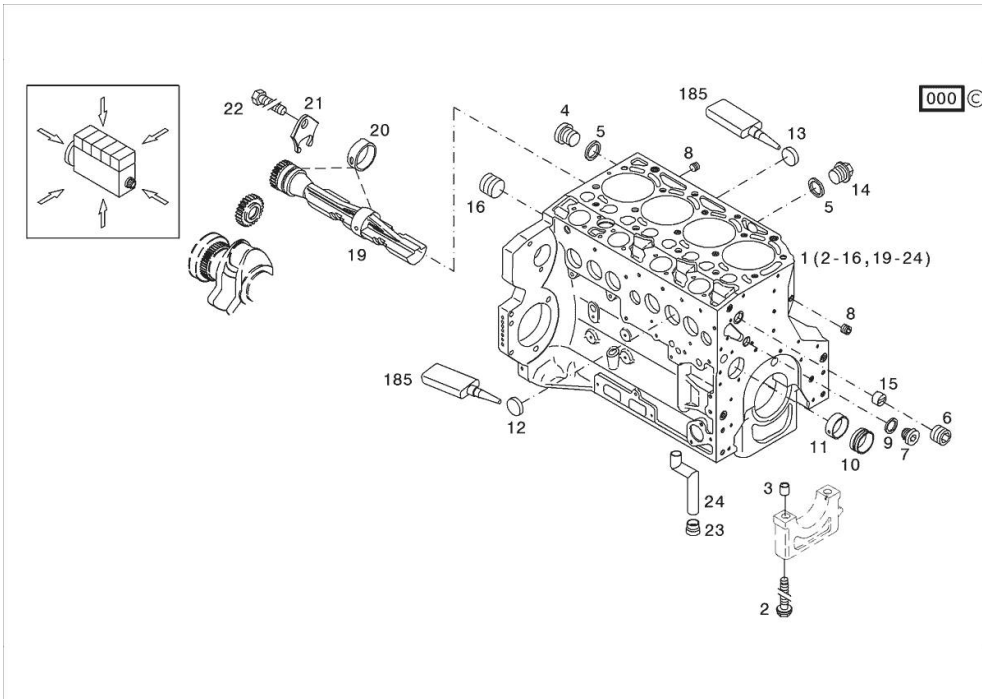

**KURBELGEHAEUSE**

Fig.	P/n	QTY	Name
185	01319911	1	sealing compound ml. 50

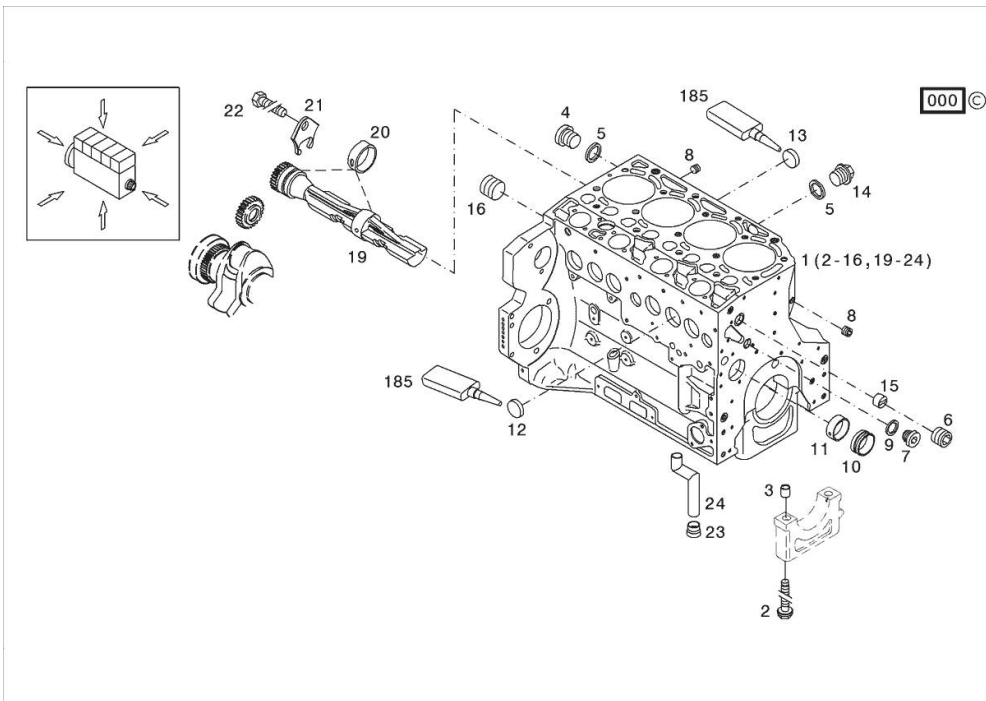

Section: B0 - ENGINE

**BLEEDING TUBE**

Fig.	P/n	QTY	Name
------	-----	-----	------

**Notes:**

[XM 90 HI-LEVEL]

2	04198572	1	tube
3	01178750	2	clamp DIN 3021 -A-29X15
4	01167329	1	bottom H 2873 -A24,6X21,5X25-PEWEICH

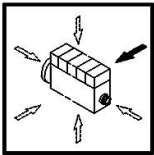

000 ©

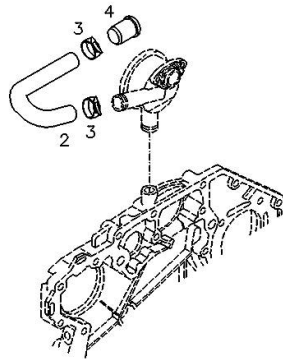



**FLANGE**

Fig.	P/n	QTY	Name
------	-----	-----	------

**Notes:**

[XM 90 HI-LEVEL]

1	04502446	1	oil pump WITH POS.... (2,3)
2	04502202	1	special oil seal
3	01133718	8	screw 8.5 Nm DIN 7991 -M6X16-8.8-A4C

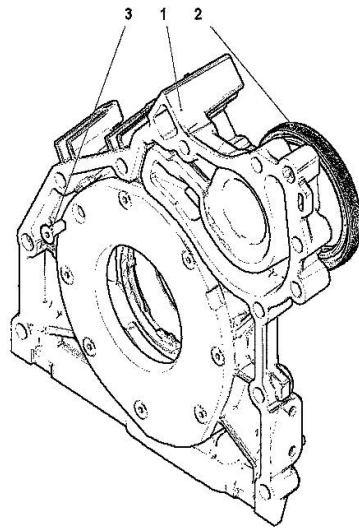

000

**COMPRESSOR BELT AND BELT TENSIONER**

Fig.	P/n	QTY	Name
------	-----	-----	------

**Notes:**

- WITH 2 SOCKETS [XM 90 HI-LEVEL]

15	04454643.4	1	tensioner
16	04454180	1	belt PV-K 14.2x1410 mm

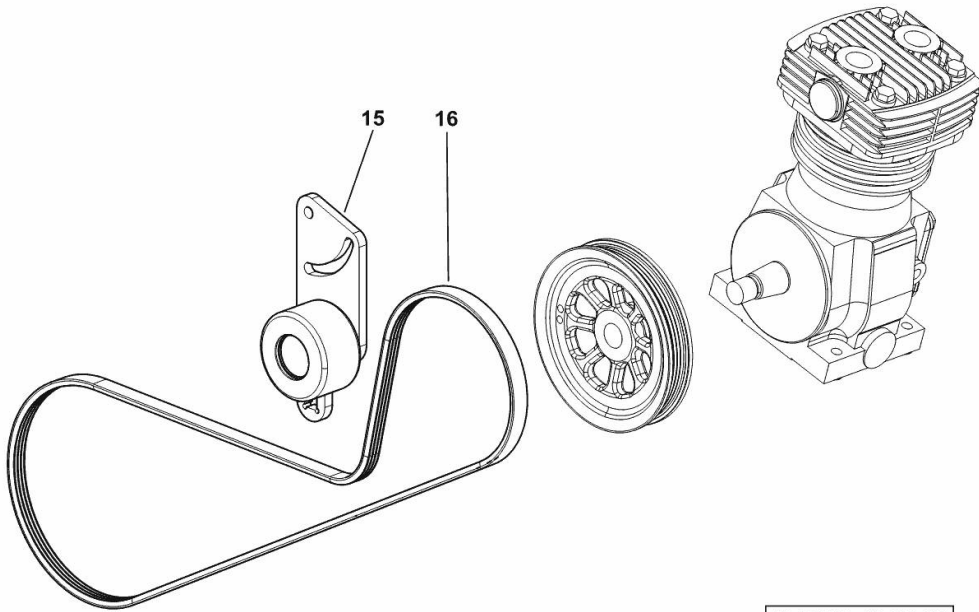

K9\_B3589\_16\_0-B-001

Thank you so much for reading.  
Please click the “Buy Now!”  
button below to download the  
complete manual.



After you pay.

You can download the most  
perfect and complete manual in  
the world immediately.

Our support email:

[ebooklibonline@outlook.com](mailto:ebooklibonline@outlook.com)