

**CRANKCASE**

Fig.	P/n	QTY	Name
------	-----	-----	------

**Notes:**

[XS-90 (20") -> 3001]

3	2.3199.312.2/20	1	plug m 35x1.5x9.5
5	2.0439.273.7	8	stud bolt m 8
6	2.1559.188.2	4	bush 11.4 x 14 x16
7	2.1539.259.0	8	special oil seal 107.62x2.62
8	2.1560.010.0	1	gasket 14.2 x 20
9	2.3199.292.0	1	plug 1/4" gas
11	0.066.1152.0/10	4	gasket
13	2.1549.154.2	4	bush 4.8x5.8x16
14	0.015.2988.4/10	1	crankcase
14.1	2.3130.001.1	10	plug 1/8" gas
14.2	2.3130.002.1	2	plug 1/4" gas
14.3	2.3130.003.1	6	plug 3/8" gas
14.4.1.1.1	0.065.1112.7/10	1	support
14.4.1.2	2.1699.165.0	1	bush 12.3x15x16
14.4.2	0.065.1114.0/10	3	support
14.4.3	0.065.1116.3	1	support
14.4.3.2	2.1699.165.0	1	bush 12.3x15x16
14.4.5	0.065.1117.0	10	screw m 12 x 100
14.5	2.3179.012.0	1	plug 60
14.6	0.065.1140.0	4	special bushing 59X55X20
14.7	0.065.1141.0	1	special bushing 59X55X30
14.8	0.014.1340.0/10	1	pin mm 85
25	0.013.4946.0/10	1	sprayer nozzle
26	2.3120.101.0	1	plug m 18 p.1.5
28	2.1560.014.0	1	washer 18.2 x 24

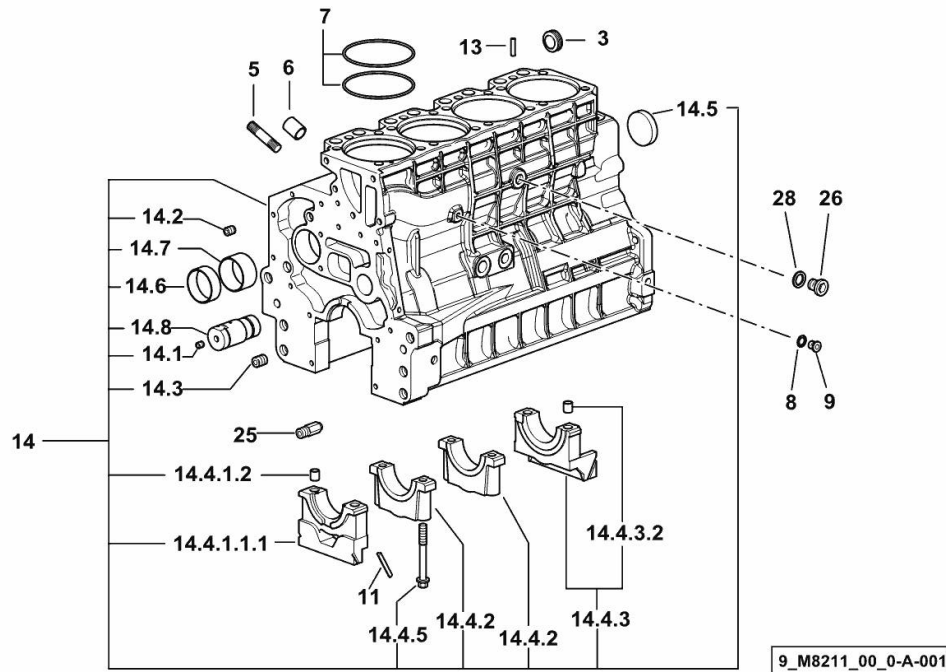

Section: B0 - ENGINE

**CRANKCASE**

Fig.	P/n	QTY	Name
------	-----	-----	------

**Notes:**

- EXPORT U.S.A. [XS-90 (20'') -> 3001]



9\_O1011\_00\_0-A-001

3	2.3199.312.2/20	1	plug m 35x1.5x9.5
5	2.0439.279.7	8	stud bolt m 8 p.1 x 25
6	2.1559.188.2	4	bush 11.4 x 14 x16
7	2.1539.259.0	8	special oil seal 107.62x2.62
8	2.1560.010.0	1	gasket 14.2 x 20
9	2.3199.292.0	1	plug 1/4" gas
10	0.014.9655.4/30	1	crankcase
10.1	2.3130.001.1	14	plug 1/8" gas
10.2	2.3130.002.1	4	plug 1/4" gas
10.3	2.3130.003.1	6	plug 3/8" gas
10.4.1.1.1	0.065.1112.7/10	1	support
10.4.1.2	2.1699.165.0	1	bush 12.3x15x16
10.4.2	0.065.1114.0/10	3	support
10.4.3	0.065.1116.3	1	support
10.4.3.2	2.1699.165.0	1	bush 12.3x15x16
10.4.8	0.065.1117.0	10	screw m 12 x 100
10.5	2.3179.012.0	1	plug 60
10.6	0.065.1140.0	4	special bushing 59X55X20
10.7	0.065.1141.0	1	special bushing 59X55X30
10.8	0.014.1340.0/10	1	pin mm 85
11	0.066.1152.0/10	4	gasket
13	2.1549.154.2	4	bush 4.8x5.8x16
25	0.013.4946.0/10	1	sprayer nozzle
26	2.3120.101.0	1	plug m 18 p.1.5
28	2.1560.014.0	1	washer 18.2 x 24

**MONOBLOC ENGINE-GEARBOX CONNECTING FLANGE**

Fig.	P/n	QTY	Name
------	-----	-----	------

**Notes:**

[XS-90 (20'') -> 3001]

1	0.007.1882.0/50	1	flange
2	2.0112.511.2	8	screw m 14 p.2 x 30
3	2.1651.912.0	2	cylindrical plug 12x28
4	2.1651.917.0	1	cylindrical plug 12x40
5	2.0432.257.7	1	stud bolt m 12 p.1.75 - 1.25 x 30
6	2.0439.250.7	1	stud bolt m 12 / m 10 x 30
7	0.011.9294.0/10	1	bush

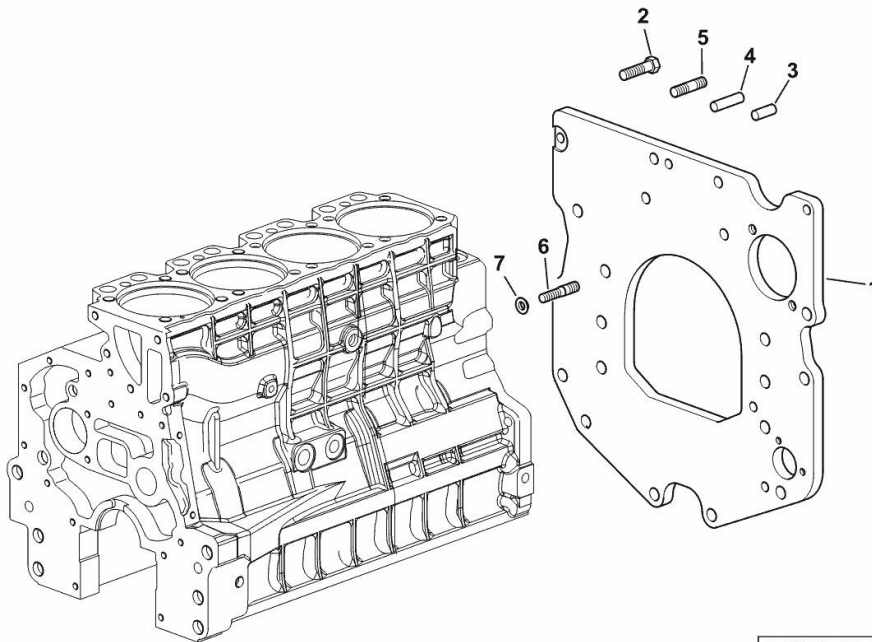

9\_38611\_01\_0-A-001

**ENGINE OIL AND TURBO PRESSURE SWITCH UNION**

Fig.	P/n	QTY	Name
------	-----	-----	------

**Notes:**

[XS-90 (20") -> 3001]

10	2.3339.787.0/10	1	pipe fitting 7/16"
11	2.3110.403.1	1	plug m 14 p.1.5x12
12	2.1560.010.0	2	gasket 14.2 x 20
13	2.1019.129.2/10	1	nut m 18 p.1.5x12
14	2.1533.038.0	1	oil seal 15.45x2.62

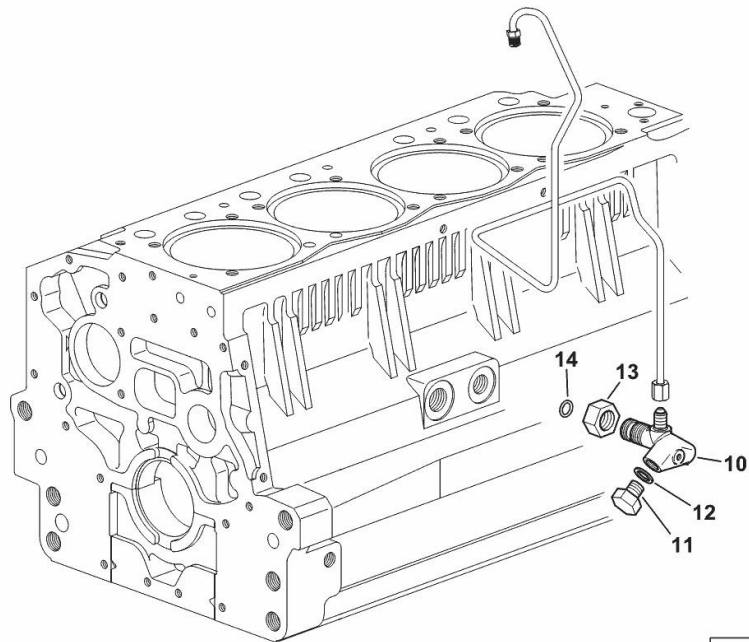

9\_36615\_01\_0-B-001

**PLUG**

Fig.	P/n	QTY	Name
------	-----	-----	------

**Notes:**

[XS-90 (20'') -> 3001]

1	2.3130.003.1	1	plug 3/8" gas
---	--------------	---	---------------

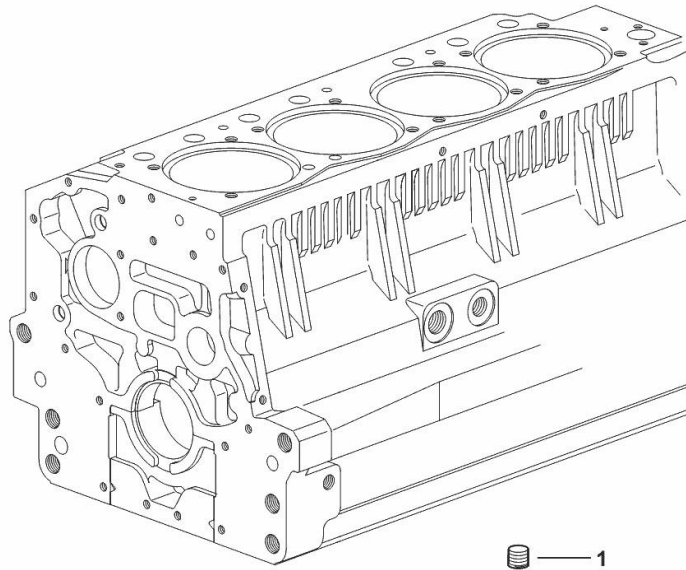

9\_34311\_06\_0-A-001

Section: B0 - ENGINE

**CRANKSHAFT**

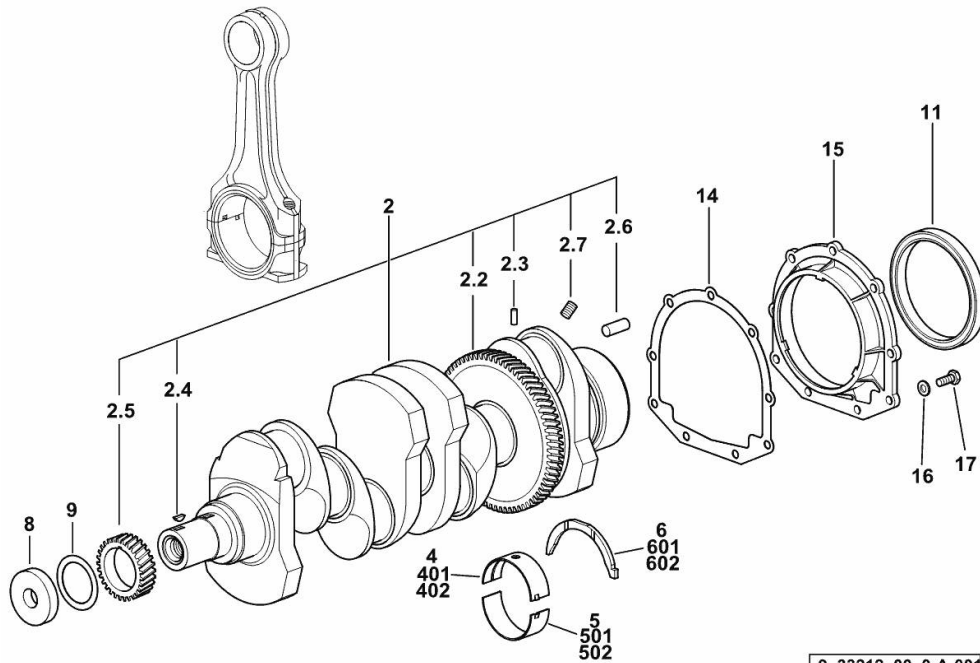

9\_33212\_00\_0-A-001

Fig.	P/n	QTY	Name
------	-----	-----	------

**Notes:**

[XS-90 (20") -> 3001]

2	0.086.1210.3/40	1	crankshaft
2.2	0.065.1211.0/10	1	crown wheel
2.3	2.1630.608.0	1	pin 6x16
2.4	2.1720.006.0	1	key 4x6.5
2.5	0.065.1323.0/30	1	gear Z = 29
2.6	2.1651.915.0	1	pin 12x35
2.7	2.3130.001.1	4	plug 1/8" gas
4	0.065.1215.0/10	5	main half bushing STANDARD
5	0.065.1216.0/10	5	main half bushing STANDARD
6	0.065.1218.0	4	shim STANDARD
8	2.1599.524.7	1	washer 21x60x12
9	2.1589.189.0	2	shoulder ring mm 1.00
11	2.1529.073.0	1	special oil seal 110x130x13
14	0.065.1254.0/20	1	gasket
15	0.007.1711.0/10	1	cover
16	2.1475.002.2	9	conical washer 8
17	2.0112.207.2	9	screw m 8 p 1.25 x 20
401	0.065.1215.7		main half bushing - mm 0.25
402	0.065.1215.8		main half bushing - mm 0.50
501	0.065.1216.7		main half bushing - mm 0.25
502	0.065.1216.8		main half bushing - mm 0.50
601	0.065.1218.7		shim + mm 0.10
602	0.065.1218.8		shim + mm 0.15

Section: B0 - ENGINE

**CRANKSHAFT PULLEY**

Fig.	P/n	QTY	Name
------	-----	-----	------

**Notes:**

[XS-90 (20") -> 3001]

1	0.013.6349.0/10	1	pulley
2	0.011.3515.0/20	1	hub Z = 48
3	0.065.1256.0	2	ring 45x52
4	2.1579.865.0	1	spacer 45.2x51.8x10
5	2.0439.195.7	1	stud bolt m 20 p.1.5x80
6	2.1019.094.7	1	nut m 20 p.1.5
7	2.0112.320.2	6	screw m 10 p.1.5 x 55
8	2.1470.006.2	6	lock washer 10

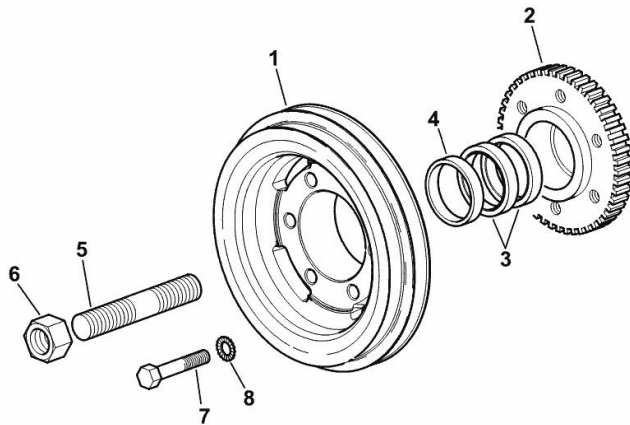

9\_N1412\_03\_0-A-001

Section: B0 - ENGINE  
**ENGINE FLYWHEEL**

Fig.	P/n	QTY	Name
------	-----	-----	------

**Notes:**

[XS-90 (20") -> 3001]

1	0.014.2693.3	1	flywheel
1.2	0.065.1242.0	1	crown wheel Z = 123
2	2.0139.036.2	6	screw m 12 p.1.25 x 35

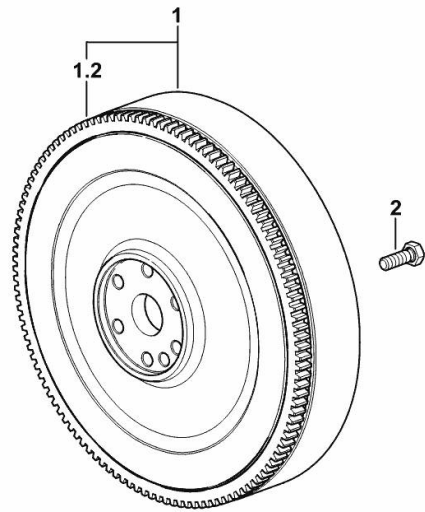

9\_N1312\_02\_0-A-001



Section: B0 - ENGINE  
**COUNTERWEIGHTS**

Fig.	P/n	QTY	Name
------	-----	-----	------

**Notes:**

[XS-90 (20") -> 3001]

25	2.1589.139.0	1	shoulder ring mm 0.3
26	2.1589.140.0	3	shoulder ring mm 0.1
29	2.1579.628.0	3	spacer 16.5x26x0.1
33	2.1579.629.0	6	spacer 12.5x26x0.1
34	2.1589.048.0	1	shoulder ring 16.5x26x0.3
35	2.1589.049.0	1	shoulder ring 12.5x26x0.3
38.1.1	0.086.1231.0/10	1	box
38.1.2	2.3130.001.1	4	plug 1/8" gas
38.2	0.086.1233.3/30	1	mass sx/lh/li
38.2.2	2.1559.115.0	2	special bushing 26x30x30
38.2.99.4	2.1651.302.0	1	roll pin 4x6
38.3	0.065.1233.3/30	1	mass dx/rh/re
38.3.2	2.1559.115.0	2	special bushing 26x30x30
38.3.99.4	2.1651.302.0	1	roll pin 4x6
38.3.99.5	2.1410.018.7	1	circlip 45
38.4.1	0.065.1234.0/10	1	shaft
38.4.2	2.3130.001.1	1	plug 1/8" gas
38.5	2.1631.717.0	2	roll pin 8 x 40
38.6	2.1589.185.0	4	shoulder ring 26.1x34x1
38.7	2.0522.212.7	1	screw m 8 p.1.25 x 30
44	2.1579.626.0	2	spacer 13.2x16x11
45	2.0139.028.2	4	screw m 12
46	2.1699.191.0	1	bush 7x10x16

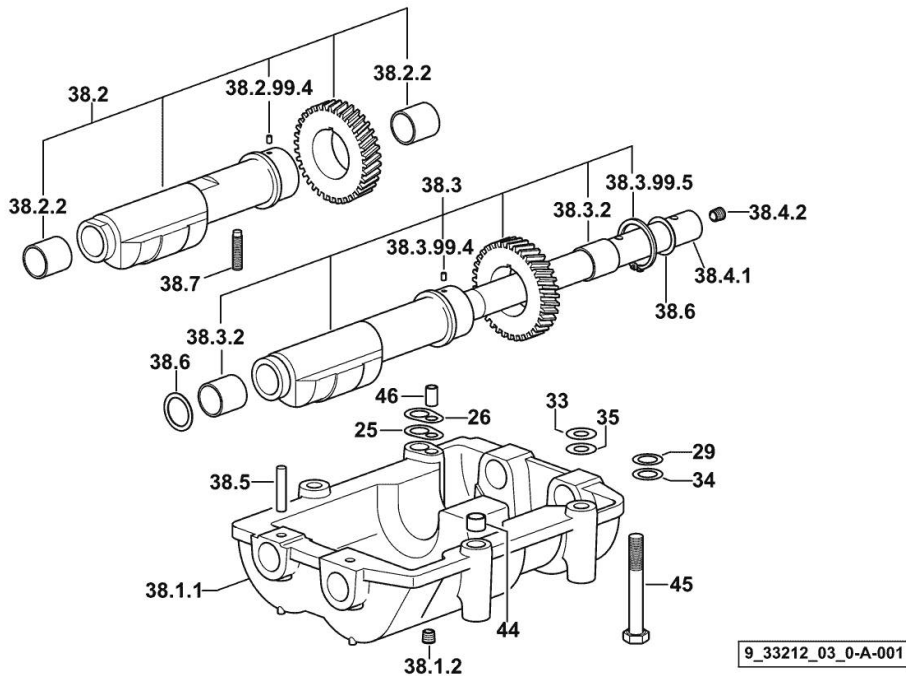

**COOLANT PUMP AND ALTERNATOR DRIVEBELT**

Fig.	P/n	QTY	Name
------	-----	-----	------

**Notes:**

- FOR TRACTORS WITHOUT AIR CONDITIONING [XS-90 (20") -> 3001]

1	2.4119.190.0/10	1	belt AV 12.7x1240 mm
---	-----------------	---	----------------------

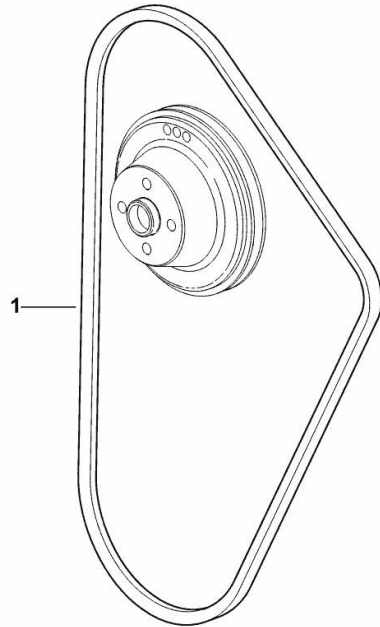

9\_N1517\_02\_0-A-001

**COOLANT PUMP AND ALTERNATOR DRIVEBELT**

Fig.	P/n	QTY	Name
------	-----	-----	------

**Notes:**

- FOR TRACTORS WITH AIR CONDITIONING [XS-90 (20") -> 3001]

1	2.4119.190.0/10	1	belt AV 12.7x1240 mm
2	2.4119.143.0	1	belt AV 12.7x1225 mm

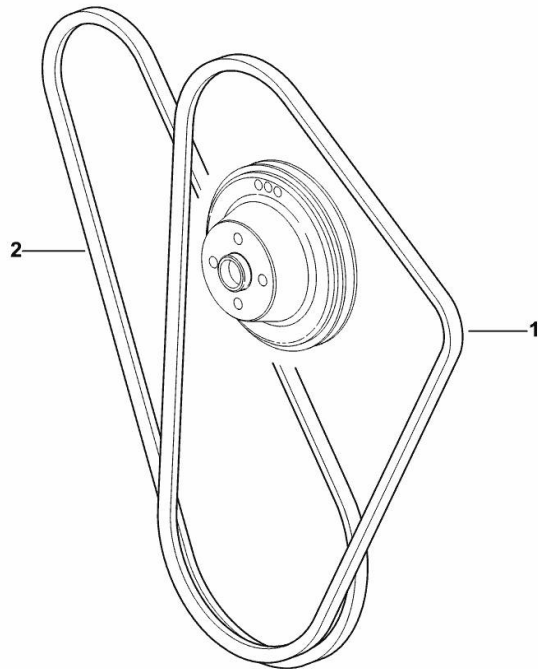

9\_N1517\_04\_0-A-001

**CYLINDER - PISTON - CONNECTING ROD**

Fig.	P/n	QTY	Name
------	-----	-----	------

**Notes:**

[XS-90 (20") -> 3001]

1	0.099.0065.A	4	cyl. piston assembly "A" - CLASS A
1	0.099.0065.B	4	cyl. piston assembly "B" - CLASS B
1.2	0.A12.2675.0	1	engine cylinder "A" - CLASS A
1.2	0.B12.2675.0	1	engine cylinder "B" - CLASS B
1.3	0.099.0060.A	1	complete piston "A" - CLASS A
1.3	0.099.0060.B	1	complete piston "B" - CLASS B
1.3.1	0.081.0090.6/10	1	piston ring set
1.3.2	2.1411.014.1	2	circlip 35
1.3.3	0.078.1236.0	1	piston pin Ø 18 / Ø 35 / L = mm 86
2	0.078.1220.3/30	4	engine connecting rod
2.1	2.1559.114.0/10	1	special bushing
2.2	2.0399.213.0	2	screw m 12 p.1.25x61.5
3	0.065.1225.0	8	con.rod half bushing STANDARD - A = 28.75 -> 29.00
3	0.065.1225.7	8	con.rod half bushing - mm 0.25
3	0.065.1225.8	8	con.rod half bushing - mm 0.50

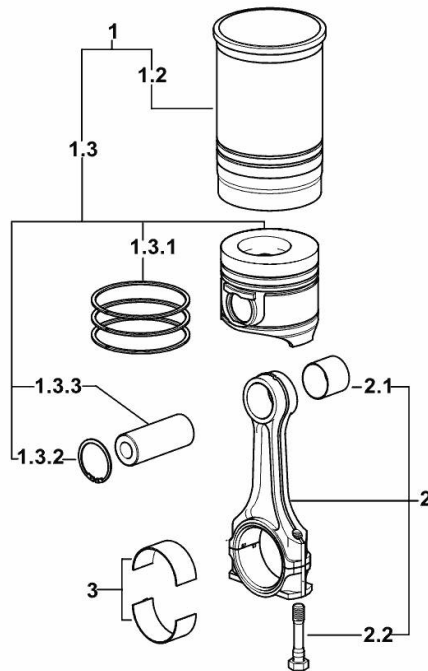

9\_M5212\_01\_M-A-001

Section: B0 - ENGINE

**TIMING CASE**

Fig.	P/n	QTY	Name
------	-----	-----	------

**Notes:**

[XS-90 (20") -> 3001]

4	2.0432.009.7	1	stud bolt m 8 p.1.25 / p. 1 x 35
15	2.0432.003.7	1	stud bolt m 8 p.1.25 / p.1 x 20
16	2.0312.214.2	7	screw m 8 p.1.25 x 40
17	2.1480.014.1	15	washer 8
18	0.013.4981.0	1	guard
19	0.065.1150.0/30	1	gasket
20	2.1470.004.2	4	lock washer 8
21	2.1011.405.2	2	nut m 8 p.1
22	2.0312.208.2	8	screw m 8 p.1.25 x 25
23	2.1529.167.0	1	oil seal

9\_M8211\_00\_0-B-001

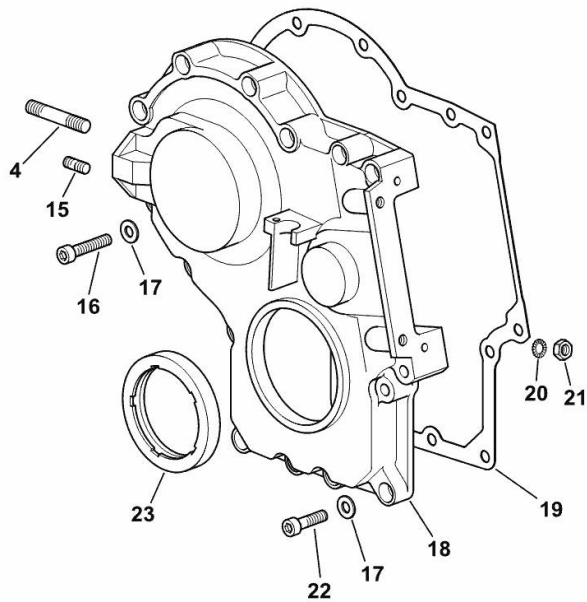

Section: B0 - ENGINE

**TIMING CASE**

Fig.	P/n	QTY	Name
------	-----	-----	------

**Notes:**

- EXPORT U.S.A. [XS-90 (20") -> 3001]

4	2.0432.009.7	1	stud bolt m 8 p.1.25 / p. 1 x 35
15	2.0432.003.7	1	stud bolt m 8 p.1.25 / p.1 x 20
16	2.0312.214.2	7	screw m 8 p.1.25 x 40
17	2.1480.014.1	15	washer 8
18	0.013.4981.0	1	guard
19	0.065.1150.0/30	1	gasket
20	2.1470.004.2	4	lock washer 8
21	2.1011.405.2	2	nut m 8 p.1
22	2.0312.208.2	8	screw m 8 p.1.25 x 25
23	2.1529.167.0	1	oil seal

9\_O1011\_00\_0-B-001

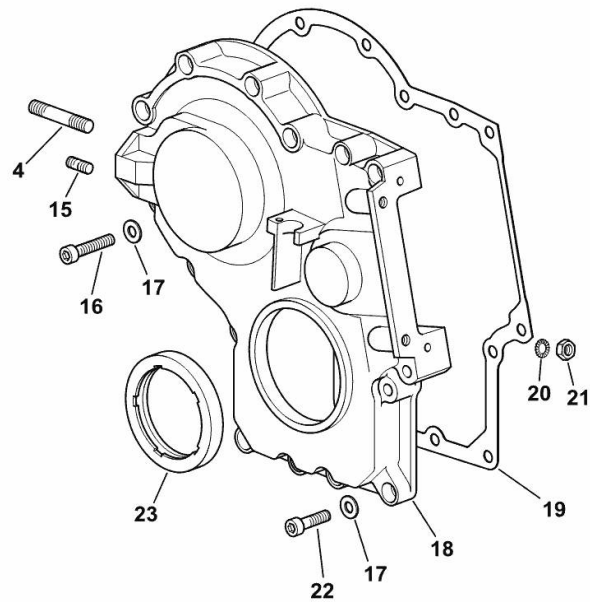

**GUARD PLATE**

Fig.	P/n	QTY	Name
------	-----	-----	------

**Notes:**

[XS-90 (20") -> 3001]

1	0.007.1262.3/50	1	guard
2	0.007.1271.0/10	1	small column m 8 p.1.25 / L = mm 60
3	0.007.1272.0/10	2	small column m 8 p.1.25 / L = mm 50
5	2.1310.004.2	3	flat washer 8.4x17
7	2.0112.203.2	3	screw m 8 p.1.25 x 12

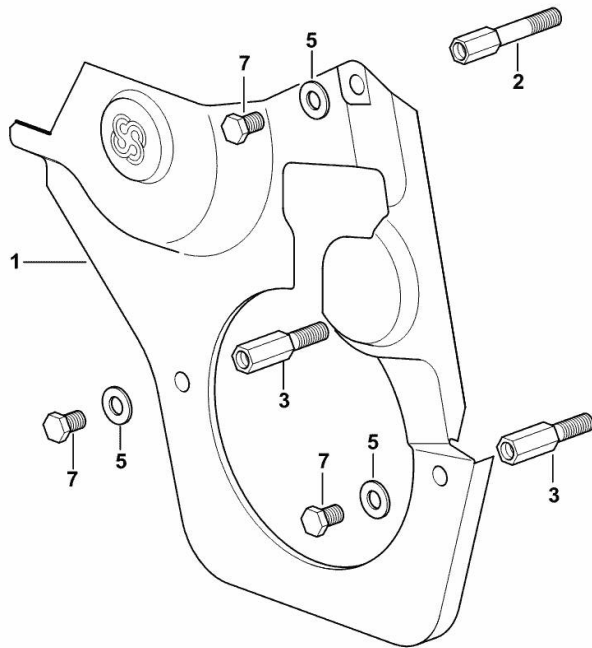

9\_33011\_02\_0-A-001

Section: B0 - ENGINE

**CASING COVER**

Fig.	P/n	QTY	Name
------	-----	-----	------

**Notes:**

[XS-90 (20") -> 3001]

30	0.065.1152.0	1	gasket
31	0.013.6374.2	1	cover
32	0.013.6368.0/20	4	stud bolt m 8 p.1 / = mm 51.5
34	2.1310.004.2	8	flat washer 8.4x17
35	2.1011.405.2	4	nut m 8 p.1

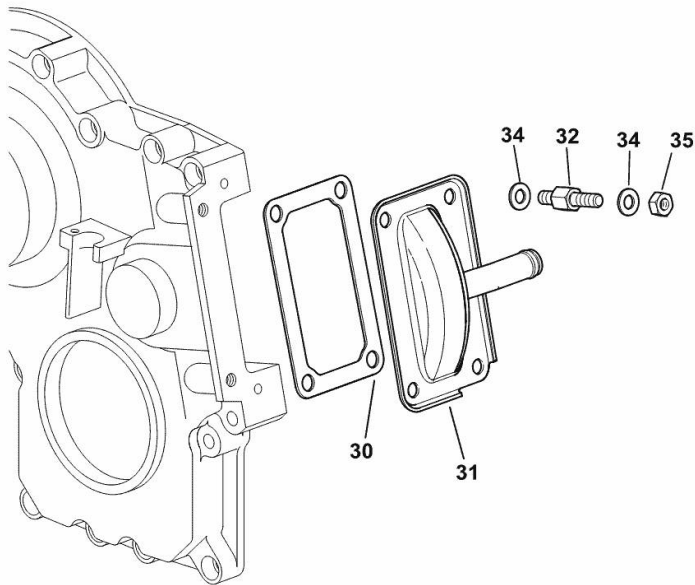

9\_N1411\_01\_0-A-001



Section: B0 - ENGINE

**CAMSHAFT**

Fig.	P/n	QTY	Name
------	-----	-----	------

**Notes:**

[XS-90 (20") -> 3001]

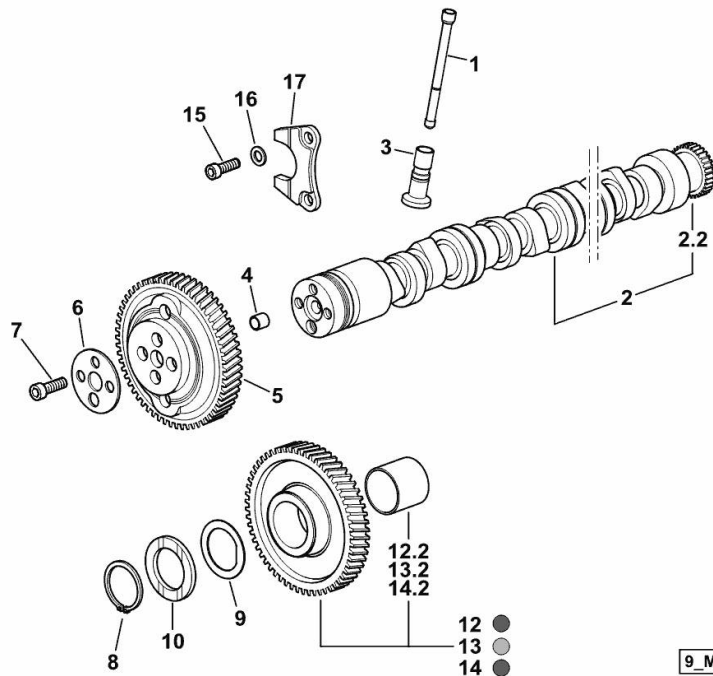

9\_M5213\_00\_0-A-001

1	0.065.1331.2	8	rod
2	0.012.6558.3/10	1	camshaft
2.2	0.065.1324.0/10	1	gear Z = 32
3	0.065.1330.0	8	tappets
4	2.1559.398.0	1	bushing 10.5x13x12
5	0.013.5017.0	1	gear z=58
6	0.065.1350.0	1	small disc
7	2.0132.207.2	4	screw m 10 p.1 x 25
8	2.1410.016.1	1	circlip 40
9	0.065.1352.0	1	shim
10	0.018.2233.0	2	shoulder ring
12	0.007.1177.3/20	0.4	gear z = 57 - WITH RED IDENTIFICATION STAMP
12.2	2.1559.185.0/10	1	bushing
13	0.007.1178.3/20	0.4	gear z = 57 - WITH YELLOW IDENTIFICATION STAMP
13.2	2.1559.185.0/10	1	bushing
14	0.007.1179.3/20	0.2	gear z = 57 - WITH GREEN IDENTIFICATION STAMP
14.2	2.1559.185.0/10	1	bushing
15	2.0312.205.2	2	screw
16	2.1480.014.1	2	washer 8
17	0.065.1353.0	1	small plate

Thank you so much for reading.  
Please click the “Buy Now!”  
button below to download the  
complete manual.



After you pay.

You can download the most  
perfect and complete manual in  
the world immediately.

Our support email:

[ebooklibonline@outlook.com](mailto:ebooklibonline@outlook.com)