

Section: B0 - ENGINE

**ENGINE TYPE-APPROVAL DATA PLATE**

Fig.	P/n	QTY	Name
------	-----	-----	------

**Notes:**

[XS110 -> ZKDU9602W0TH15001]

1	0.000.0000.1		cannot be supplied MADE BY TREVIGLIO ITALY
2	0.000.0000.1		cannot be supplied MADE AT RANIPET - INDIA

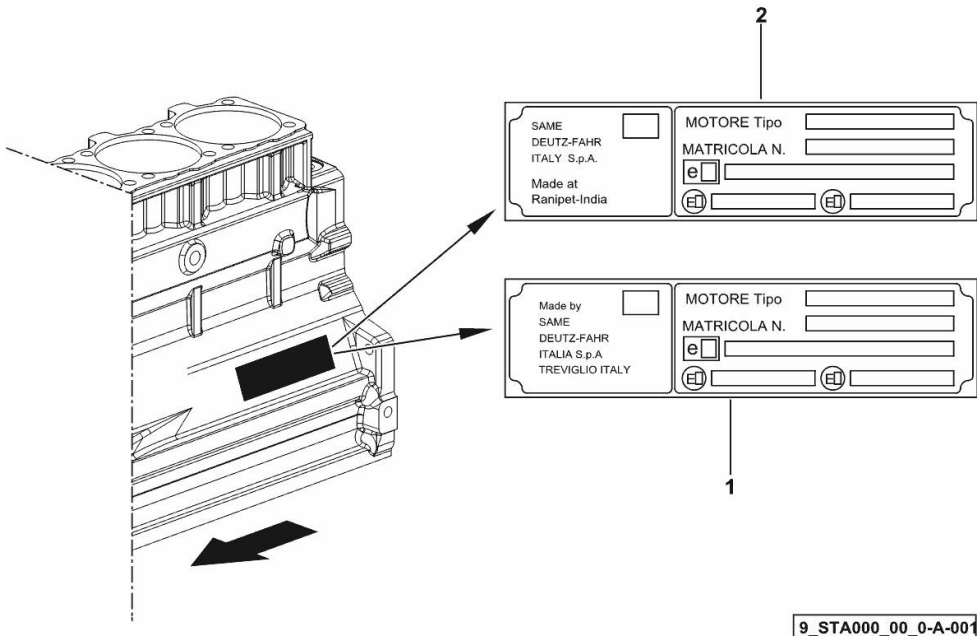

9\_STA000\_00\_0-A-001

Section: B0 - ENGINE

**CRANKCASE**

Fig.	P/n	QTY	Name
------	-----	-----	------

**Notes:**

FOR ENGINES PRODUCED IN : TREVIGLIO ITALY [XS110 -> ZKDU9602W0TH15001]



9\_O1011\_00\_0-A-001

3	2.3199.312.2/20	1	plug m 35x1.5x9.5
5	2.0439.279.7	8	stud bolt m 8 p.1 x 25
6	2.1559.188.2	4	bush 11.4 x 14 x16
7	2.1539.259.0	8	special oil seal 107.62x2.62
8	2.1560.010.0	1	gasket 14.2 x 20
9	2.3199.292.0	1	plug 1/4" gas
10	0.014.9655.4/30	1	crankcase
10.1	2.3130.001.1	14	plug 1/8" gas
10.2	2.3130.002.1	4	plug 1/4" gas
10.3	2.3130.003.1	6	plug 3/8" gas
10.4.1.1.1	0.065.1112.7/10	1	support
10.4.1.2	2.1699.165.0	1	bush 12.3x15x16
10.4.2	0.065.1114.0/10	3	support
10.4.3	0.065.1116.3	1	support
10.4.3.2	2.1699.165.0	1	bush 12.3x15x16
10.4.8	0.065.1117.0	10	screw m 12 x 100
10.5	2.3179.012.0	1	plug 60
10.6	0.065.1140.0	4	special bushing 59X55X20
10.7	0.065.1141.0	1	special bushing 59X55X30
10.8	0.014.1340.0/10	1	pin mm 85
11	0.066.1152.0/10	4	gasket
13	2.1549.154.2	4	bush 4.8x5.8x16
25	0.013.4946.0/10	1	sprayer nozzle
26	2.3120.101.0	1	plug m 18 p.1.5
28	2.1560.014.0	1	washer 18.2 x 24

**CRANKCASE**

Fig.	P/n	QTY	Name
------	-----	-----	------

**Notes:**

FOR ENGINES PRODUCED IN : RANIPET - INDIA [XS110 -> ZKDU9602W0TH15001]

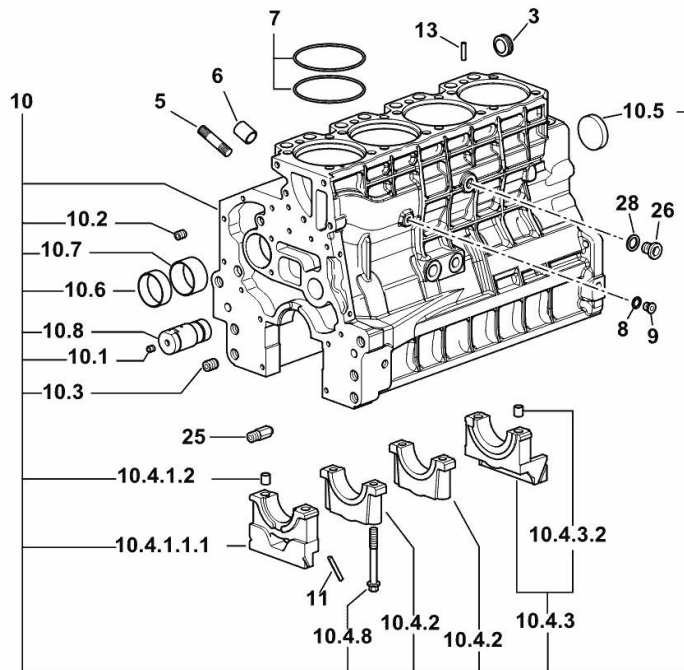

19\_O1011\_00\_0-A-001

3	2.3199.312.2/20	1	plug m 35x1.5x9.5
5	2.0439.279.7	8	stud bolt m 8 p.1 x 25
6	2.1559.188.2	4	bush 11.4 x 14 x16
7	2.1539.259.0	8	special oil seal 107.62x2.62
8	2.1560.010.0	1	gasket 14.2 x 20
9	2.3199.292.0	1	plug 1/4" gas
10	0.014.9655.4/30	1	crankcase
10.1	2.3130.001.1	14	plug 1/8" gas
10.2	2.3130.002.1	4	plug 1/4" gas
10.3	2.3130.003.1	6	plug 3/8" gas
10.4.1.1.1	0.065.1112.7/10	1	support
10.4.1.2	2.1699.165.0	1	bush 12.3x15x16
10.4.2	0.065.1114.0/10	3	support
10.4.3	0.065.1116.3	1	support
10.4.3.2	2.1699.165.0	1	bush 12.3x15x16
10.4.8	0.065.1117.0	10	screw m 12 x 100
10.5	2.3179.012.0	1	plug 60
10.6	0.065.1140.0	4	special bushing 59X55X20
10.7	0.065.1141.0	1	special bushing 59X55X30
10.8	0.014.1340.0/10	1	pin mm 85
11	0.066.1152.0/10	4	gasket
13	2.1549.154.2	4	bush 4.8x5.8x16
25	0.013.4946.0/10	1	sprayer nozzle
26	2.3120.101.0	1	plug m 18 p.1.5
28	2.1560.014.0	1	washer 18.2 x 24

**MONOBLOC ENGINE-GEARBOX CONNECTING FLANGE**

Fig.	P/n	QTY	Name
------	-----	-----	------

**Notes:**

FOR ENGINES PRODUCED IN : TREVIGLIO ITALY [XS110 -> ZKDU9602W0TH15001]

1	0.007.1882.0/50	1	flange
2	2.0112.511.2	8	screw m 14 p.2 x 30
3	2.1651.912.0	2	cylindrical plug 12x28
4	2.1651.917.0	1	cylindrical plug 12x40
5	2.0432.257.7	1	stud bolt m 12 p.1.75 - 1.25 x 30
6	2.0439.250.7	1	stud bolt m 12 / m 10 x 30
7	0.011.9294.0/10	1	bush

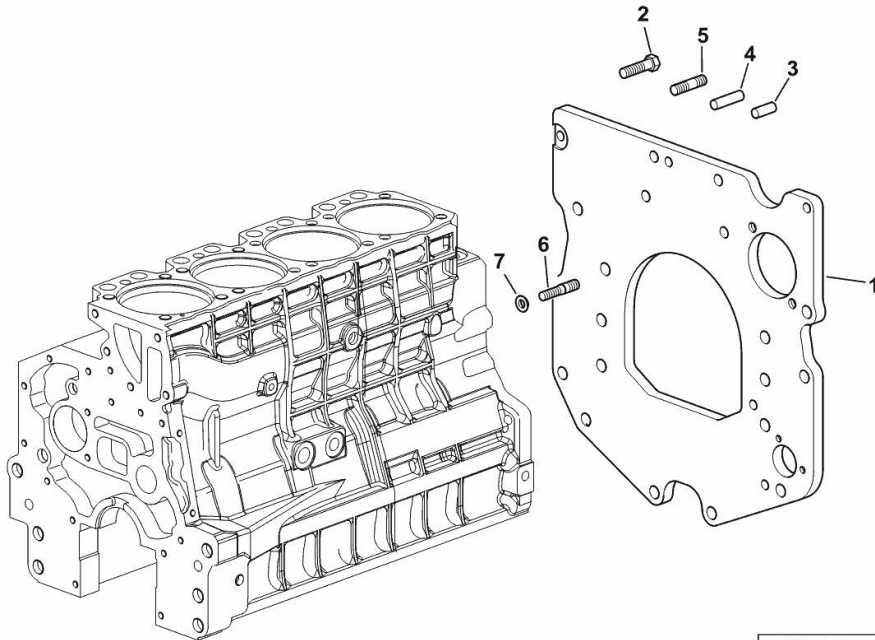

9\_38611\_01\_0-A-001

**MONOBLOC ENGINE-GEARBOX CONNECTING FLANGE**

Fig.	P/n	QTY	Name
------	-----	-----	------

**Notes:**

FOR ENGINES PRODUCED IN : RANIPET - INDIA [XS110 -> ZKDU9602W0TH15001]

1	0.007.1882.0/50	1	flange
2	2.0112.511.2	8	screw m 14 p.2 x 30
3	2.1651.912.0	2	cylindrical plug 12x28
4	2.1651.917.0	1	cylindrical plug 12x40
5	2.0432.257.7	1	stud bolt m 12 p.1.75 - 1.25 x 30
6	2.0439.250.7	1	stud bolt m 12 / m 10 x 30
7	0.011.9294.0/10	1	bush

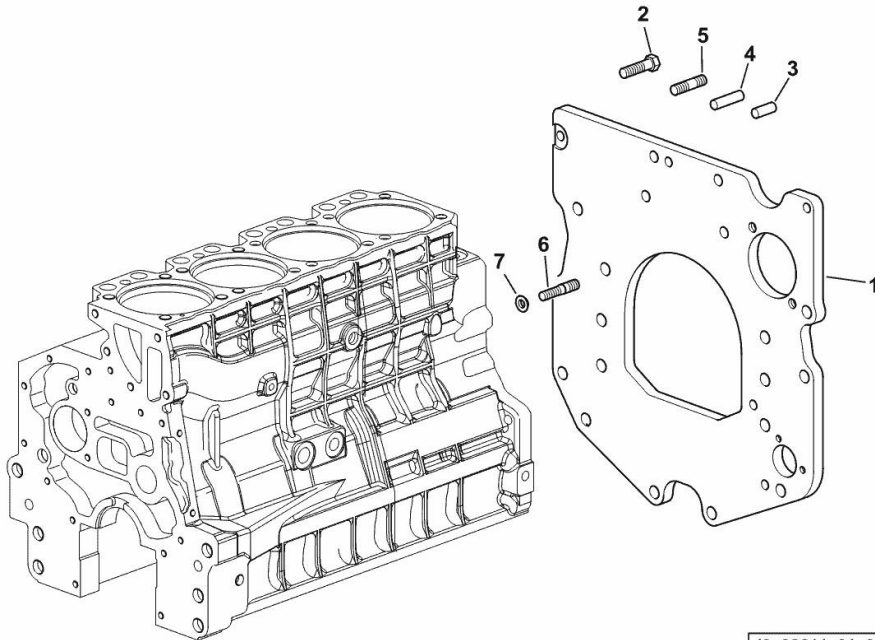

I9\_38611\_01\_0-A-001

**ENGINE OIL AND TURBO PRESSURE SWITCH UNION**

Fig.	P/n	QTY	Name
------	-----	-----	------

**Notes:**

FOR ENGINES PRODUCED IN : TREVIGLIO ITALY [XS110 -> ZKDU9602W0TH15001]

10	2.3339.787.0/10	1	pipe fitting 7/16"
11	2.3110.403.1	1	plug m 14 p.1.5x12
13	2.1019.129.2/10	1	nut m 18 p.1.5x12
14	2.1533.038.0	1	oil seal 15.45x2.62
15	2.1560.010.0	2	gasket 14.2 x 20

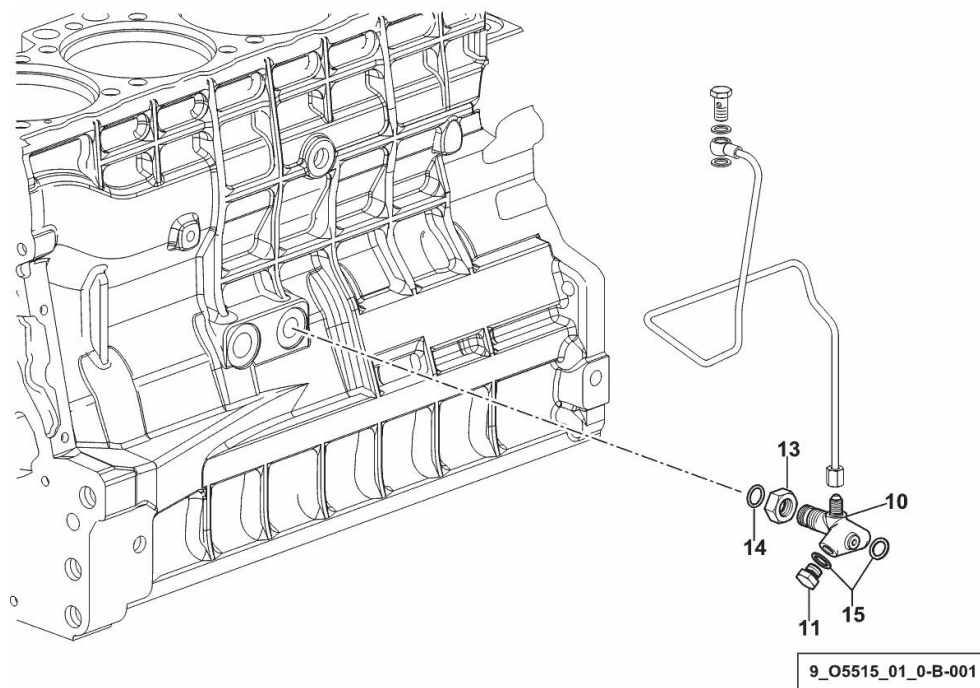

**ENGINE OIL AND TURBO PRESSURE SWITCH UNION**

Fig.	P/n	QTY	Name
------	-----	-----	------

**Notes:**

FOR ENGINES PRODUCED IN : RANIPET - INDIA [XS110 -> ZKDU9602W0TH15001]

10	2.3339.787.0/10	1	pipe fitting 7/16"
11	2.3110.403.1	1	plug m 14 p.1.5x12
13	2.1019.129.2/10	1	nut m 18 p.1.5x12
14	2.1533.038.0	1	oil seal 15.45x2.62
15	2.1560.010.0	2	gasket 14.2 x 20

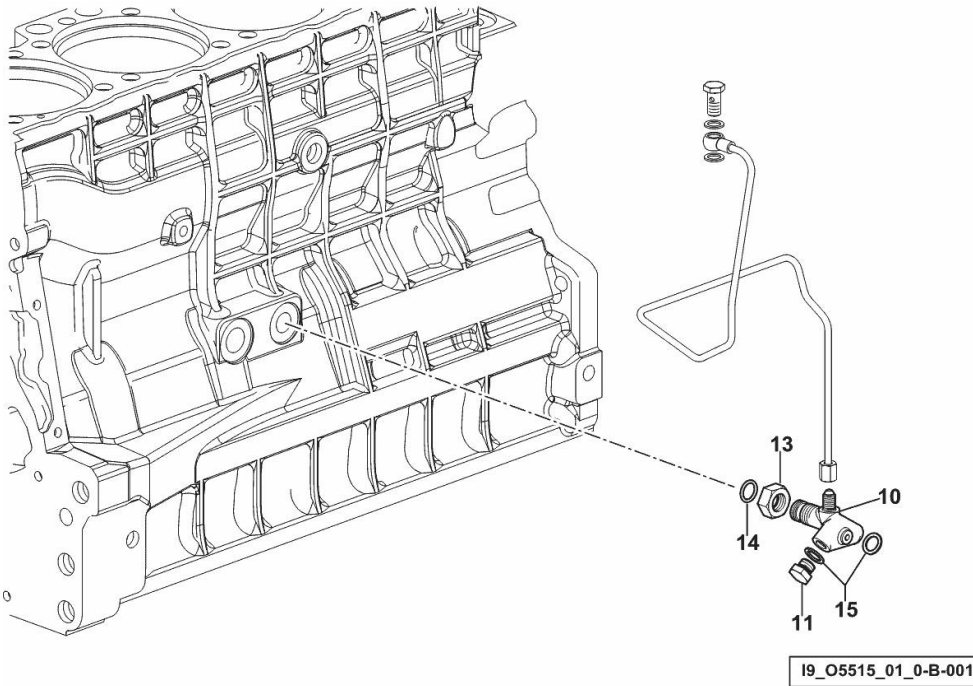

**SIDE PLUG FOR CYLINDER BLOCK**

Fig.	P/n	QTY	Name
------	-----	-----	------

**Notes:**

FOR ENGINES PRODUCED IN : TREVIGLIO ITALY [XS110 -&gt; ZKDU9602W0TH15001]

22	2.1560.017.0	1	gasket 22.2 x 27
23	2.3120.002.4	1	plug m 22 x 1.5

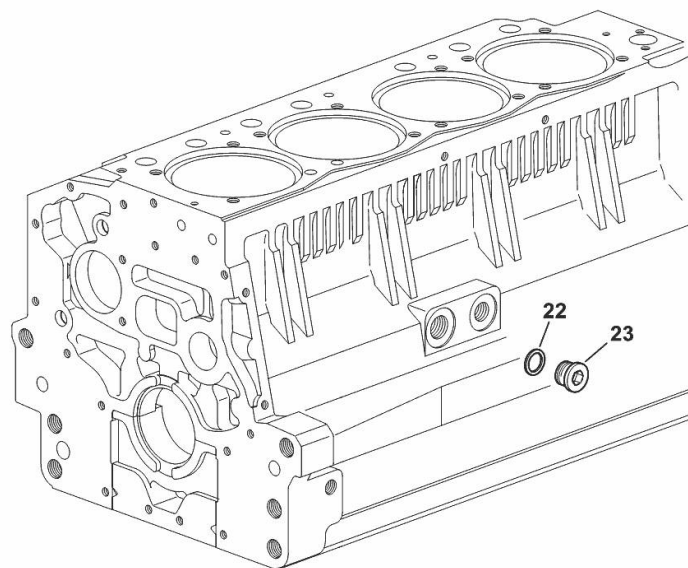

9\_33211\_07\_0-A-001



**SIDE PLUG FOR CYLINDER BLOCK**

Fig.	P/n	QTY	Name
------	-----	-----	------

**Notes:**

FOR ENGINES PRODUCED IN : RANIPET - INDIA [XS110 -> ZKDU9602W0TH15001]

22	2.1560.017.0	1	gasket 22.2 x 27
23	2.3120.002.4	1	plug m 22 x 1.5

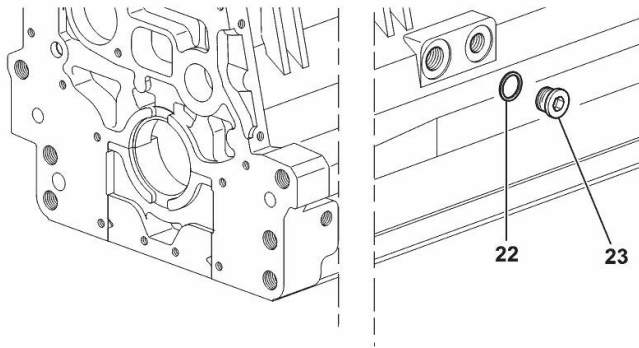

I9\_33211\_07\_0-A-001

**LOWER PLUG FOR CYLINDER BLOCKS**

Fig.	P/n	QTY	Name
------	-----	-----	------

**Notes:**

FOR ENGINES PRODUCED IN : TREVIGLIO ITALY [XS110 -> ZKDU9602W0TH15001]

1	2.3130.003.1	2	plug 3/8" gas
---	--------------	---	---------------

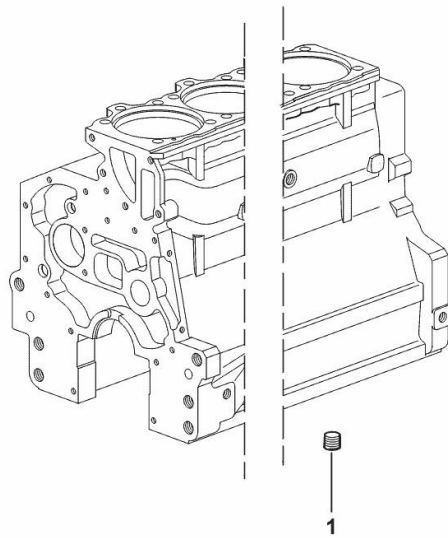

9\_33311\_06\_0-A-001

**LOWER PLUG FOR CYLINDER BLOCKS**

Fig.	P/n	QTY	Name
------	-----	-----	------

**Notes:**

FOR ENGINES PRODUCED IN : RANIPET - INDIA [XS110 -> ZKDU9602W0TH15001]

1	2.3130.003.1	2	plug 3/8" gas
---	--------------	---	---------------

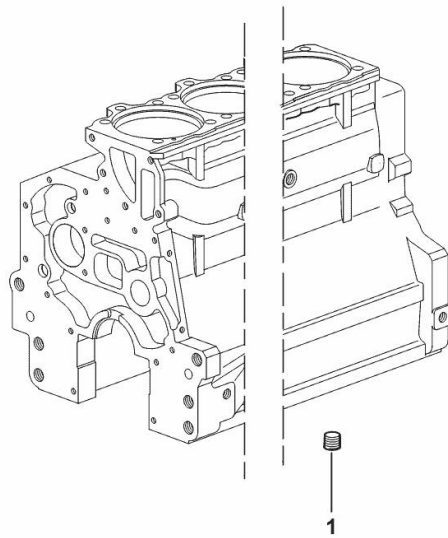

19\_37511\_06\_0-A-001

**ENGINE CRANKSHAFT PULLEY WITH RING-FEEDER RINGS**

Fig.	P/n	QTY	Name
------	-----	-----	------

**Notes:**

FOR ENGINES PRODUCED IN : TREVIGLIO ITALY [XS110 -> ZKDU9602W0TH15001]

1	0.015.6055.0	1	pulley
2	0.011.3515.0/20	1	hub Z = 48
3	0.065.1256.0	2	ring 45x52
4	2.1579.865.0	1	spacer 45.2x51.8x10
5	2.0439.195.7	1	stud bolt m 20 p.1.5x80
6	2.1019.094.7	1	nut m 20 p.1.5
7	2.0112.320.2	6	screw m 10 p.1.5 x 55
8	2.1470.006.2	6	lock washer 10

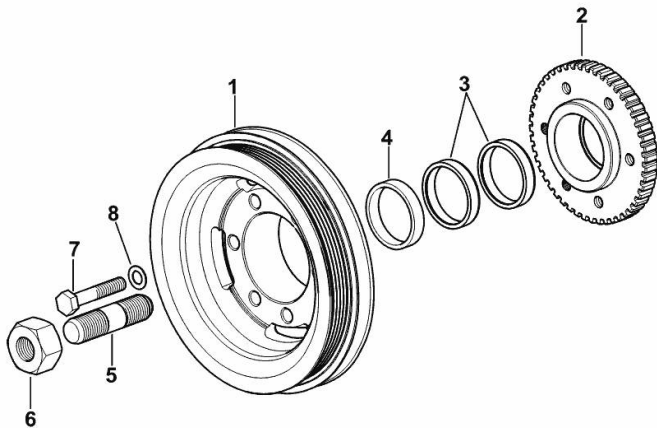

9\_O6312\_03\_0-A-001

**ENGINE CRANKSHAFT PULLEY WITH RING-FEEDER RINGS**

Fig.	P/n	QTY	Name
------	-----	-----	------

**Notes:**

FOR ENGINES PRODUCED IN : RANIPET - INDIA [XS110 -> ZKDU9602W0TH15001]

1	0.015.6055.0	1	pulley
2	0.011.3515.0/20	1	hub Z = 48
3	0.065.1256.0	2	ring 45x52
4	2.1579.865.0	1	spacer 45.2x51.8x10
5	2.0439.195.7	1	stud bolt m 20 p.1.5x80
6	2.1019.094.7	1	nut m 20 p.1.5
7	2.0112.320.2	6	screw m 10 p.1.5 x 55
8	2.1470.006.2	6	lock washer 10

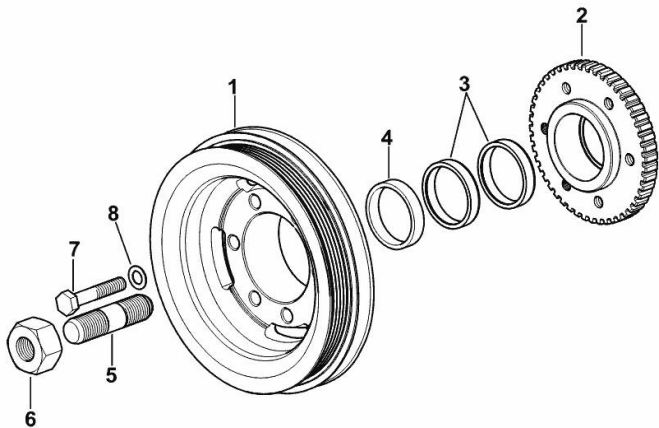

I9\_O6312\_03\_0-A-001

**COOLANT PUMP AND ALTERNATOR DRIVEBELT**

Fig.	P/n	QTY	Name
------	-----	-----	------

**Notes:**

[XS110 -> ZKDU9602W0TH15001]

1	2.4119.187.0	1	belt PV-K5 (mm 1230)
---	--------------	---	----------------------

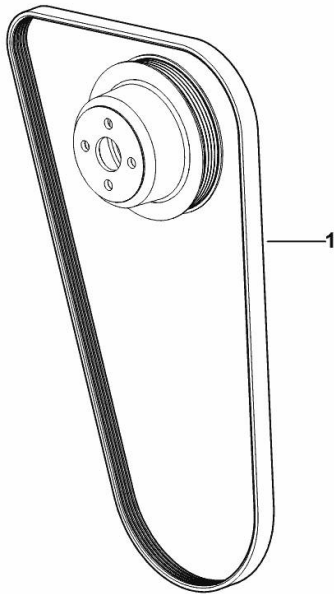

9\_O6817\_09\_0-A-001

Thank you so much for reading.  
Please click the “Buy Now!”  
button below to download the  
complete manual.



After you pay.

You can download the most  
perfect and complete manual in  
the world immediately.

Our support email:

[ebooklibonline@outlook.com](mailto:ebooklibonline@outlook.com)