

FRONT SUPPORT

Fig.	P/n	QTY	Name
------	-----	-----	------

Notes:
[XT 110 V-DRIVE]

1	0.014.7954.0/30	1	support
2	2.0119.232.2	2	screw m 16 p.2x98
3	2.1475.206.7	10	washer 17x32
4	2.0443.423.7	2	stud bolt m 16 p.1.5x90
5	2.0443.428.7	4	stud bolt m 16 p.1.5 x 130
6	2.1012.309.7	6	nut m 16 p.1.5
7	0.010.6375.0	2	shim mm 0.1
8	0.010.6376.0	6	shim mm 0.20
9	2.2680.047.0	2	ring 17x22x23
11	0.014.9314.2	1	gasket
12	2.0112.213.2	2	screw m 8 p.1.25 x 35
13	2.1470.004.2	2	lock washer 8
14	2.3199.360.0	12	plug m 14 p.2
15	2.3199.361.0	8	plug m 18 p.2.5

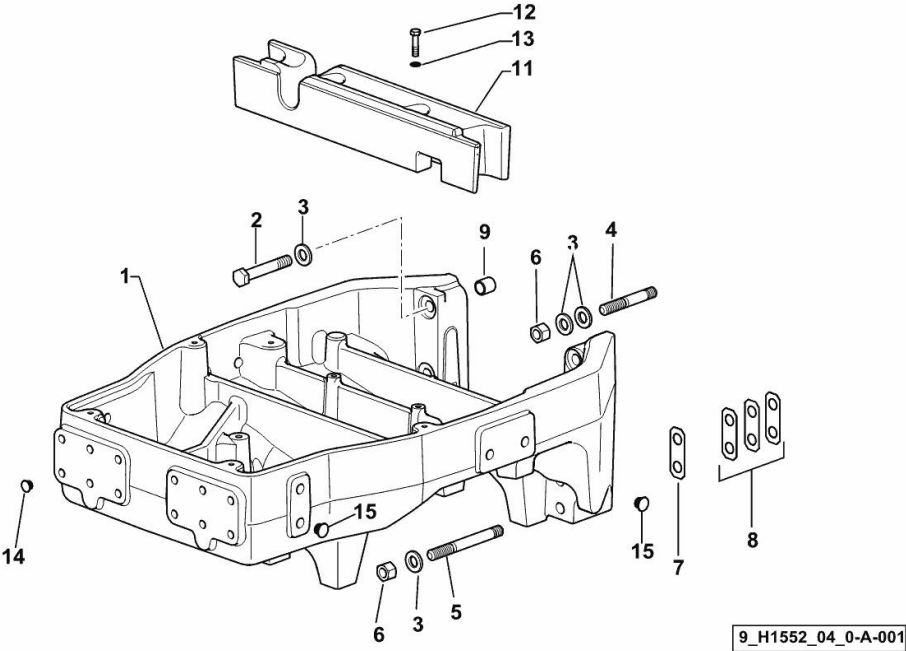

4WD - FRONT SUPPORT WITH FRONT PTO

Fig.	P/n	QTY	Name
------	-----	-----	------

Notes:
[XT 110 V-DRIVE]

1	0.014.7955.0/50	1	support
2	2.0119.232.2	2	screw m 16 p.2x98
3	2.1475.206.7	8	washer 17x32
4	2.0443.423.7	2	stud bolt m 16 p.1.5x90
5	2.0443.428.7	4	stud bolt m 16 p.1.5 x 130
6	2.1012.309.7	6	nut m 16 p.1.5
7	0.010.6375.0	2	shim mm 0.1
8	0.010.6376.0	6	shim mm 0.20
9	2.2680.047.0	2	ring 17x22x23
10	2.1579.820.2	4	spacer 13x25x30
11	0.014.9315.2/10	1	gasket
12	2.0112.213.2	2	screw m 8 p.1.25 x 35
13	2.1470.004.2	2	lock washer 8
14	2.3199.360.0	12	plug m 14 p.2
15	2.3199.361.0	8	plug m 18 p.2.5

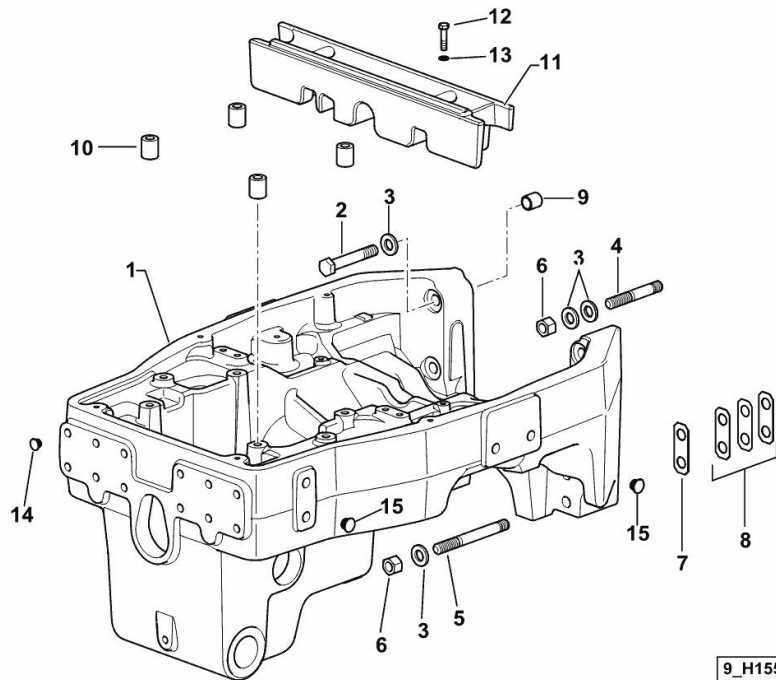

9_H1552_02_0-A-001

Section: F0 - FRONT AXLE
4WD - FRONT SUPPORT

Fig.	P/n	QTY	Name
------	-----	-----	------

Notes:
 [XT 110 V-DRIVE]

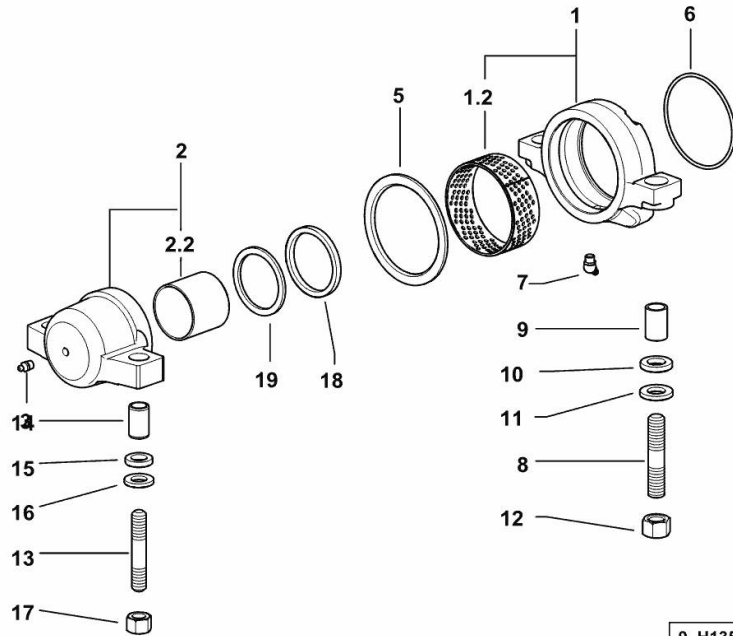

9_H1352_03_0-A-001

1	0.146.5233.3/40	1	support
1.2	2.1559.455.0	1	special bushing 100x106x40
2	0.010.4723.3/50	1	support
2.2	2.1559.456.0	1	special bushing
3	2.3820.105.2	1	grease gun m 10 p.1 x 7
5	2.1599.004.0	1	shoulder ring 101x125x4
6	2.1530.205.0	1	oil seal 101.2x5.34
7	2.3821.103.2	1	grease gun m 10 p.1x10
8	2.0439.174.7	2	stud bolt m 18 p.1.5x70
9	2.1559.010.0	2	special bushing 18.5x24x35
10	2.1599.030.2	2	shoulder ring 19x35x6
11	2.1475.107.2	2	washer 19.4x36
12	2.1019.060.2	2	special nut m 18 p.1.5
13	2.0433.419.7	2	stud bolt m 16 p.2-1.5x70
14	2.1559.030.0	2	special bushing 16.5x22x35
15	2.1599.029.2	2	washer 17x30x6
16	2.1475.206.2	2	spring washer 16
17	2.1012.309.2	2	nut
18	2.1535.028.0	1	oil seal 67x11
19	2.1599.825.0	1	shoulder ring 63x77x4

PROVISION FOR FRONT PTO MOUNTING

Fig.	P/n	QTY	Name
------	-----	-----	------

Notes:
[XT 110 V-DRIVE]

1	0.011.0754.0	1	plug 60
2	0.010.4072.0	1	plug 40
3	0.011.0753.2/20	1	plug
4	2.1310.007.2	1	flat washer 13 x 24
5	2.0112.407.2	1	screw m 12 p.1.75 x 20
6	2.3171.019.4	2	plug 50
7	0.010.4129.0/20	1	plate
8	2.1310.009.2	2	flat washer 15x20
9	2.0112.509.2	2	screw m 14 p.1.5x25
10	0.011.2616.2/20	1	shield dx/rh/re
11	2.1310.006.2	2	flat washer 10.5x21
12	2.0112.305.2	2	screw m 10 p.1.5 x 16
13	2.1310.007.2	2	flat washer 13 x 24
14	2.0112.407.2	2	screw m 12 p.1.75 x 20
15	0.011.2615.2/20	1	shield sx/lh/li
16	0.015.1911.0/20	1	plate
17	2.1470.007.2	4	lock washer 12
18	2.0112.421.2	4	screw m 12 p.1.75 x 60

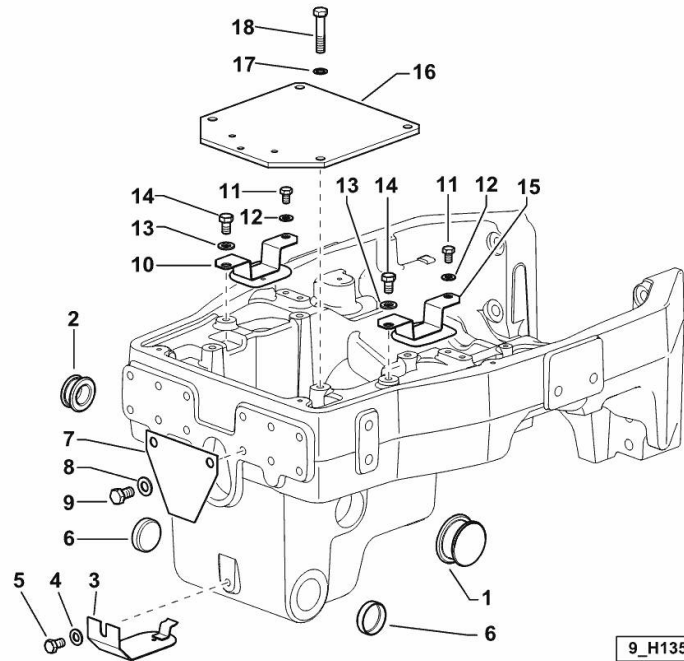

9_H1352_06_0-A-001

4WD - FRONT DRIVE AXLE

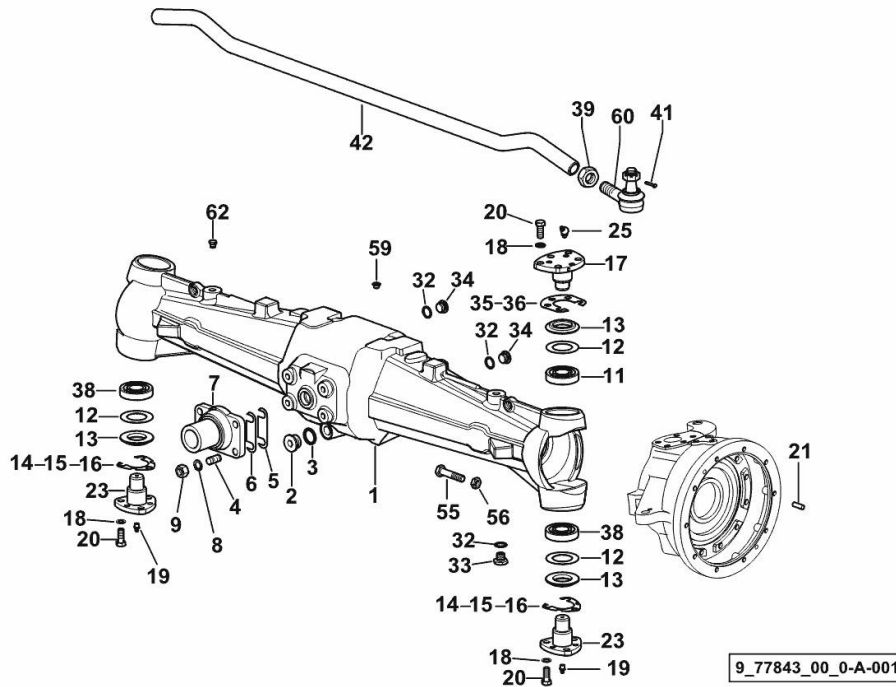

Fig.	P/n	QTY	Name
Notes:			
[XT 110 V-DRIVE]			
1	0.010.6083.0/60	1	front axle
2	2.3199.021.2	1	plug 1/2 gas
3	2.1560.054.0	1	gasket 21 x 26
4	2.0433.309.7	4	stud bolt m 14 p.1.5x35
5	2.1379.004.0/10	4	small plate 15x15x62x1.5
6	2.1379.003.0/10	4	small plate 15x15x62x0.12
7	0.010.4724.0/20	1	pin
8	2.1475.005.2	4	washer 14
9	2.1011.308.2	4	nut m 14 p.1.5
11	2.2530.007.0	1	roller bearing iso 30 kb 03
12	2.1599.260.0	4	shoulder ring 43x71x1
13	2.1519.045.0	4	special oil seal 41x73x9
14	0.463.4351.0	8	shim mm 0.50
15	0.463.4350.0	8	shim mm 0.20
16	0.463.4352.0	8	shim mm 0.15
17	0.255.4335.0/10	1	pin
18	2.1470.007.2	9	lock washer 12
19	2.3820.105.2	2	grease gun m 10 p.1 x 7
20	2.0112.411.2	9	screw m 12 p.1.75 x 30
21	2.1651.811.0	4	cylindrical plug 10x24
23	0.169.4337.0/10	2	pin
25	2.3821.102.2	1	grease gun m 8 p.1 x 8
32	2.1560.054.0	5	gasket 21 x 26
33	2.3199.021.2	2	plug 1/2 gas
34	2.3199.001.2	3	plug 1/2" gas
35	2.1589.124.0	8	shoulder ring mm 0.20
36	2.1589.126.0	8	shoulder ring mm 0.15
38	2.2550.007.0	2	roller bearing 30x72x28.75
39	2.1099.020.1	2	special nut m 24 p.1.5
41	2.1690.412.2	2	split pin 4 x 30
42	0.010.5537.0/10	1	rod
55	2.0119.213.2	4	screw m 14 p.2 x 60
56	2.1011.208.2	4	nut m 14 p.2
59	2.3199.386.0	5	plug Ø 11
60	0.010.0488.4/10	2	joint
62	2.3199.125.0	1	⚙ 0.010.0488.4/10 plug 1/8" gas

STEERING SENSOR SUPPORT SBA/ASM

Fig.	P/n	QTY	Name
------	-----	-----	------

Notes:
[XT 110 V-DRIVE]

3	0.010.4627.0/10	1	guard
5	0.011.2308.0/10	1	pin
6	2.2520.008.0	1	roller bearing 35x72x18,25
7	0.010.0008.2	1	joint
9	0.011.2252.0	1	cap-washer
11	2.1530.024.0	1	oil seal 10.78 x 2.62
20	0.010.4355.0/10	1	cover
99.1	2.0112.423.2	4	screw m 12 p.1.75 x 70
99.2	2.1470.007.2	5	lock washer 12
99.4	2.3821.102.2	1	grease gun m 8 p.1 x 8
99.12	2.1470.004.2	2	lock washer 8
99.13	2.0112.411.2	1	screw m 12 p.1.75 x 30
99.15	2.0112.009.2	1	screw m 6 p.1 x 25
99.16	2.1470.002.2	1	lock washer 6
99.17	2.6839.066.0/10	1	clamp 16
99.18	2.1549.341.2	1	spacer 6.5x11x11
99.19	2.1310.007.2	2	flat washer 13 x 24
99.21	2.0312.206.2	2	screw m 8 p 1.25 x 20

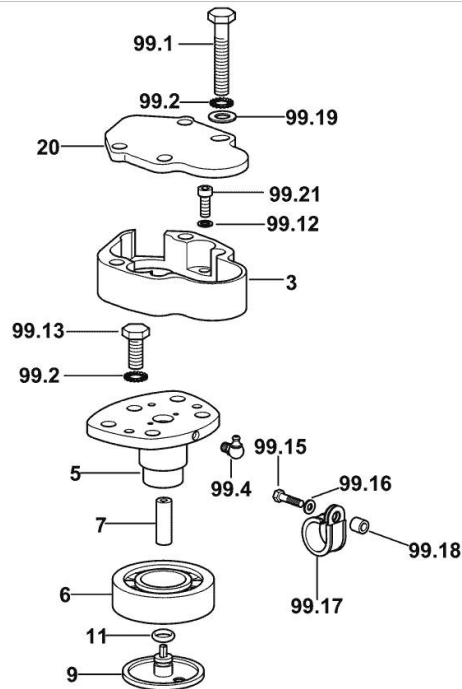

9_77843_01_0-A-001

4WD - FRONT AXLE FORKS FOR TYPES WITH BRAKES

Fig.	P/n	QTY	Name
------	-----	-----	------

Notes:
[XT 110 V-DRIVE]

10	0.016.3302.0/10	1	fork dx/rh/re
30	2.1529.134.0	2	special oil seal 65x90x17.5
37	0.016.3301.0/10	1	fork sx/lh/li
100.22	2.0433.155.7	20	stud bolt m 10 p.1.25 x 25
100.38	2.3199.125.0	2	plug 1/8" gas

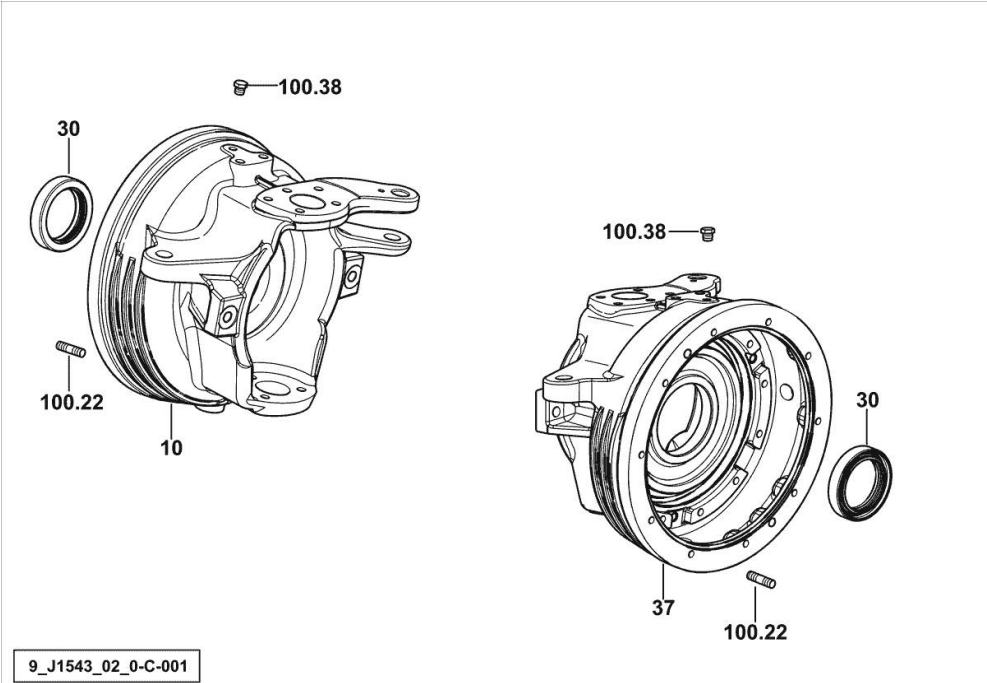

AIR BREATHER AND STEERING STOP - 4WD

Fig.	P/n	QTY	Name
------	-----	-----	------

Notes:
[XT 110 V-DRIVE]

30	0.135.4363.3/10	3	valve
31	0.270.4355.0	2	guard
32	2.0112.304.2	2	screw m 10 p.1.5x14
33	2.1310.006.2	2	flat washer 10.5x21
55	0.010.8798.0	2	spacer
63	2.0119.228.2	2	screw m 14 p.2 x 40
64	2.1011.208.2	2	nut m 14 p.2

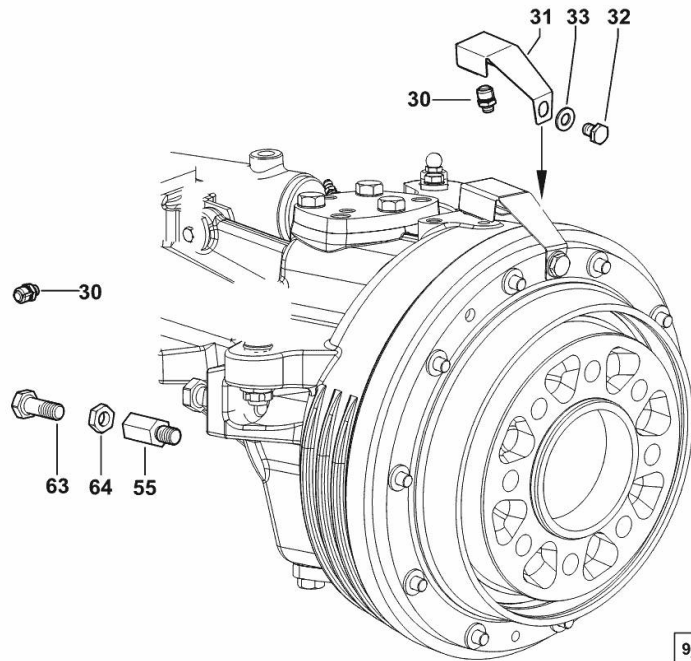

STEERING ROD - MECH. STEERING - TELESCOPIC AXLE

Fig.	P/n	QTY	Name
1	0.010.0488.4/10	1	joint
2	0.900.0025.7	1	guard
3	0.900.0025.8	1	nut

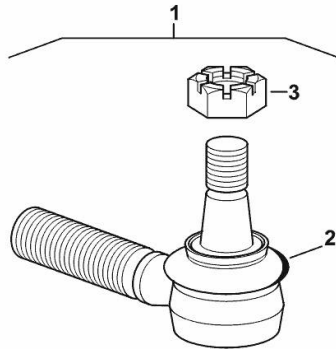

0_010_0488_4_10

4WD - FLANGE

Fig.	P/n	QTY	Name
------	-----	-----	------

Notes:
[XT 110 V-DRIVE]

1	0.015.0554.0	1	flange
2	2.1699.434.0	2	pin m 14 p.1.5 x 16
3	2.1475.004.2	13	spring washer 12
4	2.0113.415.2	9	screw m 12 p.1.75 x 40
5	2.0113.413.2	4	screw m 12 p.1.75x35

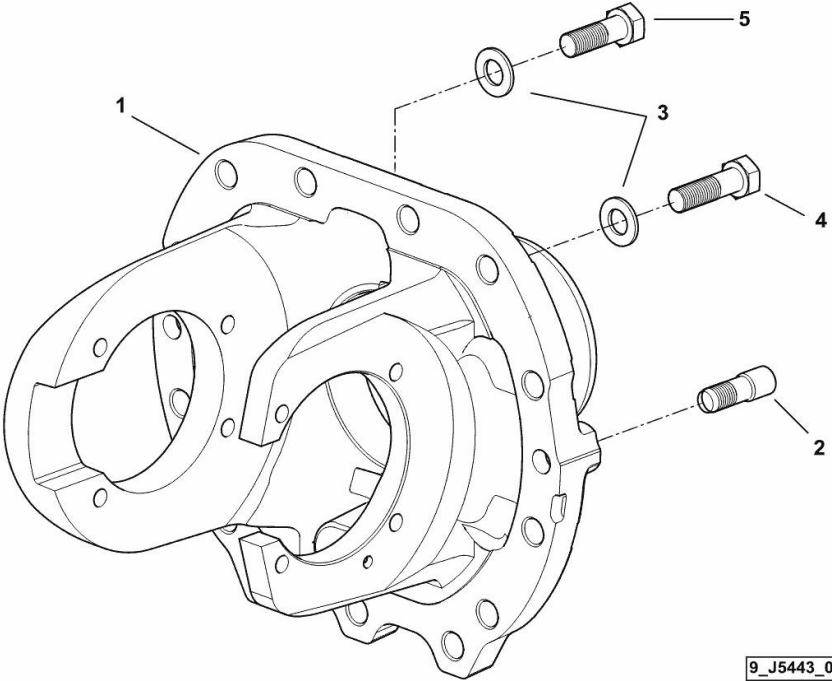

9_J5443_01_0-A-001

4WD - BEVEL WHEEL GEAR

Fig.	P/n	QTY	Name
------	-----	-----	------

Notes:
[XT 110 V-DRIVE]

1	0.015.0324.3/10	1	bevel drive z=19 z=43
---	-----------------	---	-----------------------

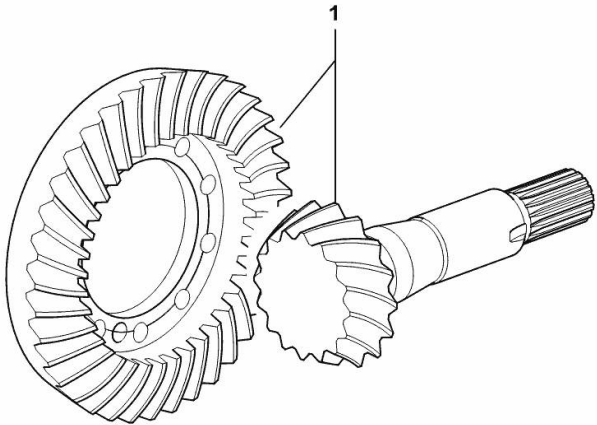

9_J5446_02_0-A-001

DIFFERENTIAL SEAL RINGS

Fig.	P/n	QTY	Name
------	-----	-----	------

Notes:

[XT 110 V-DRIVE]

2	2.1529.007.0/10	1	special oil seal 58 x 80 x 13
4	0.255.4650.0	1	spacer 35 x 58 x 19

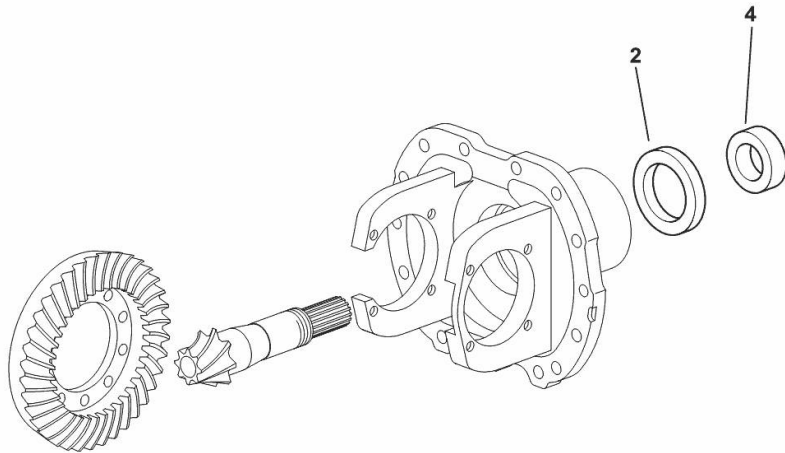

9_62346_01_0-A-001

4WD - STANDARD SEALING

Fig.	P/n	QTY	Name
------	-----	-----	------

Notes:

[XT 110 V-DRIVE]

1	2.1559.453.0	1	bushing 30x40x31
2	2.1520.120.0	1	oil seal 40x55x8
3	0.013.8711.0	1	special bushing

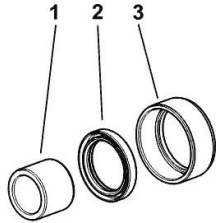

9_J5426_01_0-A-001

4WD - FRONT DIFFERENTIAL

Fig.	P/n	QTY	Name
------	-----	-----	------

Notes:
[XT 110 V-DRIVE]

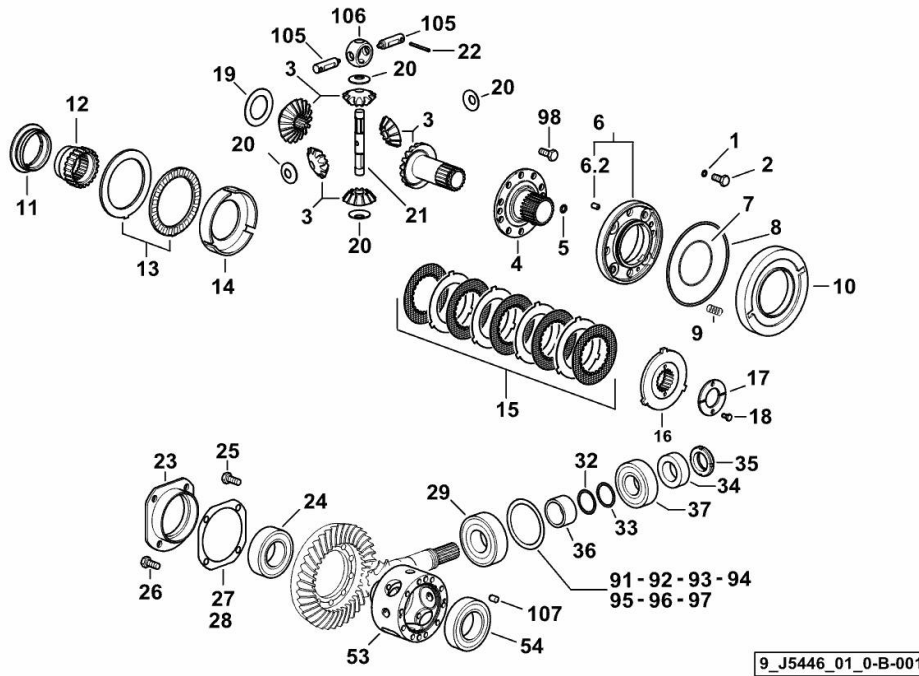

1	2.1532.014.0	4	oil seal 7.65 x 1.78
2	2.0119.199.2	4	screw 7/8"-9UCX88.9
3	0.013.6073.3/20	1	planet gear
4	0.009.7642.0/50	1	flange
5	2.1530.018.0	1	oil seal 9.19 x 2.62
6	0.015.6526.3	1	flange
6.2	2.1699.250.0/20	1	pin 8 x 12
7	2.1539.171.0	1	special oil seal 75.87 x 2.62
8	2.1532.246.0	1	oil seal 142.47x3.53
9	2.4019.614.1	4	spring
10	0.009.7630.0/40	1	piston
11	0.009.7635.0/40	1	ring nut m72x1.5x85x21
12	0.009.7632.0/30	1	hub
13	2.2999.335.0/10	1	special bearing 90x5
14	0.009.7637.0/10	1	box
15	0.010.4526.3	1	hydraulic PTO clutch kpl.
16	0.009.7631.0/10	1	hub
17	0.009.7634.0/10	2	slewing ring
18	2.0312.102.2	2	screw m 6 p.1 x 12
19	2.1599.431.0	1	shoulder ring 42x66x2
20	0.255.4629.0	4	shoulder ring 15.5x36x2
21	0.013.6067.0	1	pin
22	2.1631.418.0	2	pin 5 x 45
23	0.255.4652.0/20	1	flange
24	2.2540.005.0	1	roller bearing 45 x 85 x 24.75
25	2.0139.025.1	10	screw m 10 p.1.25 x 25
26	2.0132.207.2	4	screw m 10 p.1 x 25
27	0.146.4654.0/10	4	shim 96x127x0.5
28	0.146.4653.0/10	4	shim 96x127x0.2
29	2.2560.006.0	1	roller bearing 40 x 90 x 25.25
32	2.1580.101.0	2	shim 36 x 43 x 0.2
33	2.1580.102.0	3	shim 36 x 43 x 0.5
34	0.255.4650.0	1	spacer 35 x 58 x 19
35	2.1214.008.7	1	ring nut 35 md
36	0.010.1045.0	1	spacer mm 37
37	2.2560.005.0	1	roller bearing 35 x 80 x 22.75
53	0.013.6062.0/40	1	differential carrier
54	2.2999.315.0	1	special bearing
91	2.1589.356.0	1	shoulder ring 73x89.5x0.6
92	2.1589.357.0	0.3	shoulder ring 73x89.5x0.7
93	2.1589.358.0	0.3	shoulder ring 73x89.5x0.8

4WD - FRONT DIFFERENTIAL

Fig.	P/n	QTY	Name
94	2.1589.359.0	0.3	shoulder ring 73x89.5x0.9
95	2.1589.360.0	0.3	shoulder ring 73x89.5x1.65
96	2.1589.361.0	0.3	shoulder ring 73x89.5x1.75
97	2.1589.362.0	0.3	shoulder ring 73x89.5x1.85
98	2.0139.002.1	10	screw m 10 p.1.25 x 20
105	0.013.6068.0	2	pin
106	0.013.6070.0	1	ring
107	2.1659.523.0	4	pin 10 x 16

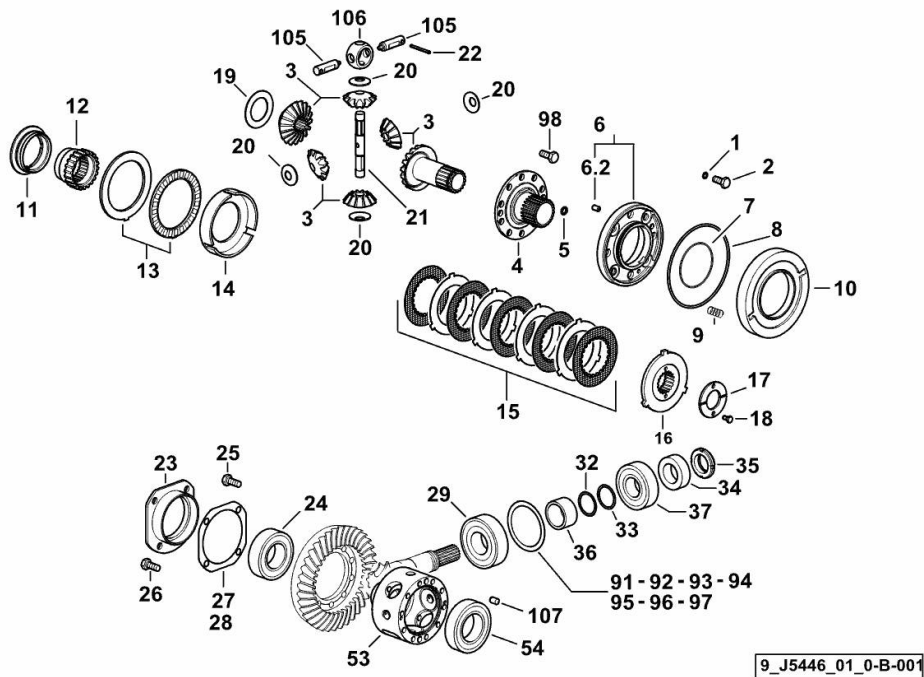

Thank you so much for reading.
Please click the “Buy Now!”
button below to download the
complete manual.



After you pay.

You can download the most
perfect and complete manual in
the world immediately.

Our support email:

ebooklibonline@outlook.com