

## Validity of the manual

This manual is valid for the machine/front attachment:

Designation	Type	Machine number	
		from	to
XERION TRAC 3800 -3300	781	78100011	–
XERION TRAC VC 3800 -3300	781	78100011	–
XERION SADDLE TRAC 3800 -3300	781	78100011	–

**XERION 3800-3300**

# **Repair Manual**

**Type 781**

**Original repair manual**

## Diesel engine

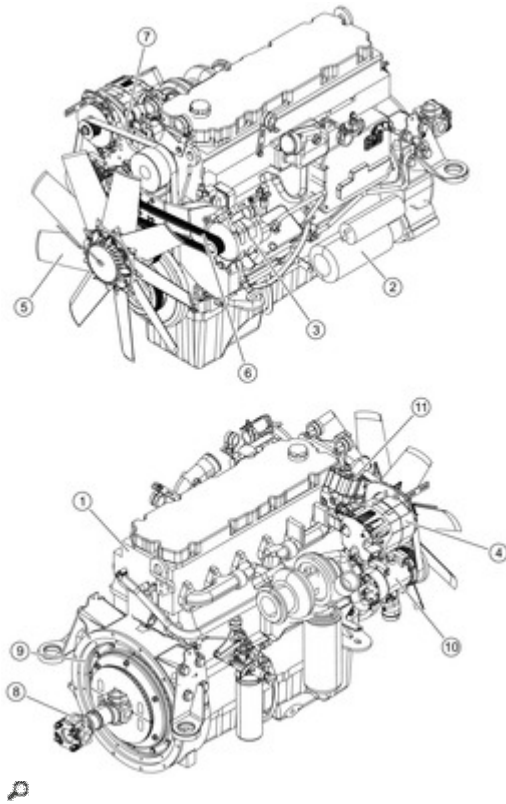

Item	Value	CCN	Remark / designation
1	1400 kg		Diesel engine C9
2			Electric starting motor (M21) <u>Electric starting motor (M21)</u>
3			Alternator (G2-1) <u>Alternator (G2-1 / G2-2)</u>
4			Alternator (G2-2) <u>Alternator (G2-1 / G2-2)</u>
5			Fan blade assembly <u>Fan blade assembly</u>
6			Belt (R1) <u>Fan drive belt (R1)</u>
7			Belt (R2) <u>Air conditioner compressor drive belt (R2)</u>
8			Main drive universal drive shaft (GW1) <u>Universal drive shaft main drive</u>

Item	Value	CCN	Remark / designation
9			Torsion damper <u>Torsion damper</u>
10			Air conditioner compressor <u>Air conditioner compressor</u>
11			Thermostat <u>Thermostat</u>
Tightening torques not specified, see section on tightening torques			

### **NOTICE**

Lubricants and fuels end up in the environment.

Environmental pollution

- ▶ Collect and store lubricants and fuels in suitable containers and dispose of them properly.

### **Removing**

- ▶ Remove cab.  
Cab
  - ▶ Only for SADDLE TRAC
- ▶ Remove steps.
- ▶ Remove the front wheels.
- ▶ Drain the diesel engine coolant. 
- ▶ Withdraw the air conditioner refrigerant.  
Air conditioning system – General information
- ▶ Remove the alternators.  
Alternator (G2-1 / G2-2)
- ▶ Remove electric starting motor.  
Electric starting motor (M21)
- ▶ Remove the fan blade assembly.  
Fan blade assembly
- ▶ Remove the fan hub.  
Fan hub

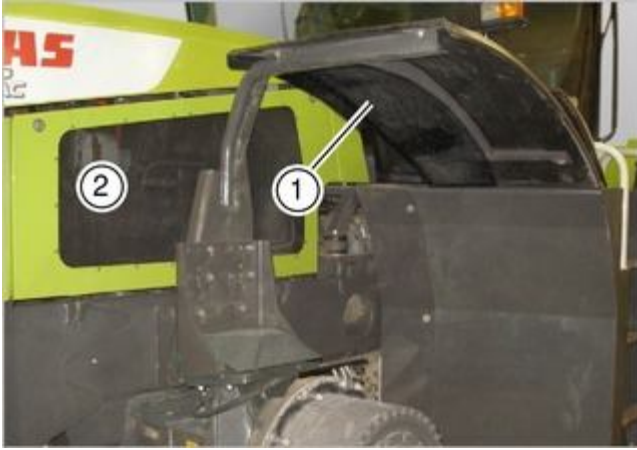

### On TRAC / TRAC VC

- ▶ Unscrew mud guard (1).
- ▶ Remove covering (2).
- ▶ Repeat this process on the other side of the machine.



### On TRAC / TRAC VC

- ▶ Unscrew sheet metal cover (1).
- ▶ Unscrew plate (2).

### On SADDLE TRAC

- ▶ Remove platform.  
Platform

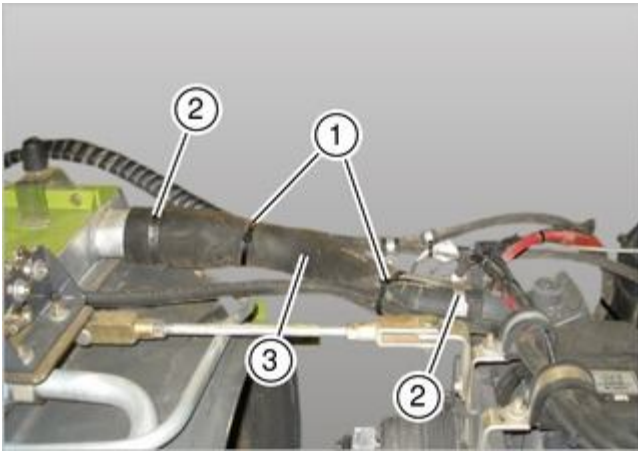

- ▶ Remove cable band (1).
- ▶ Unscrew clamps (2).
- ▶ Disconnect hose (3) and close both sides with a plug.



- ▶ Remove cable band (1).
- ▶ Unscrew clamps (2).
- ▶ Disconnect hose (3) and close both sides with a plug.

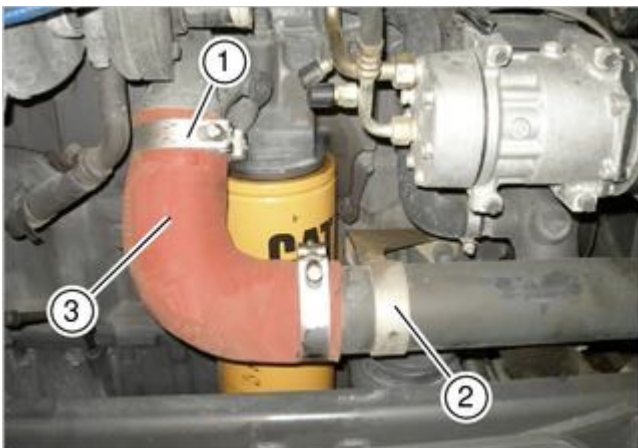

- ▶ Unscrew clamp (1).
- ▶ Unscrew clamp (2).
- ▶ Disconnect hose (3) and close both sides with a plug.

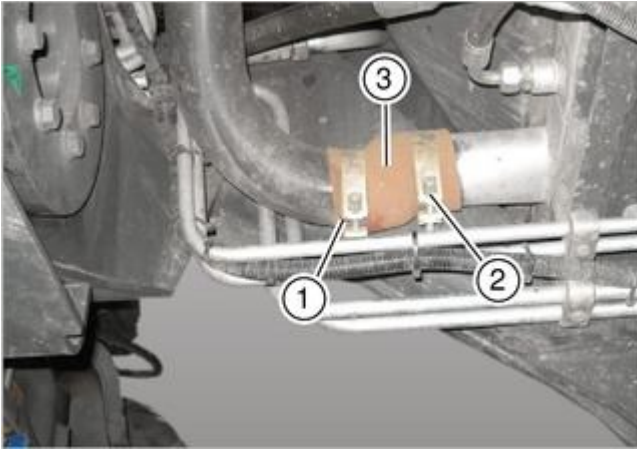

- ▶ Unscrew clamp (1).
- ▶ Unscrew clamp (2).
- ▶ Disconnect hose (3) and close both sides with a plug.

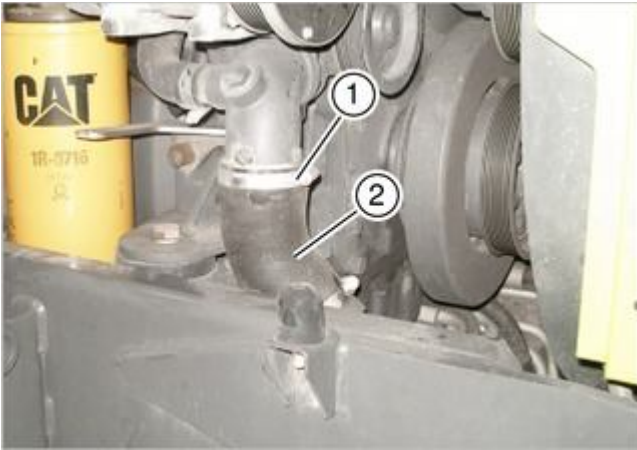

- ▶ Unscrew clamp (1).
- ▶ Disconnect hose (2), seal with plugs on both sides and tie it aside.

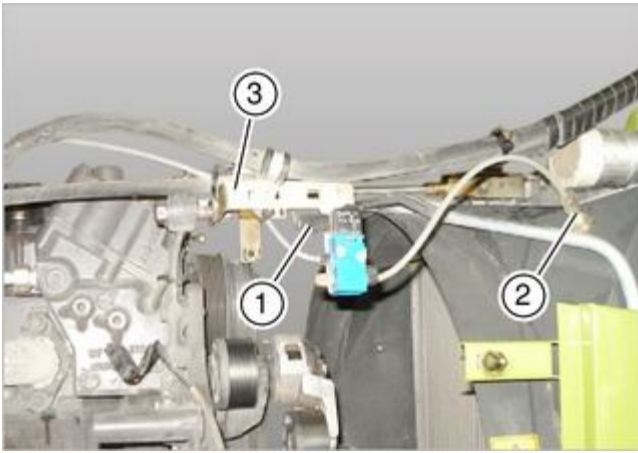

- ▶ Disconnect connectors (1).
- ▶ Unscrew hose (2) and close both sides with a plug.
- ▶ Unscrew bracket (3).



- ▶ Disconnect connectors (1).

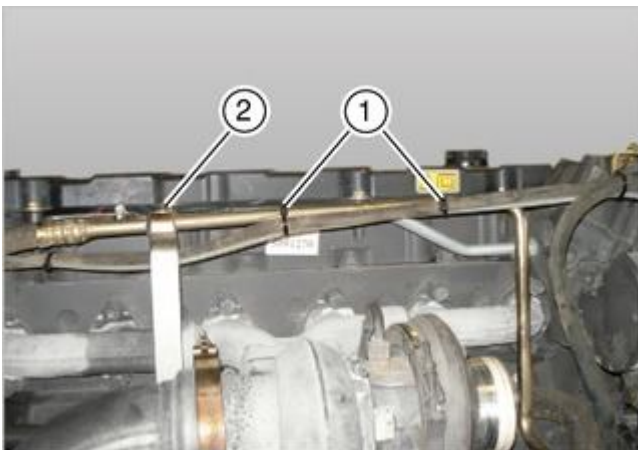

- ▶ Remove cable band (1).
- ▶ Unscrew clamp (2).



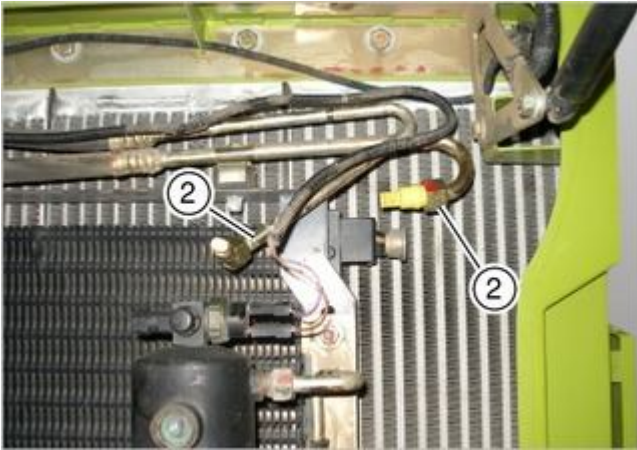
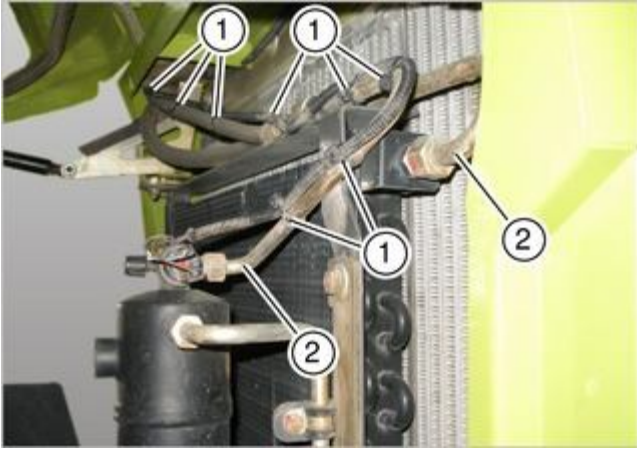

- ▶ Remove cable band (1).
- ▶ Unscrew pipes (2) and plug them with a plug.

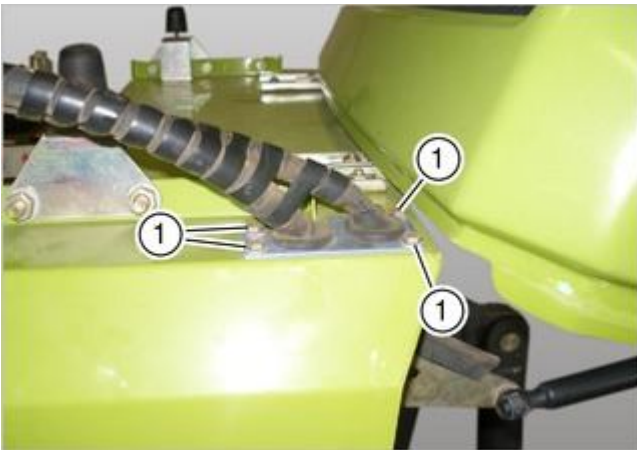

- ▶ Unscrew bolts (1).

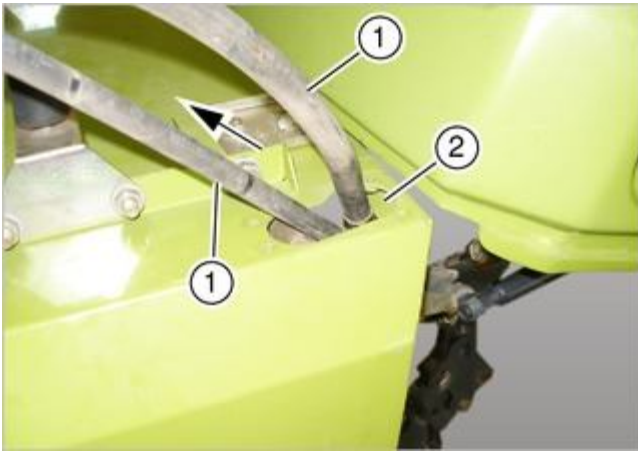

- ▶ Pull out hoses (1) through opening (2) in the direction of the arrow and set aside.

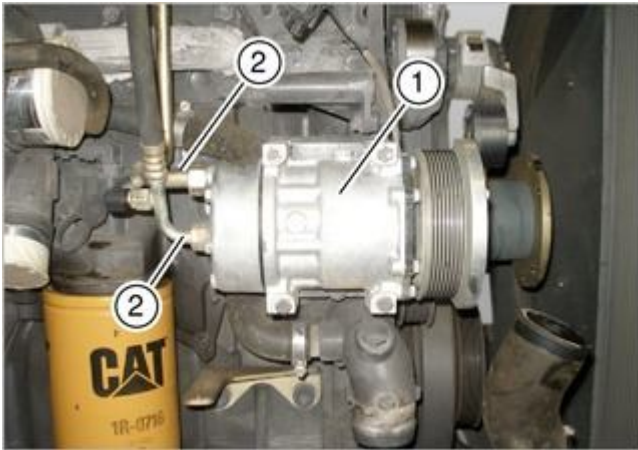

- ▶ Unscrew air conditioner compressor (1).
  - ▶ Do **not** unscrew hoses (2).



- ▶ Put the air conditioner compressor (1) aside along with the lines and fix it.

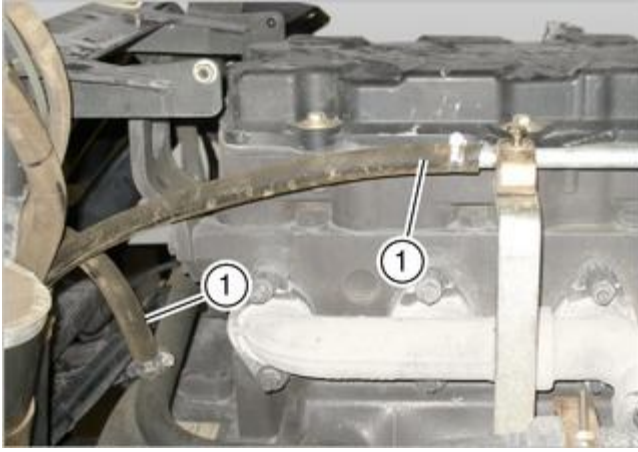

- ▶ Unscrew hoses (1) and close both sides with a plug.

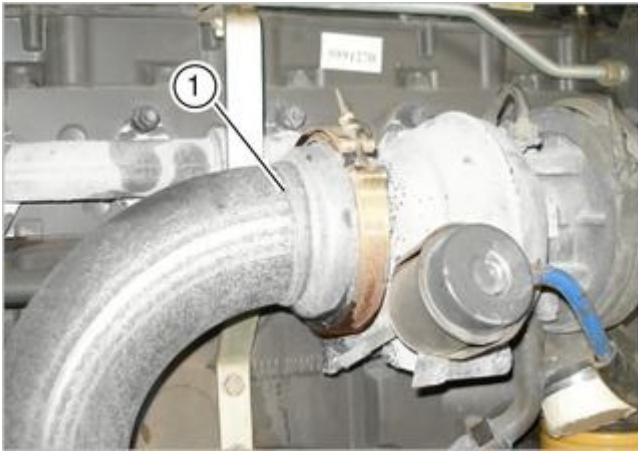

- ▶ Unscrew pipe (1) and plug it with a plug.

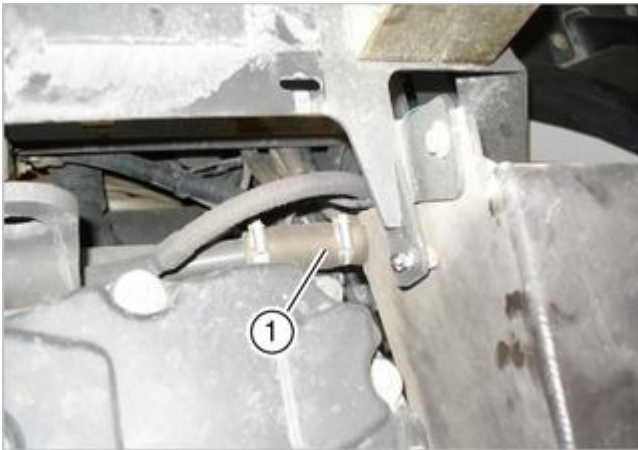

### **On TRAC / TRAC VC**

- ▶ Unscrew hose (1) and close both sides with a plug.



### On TRAC / TRAC VC

- ▶ Mark and disconnect cable from connector (Z032).

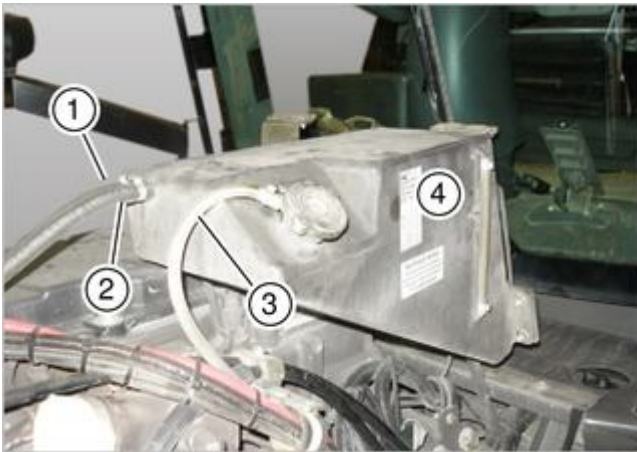

### On TRAC / TRAC VC

- ▶ Remove hoses (1), (2) and (3) and seal with plugs.
- ▶ Remove compensating tank (4).



- ▶ Unscrew bracket (1).



- ▶ Unscrew bracket (1).
- ▶ Unscrew clamp (2).
- ▶ Unscrew bracket (3).
- ▶ Disconnect connector (4).
- ▶ Remove wiring loom (5) and put it aside.

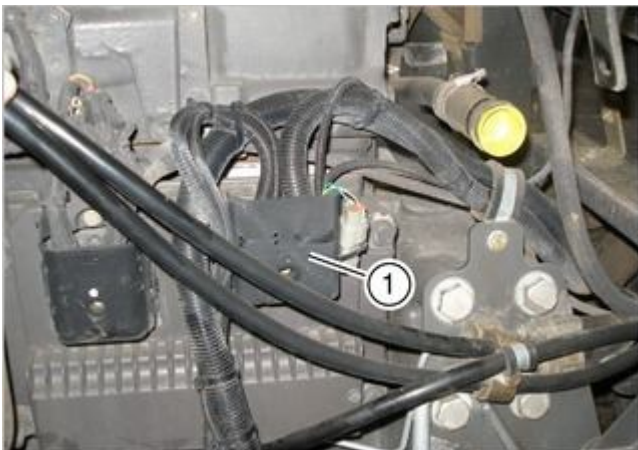

- ▶ Unscrew connector (1) from module (A015).



- ▶ Unscrew hose (1) and close both sides with a plug.

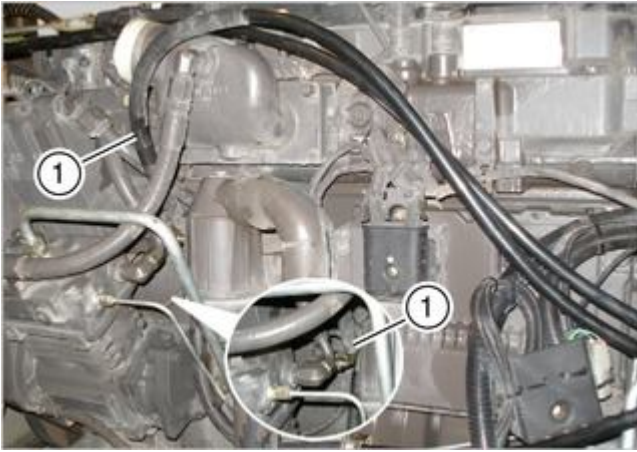

- ▶ Unscrew hose (1) and close both sides with a plug.



- ▶ Unscrew clamp (1).



- ▶ Unscrew clamp (1).

**Buy Now**



Our support email:

[ebooklibonline@outlook.com](mailto:ebooklibonline@outlook.com)