

Mega 400-V

Operation and Maintenance Manual

022-00016AE

Serial Number 1001 and Up

March 2001

Daewoo reserves the right to improve our products in a continuing process to provide the best possible product to the market place. These improvements can be implemented at any time with no obligation to change materials on previously sold products. It is recommended that consumers periodically contact their distributors for recent documentation on purchased equipment.

This documentation may include attachments and optional equipment that is not available in your machine's package. Please call your distributor for additional items that you may require.

Illustrations used throughout this manual are used only as a representation of the actual piece of equipment, and may vary from the actual item.

TABLE OF CONTENTS

Safety	1-1
To the Operator of a Daewoo Wheel Loader	1-1
General Safety Essentials	1-2
Location of Safety Labels	1-3
Unauthorized Modifications	1-11
Work-Site Precautions.....	1-11
Operation.....	1-13
Equipment	1-18
Maintenance.....	1-22
Shipping and Transportation.....	1-24
Operating Controls	2-1
Component Locations	2-2
Control Identification.....	2-4
Steering Console and Pedals	2-5
Transmission Display	2-12
Front Instrument Panel	2-14
Right Side Switch Panel	2-23
Various Cabin Locations.....	2-33
Heater and Air Conditioner Operation	2-37
Stereo.....	2-41
Seat Adjustment	2-45
Seat Belt.....	2-47
Door side latch	2-48
Fuse Box/Relay	2-49
Window Glass Breaking Tool.....	2-52
Operation	3-1
Instrument Panel Control Functions	3-1
New Machine Break-in Procedures.....	3-1

Engine Start and Stop	3-2
Machine Travel	3-11
Machine Shutdown.....	3-13
Additional Braking	3-15
Boom Raise Kickout	3-16
Bucket Angle Indicator	3-16
Boom Lower Kickout (Option).....	3-17
Adjustment of Bucket Position Switch	3-17
Towing Machine.....	3-18
If Engine Stalls While Traveling	3-19
Allowable Water Depth	3-19

Inspection, Maintenance and Adjustment..... 4-1

Preventive Maintenance	4-1
Table of Recommended Lubricants	4-3
Fluid Capacities.....	4-5
Maintenance Intervals	4-6
10 Hour / Daily Service	4-8
50 Hour / Weekly Service.....	4-18
250 Hour / Monthly Service.....	4-25
500 Hour / 3 Month Service	4-32
1,000 Hour / 6 Month Service	4-36
1,500 Hour / 9 Month Service	4-41
2,000 Hour / Annually Service.....	4-43
Severe Conditions Maintenance.....	4-47
General Maintenance	4-48
Parking Brake Adjustment	4-50
Check Hydraulic Pressures	4-51
Tires and Wheels	4-54
Electrical System.....	4-56
Bolt Torque Chart	4-57
Long Term Storage.....	4-58

Transportation	5-1
Loading Machine on a Trailer	5-1
Summary of Safety Precautions for Lifting	5-2
Troubleshooting	6-1
Engine	6-1
Hydraulic System	6-4
Travel System	6-6
Steering	6-11
Braking	6-12
Electrical System.....	6-12
Specifications	7-1
General Specifications	7-1
Working Range and Dimensions	7-2
Working Capacities	7-4
Approximate Weight of Workload Materials	7-4
Index	8-1

SAFETY

TO THE OPERATOR OF A DAEWOO WHEEL LOADER



Improper use of wheel loader could cause serious injury or death. Before operating wheel loader, or performing maintenance, operator or technician must read and understand entire Operation and Maintenance Manual.

Any operation, maintenance, traveling or shipping methods that do not follow safety guidelines printed in this Manual could cause serious injury or death.

Please respect the importance of taking responsibility for your own safety, and that other people who may be affected by your actions.

Safety information on the following pages is organized into the following topics.

1. "General Safety Essentials" on page 1-2
2. "Location of Safety Labels" on page 1-3
3. "Unauthorized Modifications" on page 1-11
4. "Work-Site Precautions" on page 1-11
5. "Operation" on page 1-13
6. "Equipment" on page 1-18
7. "Maintenance" on page 1-22
8. "Shipping and Transportation" on page 1-24



SAFETY ALERT SYMBOL



Be Prepared – Get to Know All Operating and Safety Instructions.

This is the Safety Alert Symbol. Wherever it appears – in this manual or on safety signs on the machine – you should be alert to potential for personal injury or accidents. Always observe safety precautions and follow recommended procedures.

LEARN SIGNAL WORDS USED WITH SAFETY ALERT SYMBOL

Words "**CAUTION**," "**WARNING**," and "**DANGER**" used throughout this manual and on labels on machine indicate hazards or unsafe practices. All three statements indicate that safety is involved. Observe precautions indicated whenever you see the Safety Alert "Triangle," no matter which signal word appears next to the "Exclamation Point" symbol.



CAUTION!

Indicates a hazardous situation that, if not avoided, could result in minor or moderate injury. It may also be used to alert against a generally unsafe practice.



WARNING!

Indicates a hazardous situation that, if not avoided, could result in serious injury or death. It may also be used to alert against a highly unsafe practice.



DANGER!

Indicates a hazardous situation that, if not avoided, is very likely to cause death or extremely serious injury. It may also be used to alert against equipment that may explode or detonate if handled or treated carelessly.

GENERAL SAFETY ESSENTIALS

ACCESSORY APPLICATIONS

Wheel loader has been designed primarily for moving earth with a bucket. For use as a grapple or for other object handling, contact Daewoo. Lifting-work applications are permitted in approved lift configuration, to rated capacity only, with no side-loading (unless prohibited by local regulation). Do not use machine for activities for which it was not intended. Do not use bucket for lifting work, unless lift slings are used in approved configuration.

LOCATION OF SAFETY LABELS

Always keep these labels clean. If they are lost or damaged, attach them again or replace them with a new label. Make sure replacement parts have current labels.

There are other labels in addition to safety labels that follow so handle them in the same way. Safety labels may be available in languages other than English. To find out what labels are available, contact your Daewoo distributor.

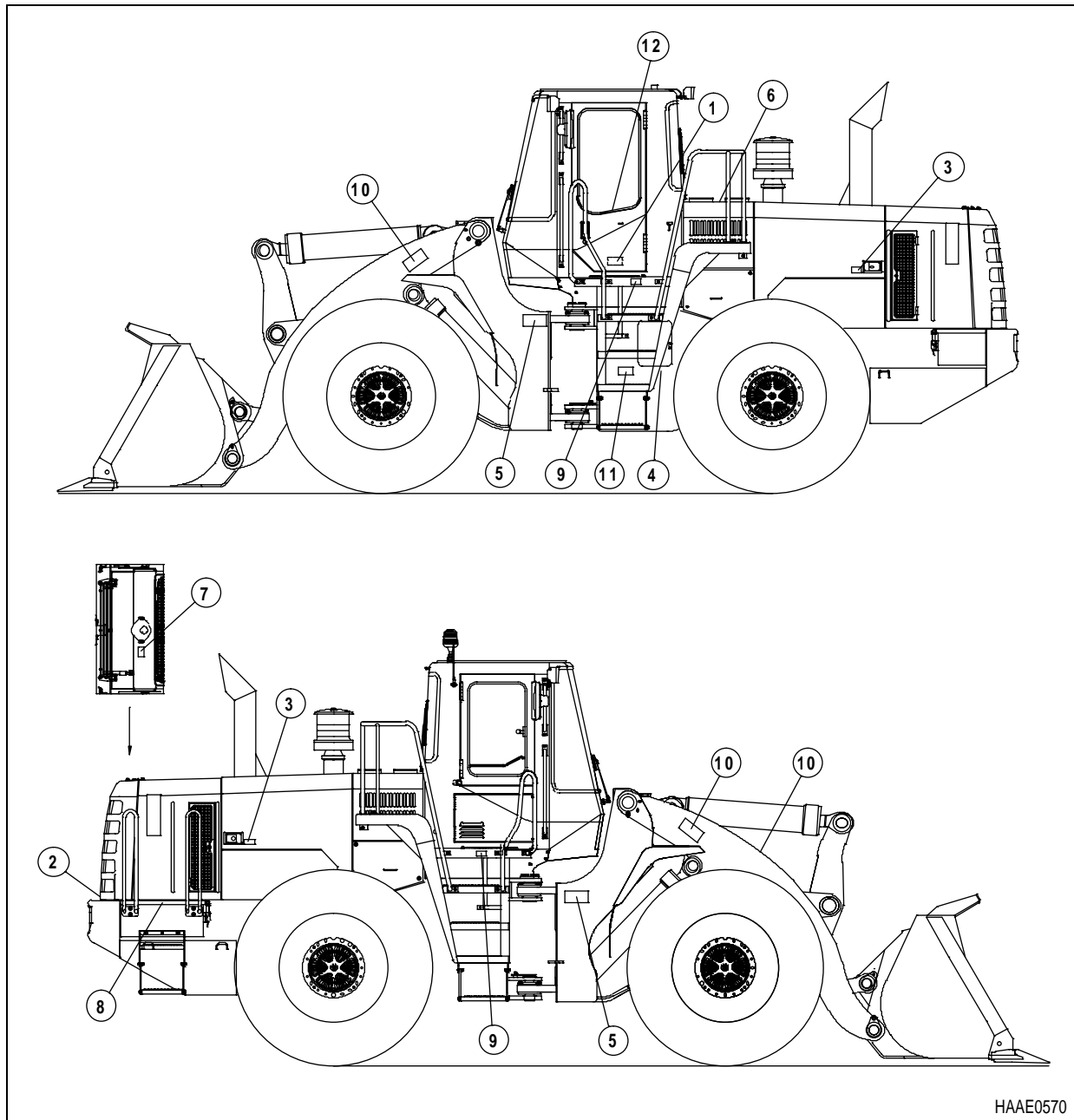

1. WARNING FOR OPERATION, INSPECTION AND MAINTENANCE (4190-2545, 190-00092)

 **CAUTION!**

- Read manual and labels before operation and maintenance. Follow instructions and warnings in manual and on labels on machine.
- Sound horn to alert people nearby before operating, and make sure all persons are clear of area.
- Always make sure when leaving operator's seat to:
 - Lower bucket or other working tools to ground.
 - "LOCK" transmission selector in "NEUTRAL."
 - Set park brake.
 - Turn key switch "OFF." Remove key from switch.
- If hydraulic components and units are ABNORMAL, consult nearest DAEWOO dealer or authorized service shop. Do not attempt to make an overhaul.

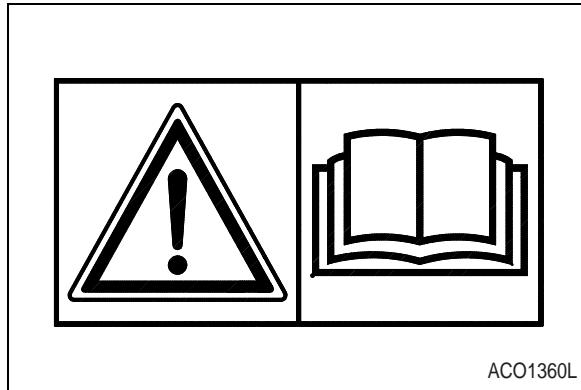

2. WARNINGS FOR ENGINE FAN (2190-2525, 190-00557)

 **WARNING!**

Keep your hands away from the fan during operation. Entanglement in the fan can cause serious injury.

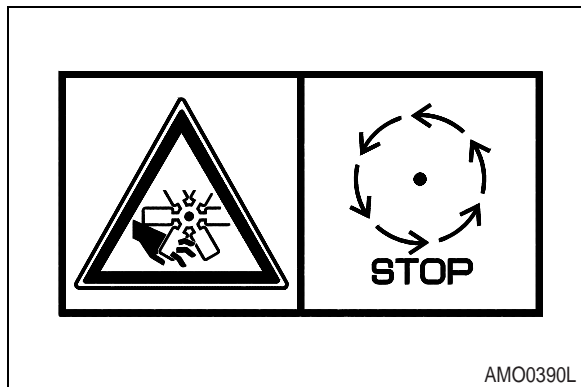

3. WARNINGS WHEN OPENING ENGINE HOOD (2190-2525, 190-00095)



WARNING!

Before opening bonnet, stop engine.

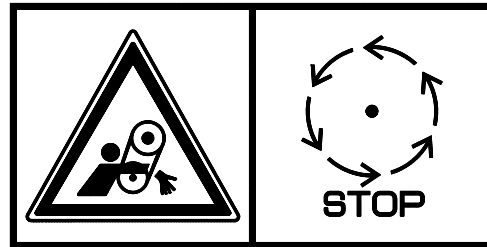

ACO1420L

4. WARNING FOR HANDLING ACCUMULATOR (2190-2528, 190-00099)

 WARNING!
Explosion hazard: <ul style="list-style-type: none">• Keep away from flame.• Do not weld or drill.
<small>ACO1480L</small>



Accumulator

Wheel loader pilot control system is equipped with an accumulator. Accumulator will store a pressure charge that may enable hydraulic controls to be activated for a brief period of time after engine has been shut down. Activation of any controls may enable selected function to operate under force of gravity.

 CAUTION!
Any raised attachment will lower to ground if accumulator holds a charge.

When shutting machine down, lower front attachment to ground. After engine has been shut down, turn key to "ON" position and move joystick controls to release pressure in accumulator. Remove key.

IMPORTANT
Refer to Shop Manual for service procedures. Do not release any pilot lines until pressure within accumulator has been released.

5. KEEP OUT OF STEERING TURN AREA (4190-1992, 190-00120)

 **DANGER!**

Keep out of steering turn area.



AMO0410L

6. WARNING FOR HIGH TEMPERATURE HYDRAULIC OIL (2190-2529, 190-00097)

 **WARNING!**

HYDRAULIC OIL

To prevent hot oil from spurting out:

- Turn engine off.
- Allow oil to cool.
- Slowly loosen cap to relieve pressure before removing.

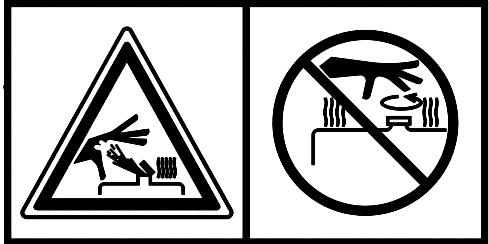

ACO1410L

7. WARNING FOR HIGH TEMPERATURE COOLANT (2190-2531, 190-00097)



WARNING!

To prevent hot water from spurting out:

- Turn engine "OFF."
- Allow water to cool.
- Slowly loosen cap to relieve pressure before removing.

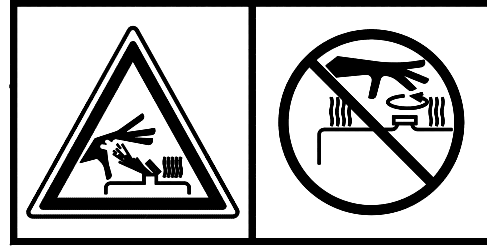

ACO1410L

8. WARNING FOR BATTERY MAINTENANCE (2190-2533, 190-00100)



DANGER!

- Battery fumes can explode. Keep sparks and flames away from batteries.
- Always avoid storing metals like tools or inflammable materials around or on batteries. Explosion or fire can be caused by short circuiting batteries.
- Sulfuric acid in battery is poisonous. It is strong enough to burn skin, eat holes in clothing, and cause blindness if splashed in eyes.

If you spill acid on yourself:

1. Flush your skin with water.
2. Apply baking soda or lime to help neutralize acid.
3. Flush your eyes with water for 10-15 minutes.

Get medical attention immediately.

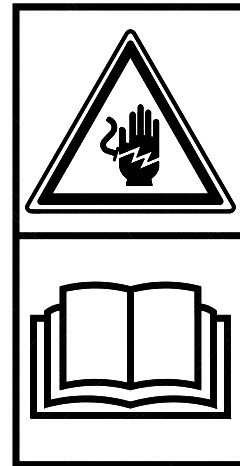

ACO1400L

9. WARNING FOR RIDING ON MACHINE (4190-1989, 190-00107)

 **WARNING!**

For your safety, do not stand on ladder when machine is in motion.

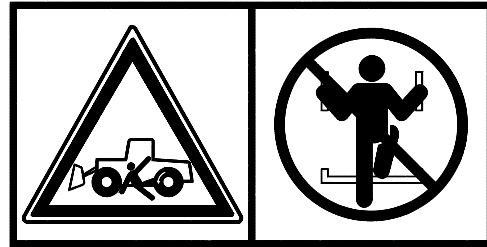

AMO0420L

10. WARNING FOR PERFORMING MAINTENANCE ON FRONT ATTACHMENT (4190-2546, 190-00105)

 **DANGER!**

To avoid injury, securely brace lift arm before disassembly of valve or piping.

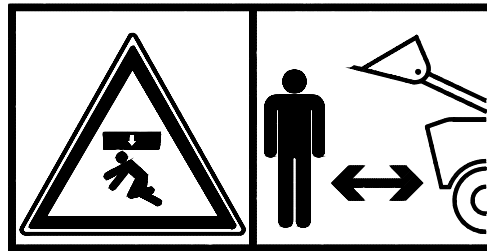

AMO0430L

11. WARNING TO USE SAFETY LOCK (4190-1993, 190-00121)



WARNING!

Safety lock must be in "LOCK" position when servicing pivot area or transporting machine.

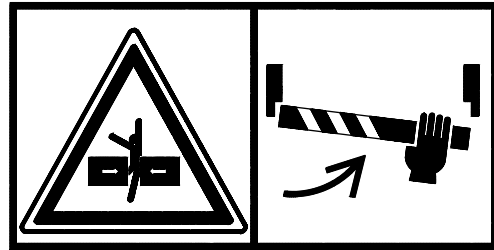

AM00440L

12. WARNING TAG (2190-2549, 190-00098)



WARNING!

Don't touch when performing inspection or maintenance.

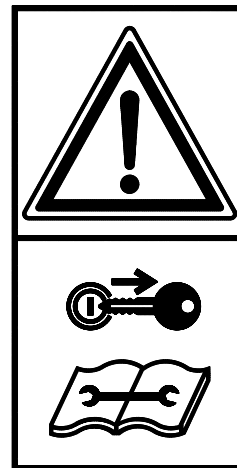

ACO1450L

Buy Now



Our support email:

ebooklibonline@outlook.com