

Page Title	Page Number
ENGINE AND ACCESSORIES - UP TO SERIAL 11-1981	1
ENGINE AND ACCESSORIES	2
CYLINDER BLOCK - AD4.203 ENGINE	3
CRANKSHAFT, PISTONS AND CONNECTING RODS - AD4.203 ENGINE	4
CYLINDER HEAD - AD4.203 ENGINE	5
ROCKER SHAFT - AD4.203 ENGINE	6
AIR INDUCTION AND EXHAUST SYSTEM - AD4.203 ENGINE	7
TIMING GEAR AND CAMSHAFT - AD4.203 ENGINE	8
LUBRICATING OIL SUMP - AD4.203 ENGINE	9
LUBRICATING OIL FILTER AND INTEGRAL COOLER - AD4.203 ENGINE	10
WATER PUMP, THERMOSTAT AND HEAT EXCHANGER - AD4.203 ENGINE	11
LOW PRESSURE FUEL SYSTEM - AD4.203 ENGINE	12
FUEL INJECTION EQUIPMENT (DIESEL) - AD4.203 ENGINE	13
JOINTS AND GASKETS - AD4.203 ENGINE	14
ELECTRICAL EQUIPMENT - UP TO SERIAL 11-1981	15
BATTERY	16
BATTERY	17
GENERATOR-LUCAS - UP TO SERIAL 11-1981	18
ALTERNATOR-LUCAS - FROM SERIAL S165043	19
ALTERNATOR-LUCAS	20
GUARDS PTO AND ALTERNATOR	21
ALTERNATOR POSITIONER - FROM 12-1981	22
STARTER-LUCAS	23
RADIATOR	24
FAN	25
FUEL TANK AND ATTACHMENTS	26
FUEL FILTERS AND PIPES	27
FUEL FILTER	28
AIR FILTER	29
EXHAUST SYSTEM	30
HAND AND FOOT THROTTLE CONTROLS	31
THROTTLE CONTROLS	32
SINGLE CLUTCH	33
CLUTCH PEDAL AND LINKAGE - UP TO SERIAL NUMBER	34
CLUTCH PEDAL AND LINKAGE - FROM SERIAL NUMBER	35
8 SPEED SYNCHROMESH TRANSMISSION-HOUSING	36
8 SPEED SYNCHROMESH TRANSMISSION-CONTROL	37
8 SPEED SYNCHROMESH TRANSMISSION-MAIN SHAFT	38
SYNCHRO	39
8 SPEED SYNCHROMESH TRANSMISSION-COUNTERSHAFT	40
8 SPEED SYNCHROMESH ZF TRANSMISSION-HOUSING	41
8 SPEED SYNCHROMESH TRANSMISSION-SHIFT CONTROL - SYNCHRO- ZF	42
8 SPEED SYNCHROMESH ZF TRANSMISSION-FORK AND GEARSHIFT RAIL	43
8 SPEED SYNCHROMESH ZF TRANSMISSION-MAIN SHAFT	44
8 SPEED SYNCHROMESH ZF TRANSMISSION-SYNCHROMESH	45
8 SPEED SYNCHROMESH ZF TRANSMISSION-COUNTER SHAFT	46
12 SPEED TRANSMISSION-HOUSING - SYNCHRO- ZF	47
12 SPEED TRANSMISSION-SHIFT CONTROL - SYNCHRO- ZF	48
12 SPEED TRANSMISSION-FORK AND GEAR SHIFTRAIL - SYNCHRO- ZF	49
12 SPEED TRANSMISSION-INPUTSHAFT - SYNCHRO- ZF	50
12 SPEED TRANSMISSION-MAIN SHAFT - SYNCHRO- ZF- UP TO SERIAL NUMBER	51
12 SPEED TRANSMISSION-COUNTERSHAFT - SYNCHRO- ZF- UP TO SERIAL 02/83	52
12 SPEED TRANSMISSION-COUNTERSHAFT - SYNCHRO- ZF- FROM SERIAL 03/83	53
12 SPEED TRANSMISSION-MAIN SHAFT - SYNCHRO ZF FROM SERIAL NU...- UP TO SERIAL NUL1670 21	54
12 SPEED TRANSMISSION-MAIN SHAFT - SYNCHRO- ZF- FROM SERIAL L167022	55
EPICYCLIC UNIT-NORMAL DUTY	56
EPICYCLIC UNIT-HEAVY DUTY	57
PTO SHAFT - WITH IPTO	58
PTO-CONTROL	59
IPTO-PIPES AND COVER	60
IPTO-CLUTCH AND VALVES	61
IPTO-CLUTCH AND VALVES - UP TO SERIAL NO	62
IPTO-CLUTCH AND VALVES - FROM SERIAL NUMBER	63
REAR AXLE-SPACER	64
REAR AXLE CENTRE HOUSING	65
REAR AXLE-ATTACHMENTS	66

TABLE OF CONTENT

REAR AXLE-DIFFERENTIAL	67
REAR AXLE-DIFFERENTIAL LOCK MECHANISM	68
REAR AXLE- DIFFERENTIAL LOCK PEDAL - FROM SERIAL NUMBER	69
REAR AXLE-HOUSING	70
DISC BRAKES - 3 DISC	71
BRAKE PEDALS AND LINKAGE	72
BRAKE PEDALS AND LINKAGE - UP TO SERIAL NUMBER	73
BRAKE PEDALS AND LINKAGE - FROM SERIAL NUMBER	74
BRAKE PEDALS AND LINKAGE - ITALY-UK-EE	75
BRAKE PEDALS AND LINKAGE - FROM SERIAL DU 10/1981- WITH HANDBRAKE	76
HANDBRAKE	77
POWER ASSISTED VARIABLE TRACK WHEEL	78
POWER ASSISTED VARIABLE TRACK WHEEL	79
FRONT WHEELS	80
FRONT AXLE - WHEEL HUB	81
FRONT AXLE	82
AXLE SUPPORT - UP TO SERIAL NO	83
AXLE SUPPORT - FROM SERIAL NUMBER	84
STEERING WHEEL	85
STEERING GEAR - BOX	86
STEERING GEAR - POWER STEERING	87
STEERING GEAR	88
STEERING LINKAGE	89
STEERING HYDRAULIC LINES - POWER STEERING	90
STEERING HYDRAULIC LINES - POWER STEERING	91
STEERING PUMP-AIR EQUIPEMENT	92
STEERING CYLINDER - CYLINDER-UP TO 12-83	93
STEERING CYLINDER - FROM SERIAL 01/84	94
POWER STEERING VALVE - UP TO SERIAL NO	95
POWER STEERING VALVE - FROM SERIAL NUMBER	96
HYDRAULIC PUMP DRIVE	97
HYDRAULIC PUMP-SINGLE-PLESSEY	98
HYDRAULIC PUMP-DUAL-AIR EQUIPMENT	99
HYDRAULIC PUMP-DUAL-AIR EQUIPMENT	100
HYDRAULIC PUMP-DUAL-AIR EQUIPMENT	101
INTERNAL LINES - AUXILIARY HYDRAULIC	102
INTERNAL LINES - AUXILIARY HYDRAULIC- WITH BREATHING FILTER	103
INTERNAL LINES - 8 SPEED - 12 SPEED	104
INTERNAL LINES - WITH AUXILIARY PUMP	105
OIL FILTER	106
OIL FILTER - FRONT HOSE-WITHOUT OIL COOLER- UP TO SERIAL NO...	107
HYDRAULIC LINE - MICRONIC FILTRATION- - WITHOUT OIL COOLER- FROM SERIAL NUMBER	108
OIL FILTER - REAR PIPE- UP TO SERIAL	109
OIL COOLER - MICRONIC FILTRATION- FROM SERIAL	110
DISTRIBUTOR - KONTAK	111
DISTRIBUTOR - KONTAK-DELIVERY	112
HYDRAULIC PUMP-BODY SHAFT PISTON	113
HYDRAULIC PUMP-OSCILLATOR VALVE	114
HYDRAULIC PUMP-STRAINER UNIT	115
HYDRAULIC PUMP-PRESSURE CONTROL VALVE	116
HYDRAULIC PUMP-STRAINER UNIT - WITH BREATHING FILTER	117
BREATHING FILTER	118
HYDRAULIC LIFT COVER	119
DRAFT AND POSITION CONTROLS	120
QUADRANT AND CONTROL LEVERS - CONTROL SHAFT	121
RESPONSE CONTROLS	122
LIFT ARMS	123
LIFT ARMS - DRAFT AND POSITION CONTROLS	124
LIFT ARMS - RAM-UP TO 12-81	125
LIFT ARMS - RAM-FROM 12-81	126
TOP LINKS - UPPER LINK-SCALE	127
LOWER LINKS - LEVELLING BOX	128
LOWER LINKS - BOTTOM BAR	129
LOWER LINKS - CHAIN	130
LOWER LINKS - STAY-HITCH BAR	131
FRONT HITCH	132
SHEET METAL-GRILLE	133
SHEET METAL-HOOD	134

TABLE OF CONTENT

SHEET METAL-INSTRUMENT PANEL	135
SHEET METAL-INSTRUMENT PANEL - INSTRUMENT CHROME- UP TO SERIAL	136
SHEET METAL-INSTRUMENT PANEL - INSTRUMENT BLACK- FROM SERIAL	137
SHEET METAL-INSTRUMENT PANEL - INSTRUMENTS	138
SHEET METAL-SHEEL FENDERS	139
SAFETY FRAME	140
FOOTSTEP	141
SEAT-SABLE - UP TO SERIAL NO J251044	142
SEAT-SABLE	143
SEAT-BOSTROM - XL BALTIC	144
SEAT-BOSTROM - XH BALTIC	145
TRANSFERS	146
SPEED CHARTS	147
SPEED CHARTS	148
WIRING - FROM 12-1981	149
WIRING - FROM SERIAL NO J215046	150
WIRING	151
REAR LIGHTING EQUIPMENT - SIGNALLING	152
ELECTRICAL WIRING - HORN	153
FRONT LIGHTING EQUIPMENT	154
REAR LIGHTING EQUIPMENT - WORKING LIGHT	155
REAR LIGHTING EQUIPMENT - LICENSE PLATE	156

1-0010-100

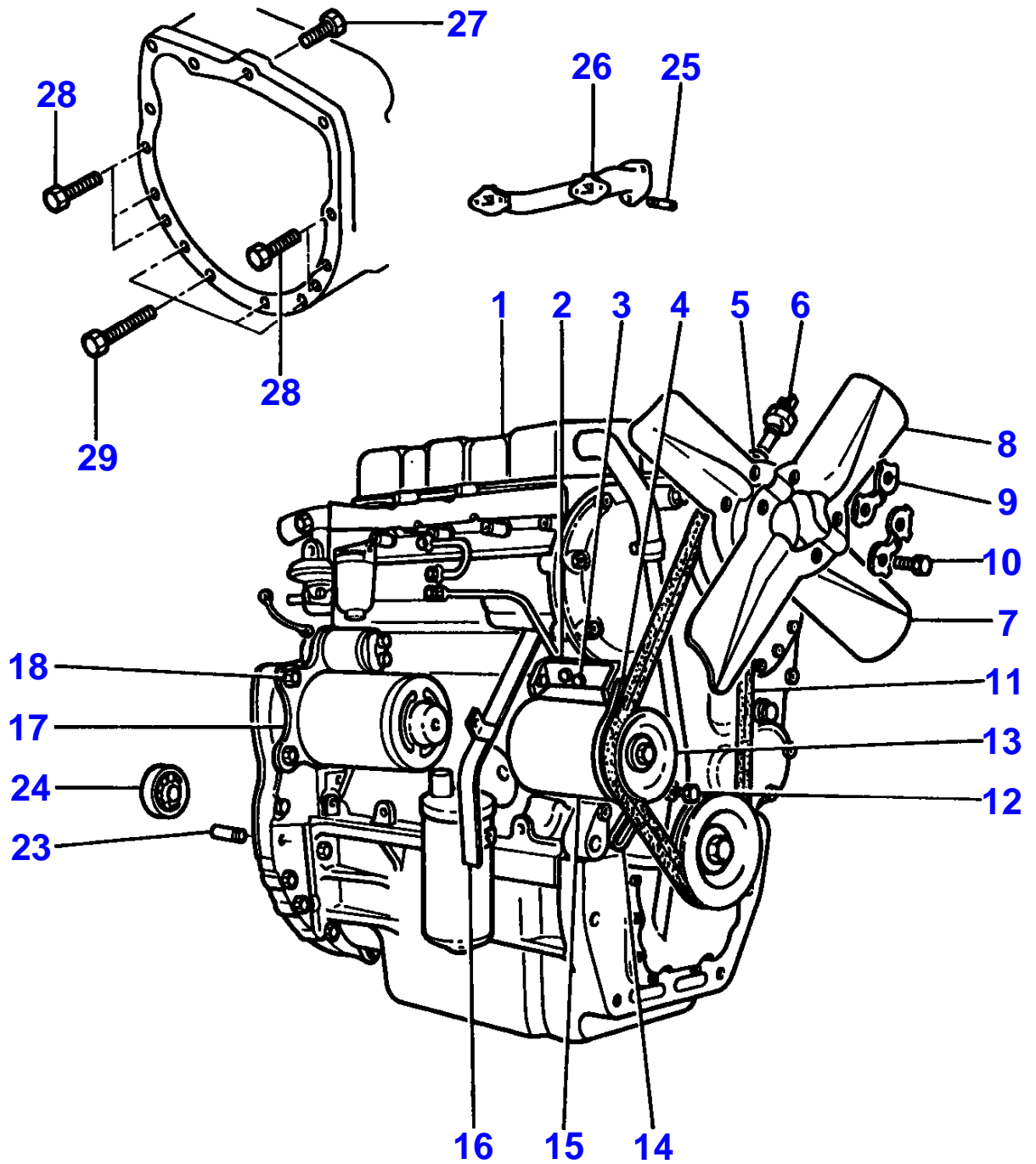

MASSEY FERGUSON

MF 158 MKIII/158 F TRACTORS - 1637074

1637074

ENGINE AND ACCESSORIES - UP TO SERIAL 11-1981

1

Item	Part Number	Qty	Description	Comments
				UP TO SERIAL 11-1981
1	1808128M3	1	Engine	AD4.203 PEL - JE21586
2	962182M1	1	Bearer	
3	353679X1	2	Screw Unc	
	375703X1	3	Washer	
	353446X1	3	Lock Washer	
	353518X1	1	Screw Unf	
4	353521X1	2	Bolt Unf	
	353916X1	2	Nut Unf	
	353446X1	2	Lock Washer	
5	2411157	1	Washer	
6	963418M1	1	Gauge	
7	963929M1	1	Blade Fan	
8	963930M1	1	Blade Fan	
9	897057M1	2	Brake	
10	361444X1	4	Screw	
11	962184M2	1	Belt	
12	353681X1	1	Bolt Unc	
	353755X1	1	Washer	
	353446X1	1	Lock Washer	
	355565X1	1	Nut Unc	
13	960028M1	1	Pulley	
14	962183M1	1	Lever	
15		1	Dynamo	See Page - Reference Number 18/001 LUCAS
16	907500M91	1	Cowl	
17		1	Startermotor	See Page - Reference Number 23/001 LUCAS
18	362501X1	2	Screw	
	361773X1	1	Screw	
	353432X1	3	Lock Washer	
23	191314M1	2	Centraliser	
24	828123M1	1	Bearing Assy	
25	731656M1	3	Stud	
26	732813M1	1	Manifold	
27	362479X1	1	Screw	
28	362491X1	7	Screw	
29	362726X1	4	Screw	

1-0010-095

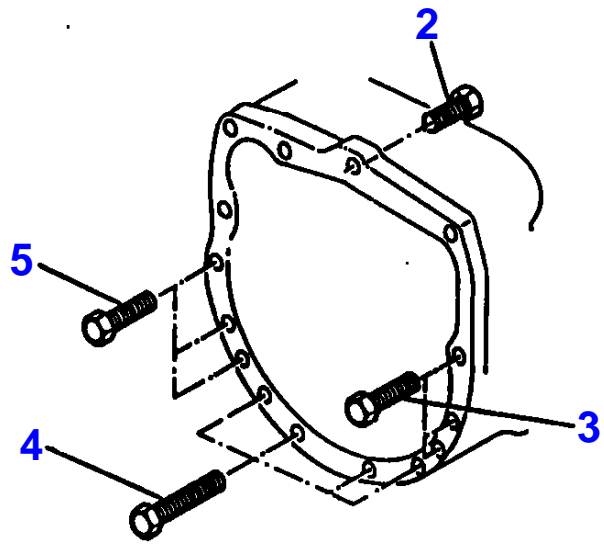
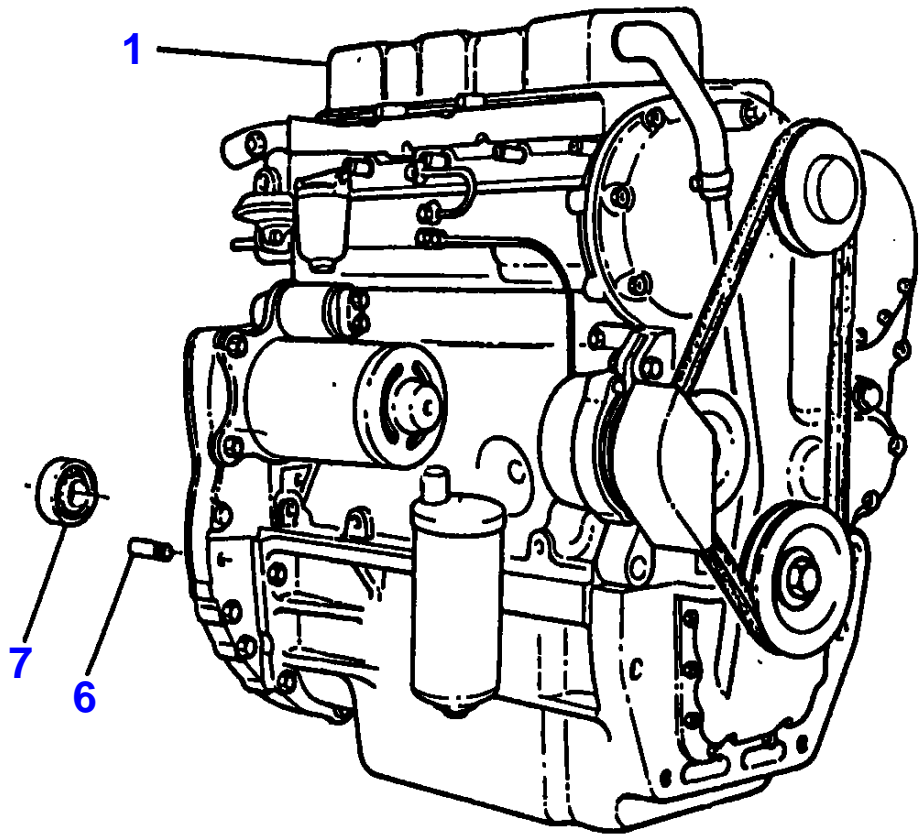

L

MASSEY FERGUSON**MF 158 MKIII/158 F TRACTORS - 1637074**

1637074

ENGINE AND ACCESSORIES

2

Item	Part Number	Qty	Description	Comments
1	1808128M3	1	Engine	AD4.203 PEL - JE21586
2	362479X1	1	Screw	
3	362491X1	4	Screw	
4	353714X1	4	Bolt Unc	
5	362491X1	3	Screw	
6	191314M1	2	Centraliser	
7	828123M1	1	Bearing Assy	

J-0560-01M - B

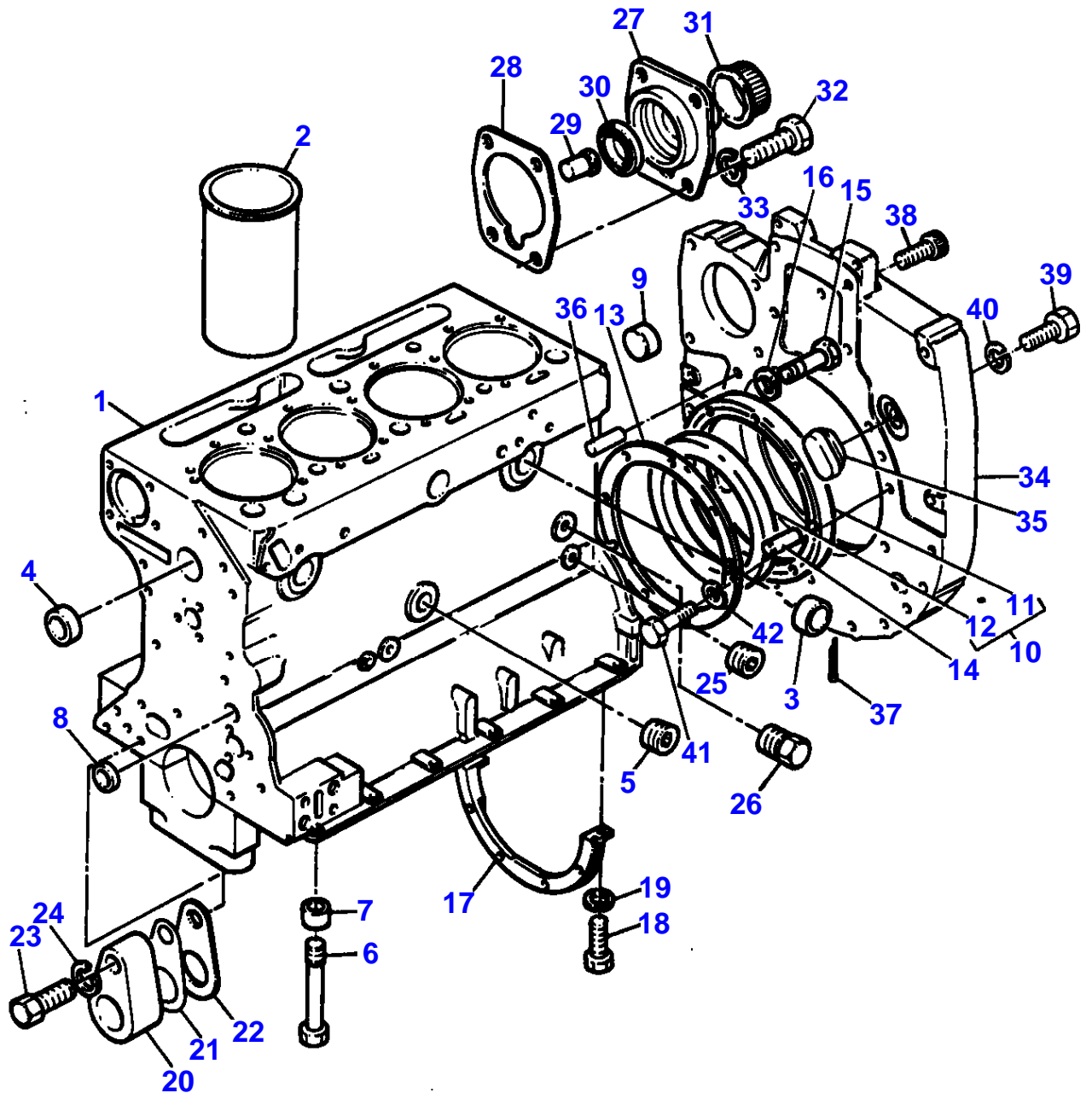

CYLINDER BLOCK - AD4.203 ENGINE

Item	Part Number	Qty	Description	Comments
				AD4.203 ENGINE
1	ZZ 50166	1	Kit,Cyl.Block	Repairs and replaces ZZ50000
2	31358323	4	Liner	(1) (A)
2	31358345	X	Liner	(B)
	31358384	X	Liner	0.010"0,25MM O/S
2	31358357	X	Liner	0.030"0,76MM O/S
3	0650710	6	Plug	(1) Repairs and replaces 0650563
4	0650710	1	Plug	(1)
5	0650588	1	Plug	(1)
6	32181441	10	Screw	(1)
7	33137408	10	Thimble	(1)
8	0650566	2	Plug	
9	0650710	1	Plug	Repairs and replaces 0650563
10	4142V002	1	Housing	
11		1	Housing	(10) Not serviced, order REF.10
12	2418F475	1	Seal	(10)
13	33826111	1	Joint	
14	0350015	2	Dowel	
15	0746255	9	Setscrew	
16	0920003	9	Washer	
17	37353821	1	Bridge Piece	
18	0096232	2	Bolt	
19	0920053	2	Washer	
20	36177511	1	Spacer	
21	36177415	14	Shim	
22	36177409	1	Shim	
23	0096236	1	Bolt	
24	0920053	1	Washer	
25	2431131	2	Plug	
26	32161114	2	Plug	
27	37512621	1	Housing	
28	0490699	1	Joint	
29	33473106	1	Connection	
30	30854	1	Seal	
31	32813106	1	Cap Nut	
32	0746255	4	Setscrew	
33	0920053	4	Washer	
34	37147974	1	Plate	
35	37813113	1	Plug	
36	0350016	2	Dowel	
37	0610045	1	Pin	
38	0720798	2	Screw	
39	0746454	6	Setscrew	
40	0920054	6	Washer	
41	0748613	2	Screw	
42	0920055	2	Washer	

(A)
PRESS FIT

(B)
SLIP FIT

J-0563-01M-B

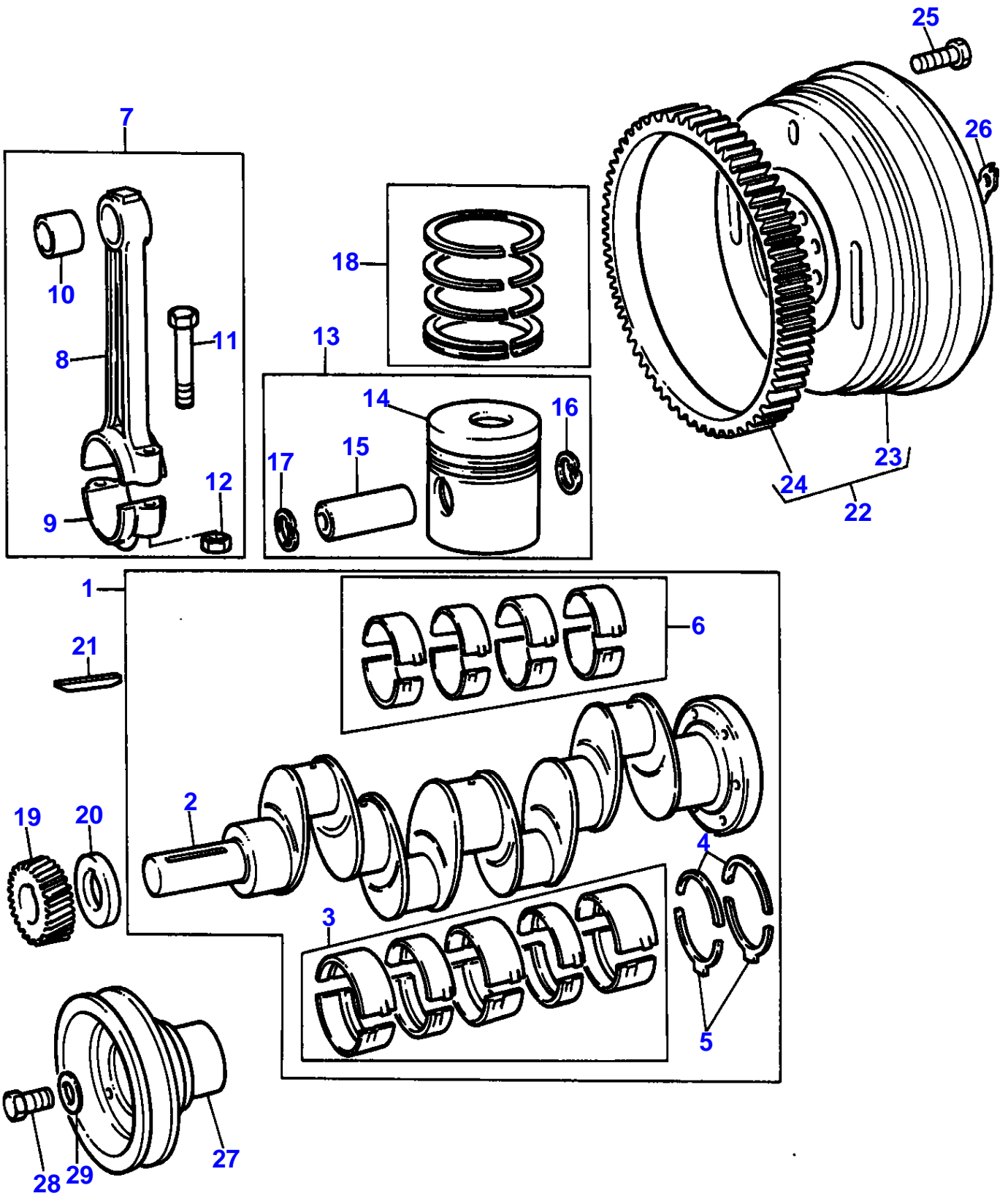

CRANKSHAFT, PISTONS AND CONNECTING RODS - AD4.203 ENGINE

Item	Part Number	Qty	Description	Comments
				AD4.203 ENGINE
1	ZZ 90111	1	Kit, Crankshaft	Repairs and replaces 94441
2		1	Crankshaft	Repairs and replaces 94455
3	68082	1	Kit, Bearing	(1) Not serviced, order REF.1
3	68082A	X	Kit, Bearing	(A) (A) Thickness (-)0.25MM Thickness (-)0.010"
3	68082B	X	Kit, Bearing	(A) Thickness (-)0.50MM Thickness (-)0.020"
3	68082C	X	Kit, Bearing	(A) Thickness (-)0.75MM Thickness (-)0.030"
4	31137211	2	Thrust Washer	(1)
	31137212	X	Washer	Thickness (+)0.19MM Thickness (+)0.0075"
5	31137221	2	Thrust Washer	(1)
	31137222	X	Washer	Thickness (+)0.19MM Thickness (+)0.0075"
6	85035	1	Kit, Bearing	(1) (A)
6	85035A	X	Kit, Bearing	(A) Thickness (-)0.25MM Thickness (-)0.010"
6	85035B	X	Kit, Bearing	(A) Thickness (-)0.50MM Thickness (-)0.020"
6	85035C	X	Kit, Bearing	(A) Thickness (-)0.75MM Thickness (-)0.030"
7	ZZ 90010	4	Kit, Conrod	
8		1	Conrod	(7) Not serviced, order REF.7
9		1	Bearing Cap	(7) Not serviced, order REF.7
10	31134151	1	Bush	(7)
11	0095250	2	Bolt	(7)
12	33221327	2	Nut	(7)
13	68302	4	Kit, Piston	(B)
	89214	X	Kit, Piston	(C)
14		1	Piston	(13) Not serviced, order REF.13
15		1	Piston Pin	(13) Not serviced, order REF.13
16	0170001	1	Circlip	(13)
17	0170001	1	Circlip	(13)
18	41158065	4	Kit, Piston Ring	
19	0410228	1	Gear,Crankshaft	26T
20	0330934	1	Spacer	
21	36271704	1	Woodruff Key	
22	41112797	1	Flywheel	
23		1	Flywheel	(22) Not serviced, order REF.22
24	0410236	1	Starter Ring	(22) Number of teeth/spines 115
25	32162203	6	Screw	
26	0921062	3	Tab Washer	
27	31148677	1	Pulley,Crank	
28	32162312	1	Screw	
29	33125112	1	Washer	

(A)
PRE-FINISHED

(B)
UNTOPPED

MASSEY FERGUSON

MF 158 MKIII/158 F TRACTORS - 1637074

1637074

CRANKSHAFT, PISTONS AND CONNECTING RODS - AD4.203 ENGINE

4

Item	Part Number	Qty	Description	Comments
------	-------------	-----	-------------	----------

				(C) PRE-TOPPED
--	--	--	--	-------------------

J-0566-01M-B

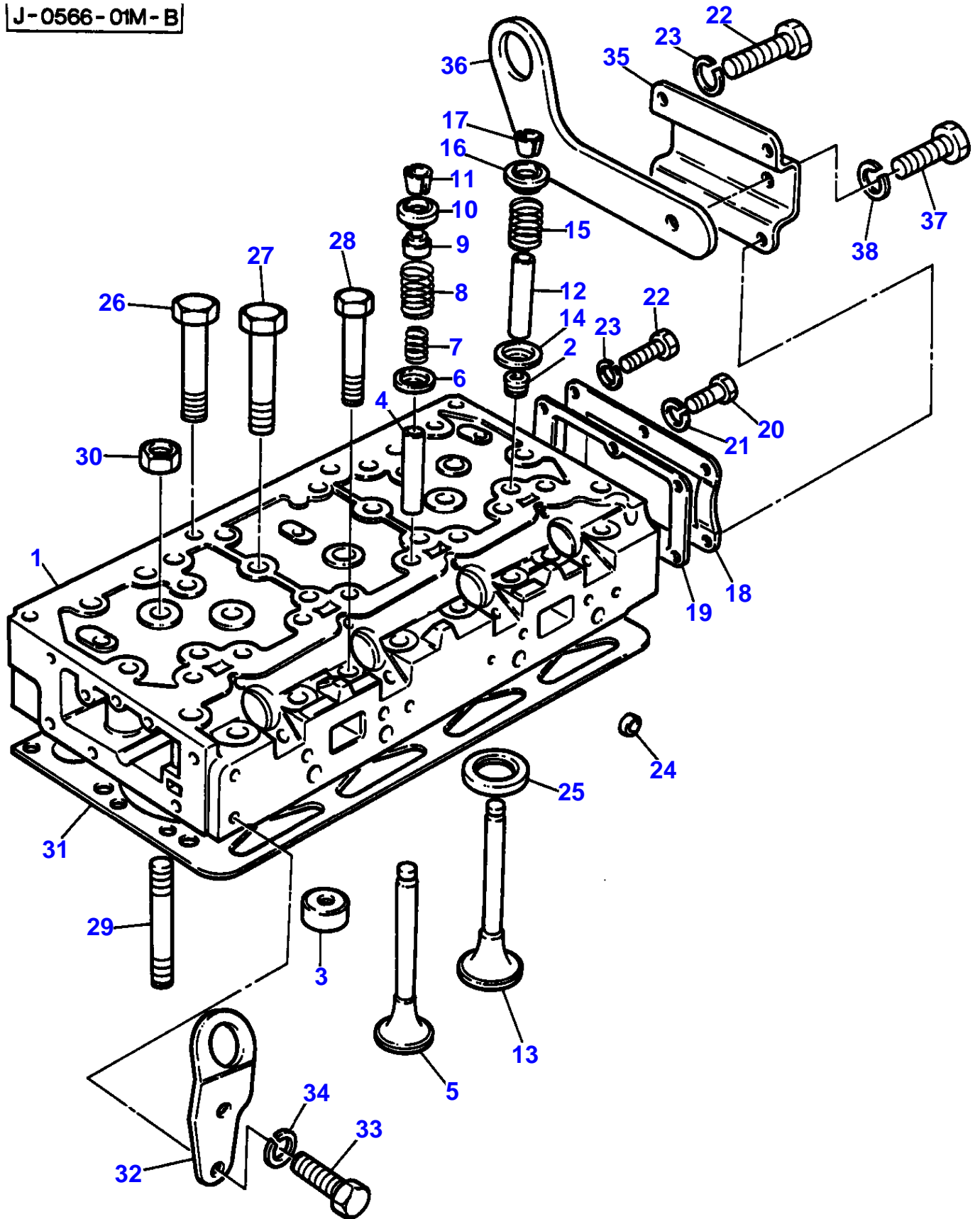

CYLINDER HEAD - AD4.203 ENGINE

Item	Part Number	Qty	Description	Comments
AD4.203 ENGINE				
1	ZZ 80033	1	Kit, Cyl. Head	Up to Serial or Engine Number U527443E
	ZZ 80078	1	Kit, Cyl. Head	(A) From Serial or Engine Number U527444E
2	0650590	4	Plug	(1) Up to Serial or Engine Number U527443E
3	33157143	3	Plug	(1)
4	33261727	4	Guide	(1)
5	31431681	4	Valve Inlet	(1)
6	33177518	4	Washer	(1)
7	0780007	4	Spring	(1)
8	0780006	4	Spring	(1)
9	2415258	4	Seal	(1)
10	33423148	4	Cap	(1)
11	0230001	8	Cotter	(1) (C) Repairs and replaces 33173115
11	0230001	8	Cotter	(D,E)
12	33261723	4	Guide	(1)
13	31431991	4	Valve Exhaust	(1)
14	33415133	4	Washer	(1)
15	0780006	4	Spring	(1)
16	33423148	4	Cap	(1)
17	0230001	8	Cotter	(1) (C) Repairs and replaces 33173115
17	0230001	8	Cotter	(D,E)
18	3612M002	1	Plate	(1)
19	0490485	1	Joint	(1)
20	0746053	4	Bolt	(1) Up to Serial or Engine Number U527443E
20	0746254	4	Setscrew	(1) From Serial or Engine Number U527444E
21	0920052	4	Washer	(1) Up to Serial or Engine Number U527443E
21	0920053	4	Washer	(1) From Serial or Engine Number U527444E
22	0746052	2	Bolt	(1) Up to Serial or Engine Number U527443E
22	0746253	2	Screw	(1) From Serial or Engine Number U527444E
23	0920052	2	Washer	(1) Up to Serial or Engine Number U527443E
23	0920053	2	Washer	(1) From Serial or Engine Number U527444E
24	32417117	4	Plug	Up to Serial or Engine Number U527443E
25	33124428	4	Insert	
26	32181445	4	Screw	
27	32181446	9	Screw	
28	32181447	8	Screw	
29	32524133	2	Stud	
30	33221315	2	Nut	
31	36812138	1	Gasket	
32	3648C004	1	Plate	Repairs and replaces 36475706
33	0746453	2	Setscrew	
34	0920054	2	Washer	
35	36613125	1	Bracket	Up to Serial or Engine Number U527442E
	36613133	1	Bracket	From Serial or Engine Number U527443E
36	36245112	1	Plate	
37	2182110	1	Screw	
38	0920054	1	Washer	

(A)
MAJOR ASSEMBLY-SEE ZZ80104 FOR MINOR ASSEMBLY(INCL UDES REF.5,27,32 ONLY).

(C)
REMOVE AND FIT 0230001

Buy Now



Our support email:

ebooklibonline@outlook.com