

Page Title	Page Number
Hanger	010-0005
Cylinder Head	010-0010
Cylinder Head Cover	010-0015
Inlet Manifold	010-0020
Exhaust Manifold	010-0025
Cylinder Block - 6803	010-0030
Cylinder Block - 6804	010-0035
Cylinder Block - Rear Plate	010-0040
Crankcase - Oil Sump	010-0045
Timing Gear Housing	010-0050
Rocker Shaft And Valves	010-0055
Camshaft	010-0060
Piston	010-0065
Crankshaft - Hydrostatic Transmission	010-0070
Crankshaft - Standard Transmission	010-0075
Lubrication	010-0080
Water Pump	010-0085
Fan	010-0090
Injection	010-0095
Injection - 036714	010-0100
Injection - 036715	010-0105
Injection Pump	010-0110
Injection Pump	010-0115
Kit, Engine Overhaul	010-0120

3-IS10-004-A

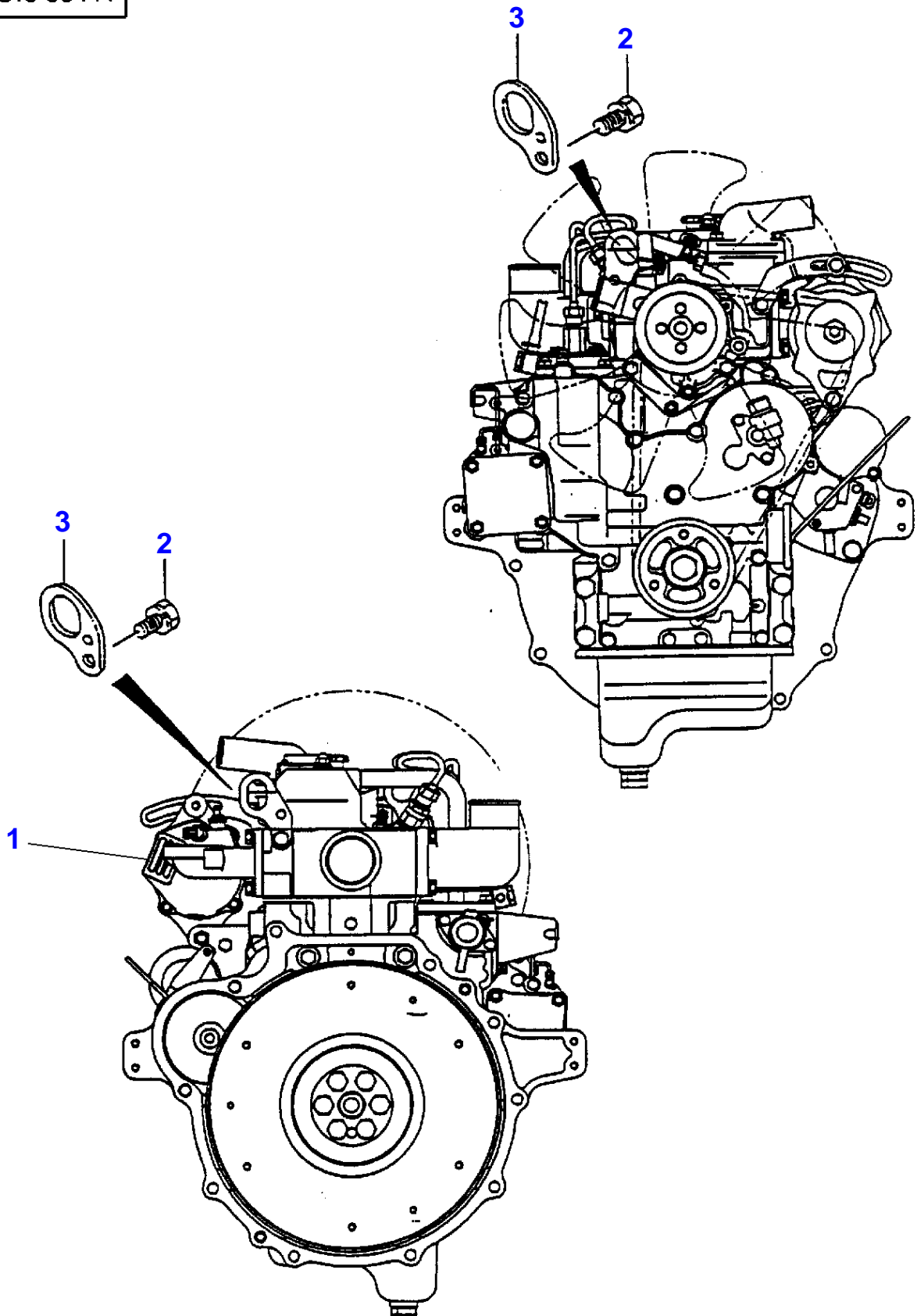

Hanger

Item	Part Number	Qty	Description	Comments
1	3710106M91	1	Engine	[A]
	3710107M91	1	Engine	[B]
2	3704341M1	2	Bolt	
3	3710190M2	2	Hanger	

FOOTNOTE [A] HYDROSTATIC ENGINE

FOOTNOTE [B] MECHANICAL ENGINE

3-IS01-010-A

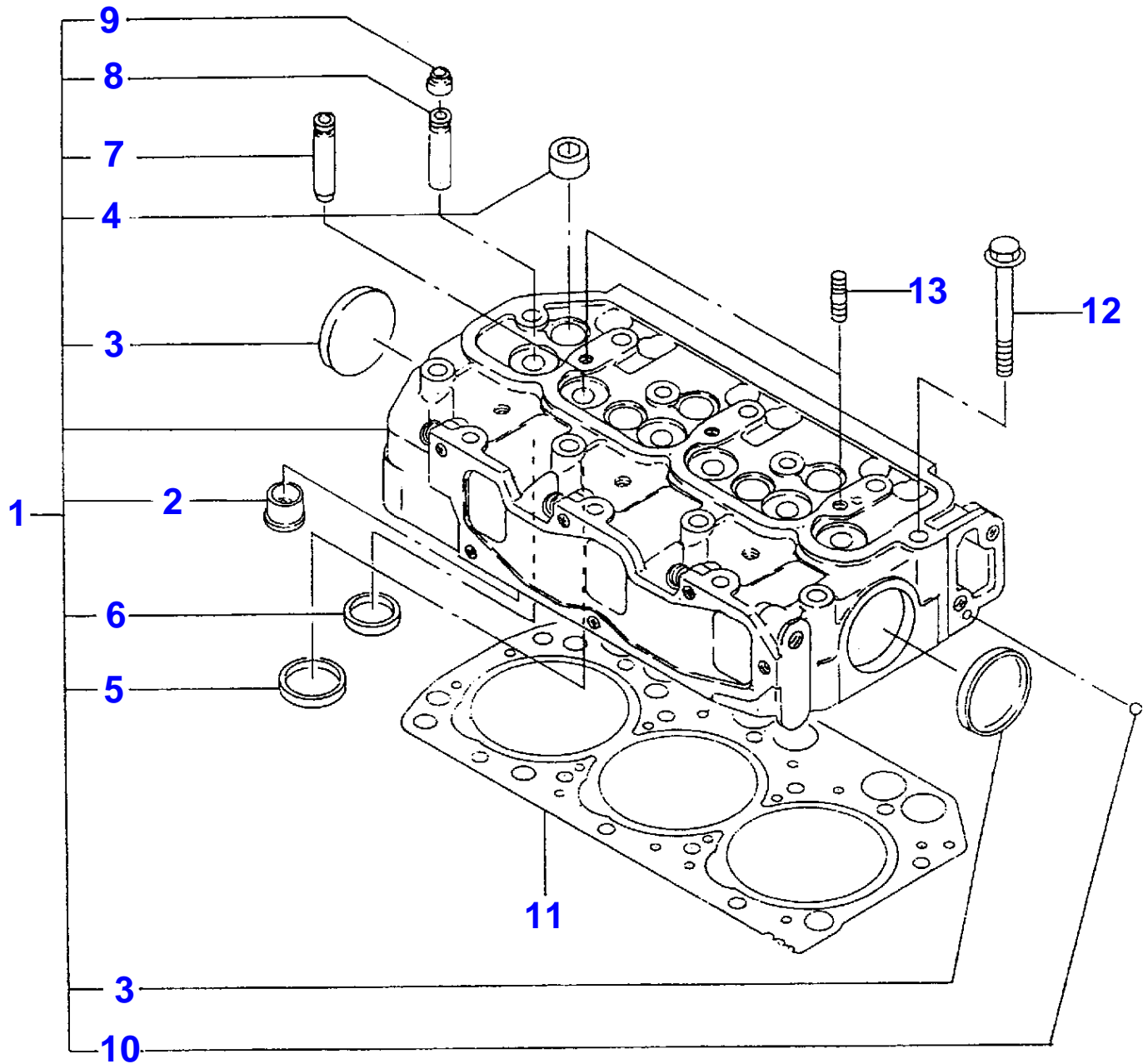

Cylinder Head

Item	Part Number	Qty	Description	Comments
1	3710546M93	1	Cylinder Head	015035
	3605404M91	1	Cylinder Head	015036
2	3710549M91	3	Glow Plug	015035
	3754116M91	3	Glow Plug	015036
3	3710542M1	2	Cup	
4	3707877M2	5	Plug	
5	3704530M1	3	Valve Seat	
6	3704529M1	3	Valve Seat	
7	3710581M1	3	Valve	
8	3710582M1	3	Valve	
9	3710256M1	6	Oil Seal	
10	3702417M1	1	Ball	
11	3710548M3	1	Head Gasket	
12	3710536M1	14	Bolt	
13	3704377M1	2	Stud	

3-IS02-007-A

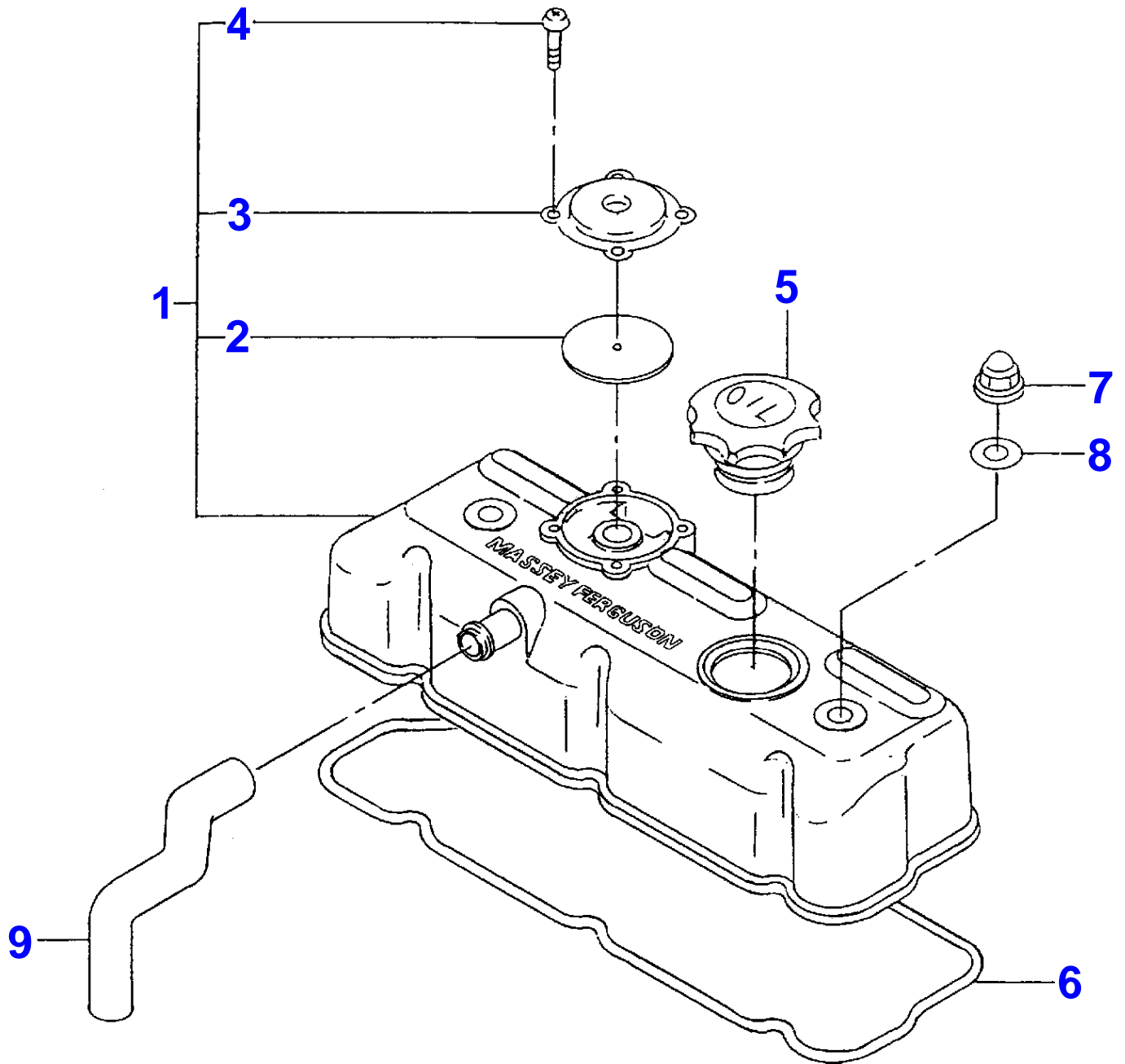

Cylinder Head Cover

Item	Part Number	Qty	Description
1	3710551M91	1	Cover
2	3710554M1	1	Rubber
3	3710561M1	1	Cover
4	3710529M1	4	Screw
5	3710188M1	1	Cap
6	3710553M1	1	Seal
7	3710127M1	2	Nut
8	3706564M1	2	Gasket
9	3710539M1	1	Hose

3-IS03-007-A

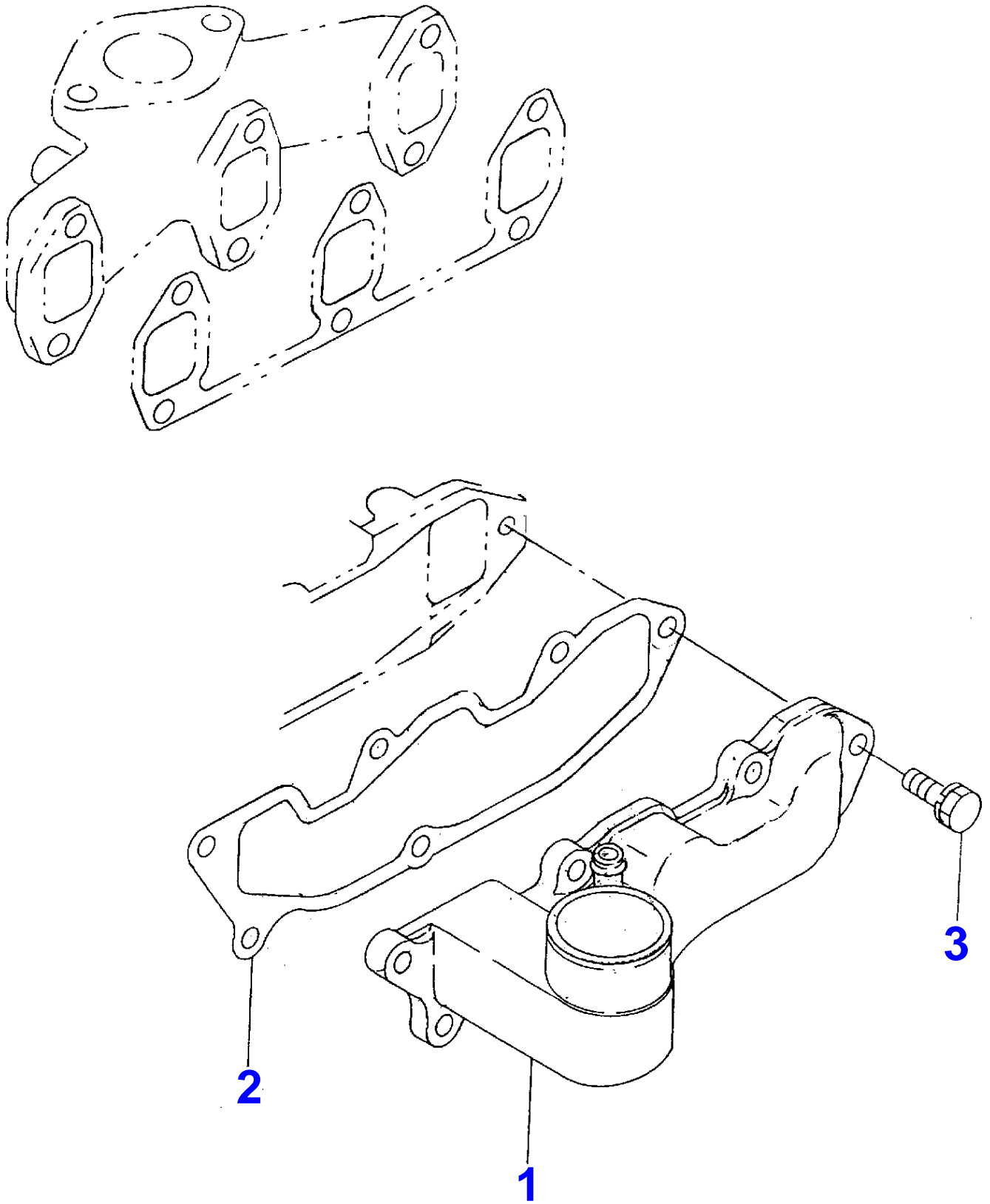

Massey Ferguson

MF 1230 COMPACT TRACTOR - --->| MP5005 - 1637268

1637268

Inlet Manifold

Page010-0020

Item	Part Number	Qty	Description
1	3710647M91	1	Manifold
2	3710649M1	1	Gasket
3	3702273M1	6	Bolt

3-IS04-007-A

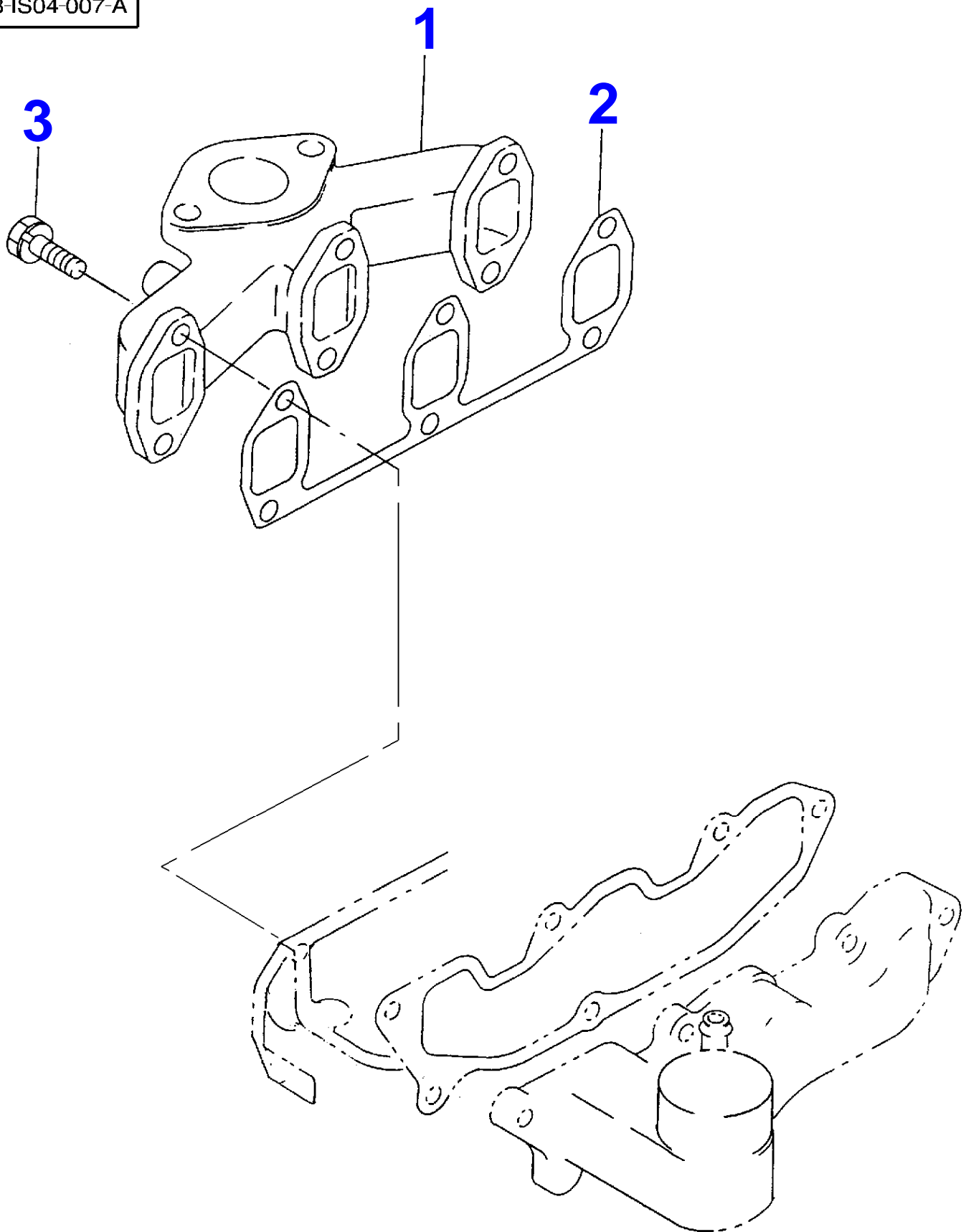

Exhaust Manifold

Item	Part Number	Qty	Description
1	3710651M1	1	Manifold
2	3710652M1	1	Gasket
3	3702273M1	6	Bolt

3-IS05-010-B

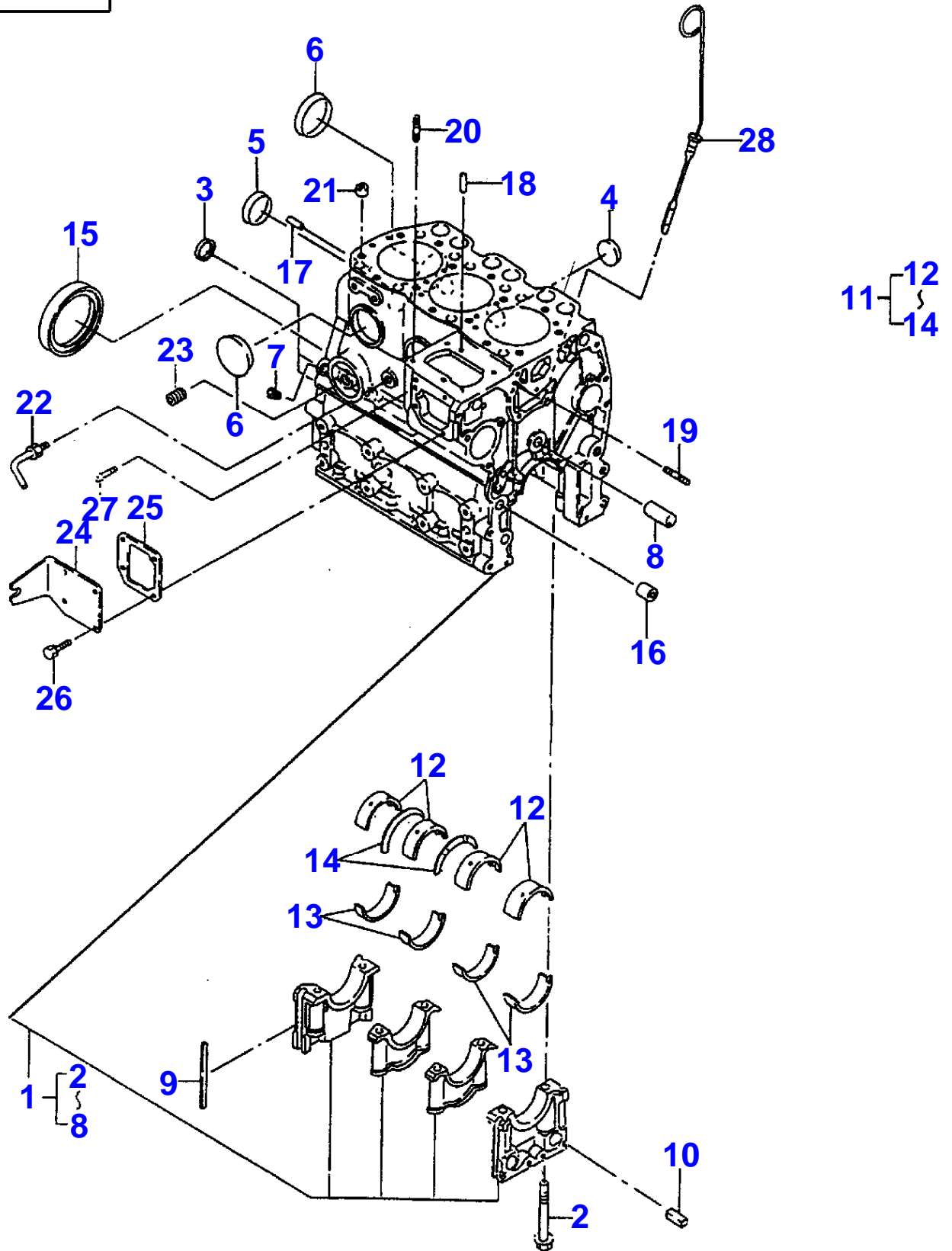

Cylinder Block

Item	Part Number	Qty	Description	Comments
1	3710555M94	1	Cylinder Block	
2	3710537M1	8	Bolt	
3	3704390M1	2	Cup	
4	3710130M1	2	Cap	
5	3704396M1	1	Cup	
6	3710542M1	3	Cup	
7	3704257M1	7	Plug	
8	3710247M2	1	Pin	
9	3710160M1	4	Seal	
10	3710161M1	2	Seal	
11	3710571M91	1	Bearing	STANDARD
	3710574M91	X	Bearing	[A] (-)0,25MM
	3710577M91	X	Bearing	[A] (-)0,50MM
12	3710572M1	4	Bearing	(11) STANDARD
13	3710573M1	4	Bearing	(11) STANDARD
14	3710580M1	2	Bearing Thrust	(11)
15	3710544M1	1	Oil Seal	
16	3710137M2	2	Pin	
17	3710488M1	2	Pin	
18	3710487M1	2	Pin	
19	3706536M1	1	Stud	
20	3704353M1	3	Stud	
21	3704326M1	2	Plug	
22	3706177M1	1	Pipe	
23	3710284M1	1	Connectors	
24	3710560M1	1	Cover	
25	3710163M1	1	Gasket	
26	3710478M1	4	Bolt	
27	3710411M1	1	Pin	
28	3710762M2	1	Gauge	

FOOTNOTE [A] PRE-FINISHED

3-IS05-023-A

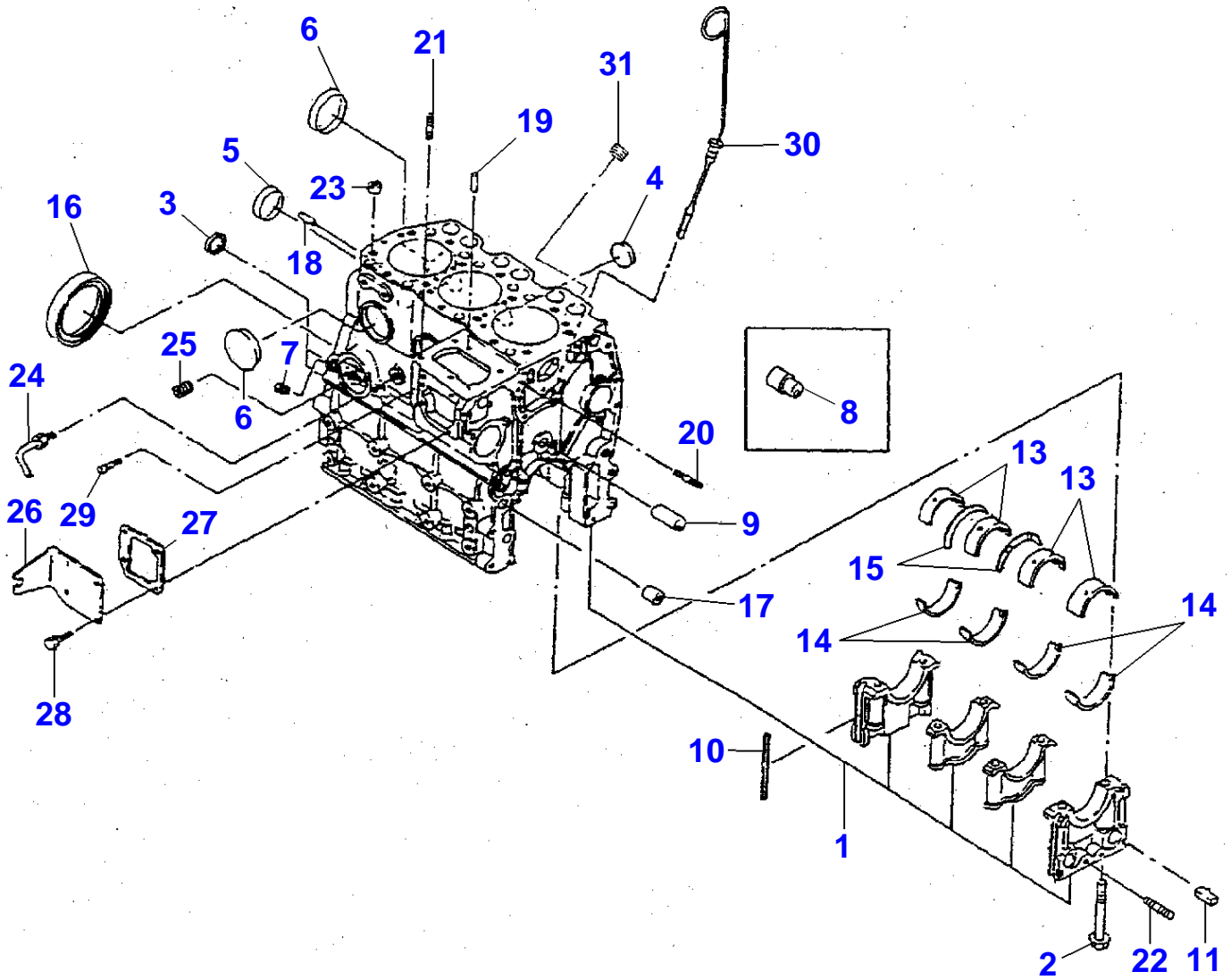

Buy Now



Our support email:

ebooklibonline@outlook.com