

Page Title	Page Number
Engine	010-0005
Alternator	010-0010
Starter	010-0015
Heater - Engine Block	010-0020
Cylinder Block	010-0025
Cylinder Block Equipment	010-0030
Timing Gear Housing	010-0035
Flywheel Housing	010-0040
Crankshaft, Pistons And Connecting Rods	010-0045
Valve Mechanism And Camshaft	010-0050
Cylinder Head	010-0055
Cylinder Head Cover	010-0060
Thermostat	010-0065
Lubricating Oil Sump	010-0070
Lubricating Oil Pump	010-0075
Lubricating Oil Cooler And Filter	010-0080
Drive Shaft - Fan Engine	010-0085
Water Pump	010-0090
Injection Pump	010-0095
Stop Magnet	010-0100
Feed Pump	010-0105
Fuel Pipings	010-0110
Injector	010-0115
Fuel Filter	010-0120
Inlet And Exhaust Manifold	010-0125
Turbocharger - Pipes	010-0130
Cold Starting Device	010-0135
Belt Tensioner	010-0140
Engine Repair Kits - Piston- Cylinder Head With Valves	010-0145
Engine Gaskets Sets	010-0150
Batteries And Cables - Without Battery Cut-Off	010-0155
Cooling System - Air Conditioned Installation	010-0160
Cooling System -Air Conditioned - Sanden Compressor - Up to Serial or Engine Number - H152021	010-0165
Cooling System -Air Conditioned - Sanden Compressor - From Serial or Engine Number - H152022	010-0170
Cooling System - Engine	010-0175
Cooling System - Engine	010-0180
Cab Heating System - Engine Part	010-0185
Fuel System - Fuel Tank And Attachments	010-0190
Fuel System - Fuel Tank And Attachments - Additional Tank	010-0195
Fuel System - Fuel Tank And Attachments - Brackets And Guards - Up To H091014	010-0200
Fuel System - Fuel Tank And Attachments - Brackets And Guards - From H091015	010-0205
Fuel System - Pipes With Thermostart - With Additional Tank - With Fuel Debit	010-0210
Fuel System - Fuel Filter	010-0215
Air Filter - With Thermostart Equipment - 8160 / 200 HP PTO	010-0220
Air Filter - With Thermostart Equipment - 8170	010-0225
Air Filter - Dry - Dual Element - 8160 / 200 HP PTO	010-0230
Air Filter - Dry - Dual Element - 8170	010-0235
Exhaust System - Vertical	010-0240
Throttle Controls	010-0245
Throttle Controls	010-0250
Throttle Controls - Hand	010-0255

MF 8170 TRACTOR - 1637359  
1-AA01-622-C

1-AA01-622-C

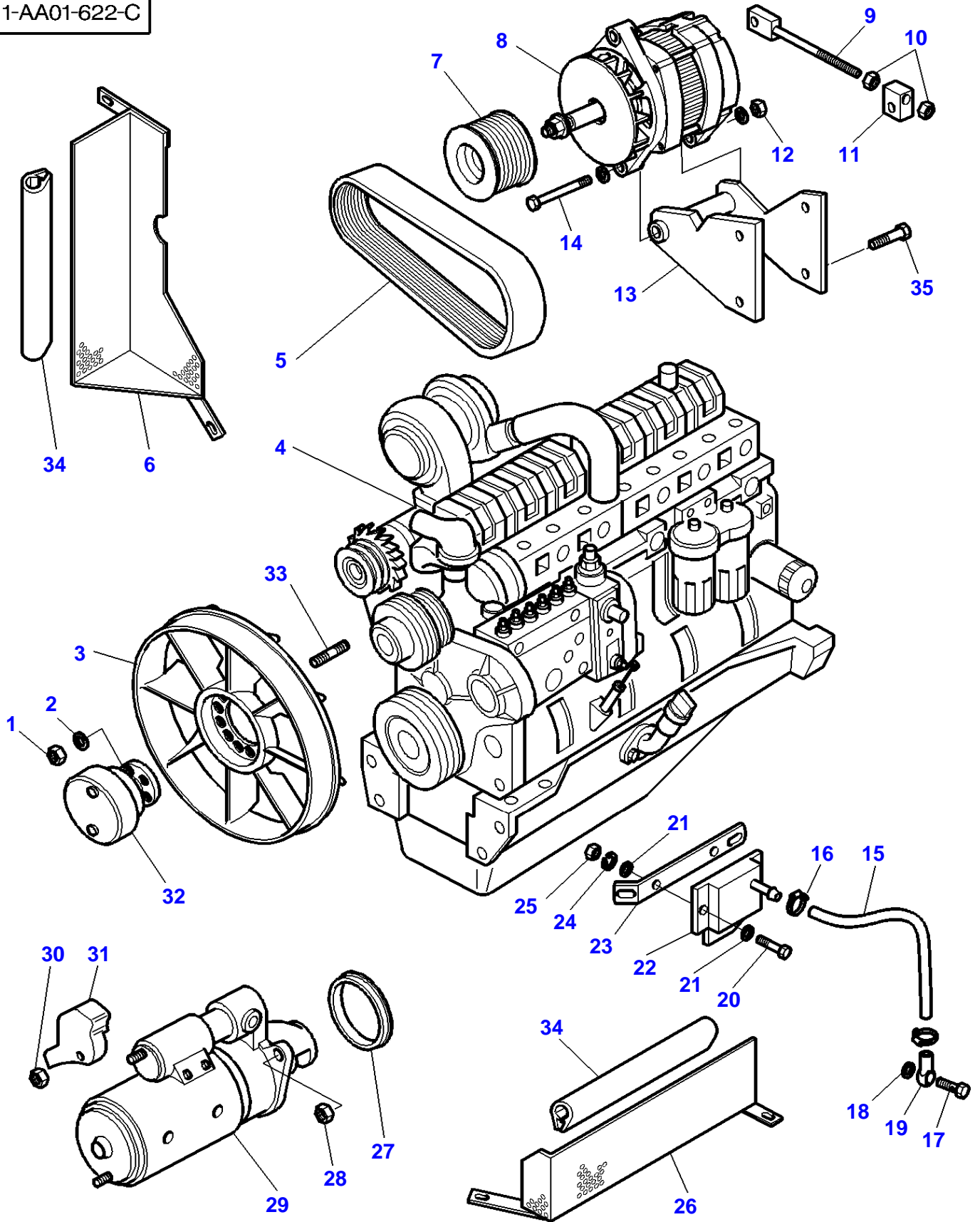

## Engine

Item	Part Number	Qty	Description	Comments
1	1440329X1	6	Locknut	M10
2	390734X1	6	Washer	
3	3777244M1	1	Fan	
4	3777760M91	1	Engine	645 DSIE
5	<b>V836859262</b>	1	Belt	
6	3777415M2	1	Cowl	
7	3777253M1	1	Pulley	
8	<b>71370306</b>	1	Alternator	
9	3779474M1	1	Clevis Pin	
10	3009693X1	2	Nut Metric	
11	3779475M1	1	Clevis Pin	
12	375098X1	1	Nut Unc	
13	3779473M2	1	Support	
14	354679X1	1	Screw	1/2-13 X 153
15	3777331M1	1	Hydr Hose	
16	338612X1	2	Hose Clip	
17	3777549M1	1	Screw	
18	3007188X1	1	Gasket	
19	3777546M1	1	Union	
20	339262X1	2	Bolt Metric	M6X20
21	390971X1	4	Washer	
22	<b>72502305</b>	1	Transmitter	[A]
23	3777330M1	1	Support	
24	339375X1	2	Lock Washer	
25	339030X1	2	Nut Metric	
26	3777416M3	1	Cowl	
27	3778469M1	1	Spacer	
28	3009693X1	3	Nut Metric	
29	3777247M1	1	Startermotor	
30	3611638M1	1	Nut	Up to Serial or Engine Number G166015
31	3611662M1	1	Cover	Up to Serial or Engine Number G166015
	3780936M1	1	Cover	From Serial or Engine Number G166016
32	3777245M2	1	Clutch	
33	391005X1	6	Stud	M10X25
34	3616268M1	1	Gasket	Length 350MM
	3714513M1	1	Gasket	Length 450MM
35	339123X1	2	Hex. Sock. Screw	M8X20
	339291X1	2	Hex. Sock. Screw	M8X55

FOOTNOTE [A] TURBO PRESSURE TRANSDUCER

MF 8170 TRACTOR - 1637359  
1-AC33-003-A

1-AC33-003-A

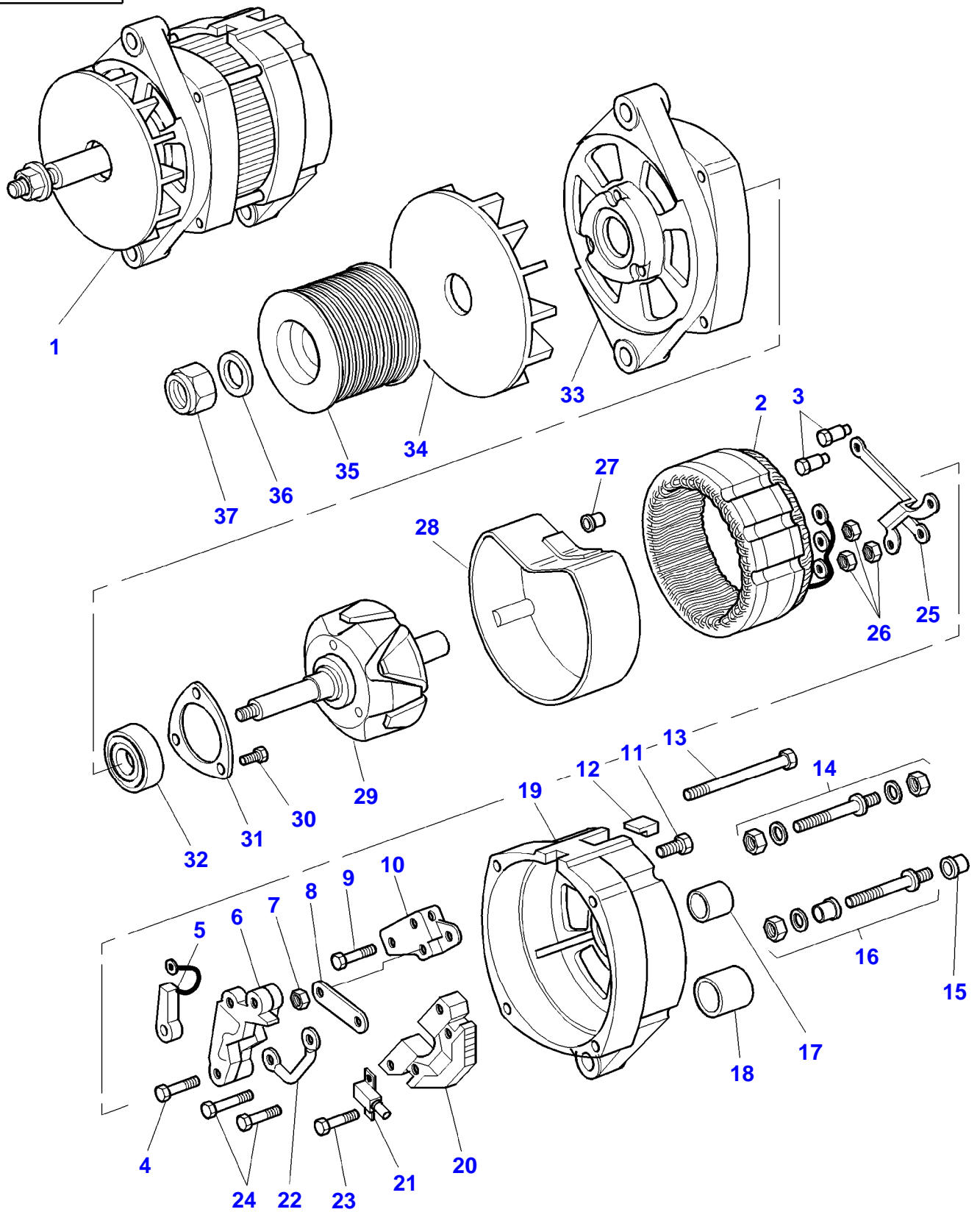

## Alternator

Item	Part Number	Qty	Description	Comments
1	<b>71370306</b>	1	Alternator	
2	71370855	1	Stator	(1)
3	71173328	2	Kit, Screw	(1)
4	71327160	1	Screw	(1)
5	<b>71370867</b>	1	Brush	(1)
6	<b>71370866</b>	1	Holder	(1)
7	355564X1	1	Nut Unc	(1)
8	71370863	1	Connector	(1)
9	70918268	1	Washer	(1)
10	<b>71370860</b>	1	Regulator	(1)
11	71370880	1	Screw	(1)
				8-32X1 3/4
	71370881	1	Screw	(1)
				1/4-20X2
	70921880	1	Washer	(1)
12	71370570	1	Tube	(1)
13	71370879	4	Screw	(1)
				10-24 X 2 1/2
14	71370861	1	Kit, Rod	(1)
15	30-3413926	1	Cap	(1)
16	71370862	1	Kit, Rod	(1)
17	72162794	1	Bearing	(1)
18	30-3413918	1	Bush	(1)
19	71370852	1	Frame	(1)
20	<b>71370858</b>	1	Diode	(1)
21	<b>71370865</b>	1	Capacitor	(1)
22	71370864	1	Connector	(1)
23	71370877	1	Screw	(1)
				8-32 X 1 1/8
24	71370874	3	Screw	(1)
				8-32 X 1
25	<b>71370859</b>	1	Diode	(1)
26	70917385	3	Nut	(1)
				8-32
27	72506418	2	Stub	(1)
28	71370808	1	Cover	(1)
29	71370854	1	Rotor	(1)
30	71370878	3	Screw	(1)
				8 X 1/2
31	71370868	1	Plate	(1)
32	30-3413837	1	Bearing	(1)
33	71370856	1	Frame	(1)
34	71370872	1	Fan	(1)
35	3777253M1	1	Pulley	(1)
36	70918268	1	Washer	(1)
37	70930986	1	Nut	(1)

1-AC37-603-A

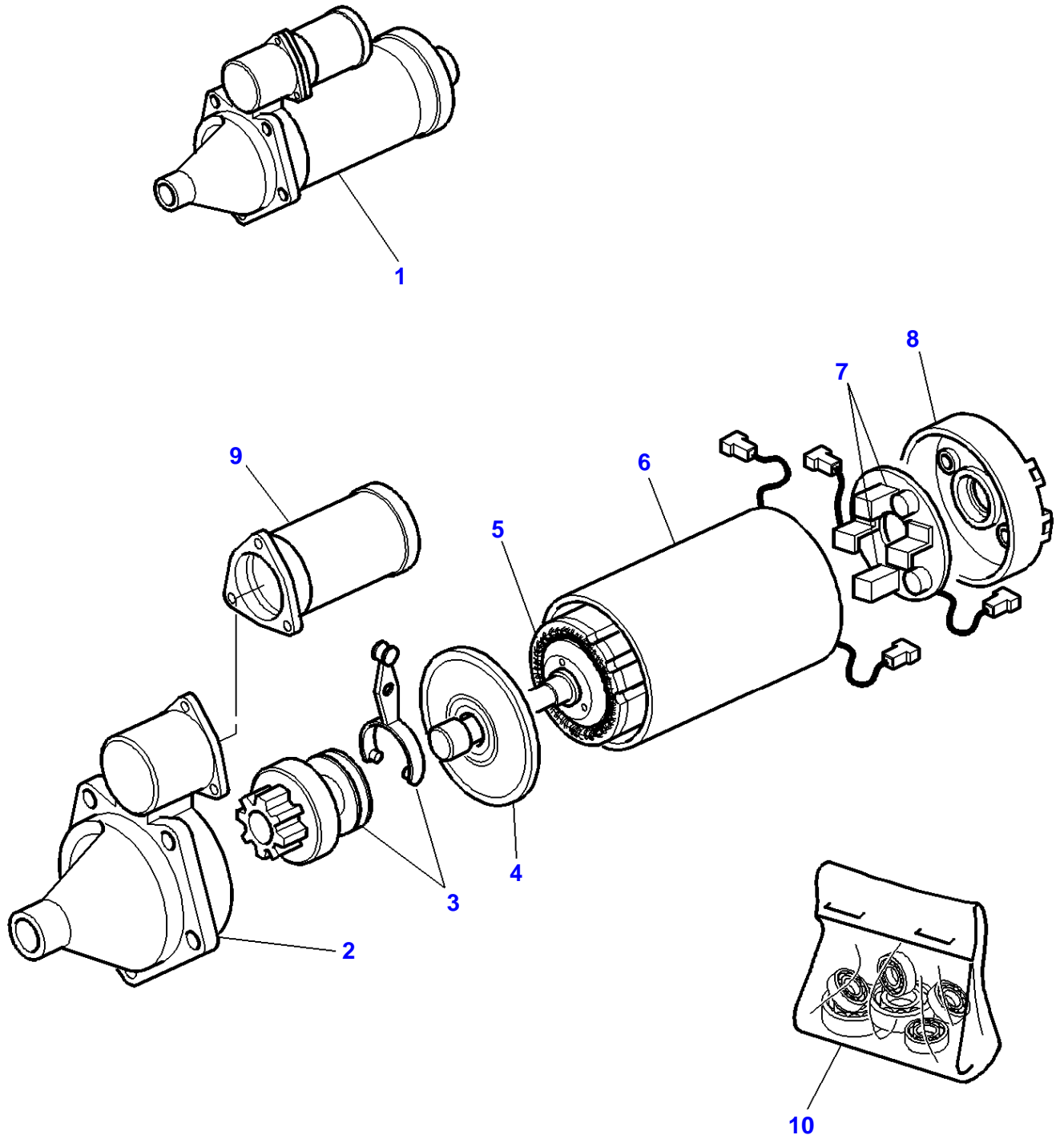

## Starter

Item	Part Number	Qty	Description	Comments
1	3777247M1	1	Startermotor	
2	3903008M91	1	Bracket	(1)
3	3903012M91	1	Drive	(1) Number of teeth/spines 10
4	3903015M1	1	Bearing Plate	(1)
5	3903011M1	1	Armature	(1)
6	3903010M91	1	Coil	(1)
7	3903013M91	1	Kit, Brush	(1)
8	3903009M91	1	Bracket	(1)
9	<b>3902929M1</b>	1	Solenoid	(1)
10	3903014M91	X	Kit, Bush	

1-AC38-602-C

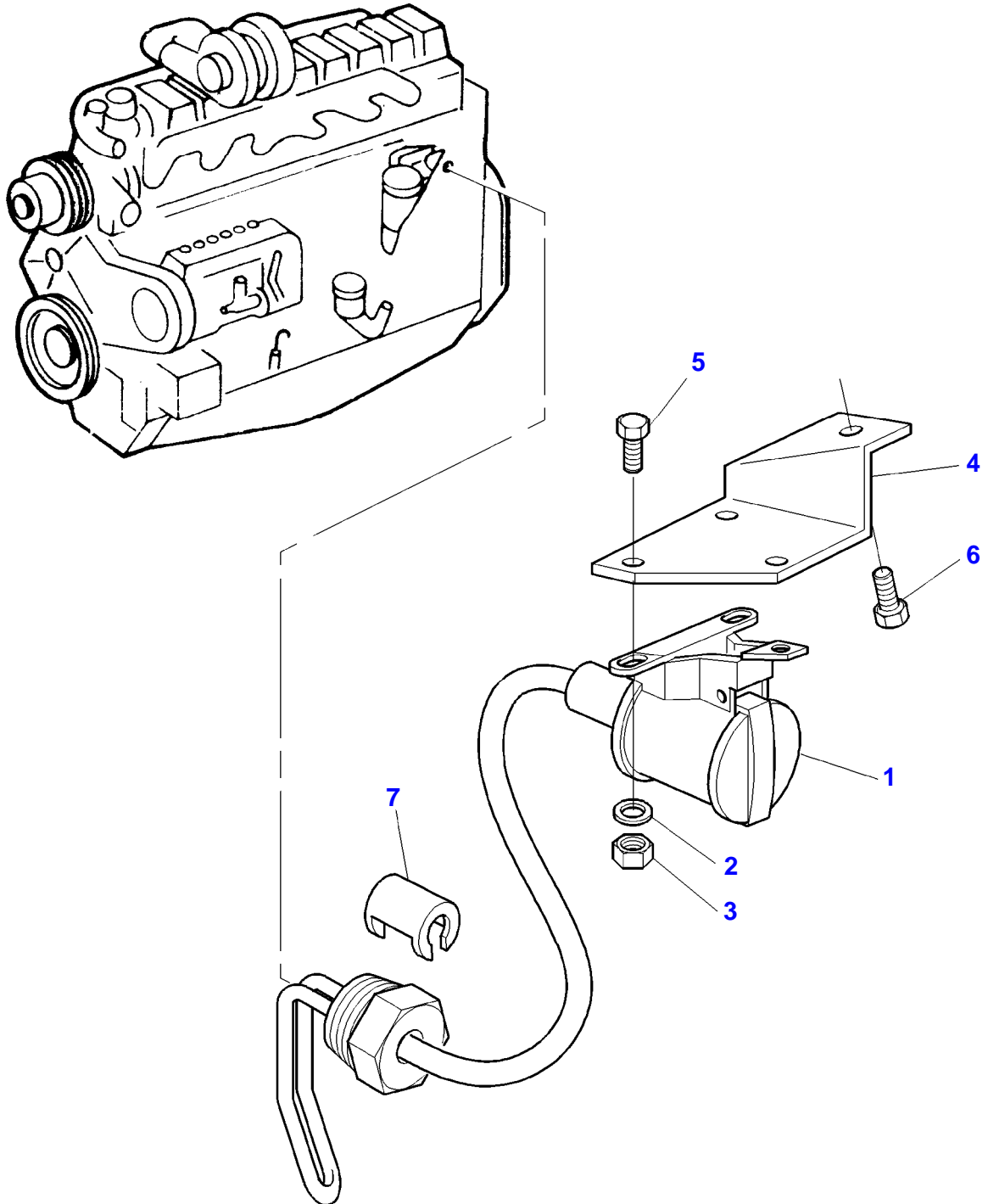



Heater - Engine Block

Item	Part Number	Qty	Description	Comments
1	3615752M2	1	Element	
2	3006154X1	3	Washer	
3	1443615X1	3	Nut Metric	
4	3615753M1	1	Support	
5	3009531X1	3	Screw Metric	M4X12
6	339124X1	1	Hex. Sock. Screw	
7	3611974M1	1	Clip	

MF 8170 TRACTOR - 1637359  
1-LA01-605-A

1-LA01-605-A

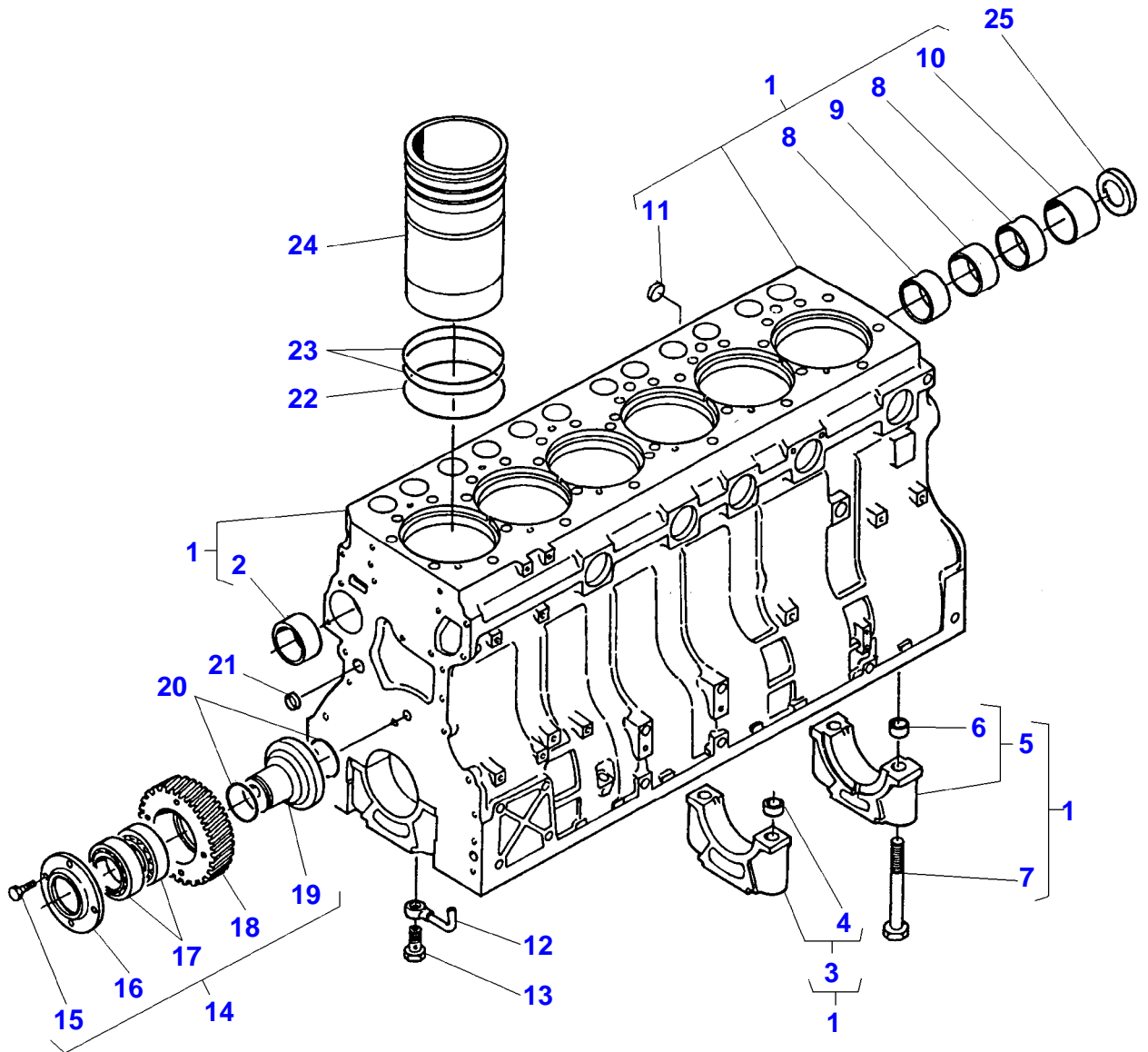

Cylinder Block

Item	Part Number	Qty	Description	Comments
1	V836859155	1	Cylinder Block	
2	V836322610	1	Bush	(1)
3		6	Bearing Carrier	[A] (1)
4	V836214478	2	Bush	(3)
5		1	Bearing Carrier	[A] (1)
6	V836214478	2	Bush	(5)
7	V529903180	14	Screw	(1)
8	V836852460	2	Bush	(1)
9	V836852459	1	Bush	(1)
10	V836852461	1	Bush	(1)
11	V640016018	1	Plug	(1)
12	V836846231	6	Pipe	
13	V836338601	6	Valve	
14	V836859165	1	Gear	
15	V528801380	4	Screw	(14) M8X20
16	V836859164	1	Flange	(14)
17	V610071079	2	Bearing Ball	(14)
18	V836859163	1	Gear	(14)
19	V836859162	1	Shaft	(14)
20	V614603024	2	O Ring	
21	V640016016	4	Plug	
22	V836855447	6	O Ring	
23	V836855446	12	O Ring	
24	V836855445	6	Liner	
25	V836852744	4	Plug	

FOOTNOTE [A] NUMBER TO BE ADVISED

MF 8170 TRACTOR - 1637359  
1-LA02-606-A

1-LA02-606-A

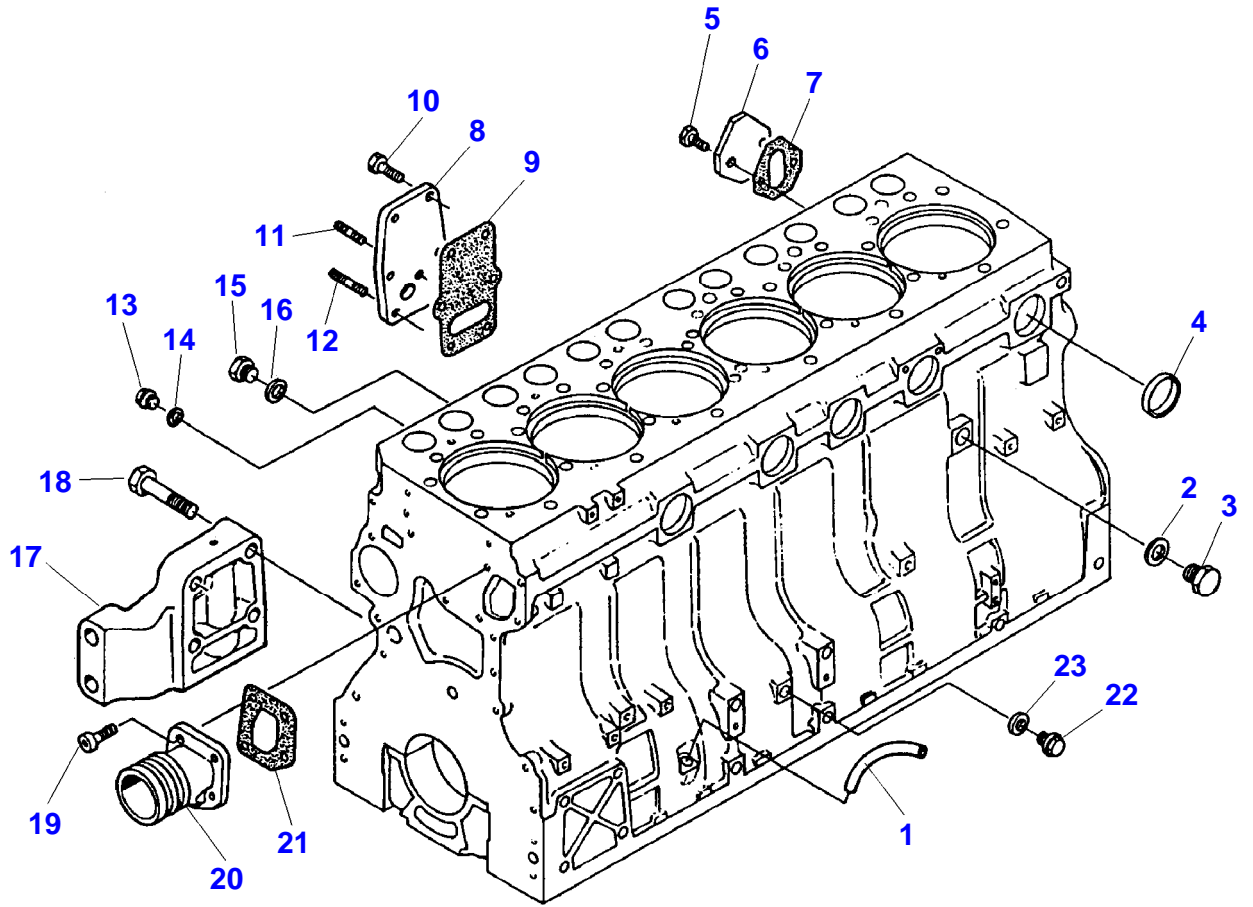

## Cylinder Block Equipment

Item	Part Number	Qty	Description	Comments
1	V836855997	1	Pipe	
2	V615881824	1	Seal	
3	V836019756	1	Plug	
4	V640016040	5	Plug	
5	V528801362	2	Screw	M8X16
6	V836647400	1	Cover	
7	V836647401	1	Gasket	
8	V836855678	1	Cover	
9	V836322852	1	Gasket	
10	V528801380	5	Screw	M8X20
11	V546801360	1	Bolt	M8X16
12	V546801400	1	Bolt	M8X25
13	V640325110	5	Plug	
14	V615571014	5	Seal	
15	V836119079	1	Plug	
16	V615881620	1	Seal	
17	V836338483	1	Support	Right Hand
	V836338482	1	Support	Left Hand
18	V529802280	8	Screw	
19	V581804600	4	Screw	
20	V836855629	1	Sleeve	
21	V836855554	1	Gasket	
22	V640325014	1	Plug	
23	V615881420	1	Gasket	

1-LA03-607-A

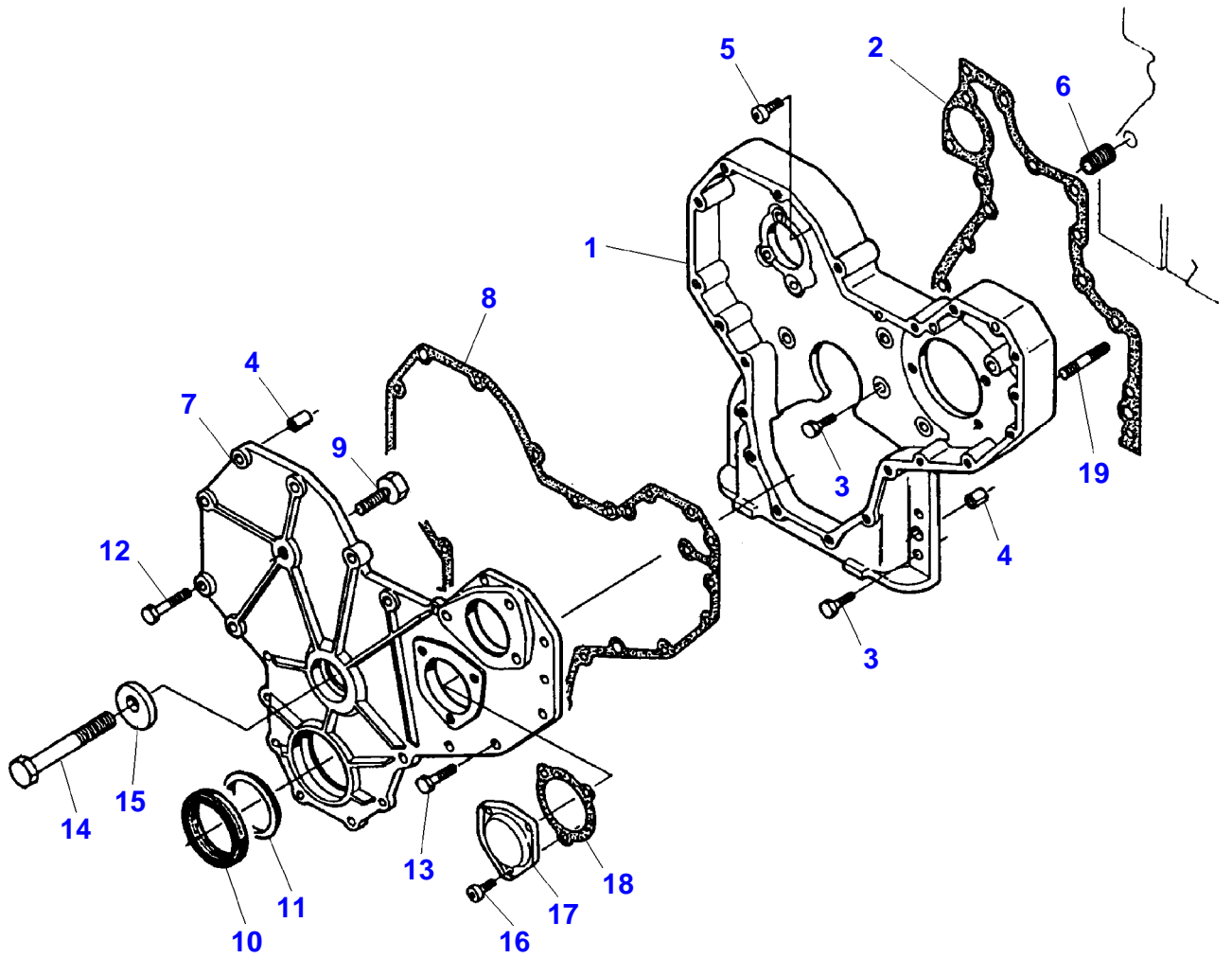

**Buy Now**



Our support email:

[ebooklibonline@outlook.com](mailto:ebooklibonline@outlook.com)