

Page Title	Page Number
Knives And Fingers - Freeflow - 14' - 20'	001-0001
Table Auger Right Hand - Freeflow - 14' - 20'	001-0002
Table Auger Left Hand - Freeflow - 14' - 20'	001-0003
Guarding And Transmissions - Freeflow - 14' - 20'	001-0004
Table Housing And Guarding - Freeflow - 14' - 20'	001-0005
Knives And Fingers - Powerflow - 14' - 20'	001-0006
Table Auger Right Hand - Powerflow - 14' - 20'	001-0007
Tabel Auger Left Hand - Powerflow - 14' - 20'	001-0008
Guarding And Transmissions - Powerflow - 14' - 20'	001-0009
Table Housing And Guarding - Powerflow - 14' - 20'	001-0010
Powerflow Band - Left Hand - 14' - 20'	001-0011
Powerflow Band - Right Hand - 14' - 20'	001-0012
Oilseed Rape Auger	001-0013
Straw Dividers	001-0014
Table Trailer - From No 0000500	001-0015
Table Trailer - UP TO NO. 7374033	001-0016
Lightening Bracket - UP TO NO. 7374033	001-0017
Electric Vertical Knife	001-0018
Decals	001-0019

MF 7250/7252 COMBINE - 1637400
D-ZAZA-005-A

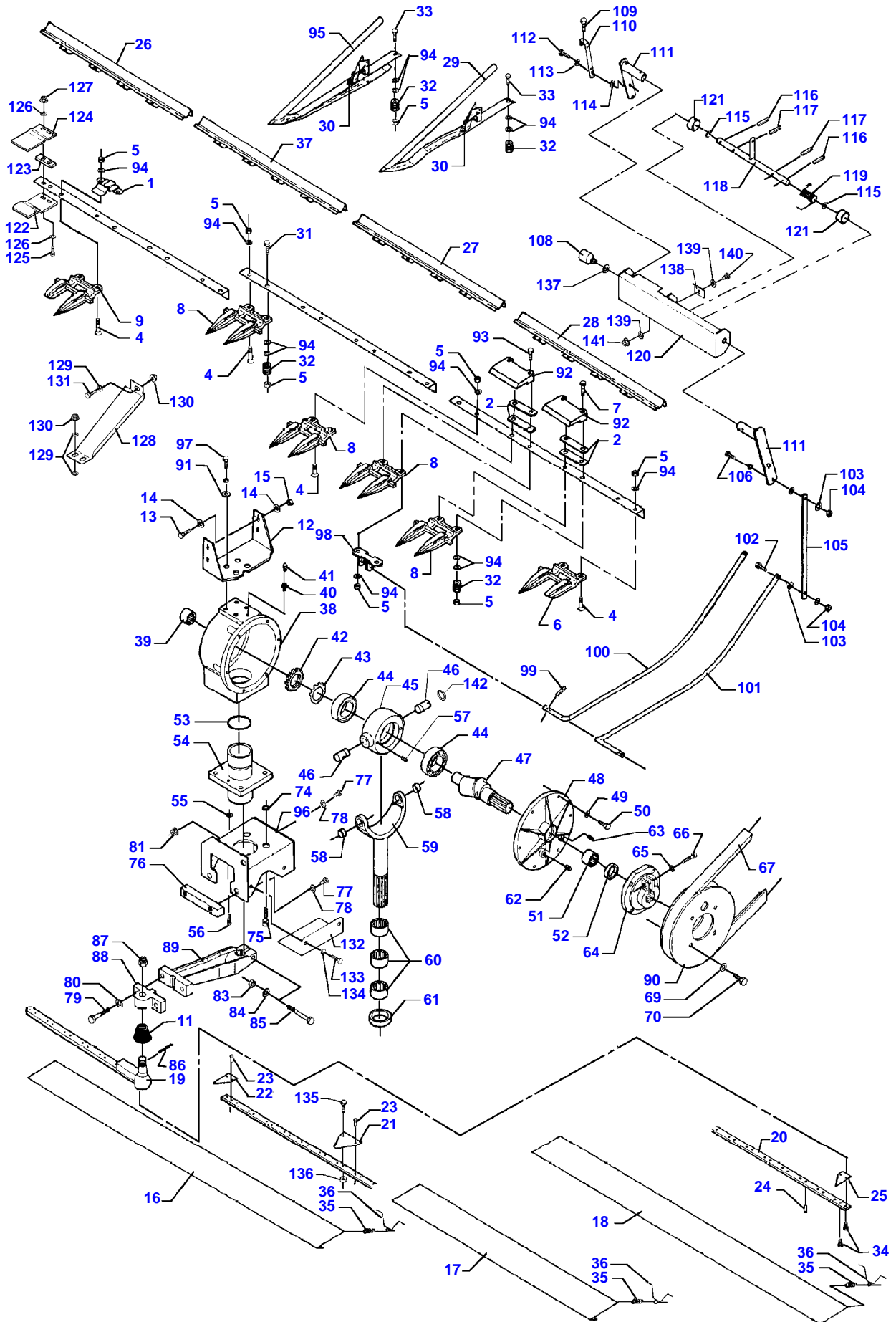

Item	Part Number	Qty	Description	Comments
1	D28283934	13	Clip	14' - 4,34M
	D28283934	15	Clip	16' - 4,95M
	D28283934	17	Clip	18' - 5,56M
	D28283934	19	Clip	20' - 6,16M
2	D28230292	4	Shim	
4	D40551500	X	Bolt	
5	D41010800	X	Nut	
6	D44104700	1	Finger	Left Hand
7	D40067600	X	Screw	
8	D44104500	27	Finger	14' - 4,34M
	D44104500	31	Finger	16' - 4,95M
	D44104500	35	Finger	18' - 5,56M
	D44104500	39	Finger	20' - 6,16M
9	D44104600	1	Finger	Right Hand
11	D44120500	1	Cap	
12	D28283104	1	Support	
13	D40405100	2	Hex. Sock. Screw	
14	D20400414	4	Washer	
15	D41087500	2	Locknut	
16	D28230842	2	Guard	18' - 5,56M
	D28230844	1	Guard	20' - 6,16M
	D28230845	1	Guard	16' - 4,95M
	D28230842	1	Guard	14' - 4,34M
17	D28230843	1	Guard	18' - 5,56M
18	D28230844	1	Guard	16' - 4,95M
	D28230845	1	Guard	20' - 6,16M
19	D28283009	2	Blade	18' - 5,56M
	D28283010	2	Blade	20' - 6,16M
	D28283307	2	Blade	14' - 4,34M
	D28283308	2	Blade	16' - 4,95M
	D28283011	2	Knife Head	
20	D28281490	2	Knife Back	16' - 4,95M
	D28281491	2	Knife Back	18' - 5,56M
	D28281492	2	Knife Back	20' - 6,16M
	D28281493	2	Knife Back	22' - 6,77M
21	D44103700	X	Section	OPTIONAL
22	D44103800	2	Half Section	
23	D41306100	X	Rivet	OPTIONAL
24	D41306200	X	Rivet	OPTIONAL
25	D44104000	2	Half Section	Left Hand
26	D18283701	1	Stone Trap	Right Hand
27	D18283705	1	Stone Trap	18' - 5,56M
	D18283706	1	Stone Trap	20' - 6,16M
28	D18283702	1	Stone Trap	Left Hand
29	D49040200	X	Ear Lifter	
30	D49040400	X	Spring	
31	D40426000	X	Hex. Sock. Screw	
32	D49040600	X	Roller	
33	D40426000	X	Hex. Sock. Screw	
34	D40402400	2	Hex. Sock. Screw	
35	D26500317	2	Spring	(1)
	D26500317	2	Spring	(16)
	D26500317	2	Spring	(17)
	D26500317	2	Spring	(18)
36	D28230841	2	Spring	(1)
	D28230841	2	Spring	(16)
	D28230841	2	Spring	(17)
	D28230841	2	Spring	(18)
37	D18283703	1	Stone Trap	14' - 4,34M
	D18283704	1	Stone Trap	16' - 4,95M
38	D28281324	1	Wobble Drive	[A] Cpl.
	D44127800	1	Box	[A] (38)
	D28281324	1	Wobble Drive	[B] (38) Cpl.
	D44126500	1	Box	[B] (38)
39	D44128800	1	Bearing Needle	(38)
40	D44129400	1	Connector	(38)

Item	Part Number	Qty	Description	Comments
41	D46116500	1	Valve	(38)
42	D44129100	1	Nut	(38)
43	D44129200	1	Washer	(38)
44	D41668400	2	Roller Bearing	(38)
45	D44127900	1	Housing	[A] (38)
45	D44126400	1	Housing	[B] (38)
46	D44128000	2	Journal	[A] (38)
46	D44125900	1	Journal	[B] (38)
47	D44129300	1	Shaft	(38)
48	D44128200	1	Cover	[A] (38)
48	D44126300	1	Cover	[B] (38)
49	D41100700	6	Spring Washer	(38)
50	D40404900	6	Hex. Sock. Screw	(38)
51	D41669700	1	Bearing Needle	(38)
52	D45412000	1	Gasket	(38)
53	D45481500	1	O Ring	(38)
54	D44128300	1	Bearing Carrier	[A] (38)
54	D44126200	1	Bearing Carrier	[B] (38)
55	D41100700	2	Spring Washer	(38)
56	D40697200	2	Screw	[A] (38)
56	D40697700	2	Screw	[B] (38)
57	D40639600	2	Pin	[A] (38)
58	D44128400	2	Bush	[A] (38)
58	D44126100	2	Bush	[B] (38)
59	D44128500	1	Yoke	[A] (38)
59	D44126000	1	Yoke	[B] (38)
60	D41669800	3	Bearing Needle	(38)
61	D45409500	1	Gasket	(38)
62	D44128600	1	Plug	(38)
63	D45236200	1	Plug	(38)
64	D44127100	1	Hub	(38)
65	D41100900	1	Spring Washer	(38)
66	D40694000	1	Screw	(38)
67	D41985600	1	Belt	
69	D20400426	4	Washer	
70	D40410900	4	Hex. Sock. Screw	
74	D20400522	4	Spacer	
75	D40465400	4	Screw	
76	D28283103	1	Clamp	
77	D40416500	5	Hex. Sock. Screw	
78	D20400461	5	Washer	
79	D40698400	2	Screw	
80	D20400438	2	Washer	
81	D41087900	2	Locknut	
83	D41087700	1	Locknut	
84	D20400428	1	Washer	
85	D40429400	1	Hex. Sock. Screw	
86	D41409100	1	Split Pin	
87	D41054300	1	Nut	
88	D44126900	1	Flange	
89	D44127000	1	Swivel Arm	
90	D44127200	1	Pulley	
91	D28280986	4	Washer	
92	D28260362	X	Clip	
93	D40067200	X	Screw	
94	D20400419	X	Washer	
95	D49040300	X	Ear Lifter	

Item	Part Number	Qty	Description	Comments
96	D28283109	1	Support	
97	D40405100	4	Hex. Sock. Screw	
98	D28284356	4	Fitting	ACC AUTO-LEVEL
99	D42611800	8	Pin	ACC AUTO-LEVEL
100	D28284257	2	Sensor	ACC AUTO-LEVEL
101	D28284258	2	Sensor	ACC AUTO-LEVEL
102	D40405300	4	Screw	ACC AUTO-LEVEL
103	D20400506	20	Washer	ACC AUTO-LEVEL
104	D41087500	8	Locknut	ACC AUTO-LEVEL
105	D28284223	4	Link	ACC AUTO-LEVEL
106	D40423600	4	Hex. Sock. Screw	ACC AUTO-LEVEL
108	D28780523	2	Potentiometer	ACC AUTO-LEVEL
109	D40464900	2	Screw	ACC AUTO-LEVEL
110	D28780845	2	Rod	ACC AUTO-LEVEL
111	D28284225	4	Lever	AUTO-LEVEL 18' - 22' 5,56M - 6,77M
111	D28284234	4	Lever	ACC AUTO-LEVEL
112	D40402700	2	Hex. Sock. Screw	ACC AUTO-LEVEL
113	D20400404	2	Washer	ACC AUTO-LEVEL
114	D41013400	2	Nut	ACC AUTO-LEVEL
115	D28200551	4	Washer	ACC AUTO-LEVEL
116	D42611900	8	Pin	ACC AUTO-LEVEL
117	D42612300	4	Pin	ACC AUTO-LEVEL
118	D28284232	2	Shaft	ACC AUTO-LEVEL
119	D28284389	2	Spring	ACC AUTO-LEVEL
120	D28284222	2	Support	AUTO-LEVEL 16' - 4,95M
120	D28284229	2	Support	AUTO-LEVEL 18' - 22' 5,56M - 6,77M
121	D28284456	4	Bush	ACC AUTO-LEVEL
122	D28281576	1	Plate	
123	D28281575	1	Shim	
124	D28281574	1	Plate	
125	D40423700	2	Hex. Sock. Screw	
126	D20400506	2	Washer	
127	D41087500	2	Locknut	
128	D18281572	1	Guard	
129	D20400506	3	Washer	
130	D41017500	3	Locknut	
131	D40405000	1	Hex. Sock. Screw	
132	D28281706	1	Guard	
133	D40404700	2	Hex. Sock. Screw	
134	D20400506	2	Washer	
135	D40402400	X	Hex. Sock. Screw	Alternative D41306100
136	1441462X1	X	Locknut	Alternative D41306100 Replace and repair. Old not interchangeable with new D41087400
137	D20400441	1	Washer	
138	D28284268	2	Stop	
139	D20400416	4	Washer	
140	D40404900	2	Hex. Sock. Screw	
141	D41087500	2	Locknut	
142	D45483000	1	O Ring	[B]

FOOTNOTE [A] USED ONLY IN KNIFE DRIVES WITH 6 HOLES IN BEARING HOUSING BOTTOM

FOOTNOTE [B] USED ONLY IN KNIFE DRIVES WITH 8HOLES IN BEARING HOUSING BOTTOM AND BULGES SIDES

MF 7250/7252 COMBINE - 1637400
D-ZAZB-005-A

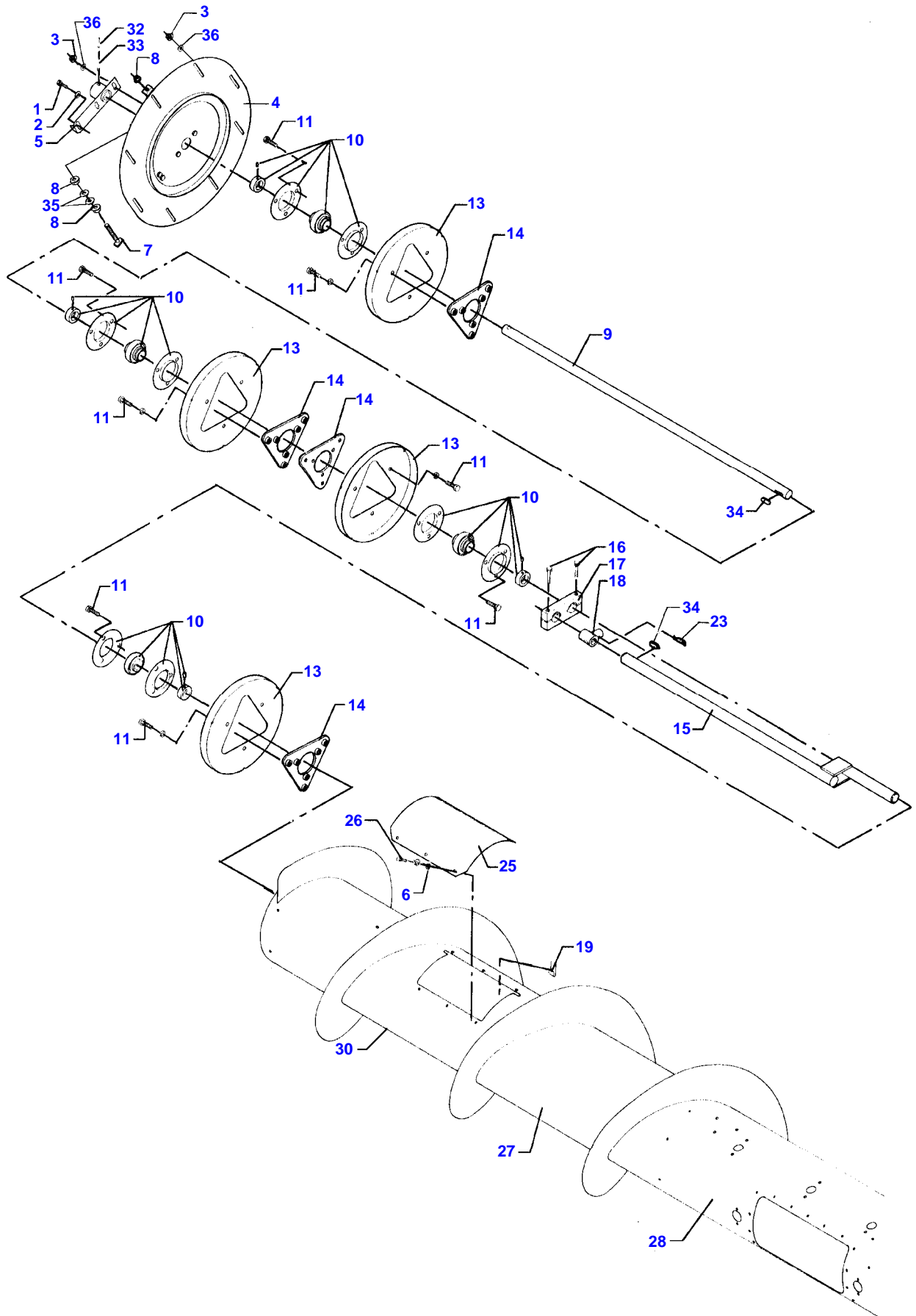

Item	Part Number	Qty	Description	Comments
1	D40404700	1	Hex. Sock. Screw	
2	D20400506	1	Washer	
3	D41017500	10	Locknut	
4	D18280040	1	Plate	
5	D28283029	1	Adjuster	
6	D20400470	6	Washer	
7	D28211023	1	Bolt	
8	D41087600	2	Locknut	
9	D28283036	1	Shaft	18' - 5,56M
	D28283037	1	Shaft	20' - 6,16M
				Up to Serial or Engine Number 940147
	D28284655	1	Shaft	20' 6,16M
				From Serial or Engine Number 940148
	D28283767	1	Shaft	14' - 4,34M
	D28283768	1	Shaft	16' - 4,95M
10	D41707800	4	Bearing	
11	D40407900	24	Hex. Sock. Screw	
13	D28280014	4	Plate	
14	D28283847	4	Bearing Plate	
15	D28283016	1	Crankshaft	
16	D40426100	2	Hex. Sock. Screw	
17	D28283039	1	Arm	
18	D28251831	15	Bearing Carrier	
19	D43428200	6	Nut	
23	D28283853	15	Hair Pin	
25	D18283070	1	Cover	
26	D40402600	6	Hex. Sock. Screw	
27	D18283125	1	Table Auger	20' - 6,16M
				Up to Serial or Engine Number 940147
	D18283134	1	Table Auger	18' - 5,56M
				Up to Serial or Engine Number 940147
	D18283789	1	Table Auger	14' - 4,34M
				Up to Serial or Engine Number 940147
	D18283790	1	Table Auger	16' - 4,95M
				Up to Serial or Engine Number 940147
	D18285988	1	Table Auger	14' - 4,34M
				From Serial or Engine Number 940148
	D18285989	1	Table Auger	16' - 4,95M
				From Serial or Engine Number 940148
	D18285990	1	Table Auger	18' - 5,56M
				From Serial or Engine Number 940148
	D18285991	1	Table Auger	20' - 6,16M
				From Serial or Engine Number 940148
28	D28283012	1	Body	
30	D28283032	1	Body	Right Hand
				18' - 5,56M
	D28283034	1	Body	Right Hand
				20' - 6,16M
	D28283792	1	Body	Right Hand
				14' - 4,34M
	D28283795	1	Body	Right Hand
				16' - 4,95M
32	D42616400	1	Pin	
33	D42625300	1	Pin	
34	D43104700	2	Key	
35	D20400471	2	Washer	
36	D20400414	X	Washer	

MF 7250/7252 COMBINE - 1637400
D-ZAZC-005-A

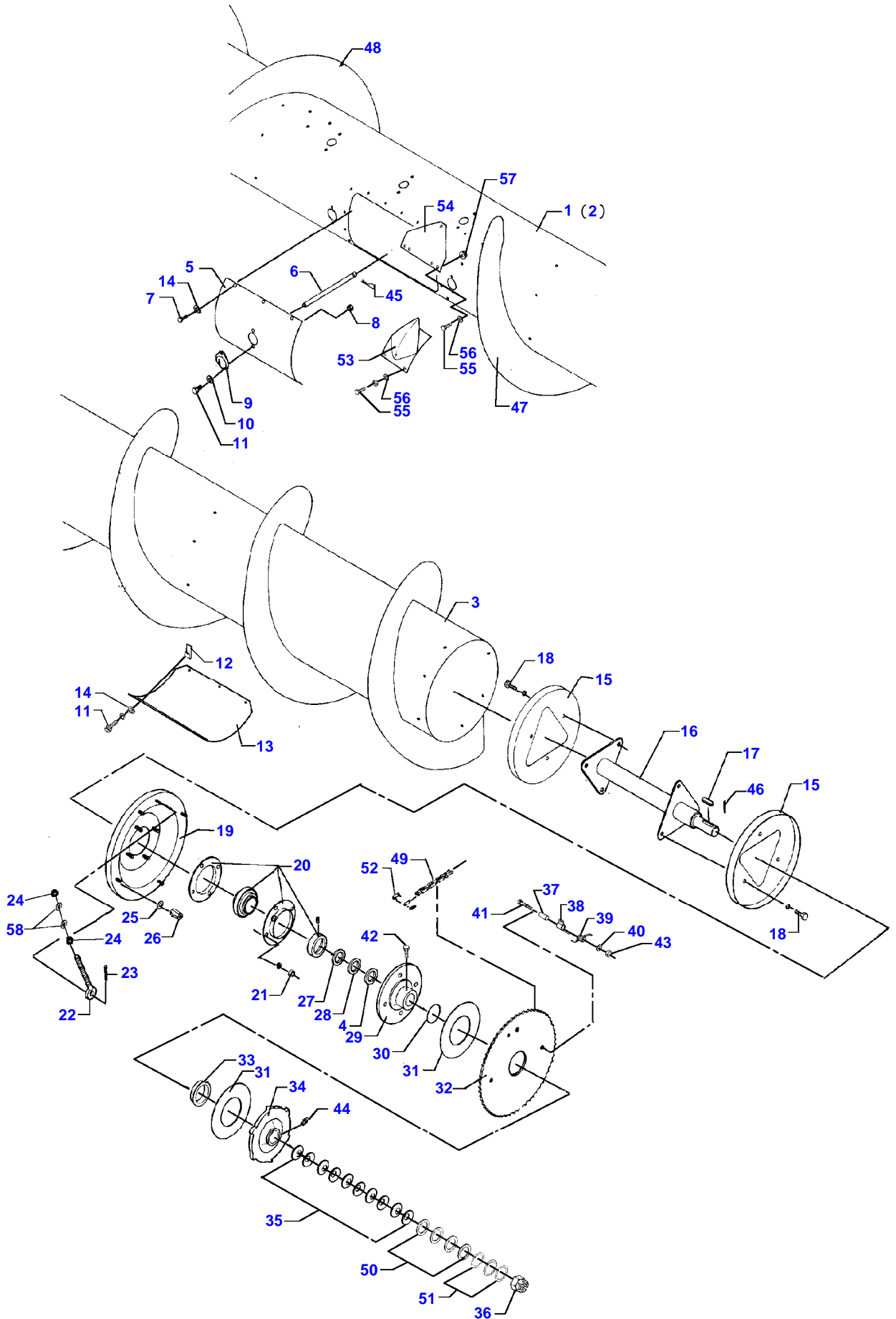

Item	Part Number	Qty	Description	Comments
1	D18283125	1	Table Auger	20' - 6,16M Up to Serial or Engine Number 940147
	D18283134	1	Table Auger	18' - 5,56M Up to Serial or Engine Number 940147
	D18283789	1	Table Auger	14' - 4,34M Up to Serial or Engine Number 940147
	D18283790	1	Table Auger	16' - 4,95M Up to Serial or Engine Number 940147
	D18285988	1	Table Auger	14' - 4,34M From Serial or Engine Number 940148
	D18285989	1	Table Auger	16' - 4,95M From Serial or Engine Number 940148
	D18285990	1	Table Auger	18' - 5,56M From Serial or Engine Number 940148
	D18285991	1	Table Auger	20' - 6,16M From Serial or Engine Number 940148
2	D28283012	1	Body	
3	D28283031	1	Body	Left Hand 20' - 6,16M
	D28283033	1	Body	Left Hand 18' - 5,56M
	D28283793	1	Body	Left Hand 14' - 4,34M
	D28283794	1	Body	Left Hand 16' - 4,95M
4	D41653500	X	Washer	OPTIONAL
5	D18283078	1	Cover	
6	D28283815	15	Finger	
7	D40402400	X	Hex. Sock. Screw	
8	1441462X1	X	Locknut	Replace and repair. Old not interchangeable with new D41087400
9	D28283060	15	Bush	
10	D20400404	X	Washer	
11	D40402600	X	Hex. Sock. Screw	
12	D43428200	6	Nut	
13	D18283070	1	Cover	
14	D20400470	6	Washer	
15	D28280014	2	Plate	
16	D28283007	1	Drive Shaft	
17	D43106800	1	Key	
18	D40407600	6	Hex. Sock. Screw	
19	D18283053	1	Plate	
20	D41716500	1	Bearing	
21	D41010900	4	Nut	
22	D28281387	1	Screw	
23	D41408900	1	Split Pin	
24	D41010800	2	Nut	
25	D20400415	4	Washer	
26	D28280729	4	Nut	
27	D41653500	X	Washer	
28	D41653500	2	Washer	
29	D28283004	1	Washer	
30	D45481600	1	O Ring	
31	D45904300	2	Friction Disc	
32	D28283008	1	Sprocket	
33	D28283000	1	Insert	
34	D28283003	1	Clutch Disc	
35	D41112400	10	Washer	
36	D41054100	1	Castle Nut	
37	D28281431	1	Spacer	
38	D28281432	1	Support	
39	D28283006	1	Spring	
40	D20400507	1	Spacer	
41	D40426100	1	Hex. Sock. Screw	
42	D40405000	1	Hex. Sock. Screw	
43	D41087600	1	Locknut	
44	D43001500	1	Greaser	
45	D28283853	15	Hair Pin	
46	D41408800	1	Split Pin	
47	D28280005	1	Auger	20' - 6,16M
	D28280051	1	Auger	18' - 5,56M
	D28280052	1	Auger	16' - 4,95M

Massey Ferguson**MF 7250/7252 COMBINE - 1637400**

1637400

Table Auger Left Hand - Freeflow - 14' - 20'

Page001-0003

Item	Part Number	Qty	Description	Comments
47	D28280988	1	Auger	14' - 4,34M
48	D28280006	1	Auger	20' - 6,16M
48	D28280053	1	Auger	18' - 5,56M
48	D28280054	1	Auger	16' - 4,95M
48	D28280989	1	Auger	14' - 4,34M
49	D42329300	1	Chain	
50	D20400520	4	Spacer	
51	D20400522	3	Spacer	
52	D42365100	1	Link	
53	D28283294	4	Spike	
54	D28281694	4	Threaded Part	
55	D40404900	20	Hex. Sock. Screw	
56	D20400506	20	Washer	
57	D41087500	12	Locknut	
58	D20400471	2	Washer	

MF 7250/7252 COMBINE - 1637400
D-ZAZD-005-B

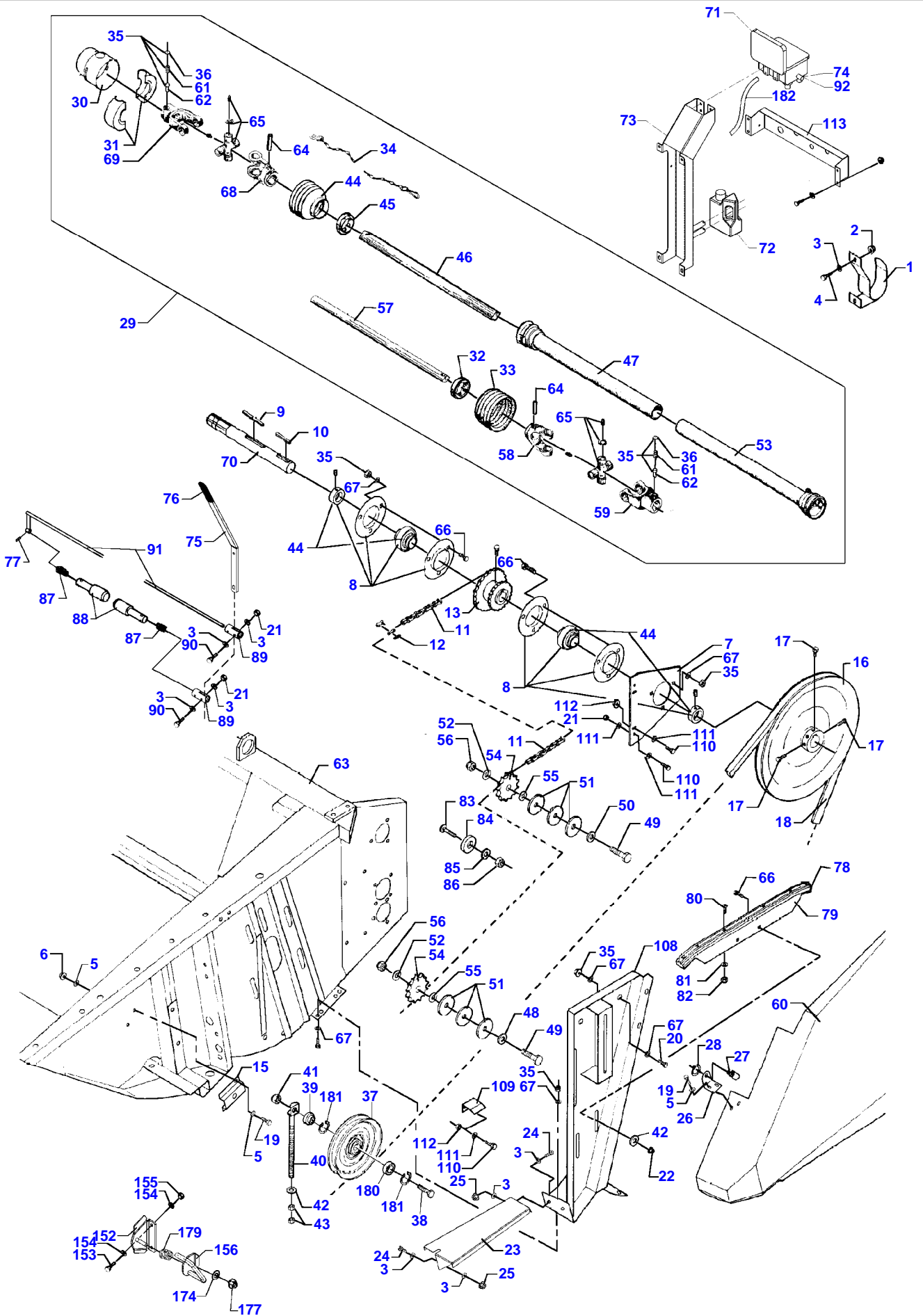

Item	Part Number	Qty	Description	Comments
1	D18281345	1	Stirrup	
2	D41013500	X	Nut	
3	D20400506	X	Washer	
4	D40404700	X	Hex. Sock. Screw	
5	D20400470	X	Washer	
6	1441462X1	X	Locknut	Replace and repair. Old not interchangeable with new D41087400
7	D18283099	1	Bearing Carrier	
8	D41707800	2	Bearing	
9	D43114900	1	Key	
10	D43105000	1	Key	
11	D42329300	1	Chain	
12	D42365100	1	Link	
13	D28280225	1	Sprocket	
15	D28281578	1	Retainer	
16	D28285423	1	Pulley	
17	D40697900	3	Screw	
18	D41985600	1	Belt	
19	D40402600	X	Hex. Sock. Screw	
20	D40407700	4	Hex. Sock. Screw	
21	D41087500	X	Locknut	
22	D41087600	X	Locknut	
23	D28281570	1	Plate	
24	D40405000	3	Hex. Sock. Screw	
25	D41087500	3	Locknut	
26	D28281577	1	Angle.	
27	D43427500	1	Pin	
28	D42555500	1	Circlip	
29	D45608900	1	Shaft	14' - 4,34M
	D45609000	1	Shaft	16' - 4,95M
	D45609100	1	Shaft	18' - 20' 5,56M - 6,16M
30	D45632900	1	Bush	
31	D45633000	1	Ring	
32	D45630700	1	Ring	
33	D45630500	1	Guard	
34	D45681800	2	Chain	
35	D45632400	2	Tube	
36	D45645700	2	Washer	
37	D28760574	1	Pulley	Valid from machine/table no,can be used in new as well as in older machines 58241
38	D28760156	1	Screw	
39	D28760155	1	Bush	
40	D28260181	1	Bolt	
41	D41087900	X	Locknut	
42	D20400416	X	Washer	
43	D41010800	X	Nut	
44	D45630400	1	Guard	
45	D45630600	1	Ring	
46	D45631100	1	Tube	18' - 20' 5,56M - 6,16M
	D45632800	1	Tube	16' - 4,95M
47	D45631900	1	Tube	18' - 20' 5,56M - 6,16M
	D45632600	1	Tube	16' - 4,95M
48	D28181284	1	Washer	
49	D40433600	2	Hex. Sock. Screw	
50	D20400463	1	Washer	
51	D20400460	6	Washer	
52	D20400459	2	Washer	
53	D45632100	1	Tube	14' - 4,34M
	D45632300	1	Tube	18' - 20' 5,56M - 6,16M
	D45632500	1	Tube	16' - 4,95M
54	D41716800	2	Tightener	
55	D20400516	X	Spacer	OPTIONAL
56	D41087900	2	Locknut	

Item	Part Number	Qty	Description	Comments
57	D45631500	1	Tube	18' - 20' 5,56M - 6,16M
57	D45632700	1	Tube	16' - 4,95M
58	D45630100	1	Yoke	
59	D45633200	1	Yoke	
60	D18281583	1	Guard	
61	D45667300	2	Spring	
62	D45665300	2	Pin	
63	D18285501	1	Table Housing	14' - 4,34M
63	D18285502	1	Table Housing	16' - 4,95M
63	D18285503	1	Table Housing	18' - 5,56M
63	D18285504	1	Table	20' - 6,16M
64	D42619100	2	Pin	
65	D45630300	2	Hub	
66	D40066800	8	Screw Special	
67	D20400419	X	Washer	
68	D45630200	1	Yoke	
69	D45633100	1	Yoke	
70	D28284404	1	Shaft	
71	D28785641	1	Clutch	[A]
72	D45148900	1	Container	[A]
73	D28285296	1	Bracket	[A]
74	D45140037	2	Screw	[A]
75	D28285536	1	Lever	
76	D43484900	1	Lever	
77	D42612200	X	Pin	
78	D28280787	1	Rail	
79	D28281365	1	Crossmember	
80	D40609300	6	Screw	
81	D20400466	6	Washer	
82	D41087200	6	Locknut	
83	D40073100	1	Screw	
84	D28280981	1	Spacer	
85	D20400459	1	Washer	
86	D41087900	1	Locknut	
87	D27100794	2	Spring	
88	D28283200	1	Shaft	
89	D28285535	2	Fork	
90	D40423900	X	Hex. Sock. Screw	
91	D28285531	1	Journal	
92	D45140038	2	Ring	[A]
108	D18283090	1	Plate	
109	D18283098	1	Fitting	
110	D40404900	X	Hex. Sock. Screw	
111	D20400506	X	Washer	
112	D41013500	X	Nut	
113	D18285215	1	Bracket	
152	D28285166	2	Bracket	
153	D40407900	4	Hex. Sock. Screw	
154	D20400507	8	Spacer	
155	D41087600	4	Locknut	
156	D28285162	1	Arm	Left Hand
156	D28285185	1	Arm	Right Hand
174	D20400537	2	Spacer	
177	D41087700	2	Locknut	
179	D28285270	2	Spring	
180	D41622700	1	Bear. 6204 2rs	Valid from machine/table no,can be used in new as well as in older machines 58241
181	D42513700	2	Circlip	Valid from machine/table no,can be used in new as well as in older machines 58241
182	D45702000	1	Hose	

FOOTNOTE [A] OPTIONAL EQUIPMENT

MF 7250/7252 COMBINE - 1637400
D-ZAZE-005-A

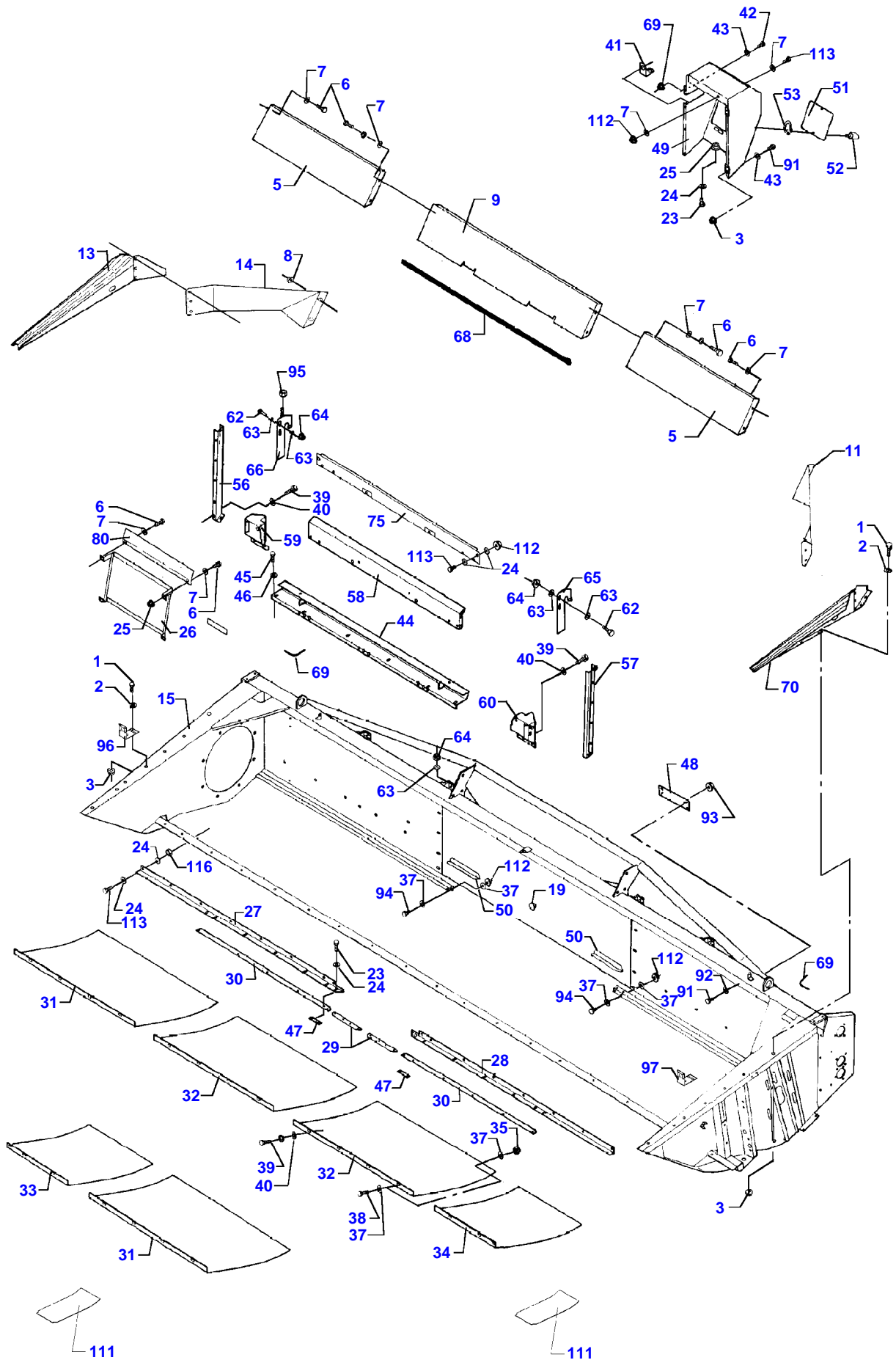

Buy Now



Our support email:

ebooklibonline@outlook.com