

Page Title	Page Number
Knives And Fingers - Freeflow	001-0001
Table Auger Right Hand - Freeflow	001-0002
Table Auger Left Hand - Freeflow	001-0003
Guarding And Transmissions - Freeflow	001-0004
Table Housing And Guarding - Freeflow	001-0005
Knives And Fingers - Powerflow	001-0006
Table Auger Right Hand - Powerflow	001-0007
Table Auger Left Hand - Powerflow	001-0008
Guarding And Transmissions - Powerflow	001-0009
Table Housing And Guarding - Powerflow	001-0010
Powerflow Band - Left Hand	001-0011
Powerflow Band - Right Hand	001-0012
Oilseed Rape Auger	001-0013
Straw Dividers	001-0014
Table Trailer - From No 0000500	001-0015
Lightening Bracket	001-0016
Electric Vertical Knife	001-0017

MF 7242 COMBINE - 1637439
D-ZAZA-007-B

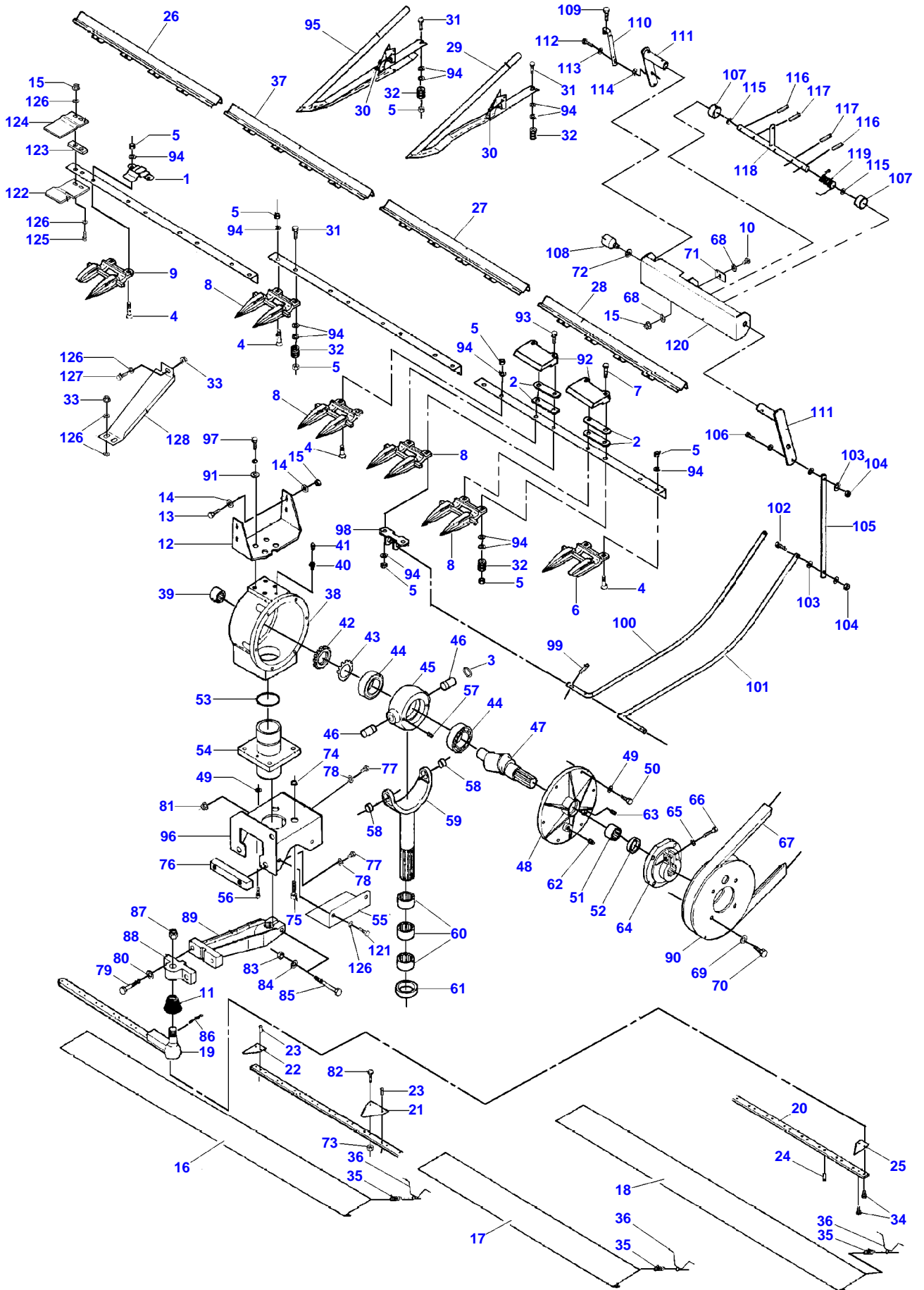

Knives And Fingers - Freeflow

Item	Part Number	Qty	Description	Comments
1	D28283934	11	Clip	12' - 3,72M
	D28283934	13	Clip	14' - 4,34M
	D28283934	15	Clip	16' - 4,95M
2	D28230292	4	Shim	
3	D45483000	1	O Ring	[C]
4	D40551500	X	Bolt	
5	339402X1	X	Nut	M10
6	D44104700	1	Finger	Left Hand
7	D40067600	X	Screw	
8	D44104500	25	Finger	12' - 3,72M
	D44104500	27	Finger	14' - 4,34M
	D44104500	31	Finger	16' - 4,95M
9	D44104600	1	Finger	Right Hand
10	339123X1	2	Hex. Sock. Screw	M8 X 20
11	D44120500	1	Cap	
12	D28283104	1	Support	
13	339337X1	2	Hex. Sock. Screw	M8 X 30
14	D20400414	4	Washer	
15	394367X1	12	Locknut	M8
16	D28230842	1	Guard	14' - 4,34M
	D28230845	1	Guard	16' - 4,95M
17	D28230843	1	Guard	
18	D28230844	1	Guard	
	D28230845	1	Guard	
19	D28283306	2	Blade	12' - 3,72M
	D28283307	2	Blade	14' - 4,34M
	D28283308	2	Blade	16' - 4,95M
	D28283011	2	Knife Head	
20	D28281488	2	Knife Back	12' - 3,72M
	D28281489	2	Knife Back	14' - 4,34M
	D28281490	2	Knife Back	16' - 4,95M
21	D44103700	X	Section	[D]
22	D44103800	2	Half Section	
23	D41306100	X	Rivet	[D]
24	D41306200	X	Rivet	[D]
25	D44104000	2	Half Section	Left Hand
26	D18283701	1	Stone Trap	Right Hand
27	D18283704	1	Stone Trap	16' - 4,95M
28	D18283702	1	Stone Trap	Left Hand
29	D49040200	X	Ear Lifter	
30	D49040400	X	Spring	
31	339019X1	X	Hex. Sock. Screw	M10 X 50
32	D49040600	X	Roller	
33	D41017500	3	Locknut	
34	339560X1	2	Hex. Sock. Screw	M6 X 16
35	D26500317	2	Spring	(16)
	D26500317	2	Spring	(17)
	D26500317	2	Spring	(18)
36	D28230841	2	Spring	(16)
	D28230841	2	Spring	(17)
	D28230841	2	Spring	(18)
37	D18283703	1	Stone Trap	14' - 4,34M
38	D28281324	1	Wobble Drive	[B]
	D44127800	1	Box	[B]
				(38)
	D28281324	1	Wobble Drive	[C]
				(38)
	D44126500	1	Box	[C]
				(38)
39	D44128800	1	Bearing Needle	(38)
40	D44129400	1	Connector	(38)
41	D46116500	1	Valve.	(38)
42	D44129100	1	Nut	(38)
43	D44129200	1	Washer	(38)
44	D41668400	2	Bearing Roller	(38)
45	D44127900	1	Housing	[B]
				(38)
	D44126400	1	Housing	[C]
				(38)
46	D44128000	2	Journal	[B]
				(38)

Item	Part Number	Qty	Description	Comments
46	D44125900	2	Journal	[C] (38)
47	D44129300	1	Shaft	(38)
48	D44128200	1	Cover	[B] (38)
48	D44126300	1	Cover	[C] (38)
49	D41102100	8	Washer	(38)
50	339123X1	6	Hex. Sock. Screw	(38) M8 X 20
51	D41669700	1	Bearing Needle	(38)
52	D45412000	1	Gasket	(38)
53	D45481500	1	O Ring	(38)
54	D44128300	1	Bearing Carrier	[B] (38)
54	D44126200	1	Bearing Carrier	[C] (38)
55		1	Guard	Replace and repair. Old not interchangeable with new D18281706
56	D40697200	2	Screw	[B] (38)
56	D40697700	2	Screw	[C] (38)
57	D40639600	2	Pin	[B] (38)
58	D44128400	2	Bush	[B] (38)
58	D44126100	2	Bush	[C] (38)
59	D44128500	1	Yoke	[B] (38)
59	D44126000	1	Yoke	[C] (38)
60	D41669800	3	Bearing Needle	(38)
61	D45409500	1	Gasket	(38)
62	D44128600	1	Plug	(38)
63	D45236200	1	Plug	(38)
64	D44127100	1	Hub	(38)
65	D41100900	1	Spring Washer	(38)
66	D40694000	1	Screw	(38)
67	D41985600	1	Belt	
68	D20400416	4	Washer	
69	D20400426	4	Washer	
70	1440716X1	4	Hex. Sock. Screw	M12 X 30
71	D28284268	2	Stop	
72	D20400441	1	Washer	
73	1441462X1	X	Locknut	Alternative D41306100 M6
74	D20400522	4	Spacer	
75	D40465400	4	Screw	
76	D28283103	1	Clamp	
77	390419X1	5	Hex. Sock. Screw	M16 X 40
78	D20400461	5	Washer	
79	D40698400	2	Screw	
80	D20400438	2	Washer	
81	1442739X1	2	Locknut	
82	339560X1	X	Hex. Sock. Screw	Alternative D41306100 M6 X 16
83	1442190X1	1	Locknut	
84	D20400428	1	Washer	
85	390826X1	1	Hex. Sock. Screw	
86	391423X1	1	Split Pin	4 X 40
87	D41054300	1	Nut	
88	D44126900	1	Flange	
89	D44127000	1	Swivel Arm	
90	D44127200	1	Pulley	
91	D28280986	4	Washer	
92	D28260362	X	Clip	
93	1441671X1	X	Screw Special	M10 X 50
94	D20400419	X	Washer	
95	D49040300	X	Ear Lifter	
96	D28283109	1	Support	Replace and repair. Old not interchangeable with new D18283109
97	339337X1	4	Hex. Sock. Screw	M8 X 30

Item	Part Number	Qty	Description	Comments
98	D28284356	4	Fitting	[A]
99	D42611800	8	Pin	[A]
100	D28284257	2	Sensor	[A]
101	D28284258	2	Sensor	[A]
102	D40405300	4	Screw	[A]
103	D20400506	20	Washer	[A]
104	394367X1	2	Locknut	[A] M8
105	D28284223	4	Link	[A]
106	339009X1	4	Hex. Sock. Screw	[A] M8 X 35
107	D28284456	4	Bush	[A]
108	D28780523	2	Potentiometer	[A]
109	D40464900	2	Screw	[A]
110	D28780845	2	Rod	[A]
111	D28284234	4	Lever	[A]
112	339804X1	2	Hex. Sock. Screw	[A] M6 X 25
113	D20400404	2	Washer	[A]
114	1441462X1	2	Locknut	[A] M6
115	D28200551	4	Washer	[A]
116	D42611900	8	Pin	[A]
117	D42612300	4	Pin	[A]
118	D28284232	2	Shaft	[A]
119	D28284389	2	Spring	[A]
120	D28284222	2	Support	AUTO LEVEL 16' - 4,95M
121	339124X1	2	Hex. Sock. Screw	M8 X 16
122	D28281576	1	Plate	
123	D28281575	1	Shim	
124	D28281574	1	Plate	
125	339010X1	2	Hex. Sock. Screw	
126	D20400506	7	Washer	
127	339761X1	1	Hex. Sock. Screw	M8 X 25
128	D18281572	1	Guard	

FOOTNOTE [A] OPTIONAL EQUIPMENT AUTO LEVEL

FOOTNOTE [B] USED ONLY IN KNIFE DRIVES WITH 6 HOLES IN BEARING HOUSING BOTTOM

FOOTNOTE [C] USED ONLY IN KNIFE DRIVES WITH 8HOLES IN BEARING HOUSING BOTTOM AND BULGES SIDES

FOOTNOTE [D] OPTIONAL

MF 7242 COMBINE - 1637439
D-ZAZB-007-B

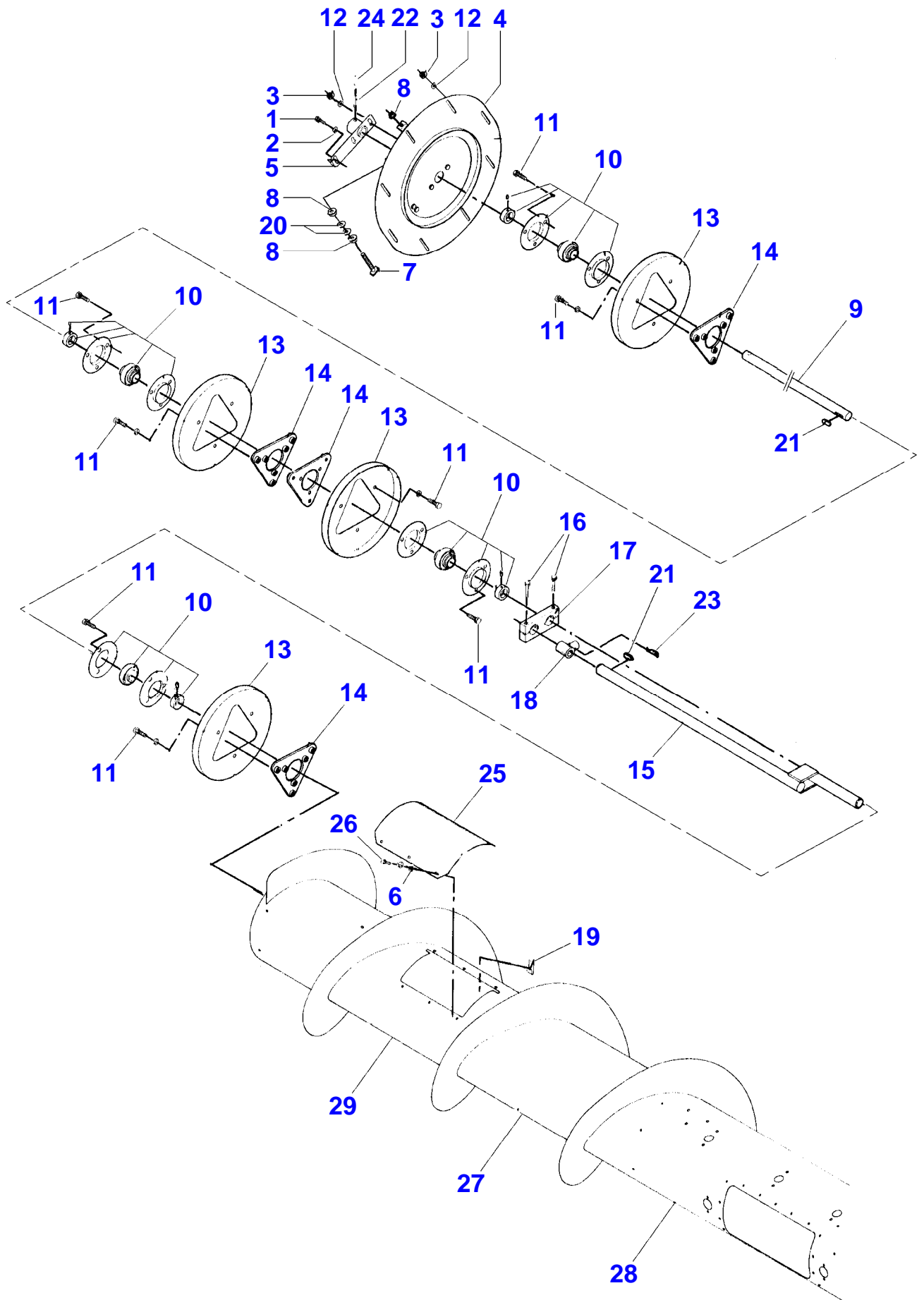

Item	Part Number	Qty	Description	Comments
1	339124X1	1	Hex. Sock. Screw	M8 X 16
2	D20400506	1	Washer	
3	D41017500	10	Locknut	
4	D18280040	1	Plate	
5	D28283029	1	Adjuster	
6	D20400470	6	Washer	Diameter 6
7	D28211023	1	Bolt	
8	1440329X1	2	Locknut	M10
9	D28283035	1	Shaft	12' - 3,72 M
	D28283767	1	Shaft	14' - 4,34 M
	D28283768	1	Shaft	16' - 4,95 M
10	D41707800	4	Bearing	
11	339814X1	24	Hex. Sock. Screw	M10 X 35
12	D20400414	X	Washer	
13	D28280014	4	Plate	
14	D28283847	4	Bearing Plate	
15	D28283016	1	Crankshaft	
16	339556X1	2	Hex. Sock. Screw	
17	D28283039	1	Arm	
18	D28251831	15	Bearing Carrier	
19	D43428200	6	Nut	
20	D20400471	2	Washer	
21	339441X1	2	Key Parallel	10 X 8 X 40 A
22	D42625300	1	Pin	13 X 56
23	D28283853	15	Hair Pin	
24	1441645X1	1	Pin	
25	D18283070	1	Cover	
26	339666X1	6	Hex. Sock. Screw	M6 X 20
27	D18285987	1	Table Auger	12' - 3,72 M
	D18283789	1	Table Auger	14' - 4,34 M
	D18283790	1	Table Auger	16' - 4,95 M
28	D28283012	1	Body	
29	D28286008	1	Body	Right Hand 12' - 3,72 M
	D28283792	1	Body	Right Hand 14' - 4,34 M
	D28283795	1	Body	Right Hand 16' - 4,95 M

MF 7242 COMBINE - 1637439
D-ZAZC-007-A

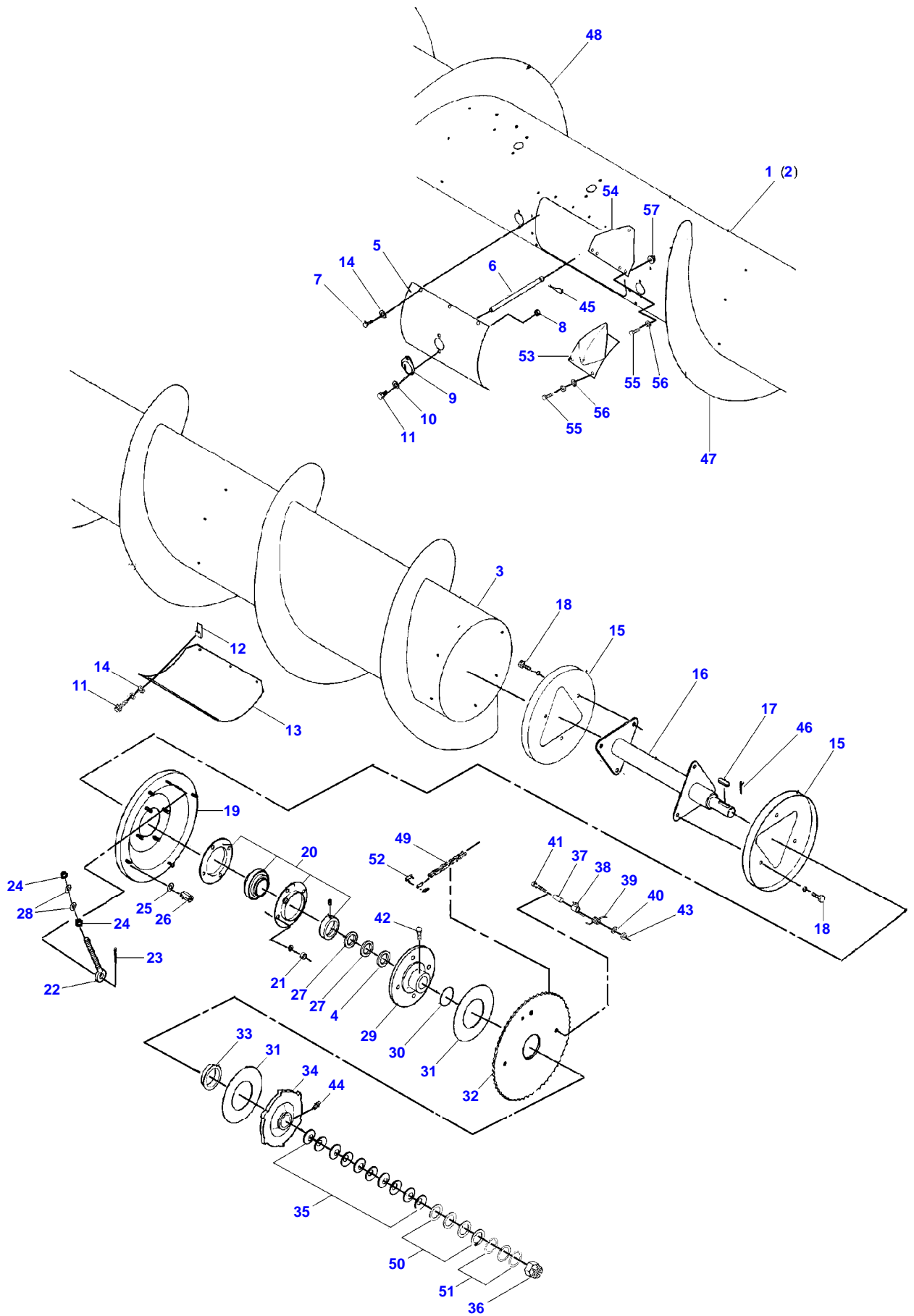
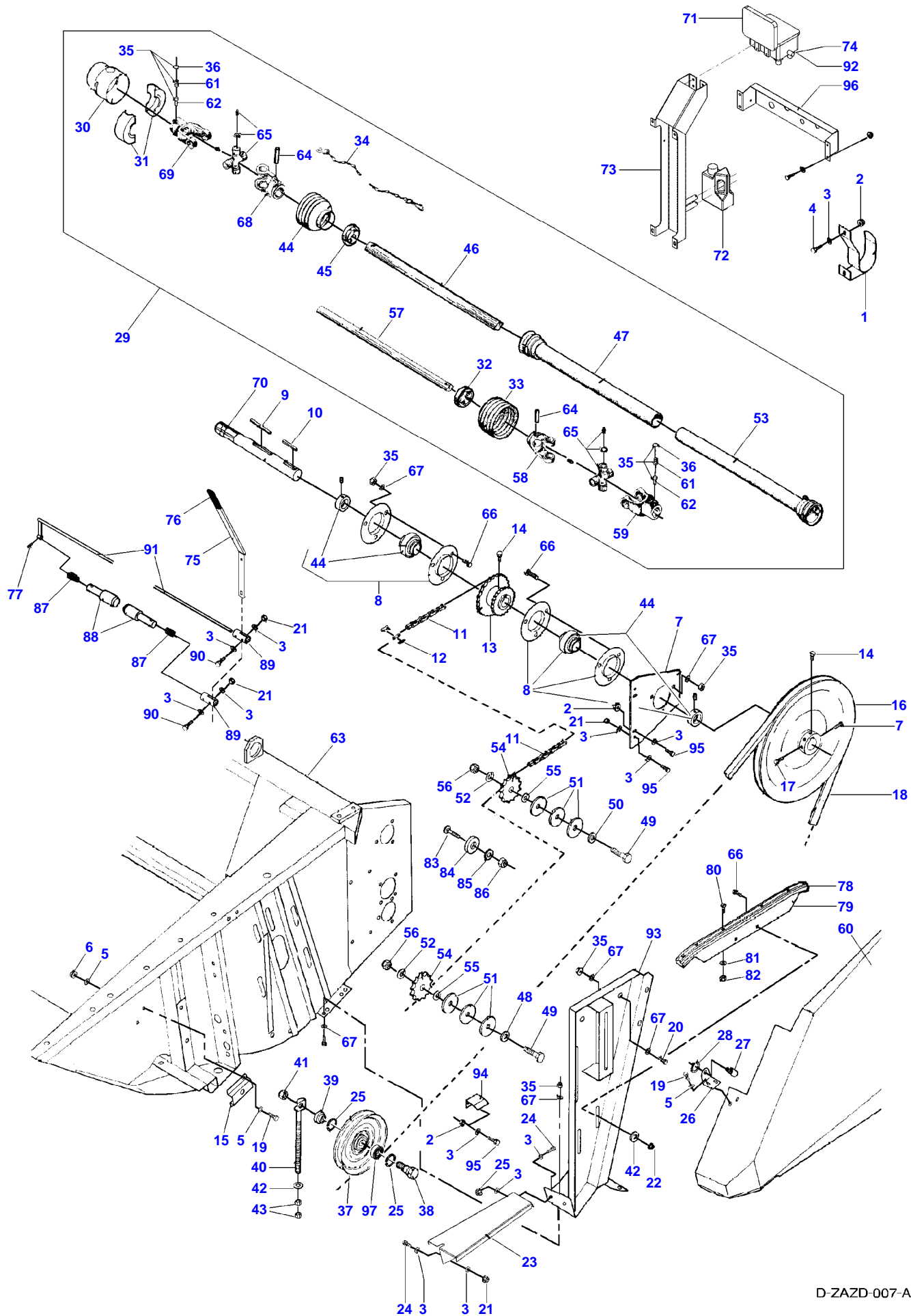

Table Auger Left Hand - Freeflow

Item	Part Number	Qty	Description	Comments
1	D18285987	1	Table Auger	12' - 3,72M
	D18283789	1	Table Auger	14' - 4,34M
	D18283790	1	Table Auger	16' - 4,95M
2	D28283012	1	Body	
3	D28285998	1	Body	Left Hand 12' - 3,72M
	D28283793	1	Body	Left Hand 14' - 4,34M
	D28283794	1	Body	Left Hand 16' - 4,95M
4	D41653500	X	Washer	OPTIONAL 40 X 50 X 1
5	D18283078	1	Cover	
6	D28283815	15	Finger	
7	339560X1	X	Hex. Sock. Screw	M6 X 16
8	1441462X1	X	Locknut	M6
9	D28283060	15	Bush	
10	D20400404	X	Washer	
11	339666X1	X	Hex. Sock. Screw	M6 X 20
12	D43428200	6	Nut	M20
13	D18283070	1	Cover	
14	D20400470	6	Washer	
15	D28280014	2	Plate	
16	D28283007	1	Drive Shaft	
17	D43106800	1	Key	
18	3009491X1	6	Hex. Sock. Screw	M10 X 20
19	D18283053	1	Plate	
20	D41716500	1	Bearing	
21	3009695X1	4	Nut	M12
22	D28281387	1	Screw	
23	3000197X1	1	Split Pin	4 X 32
24	339402X1	2	Nut	M10
25	D20400415	4	Washer	
26	D28280729	4	Nut	
27	D41653500	X	Washer	40 X 50 X 1
28	D20400471	2	Washer	
29	D28283004	1	Washer	
30	D45481600	1	O Ring	
31	D45904300	2	Facing	
32	D28286047	1	Sprocket	
33	D28286049	1	Insert	
34	D28286166	1	Clutch Disc	
35	D41112400	10	Washer	
36	D41054100	1	Castle Nut	
37	D28281431	1	Spacer	
38	D28281432	1	Support	
39	D28283006	1	Spring	
40	D20400507	1	Spacer	
41	339556X1	1	Hex. Sock. Screw	
42	339761X1	1	Hex. Sock. Screw	M8 X 25
43	1440329X1	1	Locknut	M10
44	1441858X1	1	Grease Nipple	M6
45	D28283853	15	Hair Pin	
46	391405X1	1	Split Pin	4 X 25
47	D28281448	1	Spiral	12' - 3,72M
	D28280988	1	Auger	14' - 4,34M
	D28280052	1	Auger	16' - 4,95M
48	D28281449	1	Spiral	12' - 3,72M
	D28280989	1	Auger	14' - 4,34M
	D28280054	1	Auger	16' - 4,95M
49	D42329300	1	Chain	
50	D20400520	4	Spacer	
51	D20400522	3	Spacer	
52	D42365100	1	Link	
53	D28283294	4	Spike	
54	D28281694	4	Threaded Part	
55	339123X1	20	Hex. Sock. Screw	M8 X 20
56	D20400506	20	Washer	
57	394367X1	12	Locknut	M8

MF 7242 COMBINE - 1637439
D-ZAZD-007-A



Item	Part Number	Qty	Description	Comments
1	D18281345	1	Stirrup	
2	394367X1	X	Locknut	
3	D20400506	X	Washer	
4	339124X1	X	Hex. Sock. Screw	M8 X 16
5	391038X1	X	Washer	
6	1441462X1	X	Locknut	M6
7	D18283099	1	Bearing Carrier	
8	D41707800	2	Bearing	
9	D43114900	1	Key	
10	1441579X1	1	Key Parallel	10 X 8 X 56
11	D42329300	1	Chain	
12	D42365100	1	Link	
13	D28280225	1	Sprocket	
14	D40697900	1	Screw	
15	D28281578	1	Retainer	
16	D28285423	1	Pulley	
17	D40697900	2	Screw	M10 X 25
18	D41985600	1	Belt	
19	339666X1	X	Hex. Sock. Screw	M6 X 20
20	3009492X1	4	Hex. Sock. Screw	M10 X 25
21	394367X1	X	Locknut	M8
22	1440329X1	X	Locknut	M10
23	D28281570	1	Plate	
24	339761X1	3	Hex. Sock. Screw	M8 X 25
25	339199X1	2	Circlip	47 X 1,75
26	D28281577	1	Angle.	
27	D43427500	1	Pin	
28	1440988X1	1	Circlip	
29	D45608800	1	Shaft	12' - 3,72M
	D45608900	1	Shaft	14' - 4,34M
	D45609000	1	Shaft	16' - 4,95M
30	D45632900	1	Bush	
31	D45633000	1	Ring	
32	D45630700	1	Ring	
33	D45630500	1	Guard	
34	D45681800	2	Chain	
35	D45632400	2	Tube	
36	D45645700	2	Washer	
37	D28760574	1	Pulley	Valid from machine/table no,can be used in new as well as in older machines 938215
38	D28760156	1	Screw	
39	D28760155	1	Bush	
40	D28260181	1	Bolt	
41	1442739X1	X	Locknut	
42	D20400416	X	Washer	
43	339402X1	X	Nut	M10
44	D45630400	1	Guard	
45	D45630600	1	Ring	
46	D45632800	1	Tube	16' - 4,95M
47	D45632600	1	Tube	16' - 4,95M
48	D28181284	1	Washer	
49	391889X1	2	Hex. Sock. Screw	M16 X 70
50	D20400463	1	Washer	
51	D20400460	6	Washer	
52	D20400459	2	Washer	
53	D45632100	1	Tube	14' - 4,34M
	D45632500	1	Tube	16' - 4,95M
54	D41716800	2	Tightener	
55	D20400516	X	Spacer	OPTIONAL
56	D41087900	2	Locknut	M16
57	D45632700	1	Tube	16' - 4,95M
58	D45630100	1	Yoke	
59	D45633200	1	Yoke	
60	D18281583	1	Guard	
61	D45667300	2	Spring	
62	D45665300	2	Pin	

Item	Part Number	Qty	Description	Comments
63	D18286022	1	Table	12' - 3,72M
63	D18285501	1	Table Housing	14' - 4,34M
63	D18285502	1	Table Housing	16' - 4,95M
64	D42619100	2	Pin	
65	D45630300	2	Hub	
66	D40066800	8	Screw Special	M10 X 30
67	D20400419	X	Washer	
68	D45630200	1	Yoke	
69	D45633100	1	Yoke	
70	D28284404	1	Shaft	
71	D28785641	1	Clutch	[A]
72	D45148900	1	Container	[A]
73	D28285296	1	Bracket	[A]
74	D45140037	2	Screw	[A]
75	D28285536	1	Lever	
76	D43484900	1	Lever	
77	D42612200	X	Pin	
78	D28280787	1	Rail	
79	D28281365	1	Crossmember	Replace and repair. Old not interchangeable with new D18281365
80	D40609300	6	Screw	
81	D20400466	6	Washer	4,3 X 9 X 0,8
82	D41087200	6	Locknut	M4
83	D40073100	1	Screw	
84	D28280981	1	Spacer	
85	D20400459	1	Washer	
86	1442739X1	1	Locknut	
87	D27100794	2	Spring	
88	D28283200	1	Shaft	
89	D28285535	2	Fork	
90	339168X1	X	Hex. Sock. Screw	M8 X 50
91	D28285531	1	Journal	
92	D45140038	2	Ring	[A]
93	D18283090	1	Plate	
94	D18283098	1	Fitting	
95	339123X1	X	Hex. Sock. Screw	M8 X 20
96	D18285215	1	Bracket	
97	339599X1	1	Bear. 6204 2rs	Valid from machine/table no,can be used in new as well as in older machines 938215

FOOTNOTE [A] OPTIONAL EQUIPMENT

MF 7242 COMBINE - 1637439
D-ZAZE-007-C

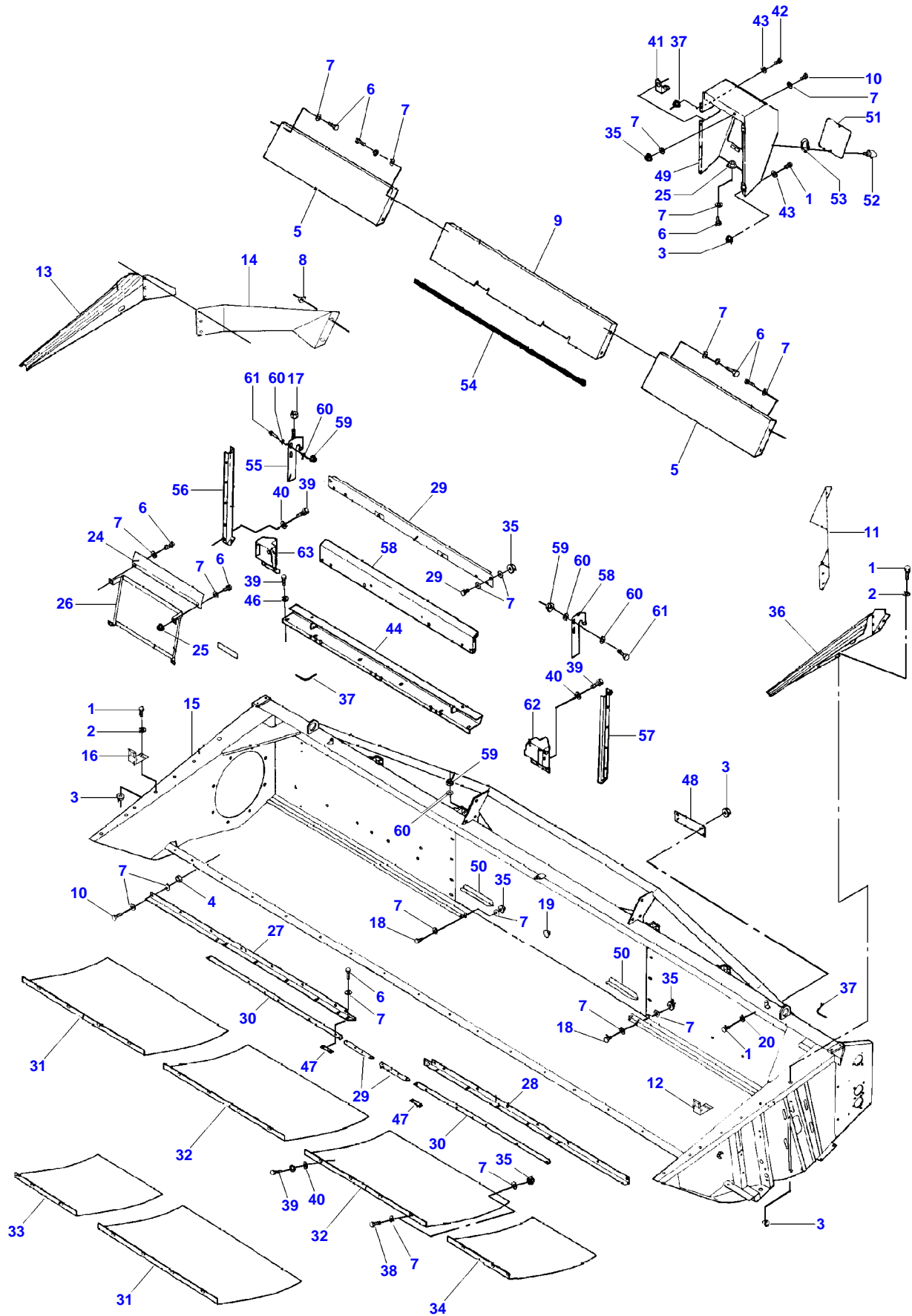

Item	Part Number	Qty	Description	Comments
1	339560X1	X	Hex. Sock. Screw	M6 X 16
2	391038X1	X	Washer	
3	1441462X1	X	Locknut	M6
4	339169X1	X	Nut	M8
5	D18283429	2	Cowl	12' - 3,72M
	D18283428	2	Cowl	14' - 4,34M
	D18283427	2	Cowl	16' - 3,95M
6	339123X1	X	Hex. Sock. Screw	M8 X 20
7	D20400506	X	Washer	
8	394367X1	X	Locknut	
9	D18283236	1	Cowl	
10	339761X1	X	Hex. Sock. Screw	M8 X 25
11	D18283233	1	Cowl	Left Hand
12	D28780381	1	Retainer	[B]
13	D18283516	1	Side	Right Hand
14	D18283232	1	Cowl	Right Hand
15	D18286022	1	Table	12' - 3,72M
	D18285501	1	Table Housing	14' - 4,34M
	D18285502	1	Table Housing	16' - 4,95M
16	D28780381	2	Retainer	[C]
17	339034X1	1	Nut	M16
18	339337X1	4	Hex. Sock. Screw	M8 X 30
19	D45745300	X	Plug	
20	D20400404	X	Washer	
21	339124X1	2	Hex. Sock. Screw	[A,D] M8 X 16
22	D28284249	1	Plate	[A,D]
23	D20400506	2	Washer	[A,D]
24	D18285765	1	Protector	12' - 3,72M
	D18285764	1	Protector	14' - 16' 4,34M - 4,95M
25	394367X1	X	Locknut	
26	D18285769	1	Bracket	12' - 3,72M
	D18285768	1	Bracket	14' - 16' 4,34M - 4,95M
27	D28282206	1	Deflector	Right Hand 12' - 3,72M Replace and repair. Old interchangeable with new D18281804
	D28282208	1	Deflector	Right Hand 14' - 4,34M Replace and repair. Old interchangeable with new D18282208
	D28281802	1	Deflector	Right Hand 16' - 4,95M Replace and repair. Old interchangeable with new D18281802
28	D28282205	1	Deflector	Left Hand 12' - 3,72M Replace and repair. Old interchangeable with new D18281803
	D28282207	1	Deflector	Left Hand 14' - 4,34M Replace and repair. Old interchangeable with new D18282207
	D28281801	1	Deflector	Left Hand 16' - 4,95M Replace and repair. Old interchangeable with new D18281801
29	D18285218	1	Plate	[A] 14' - 16' 4,34M - 4,95M
30	D28283241	2	Deflector	12' - 3,72M
	D28283327	2	Deflector	14' - 4,34M Replace and repair. Old interchangeable with new D18283327
	D28283326	2	Deflector	16' - 4,95M
31	D28283256	2	Wearplate	12' - 3,72M Replace and repair. Old interchangeable with new D18283256
	D28283256	1	Wearplate	14' - 4,34M Replace and repair. Old interchangeable with new D18283256
	D28283256	3	Wearplate	16' - 4,95M Replace and repair. Old interchangeable with new D18283256
32	D28283255	2	Wearplate	14' - 18' 4,34M - 5,56M Replace and repair. Old interchangeable with new D18283255
33	D28283253	1	Wearplate	Right Hand
34	D28283254	1	Wearplate	Left Hand Replace and repair. Old interchangeable with new D18283254
35	394367X1	X	Locknut	M8
36	D18283938	1	Plate	Left Hand
37	D28782178	X	Seal Section	Length 5 M
38	D40405300	X	Screw	
39	3009493X1	X	Hex. Sock. Screw	M10 X 30
40	D20400419	X	Washer	

Buy Now



Our support email:

ebooklibonline@outlook.com