

Page Title	Page Number
ENGINE INSTALLATION	1
ENGINE ELECTRICS	2
STARTER-LUCAS	3
ALTERNATOR-LUCAS	4
BATTERIES AND CABLES	5
COOLING SYSTEM	6
FUEL SYSTEM-FUEL TANK AND ATTACHMENTS	7
FUEL SYSTEM-FUEL FILTERS AND PIPES	8
FUEL SYSTEM-FUEL FILTER	9
AIR FILTER-DRY - DUAL ELEMENT	10
EXHAUST SYSTEM-VERTICAL	11
THROTTLE CONTROLS	12
CONSOLE ELECTRICS-FOOTSTEP MODELS	13
INSTRUMENT PANEL AND INSTRUMENTS	14
CLUTCH-PEDAL	15
CLUTCH-DUAL CLUTCH	16
12 SPEED SYNCHROMESH TRANSMISSION-HOUSING	17
12 SPEED SYNCHROMESH TRANSMISSION-FORK AND GEARSHIFT RAIL	18
12 SPEED SYNCHROMESH TRANSMISSION-INPUT SHAFT	19
12 SPEED SYNCHROMESH TRANSMISSION-MAIN SHAFT	20
12 SPEED SYNCHROMESH TRANSMISSION-COUNTER SHAFT	21
EPICYCLIC UNIT-HEAVY DUTY	22
SHIFT LEVERS-12 SPEED TRANSMISSION	23
4 WHEEL DRIVE CONTROLS	24
TRANSFER GEAR BOX-4 WHEEL DRIVE	25
SPACER-2 WHEEL DRIVE	26
BOLTING ARRANGEMENT-CENTRE HOUSING TO TRANS. CASE	27
DRIVE SHAFT-CENTRE HOUSING TO TRANS. CASE	28
DRIVE SHAFT-4 WHEEL DRIVE	29
REAR AXLE-CENTRE HOUSING	30
REAR AXLE-SIDE COVER-PTO	31
REAR AXLE-PTO DRIVE MECHANISM-TWO SPEED	32
REAR AXLE-DIFFERENTIAL	33
REAR AXLE-DIFFERENTIAL LOCK MECHANISM	34
REAR AXLE-HOUSING	35
REAR AXLE-SPEEDOMETER PICKUP - HAULAGE TRACTOR	36
DIFFERENTIAL LOCK CONTROLS	37
PTO CONTROLS	38
DIPSTICK	39
BRAKES-DISC BRAKES	40
BRAKES-SLAVE CYLINDER	41
BRAKES-HYDRAULIC PIPES	42
BRAKES-MASTER CYLINDER	43
BRAKES-PEDALS	44
BRAKES-HANDBRAKE	45
REAR WHEELS-SQUARE DISC	46
REAR WHEELS-PAVT	47
FRONT WHEELS-4 WHEEL DRIVE	48
FRONT AXLE 2 WHEEL DRIVE-AXLE SUPPORT	49
FRONT AXLE 2 WHEEL DRIVE-CENTRE BEAM AND SPINDLES	50
FRONT AXLE 4 WHEEL DRIVE-SUPPORT	51
FRONT AXLE 4 WHEEL DRIVE-INSTALLATION	52
FRONT AXLE 4 WHEEL DRIVE-HOUSING	53

FRONT AXLE 4 WHEEL DRIVE-STEERING CYLINDERS	54
FRONT AXLE 4 WHEEL DRIVE-FINAL DRIVE	55
FRONT AXLE 4 WHEEL DRIVE-DIFFERENTIAL - WITH HYDROLOCK	56
STEERING-STEERING WHEEL AND COLUMN	57
STEERING ORBITROL UNIT	58
STEERING HYDRAULIC LINES - TANDEM PUMP 2WD	59
STEERING HYDRAULIC LINES - TANDEM PUMP 4WD	60
STEERING AUXILIARY HYDRAULIC LINES - TANDEM PUMP	61
STEERING TANDEM PUMP - BOSCH	62
STEERING TANDEM PUMP - SUNDSTRAND HYDRATEC	63
STEERING TANDEM PUMP - BOSCH	64
STEERING-CYLINDER 2 WHEEL DRIVE	65
OIL COOLER-LIVE PTO	66
OIL COOLER-LIVE PTO - TWO WHEEL DRIVE	67
OIL COOLER-LIVE PTO - FOUR WHEEL DRIVE	68
HYDRAULIC LIFT PUMP-PUMP	69
HYDRAULIC LIFT PUMP-STRAINER UNIT	70
HYDRAULIC LIFT-LIFT COVER	71
HYDRAULIC LIFT-LIFT ARMS	72
HYDRAULIC LIFT-QUADRANT SUPPORT	73
REAR CONTROLS-DRAFT AND POSITION	74
REAR CONTROLS-RESPONSE	75
SPOOL VALVE-SPOOL VALVE INSTALLATION - SPRING RETURN TO NEUTRAL	76
SPOOL VALVE-VALVE - SPRING RETURN TO NEUTRAL	77
SPOOL VALVE-CONTROLS AND SUPPORT	78
SPOOL VALVE-PIPES AND FITTINGS	79
SELECTOR VALVE MK3A-VALVE	80
SELECTOR VALVE MK3A-CONTROLS	81
TRAILER BRAKES-TRAILER BRAKE VALVE INSTALLATION	82
TRAILER BRAKES-TRAILER BRAKE VALVE INSTALLATION	83
TRAILER BRAKES-VALVE	84
TRAILER BRAKES-VALVE	85
TRAILER BRAKES-PIPES AND FITTINGS	86
LINKAGE-TOP LINK CAT 1 AND 2	87
TOP LINKS-STOWAGE HOOK	88
LINKAGE-LOWER LINKS CAT 1 AND 2	89
SHEET METAL-GRILLE	90
SHEET METAL-HOOD	91
SHEET METAL-PANELS	92
BULKHEAD	93
GUARD-PTO	94
TOOL BOX	95
EMBLEMS	96
DECALS	97
LITERATURE	98
FENDERS AND SUPPORTS-FLAT TOP	99
RETAINER PLATES - FENDER OR CAB-LESS STABILISERS	100
FOOTSTEP	101
SEAT-GRAMMER	102
LIGHTING EQUIPMENT-FRONT	103
LIGHTING EQUIPMENT-REAR	104

3-AA02-006-A

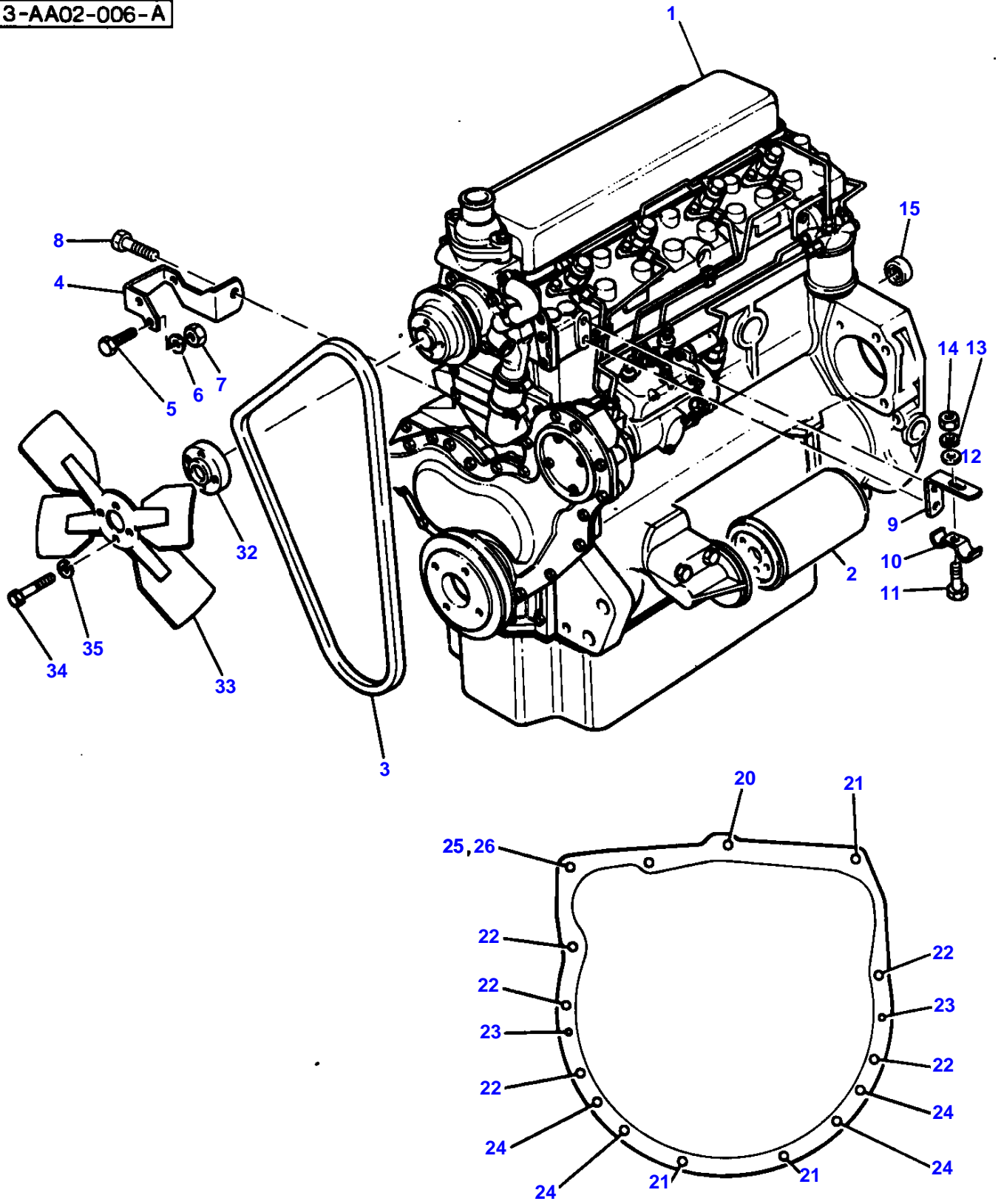

ENGINE INSTALLATION

Item	Part Number	Qty	Description	Comments
1		1	Engine	LOCAL SUPPLY
2		1	Oil Filter	LOCAL SUPPLY
3	1693745M1	1	V Belt	
4	1694276M3	1	Bracket	
5	376334X1	1	Screw Unc	
6	353775X1	1	Washer	
7	355565X1	1	Nut Unc	
8	353536X1	1	Screw Unf	
9	1696465M2	1	Bracket	
10	1696871M1	1	Clip	
11	339123X1	1	Screw Metric	
12	390972X1	1	Washer Metric	
13	339374X1	1	Lock Washer	
14	339169X1	1	Nut Metric	
15	828123M1	1	Bearing Assy	
20	3019858X1	1	Bolt Metric	
21	3019851X1	3	Bolt Metric	
22	3019853X1	5	Bolt Metric	
23	825302M1	2	Dowel	
24	3019855X1	4	Bolt Metric	
25	3019878X1	1	Bolt Metric	
26	3019862X1	2	Nut Metric	
32	37413581	1	Extension	
33	1695933M1	1	Fan	
34	353521X1	4	Bolt Unf	
35	353446X1	4	Lock Washer	

3-AC21-005-B

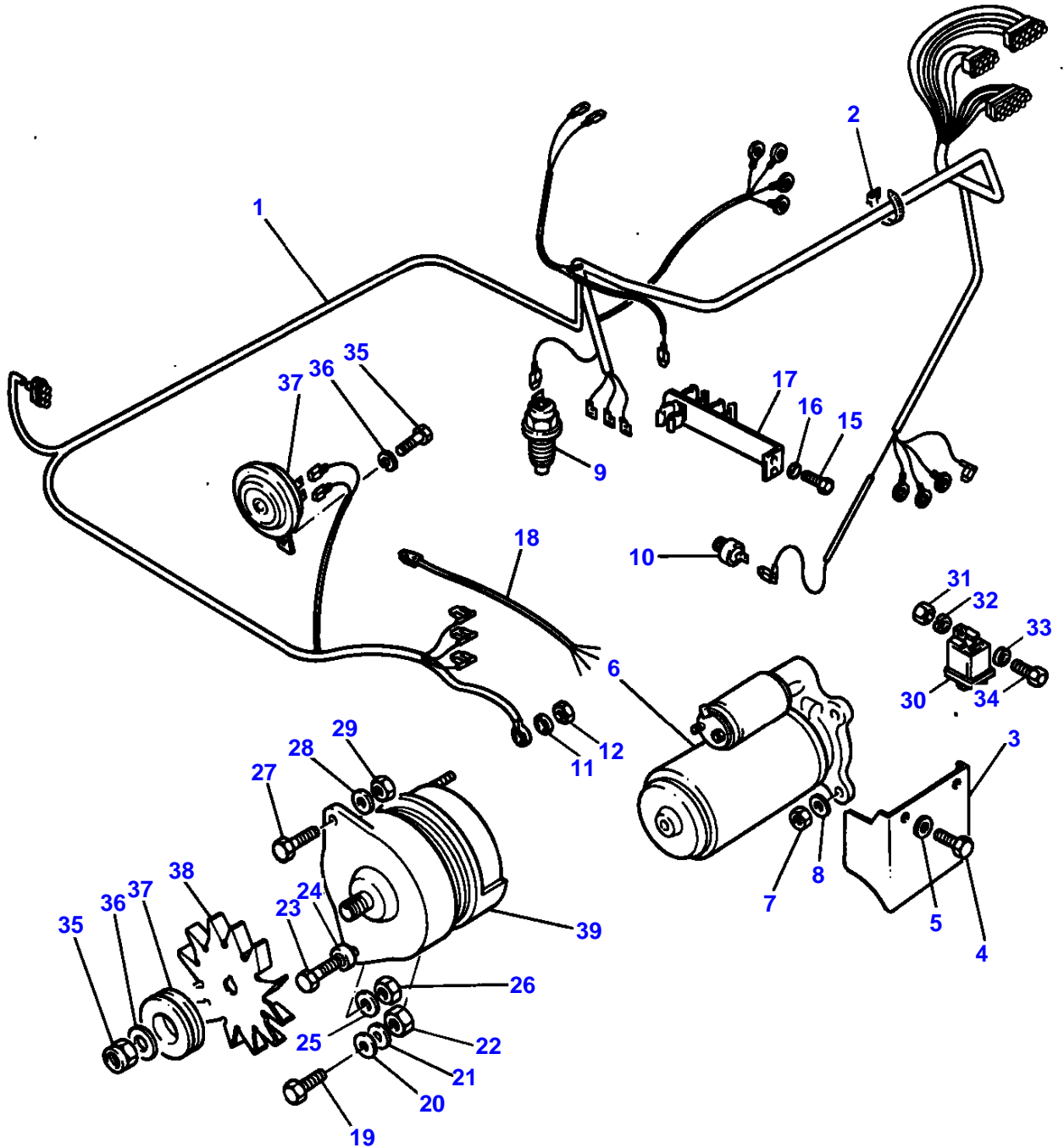

ENGINE ELECTRICS

Item	Part Number	Qty	Description	Comments
1	3598247M91	1	Harness	Up to Serial or Engine Number
	3612861M91	1	Wiring Harness	From Serial or Engine Number
2	1670082M1	2	Cable Tie	
3	3596175M1	1	Cover	
4	339124X1	2	Screw Metric	
5	390972X1	2	Washer Metric	
6	1868285M3	1	Startermotor	See Page - Reference Number 3/1
6	1691806M1	1	Startermotor	POWERPART PERKINS
7	353431X1	3	Nut Unf	
8	353434X1	3	Lock Washer	
9	1877731M92	1	Sender	"WATER TEMP"
10	3599307M91	1	Pressure Switch	"OIL PRESSURE"
11	3006155X1	1	Washer Metric	
12	390995X1	1	Nut Metric	
15	339560X1	2	Screw Metric	
16	339375X1	2	Lock Washer	
17	3598288M91	1	Bracket	
18	3598465M91	1	Harness	
19	339010X1	1	Bolt Metric	
20	391039X1	1	Washer Metric	
21	390972X1	1	Washer Metric	
22	339169X1	1	Nut Metric	
23	339337X1	1	Screw Metric	
24	3598553M1	1	Spacer	
25	390972X1	1	Washer Metric	
26	339169X1	1	Nut Metric	
27	339337X1	1	Screw Metric	
28	390972X1	1	Washer Metric	
29	392309X1	1	Nut Metric	
35		1	Nut	(A)
36		1	Washer	(A)
37	3600182M1	1	Pulley	
38	3600184M1	1	Fan	
39	3477851M91	1	Alternator	
45	339124X1	1	Screw Metric	
46	339374X1	1	Lock Washer	
47	1678404M1	1	Horn	
50	1897708M91	X	Kit	(B)

(A)  
CONTAINED IN KIT 1897 708 M91

(B)  
CONTAINS ITEMS MARKED (A)

3-AC04-004-A

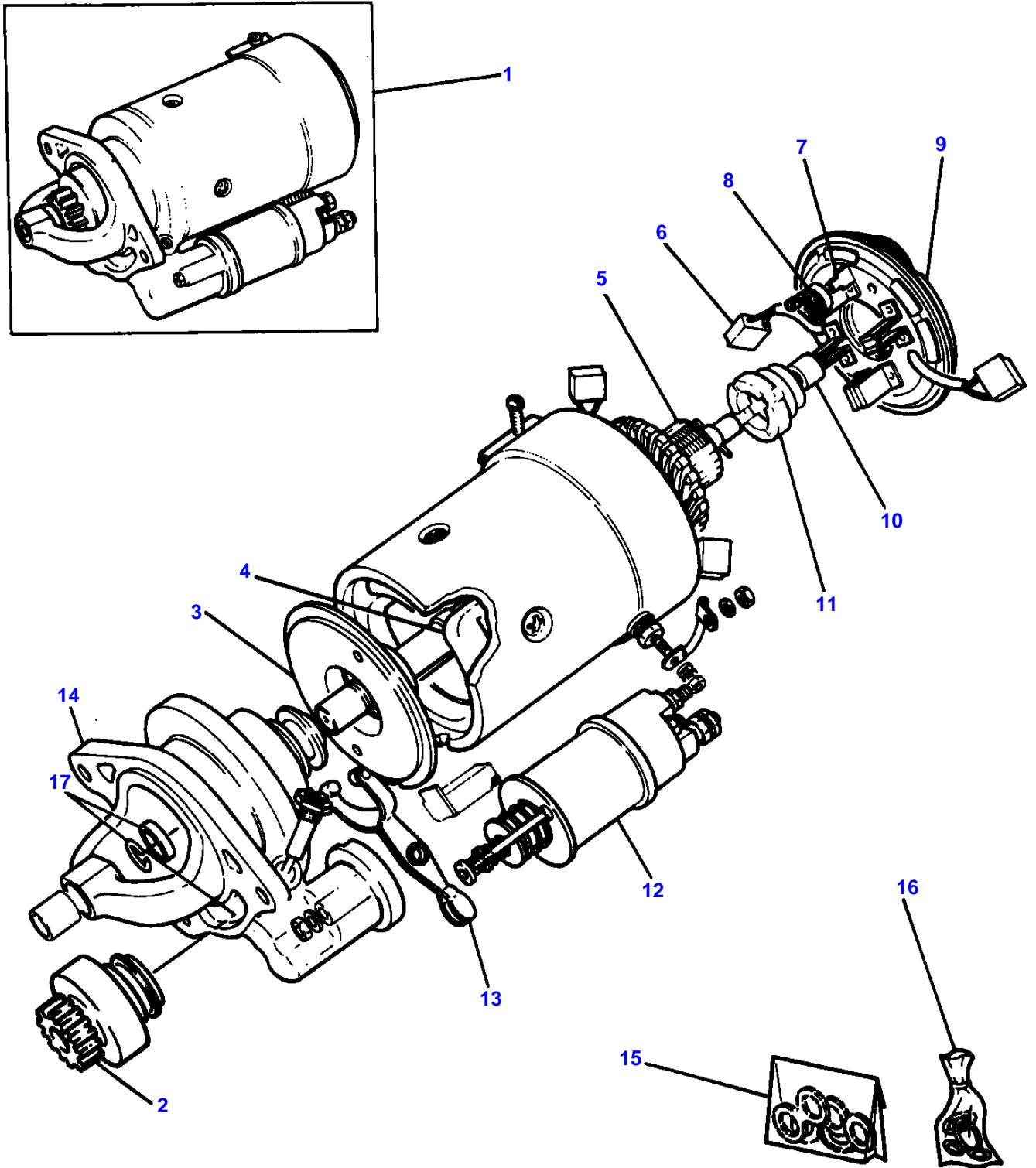

STARTER-LUCAS

Item	Part Number	Qty	Description	Comments
1	1868285M3	1	Startermotor	See Page - Reference Number 2/6
2	1897316M91	1	Drive	(1)
3	1810615M91	1	Bearing Plate	(1)
4	1897314M91	1	Coil	(1)
5	1897315M91	1	Armature	(1)
6	1810743M91	1	Kit, Brush	(1)
7	1887952M91	1	Kit, Brush Plate	(1)
8	1039134M91	1	Kit, Spring	(1)
9	1806009M1	1	Housing	(1)
10	1887955M91	1	Kit, Bush	(1)
11	1887956M91	1	Kit, Brake	(1)
12	3474587M1	1	Solenoid	(1)
13	1897317M92	1	Kit, Lever	(1)
14		1	Bearing Carrier	(1)
				Not serviced, order REF.1
15	1887967M91	1	Kit, Sundry	(1)
16	1806002M1	1	Kit, Seal	(1)
17	1893978M91	1	Kit, Retainer	(1)



3-AC22-002-A

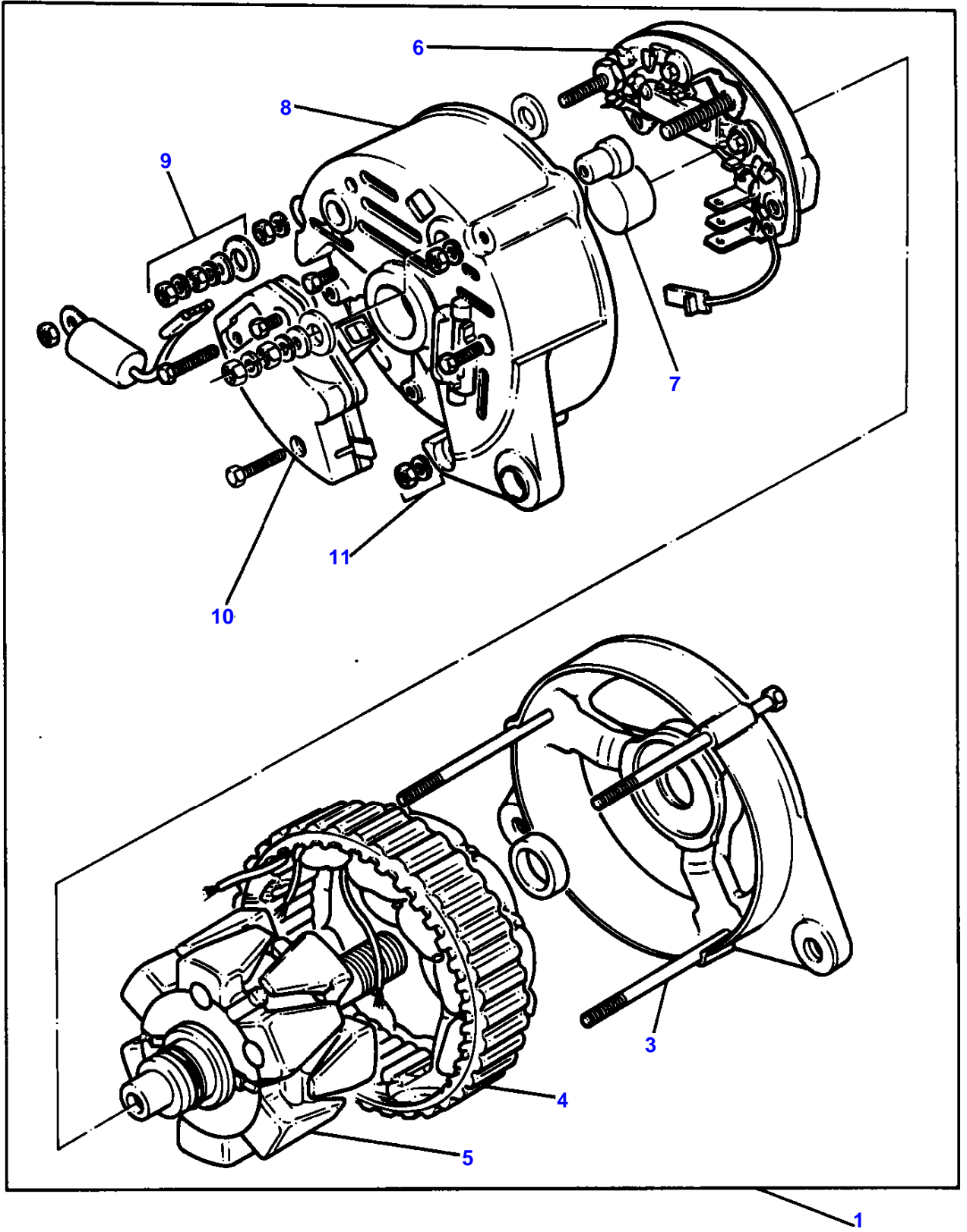

ALTERNATOR-LUCAS

Item	Part Number	Qty	Description	Comments
1	1897695M91	1	Alternator	See Page - Reference Number 2/29
2	1897701M91	1	Support	(1)
3		X	Bolt	(1) (A)
4	1897705M1	1	Stator	(1)
5	1897702M91	1	Rotor	(1)
6	3474648M91	1	Rectifier	(1)
7	1897704M1	1	Bearing Assy	(1)
8	1897703M1	1	Support	(1)
9	1897709M91	1	Kit	(1)
10	3475773M91	1	Regulator	(1)
11		X	Nut	(1) (A)
12	1897707M91	X	Kit	(B)

(A)  
INCLUDED IN KIT MARKED (B)

(B)  
INCLUDES ITEMS MARKED (A)

3-AC16-004-B

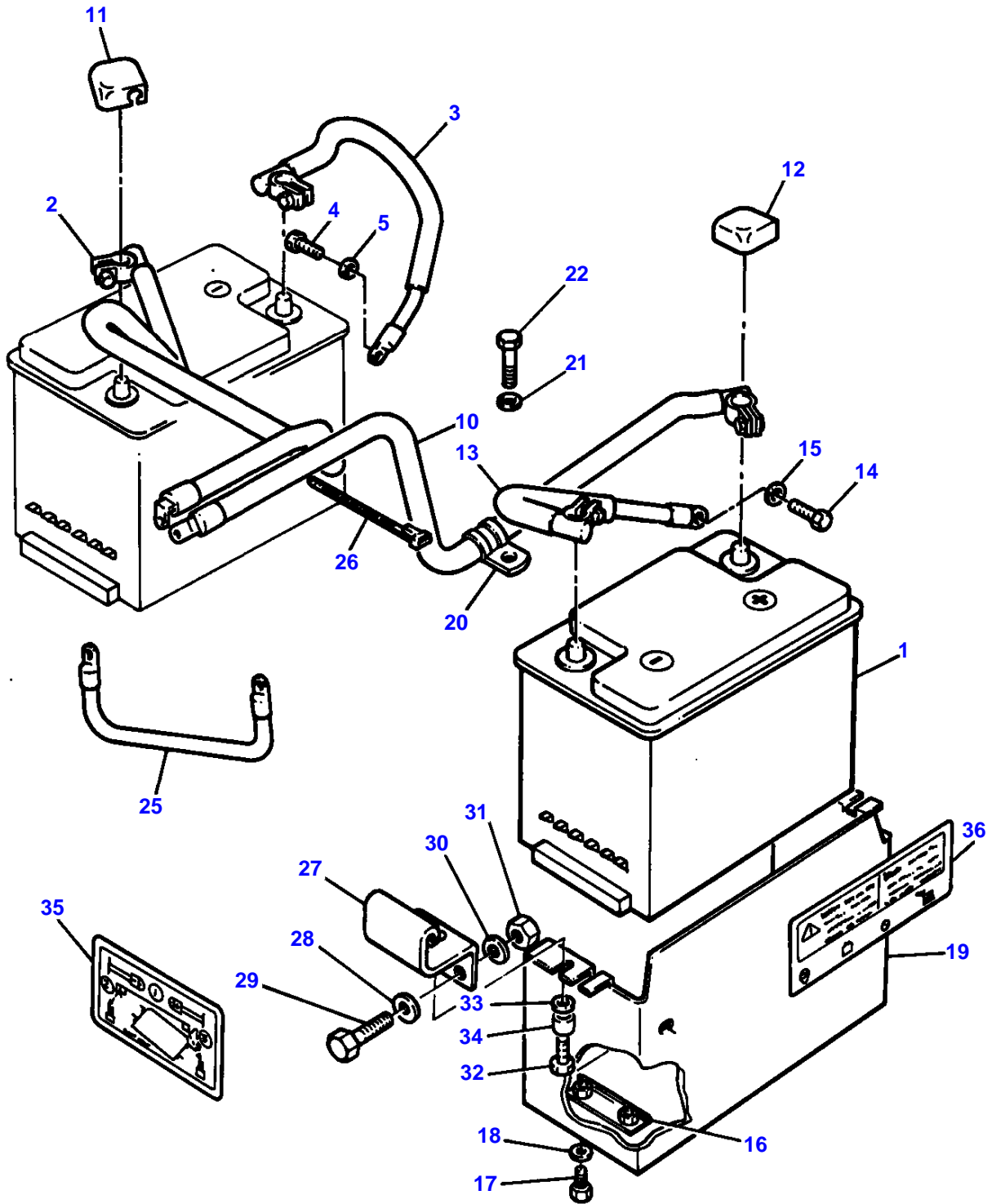

BATTERIES AND CABLES

Item	Part Number	Qty	Description	Comments
1	1695166M1	2	Tt Battery 372	(A)
2	3597508M91	1	Cable	Right Hand
3	3597510M91	1	Cable	Left Hand
4	353695X1	1	Screw Unc	
5	22465X	1	Lock Washer	
10	3597508M92	1	Cable	Left Hand
11	1695019M1	1	Cover	
12	3595747M1	1	Cover	
13	3597682M91	1	Cable	Right Hand
14	353695X1	1	Screw Unc	
15	22465X	1	Lock Washer	
16	3596769M91	4	Strap	
17	339262X1	8	Bolt Metric	
18	390971X1	8	Washer Metric	
19	1695020M95	2	Battery Box	
20	1684824M1	1	Clip	
21	353432X1	1	Lock Washer	
22	353695X1	1	Screw Unc	
25	3595742M93	1	Cable	Alternative 3595743M93
	3595743M93	1	Cable	Alternative 3595742M93
26	1670082M1	1	Cable Tie	
27	3596682M1	2	Bracket	
28	390971X1	4	Washer Metric	
29	339560X1	4	Screw Metric	
30	339375X1	4	Lock Washer	
31	339030X1	4	Nut Metric	
32	339368X1	4	Bolt Metric	
33	390972X1	2	Washer Metric	
34	3596686M1	2	Spacer	
35	3596786M2	1	Decal	Left Hand
	3596787M2	1	Decal	Right Hand
36	3596959M1	1	Decal	

(A)  
DRY

3-AC10-004-B

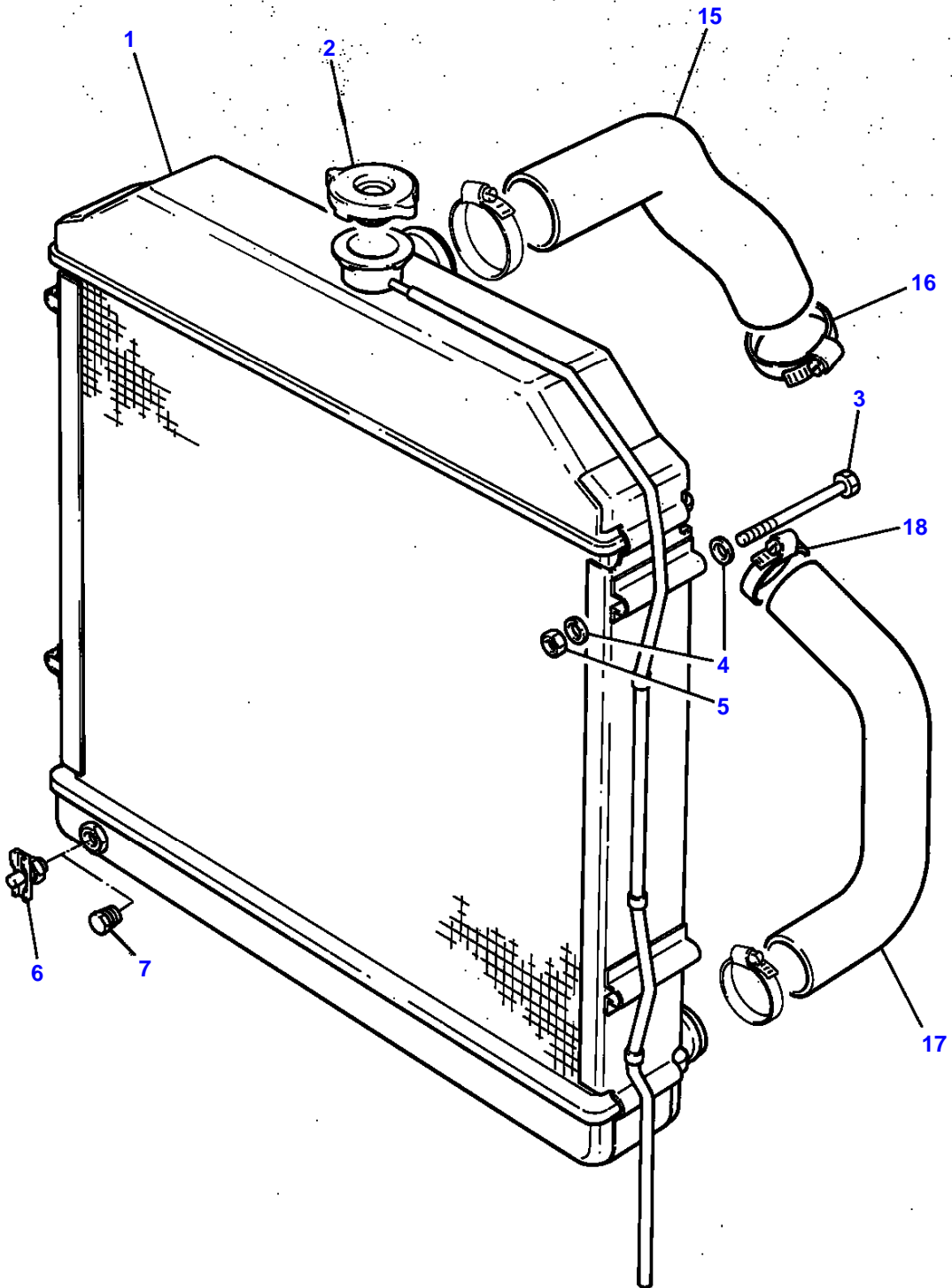

COOLING SYSTEM

Item	Part Number	Qty	Description	Comments
1	1695721M2	1	Radiator	
2	180224M92	1	Radiator Cap	
3	339013X1	4	Bolt Metric	
4	390972X1	8	Washer Metric	
5	394367X1	4	Locknut	
6	1851095M2	1	Tap	Not serviced, order REF.7
7	376670X1	1	Plug	Repairs and replaces 1851095M2
15	3596204M1	1	Hose	
16	338616X1	2	Hose Clip	
17	1695562M1	1	Hose	
18	338617X1	2	Hose Clip	

**Buy Now**



Our support email:

[ebooklibonline@outlook.com](mailto:ebooklibonline@outlook.com)