

Page Title	Page Number
CYLINDER BLOCK - A4.248	2
CRANKSHAFT AND FLYWHEEL - A4.248	4
CYLINDER HEAD AND COVER - A4.248	6
ROCKER ARM - A4.248	8
TIMING GEAR - A4.248	10
LUBRICATING OIL SYSTEM - OIL SUMP - A4.248	12
LUBRICATING OIL SYSTEM - OIL SUMP - A4.248	14
BALANCER UNIT - A4.248	15A
BALANCER UNIT - A4.248	15C
BALANCER UNIT - A4.248	15E
LUBRICATING OIL FILTER	15G
WATER PUMP AND FAN - A4.248	16
FUEL PIPINGS - A4.248	20
LIFT PUMP	24
FUEL FILTER AND HEATER PIPINGS	26
STARTER MOTOR	28
STARTER MOTOR - LUCAS	29A
STARTER MOTOR - PERKINS	29C
ALTERNATOR	30
KIT GASKET - A4.248	32
ENGINE - A4.248	34
FUEL PIPINGS	36
FUEL TANK	38
RADIATOR	40
INDUCTION MANIFOLD	42
WET AIR FILTER - LAUTRETTE	44
WET AIR FILTER - MOTOFIDES TYPE	46
DRY AIR CLEANER	48
DRY AIR CLEANER	50
EXHAUST MANIFOLD AND MUFFLER	52
ENGINE CONTROLS	54
ELECTRICAL EQUIPMENT	58
BATTERY	62
LIGHTS	64
INSTRUMENT PANEL	66
DUAL CLUTCH - LUK TYPE	68
DUAL CLUTCH - O.M.G.	70
CLUTCH CONTROL	72
CENTRE AXLE HOUSING AND TRANSMISSION HOUSING	76
SYNCHRO-MESH TRANSMISSION	80
CONTROLS AND TRANSMISSION LEVERS	84
REDUCER	88
REDUCER CONTROL	90
POWER TAKE OFF - STD LINKAGE	92
POWER TAKE OFF - 540/750/1000 RPM	94
DIFFERENTIAL	98
REAR AXLE-HOUSING	100
REAR AXLE-HOUSING - HEAVY DUTY	102
DIFFERENTIAL LOCK	104
BRAKES	106
BRAKES	110
HAND BRAKE	114
HAND BRAKE	116
HAND BRAKE	120
BRAKES PUMP	124
BRAKES PUMP	125A
BRAKES CYLINDER	126
BRAKES CYLINDER	127A
BRAKES CYLINDER	128
RIM AND TIRES	130
FRONT AXLE - 2 WHEEL DRIVE	134
STEERING HYDRAULIC EQUIPMENT	136
STEERING CONTROL VALVE	142
STEERING CONTROL VALVE - 2 WHEEL DRIVE	143A
STEERING CONTROL VALVE - 4 WHEEL DRIVE	143C
STEERING PUMP	144

TABLE OF CONTENT

STEERING CYLINDER - 2 WHEEL DRIVE	146
STEERING CYLINDER - 4 WHEEL DRIVE	148
HYDRAULIC LIFT PIPINGS	150
OIL PUMP - HYDRAULIC LIFT	154
HYDRAULIC CONTROL VALVE - HYDRAULIC LIFT	156
HYDRAULIC CONTROL VALVE - HYDRAULIC LIFT	158
HYDRAULIC LIFT	160
LIFT CONTROL	166
LIFT CONTROL	170
CONTROL SENSIBILITY	174
CONTROL SENSIBILITY	176
CYLINDER FOR HYDRAULIC LIFT	178
CYLINDER FOR HYDRAULIC LIFT	180
CYLINDER FOR HYDRAULIC LIFT SUPPLEMENTARY	182
LIFT CYLINDER SUPPLEMENTARY	184
PIPINGS AUXILIARY VALVE	186
PIPINGS AUXILIARY VALVE - 3 CONTROL VALVES	188
PIPINGS AUXILIARY VALVE - 3 CONTROL VALVES	191A
VALVE FOR CONTROL VALVE AUXIL.	191C
CYLINDER FOR HYDRAULIC LIFT	191E
CYLINDER FOR HYDRAULIC LIFT	191G
AUXILIARY HYDRAULICS VALVE	192
AUXILIARY HYDRAULICS VALVE - STD LINKAGE	194
AUXILIARY HYDRAULICS VALVE - FLOATING	196
VALVES - HYDRAULIC	198
VALVES - HYDRAULIC	200
LINKAGE CAT. II	202
FRONT AND REAR HOOK	206
REAR HOOK	208
REAR HITCH - ADJUSTABLE	210
REAR HOOK - STD LINKAGE	214
DRAWBAR	215A
MOUNTING FRAME AND FRONT WEIGHTS	216
HARDNOSE AND GRILLES	218
ENGINE HOOD	220
HOOD BRACKET AND INSTRUMENT PANEL	224
FENDERS AND PLATFORM BRACKETS	226
FENDERS AND PLATFORM	228
FRONT FENDERS	232
SAFETY FRAME AND II DEG PASSENGER SEAT	234
SEAT - LUX TYPE	236
SEAT - GRAMMER	239C
DECALS AND EMBLEMS	240
TRANSFER GEAR BOX - 4 WHEEL DRIVE	244
TRANSFER GEAR BOX - 4 WHEEL DRIVE	246
FRONT AXLE - HOUSING-DIFFERENTIAL-CAT I	250
FRONT AXLE - FINAL DRIVE	254
TOOL GROUP	258
CAB - UPPER AND BOTTOM FRAME	260
CAB - DOORS	264
CAB - WINDOWS	270
CAB - WINDSCREEN WIPER AND WIRING	274
CAB - INSULATOR AND FACING	278
CAB - HEATER	280
CAB - UPPER AND BOTTOM FRAME	284
CAB - DOORS	286
CAB - RETRO CAB	288
CAB - WINDOWS	290
CAB - WINDSCREEN WIPER AND MIRROR	292
CAB - HEATER	294

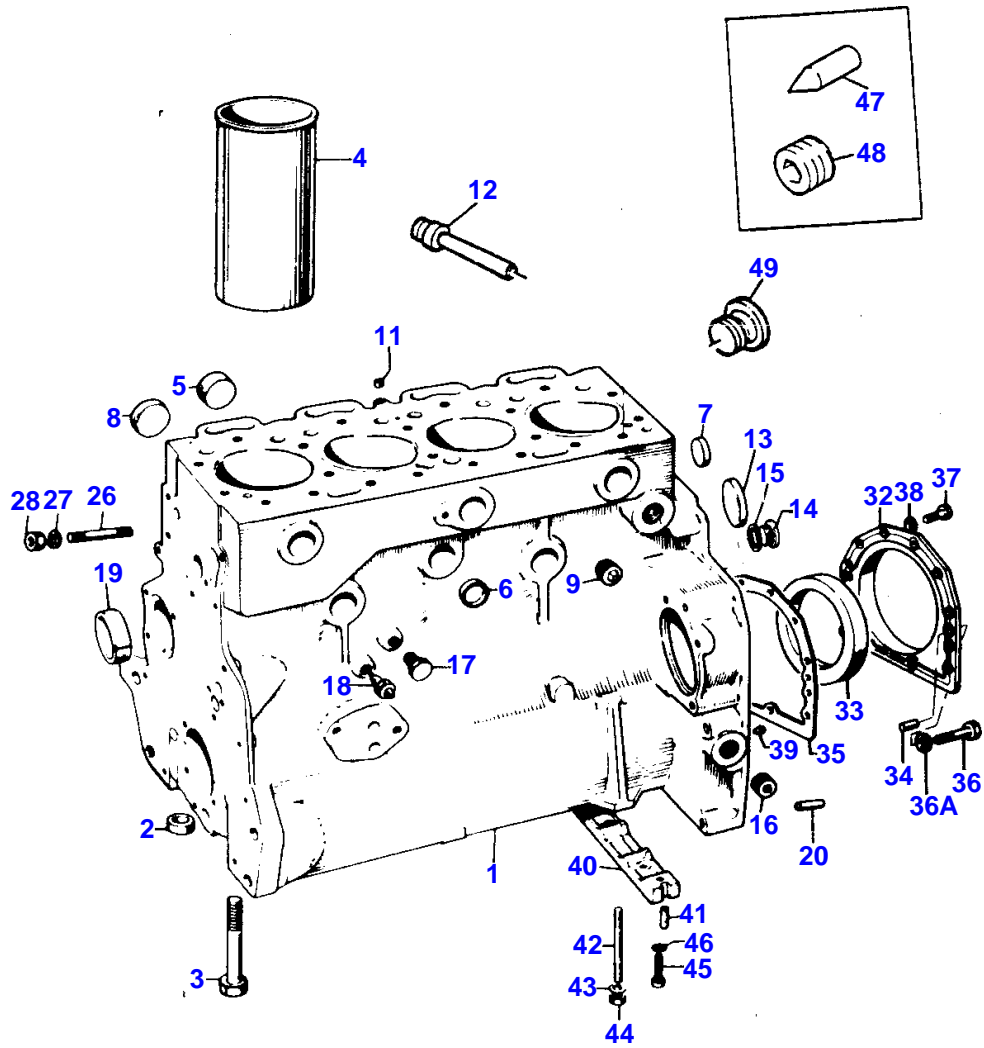

MASSEY FERGUSON

MF 294 S TRACTOR - 3301612

3301612

CYLINDER BLOCK - A4.248

2

Item	Part Number	Qty	Description	Comments
				A4.248
1	ZZ50076	1	Kit,Cyl.Block	Up to Serial or Engine Number
	ZZ50116	1	Kit,Cyl.Block	From Serial or Engine Number
2	33142111	10	Thimble	1
3	32166329	10	Bolt	1
4	31358352	X	Liner	Up to Serial or Engine Number U08336N (B)
4	3135X034	X	Liner	From Serial or Engine Number U08337N (B)
4	31358346	4	Liner	Up to Serial or Engine Number U08336N (A)
				1
4	3135X033	4	Liner	From Serial or Engine Number U08337N (A)
				1
5	0650618	4	Plug	1
6	0650563	6	Plug	1
7	0650563	2	Plug	1
8	0650577	4	Plug	
9	0650588	2	Plug	
11	32417134	1	Plug	
12	2485A204	1	Plug	1
13	32416105	1	Plug	
14	0650582	1	Plug	
15	0920130	1	Washer	
16	0650588	1	Plug	
17	2431131	1	Plug	Up to Serial or Engine Number
	0650594	1	Plug	From Serial or Engine Number
18	1423895M91	1	Switch	Up to Serial or Engine Number 1250754/2253781
	1877721M92	1	Pressure Switch	From Serial or Engine Number 1250755/2553782
19	31134132	1	Bush	
20	0350018	2	Dowel	
26	0826469	1	Stud	
27	0920054	1	Washer	
28	0576051	1	Nut	
32	4142V061	1	Kit, Housing	
33	2418F475	1	Seal	32
34	0350009	2	Dowel	
35	36817157	1	Joint	
36	2172530	2	Capscrew	
36A	33112111	2	Washer	
37	0746211	10	Bolt	
38	0920003	10	Washer	
39	32452113	1	Pointer	
40	36277831	1	Bridge Piece	
41	32811408	2	Joint	
42	32517128	2	Stud	
43	0920053	2	Washer	
44	0576002	2	Nut	
45	2176369	2	Screw	
46	0920521	2	Washer	
47	32452113	1	Pointer	
48	0650588	1	Plug	
49	32161114	3	Plug	Repairs and replaces 31261357 (A) PRESS FITTING (B) SLIP FIT

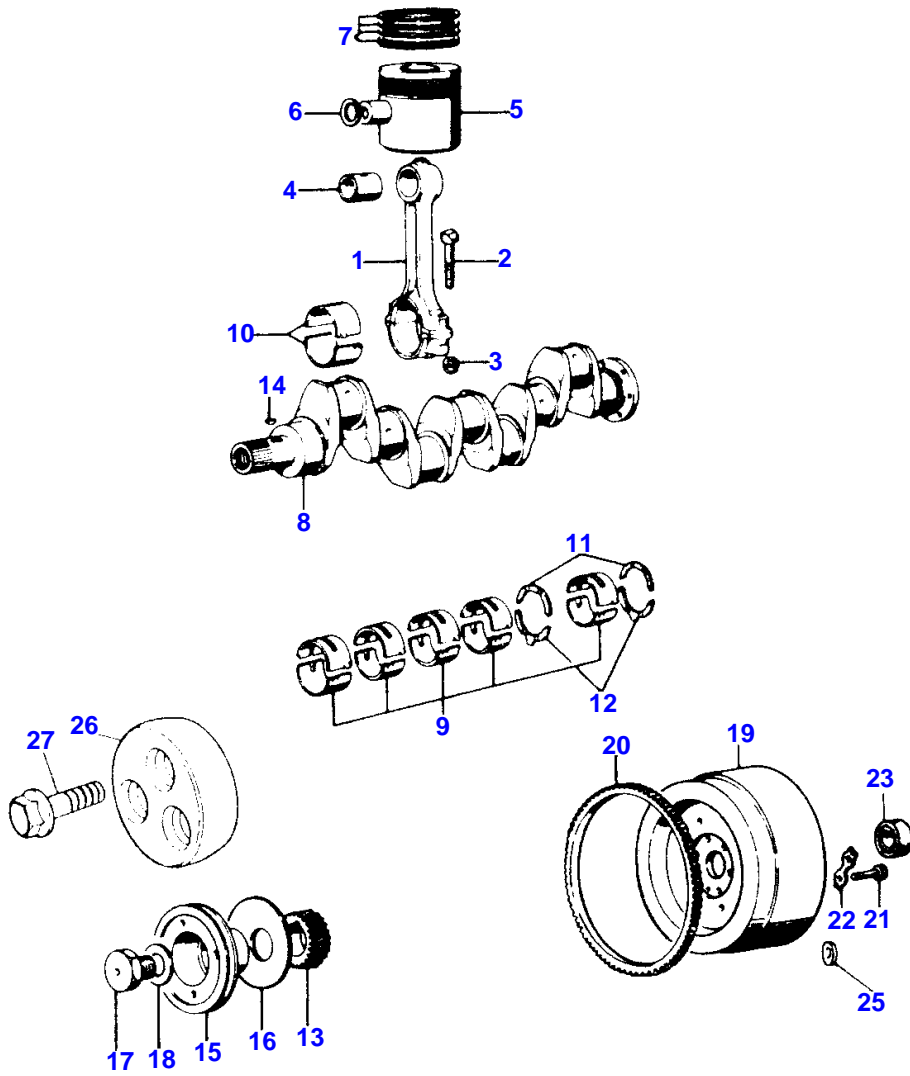

Item	Part Number	Qty	Description	Comments
				A4.248
1	ZZ90009	4	Kit, Conrod	Repairs and replaces M7BJ0015
2	32762116	8	Bolt	
3	33221328	8	Nut	
4	31134123	4	Bush	
5	U5LU0005	4	Kit, Piston	(B)
	89207	4	Kit, Piston	Up to Serial or Engine Number 248U839079J
	U5LP0009	4	Kit, Piston	From Serial or Engine Number 248U839080J
				(C)
6	0170002	8	Circlip	5
7	41158038	4	Kit, Piston Ring	Up to Serial or Engine Number 248U839079J
	41158022	4	Kit, Piston Ring	From Serial or Engine Number 248U839080J
8	U5BG0024	1	Kit, Crankshaft	
9	81558	1	Kit, Bearing	(A)
				8
9	81558A	X	Kit, Bearing	Thickness -0,254MM.
				(A)
9	81558B	X	Kit, Bearing	Thickness -0,508MM.
				(A)
9	81558C	X	Kit, Bearing	Thickness -0,762MM.
				(A)
10	85042	1	Kit, Bearing	(A)
				8
10	85042A	X	Kit, Bearing	Thickness -0,254MM.
				(A)
10	85042B	X	Kit, Bearing	Thickness -0,508MM.
				(A)
10	85042C	X	Kit, Bearing	Thickness -0,762MM.
				(A)
11	31137551	2	Thrust Washer	
				8
11	31137312	X	Thrust Washer	Thickness +0,178MM.
12	31137561	2	Thrust Washer	8
	31137322	X	Thrust Washer	Thickness +0,178MM.
13	31171681	1	Gear	Number of teeth/spines 28
14	0500012	1	Woodruff Key	
15	31148792	1	Pulley	
16	33125416	1	Deflector	
17	32162331	1	Screw	(E)
18	33125124	1	Washer	(E)
19	1825511M1	1	Flywheel	
20	0410236	1	Starter Ring	
21	973013M1	6	Bolt	
22	0921062	3	Tab Washer	
23	339599X1	1	Bearing Ball	
25	33117121	6	Washer	
26	3271R021	1	Spacer	(D)
27	32186139	3	Screw	(D)
				(A)
				PRE-FINISHED
				(B)
				UNTOPPED
				(C)
				PRE-TOPPED
				(D)
				USED ONLY WITH CRANKSHAFTS U5BG0022/U5BG0023/
				(E)
				USED ONLY WITH CRANKSHAFT 68609/94434/U5BG0008/

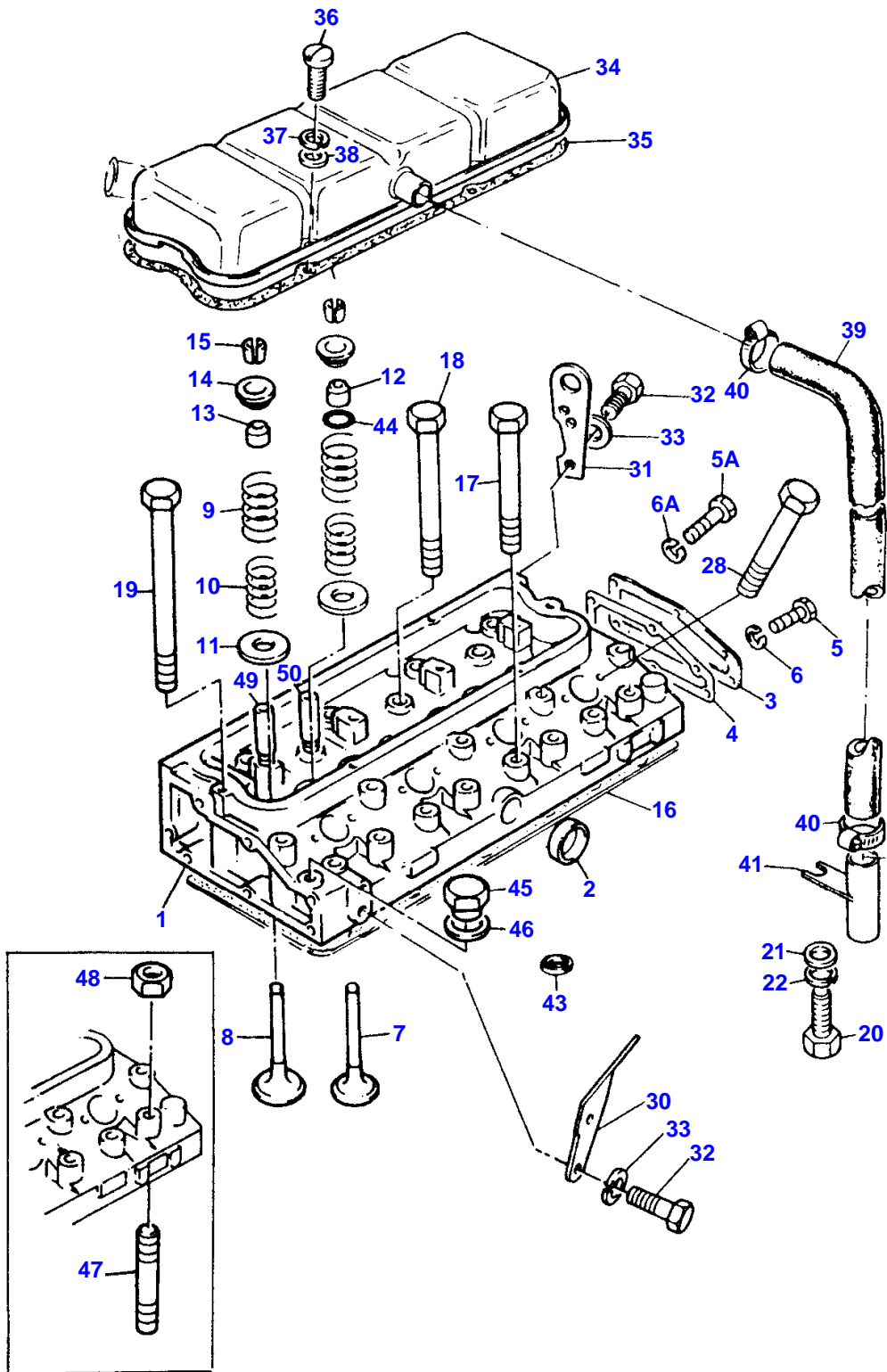

CYLINDER HEAD AND COVER - A4.248

Item	Part Number	Qty	Description	Comments
				A4.248
1	ZZ80015	1	Kit, Cyl. Head	Repairs and replaces A5BD2631
2	0650563	1	Plug	1
3	3621F005	1	Plate	(B) 1
3	3623K007	1	Plate	(C) 1
4	36851409	1	Joint	(B) 1
4	3685R004	1	Joint	(C) 1
5	0746254	6	Setscrew	(B) 1
5	0746254	4	Setscrew	(C) 1
5A	0746452	2	Setscrew	(C) 1
6	0920053	6	Washer	(B) 1
6	0920053	4	Washer	(C) 1
6A	0920054	2	Washer	(C) 1
7	31431641	4	Valve Inlet	1
	31431401	X	Valve Inlet	Thickness +0,076MM. (D)
7	31431402	X	Valve Inlet	Thickness +0,38MM. (D)
7	31431403	X	Valve Inlet	Thickness +0,76MM. (D)
8	31431881	4	Valve Exhaust	1
	31431882	X	Valve Exhaust	Thickness +0,076MM. (D)
8	31431883	X	Valve Exhaust	Thickness +0,038MM. (D)
8	31431884	X	Valve Exhaust	Thickness +0,76MM. (D)
9	31745121	8	Spring	1
10	31744131	8	Spring	1
11	33415118	8	Washer	1
12	33817117	4	Seal	1
13	33817117	4	Seal	1
14	33423147	9	Cap	1
15	33173108	8	Cotter	(A) 1
16	36812349	1	Head Gasket	Up to Serial or Engine Number U08336N
	36812352	1	Head Gasket	From Serial or Engine Number U08337N
17	32181424	8	Screw	
18	32181425	12	Screw	
19	32181426	2	Screw	
20	0096215	1	Screw	
21	0920003	1	Washer	
22	0920053	1	Washer	
28	0096232	8	Bolt	
30	3648C004	1	Plate	Repairs and replaces 36475706
31	36177111	1	Plate	
32	0746453	4	Setscrew	
33	0920054	4	Washer	
34	37188549	1	Cyl.Head Cover	
35	36811132	1	Joint	
36	2172513	4	Screw	
37	0920052	4	Washer	
38	0920002	4	Washer	
39	33872516	1	Pipe	
40	0180063	2	Clip	
41	35731144	1	Union	
43	33152139	X	Insert	
44	2415B201	8	O Ring	1
45	0650203	1	Plug	1

CYLINDER HEAD AND COVER - A4.248

Item	Part Number	Qty	Description	Comments
46	2411157	1	Washer	1
47	32526312	2	Stud	Up to Serial or Engine Number U874811J
48	33221316	2	Nut	Up to Serial or Engine Number U874811J
49	3343F002	4	Guide	(E) 1
50	3343J002	4	Guide	(E) 1 (A) SERVICED IN PAIR (B) USED ON CYLINDER HEADS WITH FIXING HOLES 6 OFF 5/16" (C) USED ON CYLINDER HEADS WITH FIXING HOLES 2 OFF 3/8 " AND 4 OFF 5/16". (D) OVERSIZE VALVES CAN ONLY BE USED WITH CYLINDER HEADS WHEN VALVE GUIDES ARE NOT FITTED. (E) USED ONLY WITH HEADS MACHINED TO ACCOMMODATE VALVE GUIDES

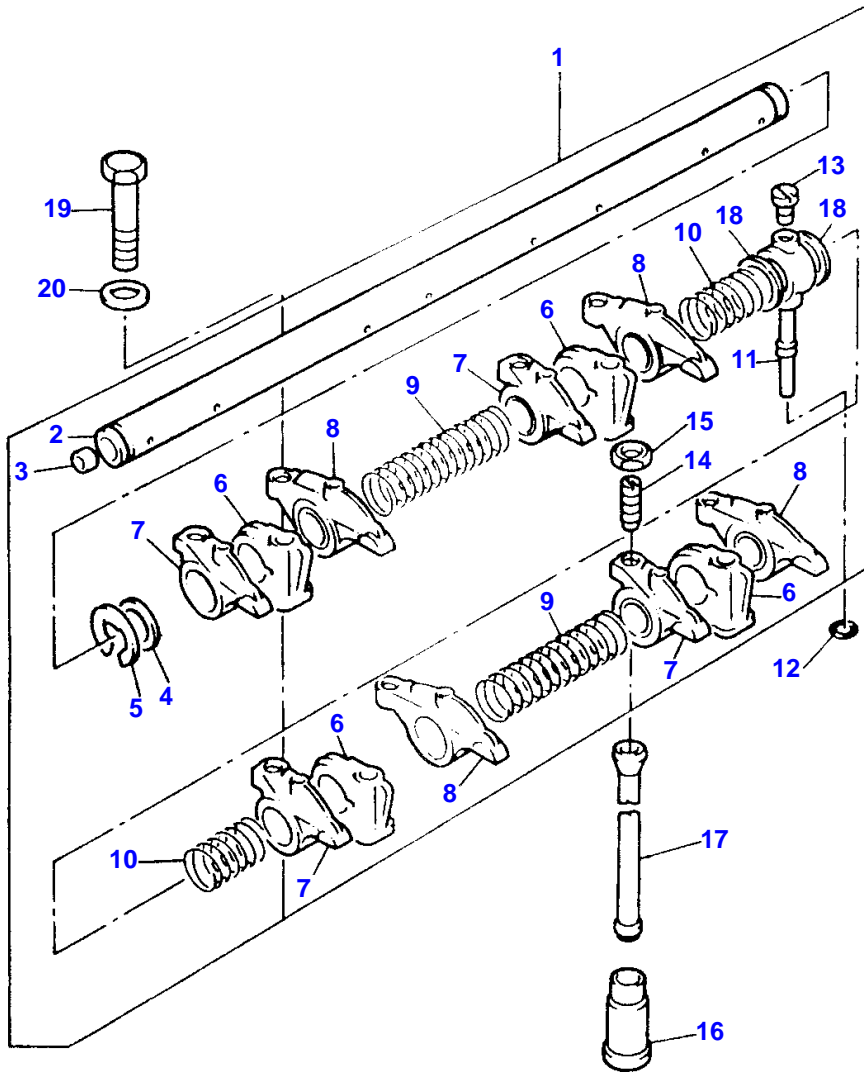

ROCKER ARM - A4.248

Item	Part Number	Qty	Description	Comments
				A4.248
1	ZZ90030	1	Rocker Shaft Ass	
2	ZZ90032	1	Rocker Shaft	1
3	0650507	2	Plug	2
4	33117415	2	Washer	1
5	0170151	2	Circlip	1
6	37521331	4	Bracket	1
7	37371271	4	Rockerarm	Left Hand 1
8	37371281	4	Rockerarm	Right Hand 1
9	31744123	2	Spring	1
10	31743108	2	Spring	1
11	35511111	1	Pipe	1
12	33811113	1	Seal	1
13	0726504	1	Setscrew	1
14	0720579	8	Screw	1
15	0576052	8	Nut	1
16	31434163	8	Tappet	
17	31434307	8	Pushrod	
18	33117426	2	Shim	1
19	0096634	4	Screw	
20	0920006	4	Washer	

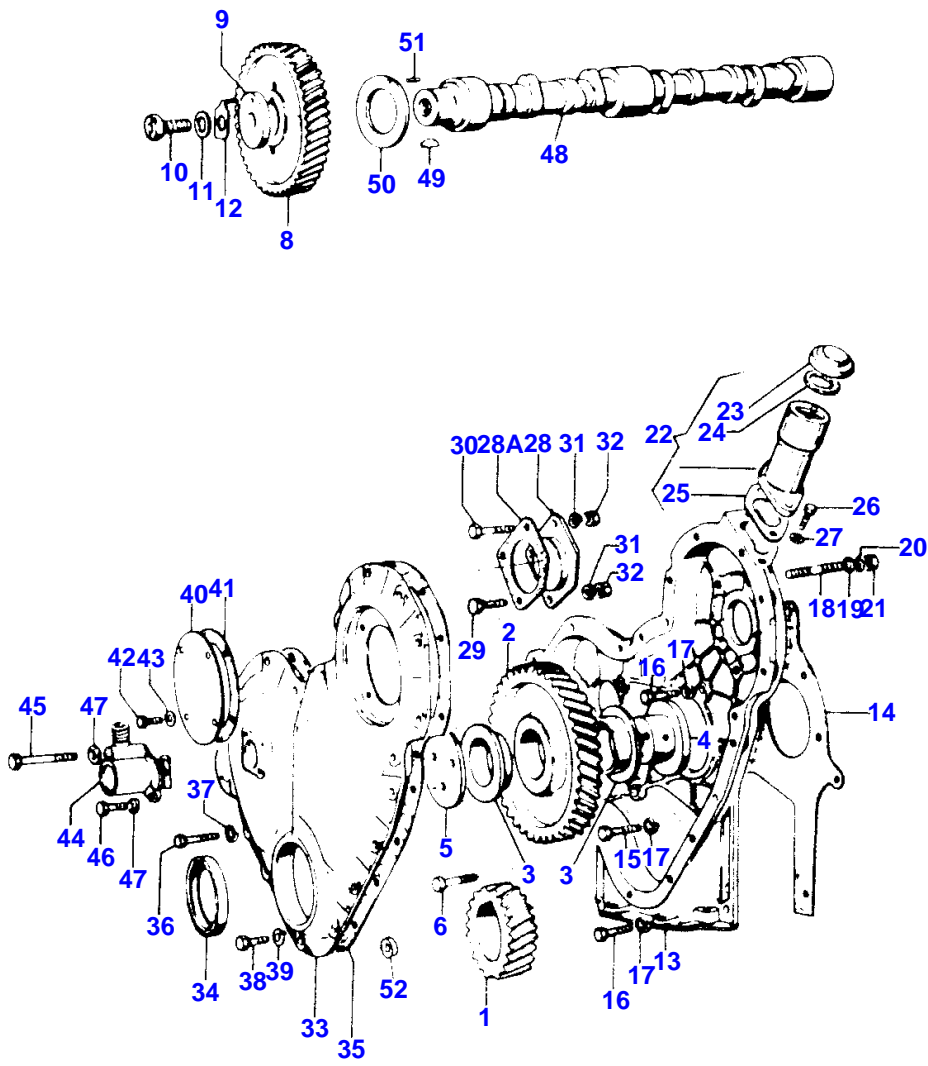

Item	Part Number	Qty	Description	Comments
				A4.248
1	31171681	1	Gear	Number of teeth/spines 28
2	41115023	1	Gear	Number of teeth/spines 63
3	0050345	2	Bush	2
4	33426161	1	Hub	
5	0941082	1	Washer	
6	0096439	3	Bolt	Up to Serial or Engine Number U08336N
	2184634	3	Screw	From Serial or Engine Number U08337N
8	31171353	1	Gear	Up to Serial or Engine Number U08336N
				Number of teeth/spines 56
8	3117L011	1	Gear	From Serial or Engine Number U08337N
				Number of teeth/spines 56
9	33153128	1	Washer	
10	32161209	1	Screw	
11	33115408	1	Washer	
12	31733121	1	Washer	
13	37161642	1	Housing	
14	36814127	1	Joint	Up to Serial or Engine Number U08336N
	36814137	1	Joint	From Serial or Engine Number U08337N
15	0746211	1	Bolt	
16	2183205	8	Screw	
17	0920053	9	Washer	
18	2217138	3	Stud	Repairs and replaces 0826277
19	0920003	3	Washer	
20	0920053	3	Washer	
21	0576002	3	Nut	
22	35784119	1	Banjo Bolt	
23	2487854	1	Cap	22
24	24870001	1	Joint	23
25	36862138	1	Joint	
26	0746254	2	Setscrew	
27	2411152	2	Washer	
28	37556148	1	Plate	
28A	36861429	1	Joint	
29	0748505	1	Screw	
30	2232151	2	Screw	
31	0920054	3	Washer	
32	2238153	3	Nut	
33	37166401	1	Cover	Repairs and replaces 41422703
34	2418F436	1	Seal	33
35	36813137	1	Joint	
36	0746255	14	Setscrew	Up to Serial or Engine Number
	2183205	10	Screw	From Serial or Engine Number
37	0920053	14	Washer	Up to Serial or Engine Number
	0920053	10	Washer	From Serial or Engine Number
38	0096238	4	Bolt	
39	2411152	4	Gasket	
40	3241H004	1	Plate	
41	33825419	1	Joint	
42	0746252	4	Screw	Up to Serial or Engine Number
	2183203	4	Screw	From Serial or Engine Number
43	2411152	4	Washer	Up to Serial or Engine Number
	0920053	4	Washer	From Serial or Engine Number
44	2758346	1	Angle Drive	
45	0746019	1	Screw	
46	0746053	1	Bolt	
47	2411151	2	Gasket	
48	31415321	1	Camshaft	Up to Serial or Engine Number U08336N
	31415371	1	Camshaft	From Serial or Engine Number U08337N
49	0500012	1	Woodruff Key	
50	33153121	1	Washer	
51	2116053	1	Pin	

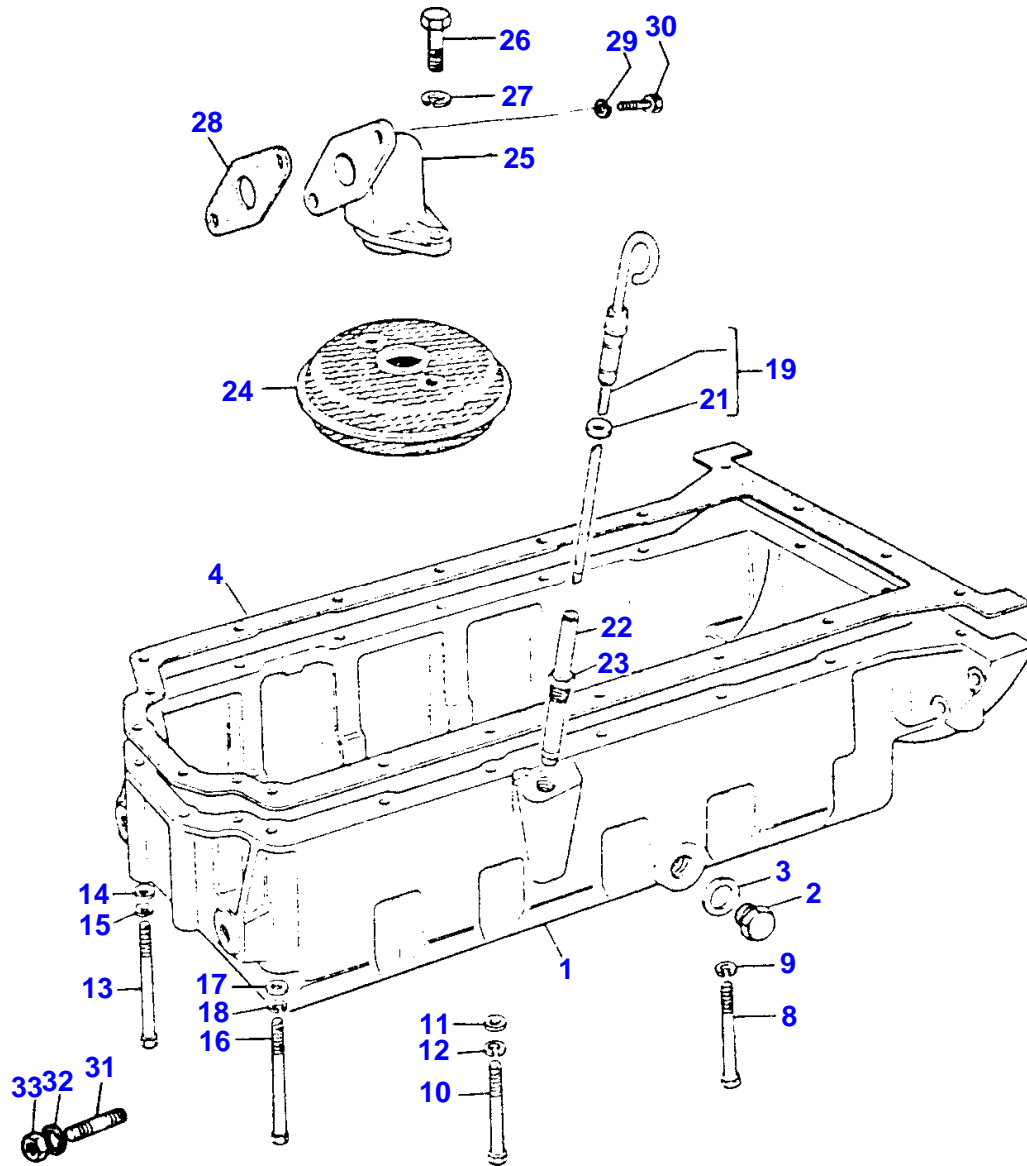

Buy Now



Our support email:

ebooklibonline@outlook.com