

Page Title	Page Number
CYLINDER BLOCK - A4.236	2
CRANKSHAFT & FLYWHEEL - A4.236	4
CYLINDER HEAD AND COVER - A4.236	6
ROCKER ARM - A4.236	8
TIMING GEAR - A4.236	10
LUBRICATING OIL SUMP - A4.236	12
OIL SUMP - A4.236	14
BALANCER UNIT - A4.236	16
BALANCER UNIT - A4.236	18
BALANCER UNIT - A4.236	20
LUBRICATING OIL FILTER - A4.236	22
WATER PUMP AND FAN - A4.236	24
FUEL PIPINGS - A4.236	28
FUEL FILTER - A4.236	32
LIFT PUMP - A4.236	34
STARTER MOTOR	36
STARTER MOTOR - LUCAS	37A
ALTERNATOR	38
GASKET SET - A4.236	40
ENGINE - A4.236	42
FUEL PIPINGS	44
FUEL PIPINGS	46
FUEL TANK	48
FUEL TANK	50
FUEL TANK	52
RADIATOR	54
INDUCTION MANIFOLD AND AIR FILTER	56
EXHAUST MANIFOLD AND MUFFLER - MUFFLER HORIZONTAL	58
EXHAUST MANIFOLD AND MUFFLER - MUFFLER VERTICAL	60
ENGINE CONTROLS	62
ELECTRICAL EQUIPMENT	64
ELECTRICAL WIRING	66
BATTERY	68
LIGHTS	70
LIGHTS	72
INSTRUMENT PANEL	74
DUAL CLUTCH - LUK	76
DUAL CLUTCH - LUK	78
DUAL CLUTCH - O.M.G.	80
DUAL CLUTCH - O.M.G.	82
CLUTCH CONTROL	84
CENTRE AXLE HOUSING AND TRANSMISSION HOUSING	88
SYNCHRO-MESH TRANSMISSION	92
REDUCER	96
CONTROLS AND TRANSMISSION LEVERS	98
REDUCER CONTROL	102
POWER TAKE OFF - STD	104
POWER TAKE OFF - 540/1000 R.P.M.	106
DIFFERENTIAL	108
REAR AXLE-HOUSING	110
DIFFERENTIAL LOCK CONTROLS	112
DIFFERENTIAL LOCK	114
BRAKING CONTROL	116
DRY BRAKES	118
WET BRAKES	120
HAND BRAKE	122
HAND BRAKE	124
BRAKE PUMP	128
BRAKE CYLINDER	130
HYDRAULIQUE TRAILER BRACKING SYSTEM	132
RIM & TIRES	134
FRONT AXLE - 2 WHEEL DRIVE	138
STEERING HYDRAULIC EQUIPMENT	140
STEERING CONTROL VALVE	144
STEERING CONTROL VALVE - 2 WHEEL DRIVE	146
STEERING CONTROL VALVE - 4 WHEEL DRIVE	148

TABLE OF CONTENT

STEERING CONTROL VALVE - 4 WHEEL DRIVE	150
STEERING PUMP	152
STEERING CYLINDER - 2 WHEEL DRIVE	154
STEERING CYLINDER - 4 WHEEL DRIVE	156
STEERING CYLINDER - 4 WHEEL DRIVE	158
HYDRAULIC LIFT PIPINGS	160
OIL PUMP - HYDRAULIC LIFT	164
HYDRAULIC CONTROL VALVE - HYDRAULIC LIFT	166
HYDRAULIC CONTROL VALVE - HYDRAULIC LIFT	168
HYDRAULIC LIFT	170
LIFT CONTROL	174
LIFT CONTROL	178
PIPINGS AUXILIARY CONTROL VALVES	182
PIPINGS AUXILIARY CONTROL VALVES	184
PIPINGS AUXILIARY CONTROL VALVES	186
ADDITIONAL POWER OUTLET UNIT	188
AUXILIARY HYDRAULIC VALVES	190
AUXILIARY HYDRAULICS VALVE - STD	192
AUXILIARY HYDRAULICS VALVE - STD	194
AUXILIARY HYDRAULIC VALVES - FLOATING	196
AUXILIARY HYDRAULIC VALVES - FLOATING	198
VALVE - HYDRAULICS EQUIPMENT	200
VALVE - HYDRAULICS EQUIPMENT	202
LINKAGE	204
LINKAGE	208
LINKAGE	212
REAR HOOK	216
DRAWBAR	218
REAR HOOK	220
REAR HOOK	222
REAR HOOK	224
HOOK AND FRONT WEIGHTS	226
HOOK AND FRONT WEIGHTS	228
HARDNOSE AND GRILLES	230
ENGINE HOOD	232
HOOD BRACKET AND INSTRUMENT PANEL	234
FENDERS AND PLATFORM	236
FENDERS AND PLATFORM	238
FRONT FENDERS	242
FRONT FENDERS	244
SEAT	246
SEAT	248
SEAT	250
SAFETY FRAME	252
DECALS AND EMBLEMS	254
TRANSFER GEAR BOX - 4 WHEEL DRIVE	256
TRANSFER GEAR BOX - 4 WHEEL DRIVE	258
FRONT AXLE - HOUSING - DIFFERENTIAL	260
FRONT AXLE - FINAL DRIVE	264
TOOL GROUP	268

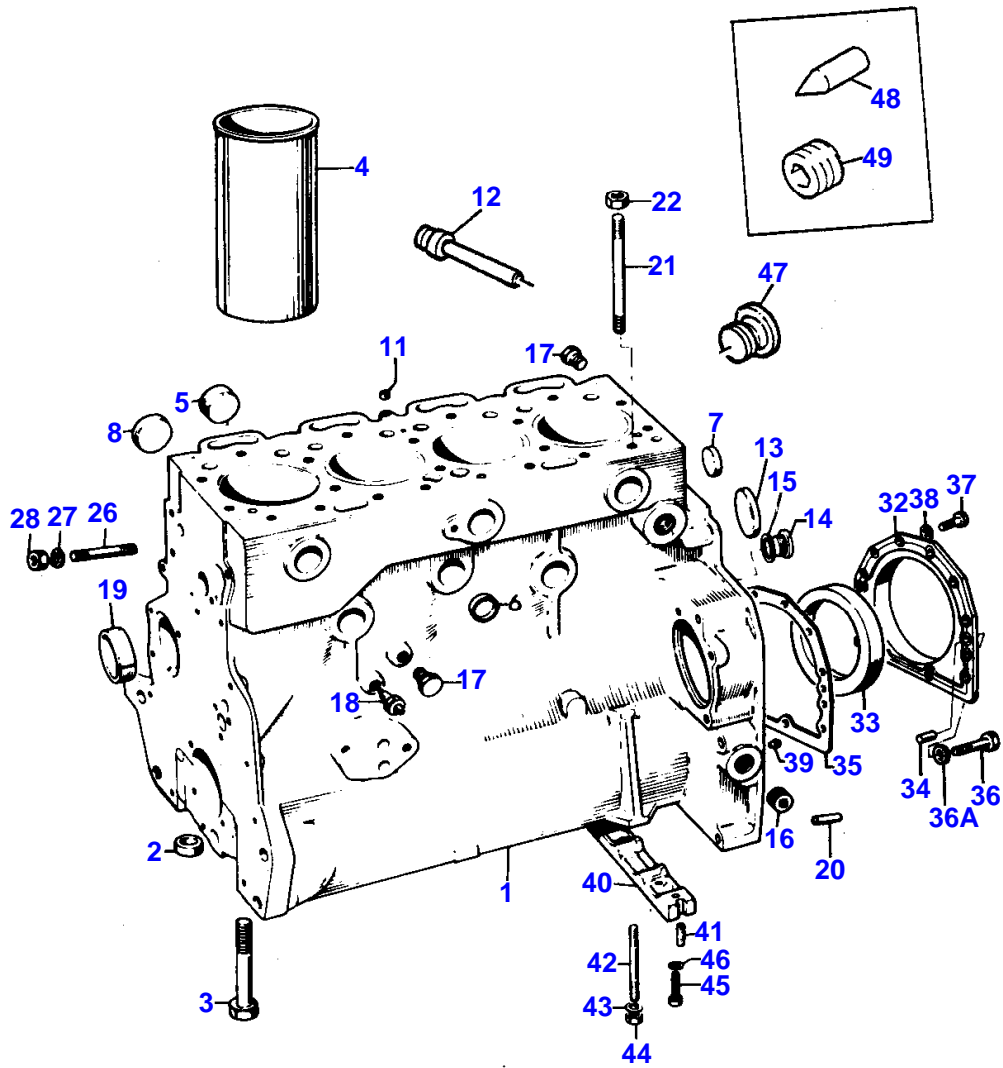

MASSEY FERGUSON

MF 184 S TRACTOR - 3310472

3310472

CYLINDER BLOCK - A4.236

2

Item	Part Number	Qty	Description	Comments
				A4.236
1	ZZ50031	1	Kit,Cyl.Block	Up to Serial or Engine Number
	ZZ50114	1	Kit,Cyl.Block	From Serial or Engine Number
2	33142111	10	Thimble	1
3	32166329	10	Bolt	1
4	31358394	X	Liner	(B) Up to Serial or Engine Number U08336N
				1
4	3135X032	X	Liner	(B) From Serial or Engine Number U08337N
				1
4	31358393	4	Liner	(A) Up to Serial or Engine Number U08336N
				1
4	3135X031	4	Liner	(A) From Serial or Engine Number U08337N
				1
5	0650618	4	Plug	1
6	0650563	6	Plug	1
7	0650563	2	Plug	1
8	0650577	4	Plug	
11	32417134	1	Plug	
12	2485A204	1	Plug	
13	32416105	1	Plug	
14	0650582	1	Plug	
15	0920130	1	Washer	
16	0650588	1	Plug	
17	2431131	1	Plug	
18	1423895M91	1	Switch	Up to Serial or Engine Number 131G00103/231E00411
	1877721M92	1	Pressure Switch	From Serial or Engine Number 131G00104/231E00412
19	31134132	1	Bush	
20	0350018	2	Dowel	
26	0826469	1	Stud	
27	0920054	1	Washer	
28	0576051	1	Nut	
32	4142V031	1	Housing	
33	2418F475	1	Seal	32
34	0350009	2	Dowel	
35	36817157	1	Joint	
36	2172530	2	Capscrew	
36A	33112111	2	Washer	
37	0746211	10	Bolt	
38	0920003	10	Washer	
39	32452113	1	Pointer	
40	36277833	1	Bridge Piece	
41	32811408	1	Joint	
42	2217150	2	Stud	
43	0920521	2	Washer	
44	0576002	2	Nut	
45	2176369	2	Screw	
46	0920521	2	Washer	
47	32161114	2	Plug	
48	32452113	1	Pointer	
49	0650588	1	Plug	

(A)
PRESS FITTING
(B)
SLIP FIT

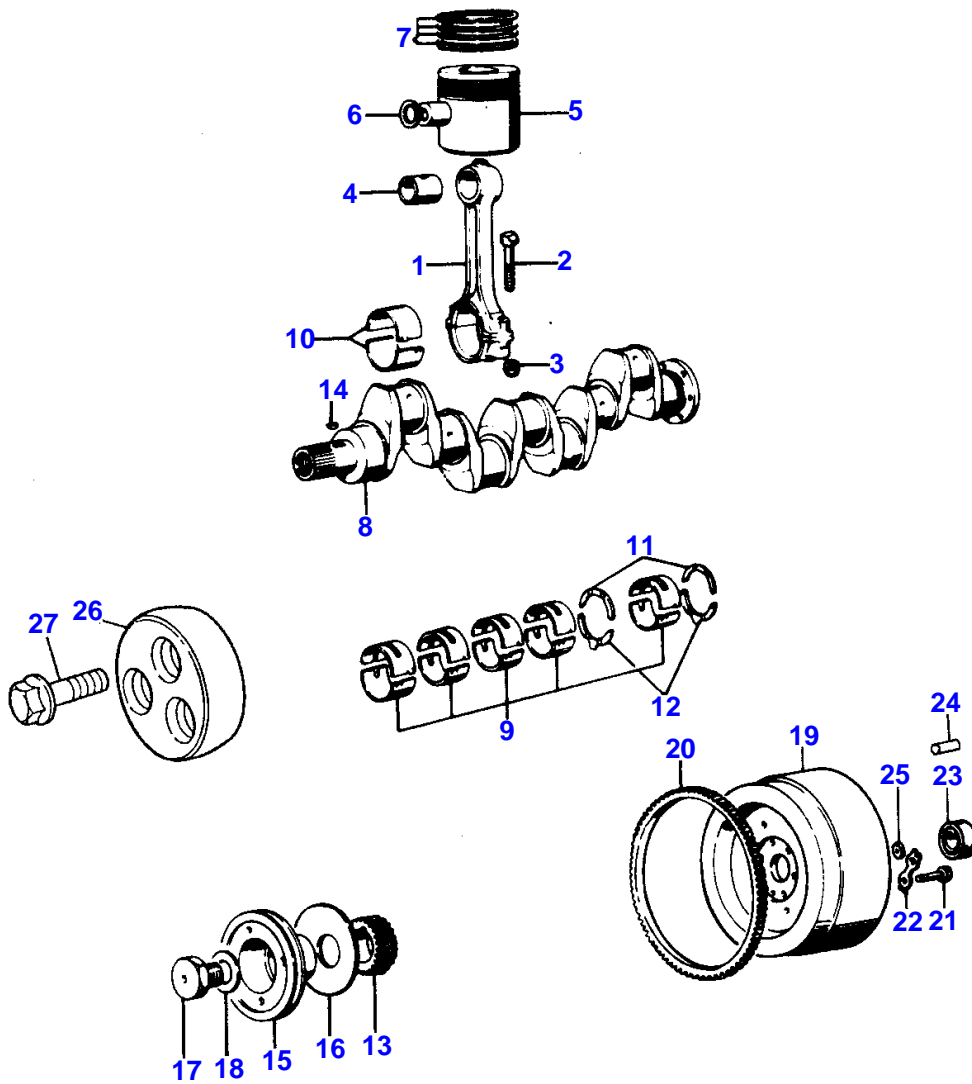

Item	Part Number	Qty	Description	Comments
				A4.236
1	ZZ90009	4	Kit, Conrod	Repairs and replaces M7BJ0015
2	32762116	8	Bolt	1
3	33221328	8	Nut	1
4	31134123	4	Bush	1
5	68301	4	Kit, Piston	(D)
	68300	X	Kit, Piston	(A)
	68301C	X	Kit, Piston	(D)
				Thickness +0,762MM.
5	68300C	X	Kit, Piston	(A)
				Thickness +0,762MM.
6	0170002	8	Circlip	5
7	41158041	4	Kit, Piston Ring	
	41158041C	X	Kit, Piston Ring	(D)
				Thickness +0,762MM.
8		1	Crankshaft	Not serviced, order 68609
9	81558	1	Kit, Bearing	(C)
				8
9	81558A	X	Kit, Bearing	(C)
				Thickness -0,254MM.
9	81558B	X	Kit, Bearing	(C)
				Thickness -0,508MM.
9	81558C	X	Kit, Bearing	(C)
				Thickness -0,762MM.
10	85042	1	Kit, Bearing	(C)
				8
10	85042A	X	Kit, Bearing	(C)
				Thickness -0,254MM.
10	85042B	X	Kit, Bearing	(C)
				Thickness -0,508MM.
10	85042C	X	Kit, Bearing	(C)
				Thickness -0,762MM.
11	31137311	2	Washer	8
	31137312	X	Thrust Washer	Thickness +0,178MM.
12	31137321	2	Washer	8
	31137322	X	Thrust Washer	Thickness +0,178MM.
13	31171681	1	Gear,Crankshaft	Number of teeth/spines 28
14	0500012	1	Woodruff Key	
15	31148792	1	Pulley	
16	33125416	1	Washer	
17	32162331	1	Screw	
18	33125124	1	Washer	
19	1825511M1	1	Flywheel	
20	0410236	1	Starter Ring	
21	973013M1	6	Bolt	
22	0921062	3	Tab Washer	
23	339599X1	1	Bearing Ball	
24	1817069M1	2	Pin	(B)
25	33117121	6	Washer	
26	3271R021	1	Spacer	(E)
27	32186139	3	Screw	(E)
				(A)
				SEMIFINISHED
				(B)
				USED ONLY FOR SINGLE CLUTCH
				(C)
				PRE-FINISHED
				(D)
				PRE-TOPPED
				(E)
				USED ONLY WITH CRANKSHAFTS U5BG0022/U5BG0023/U5BG0024/U5BG0025/U5BG0026

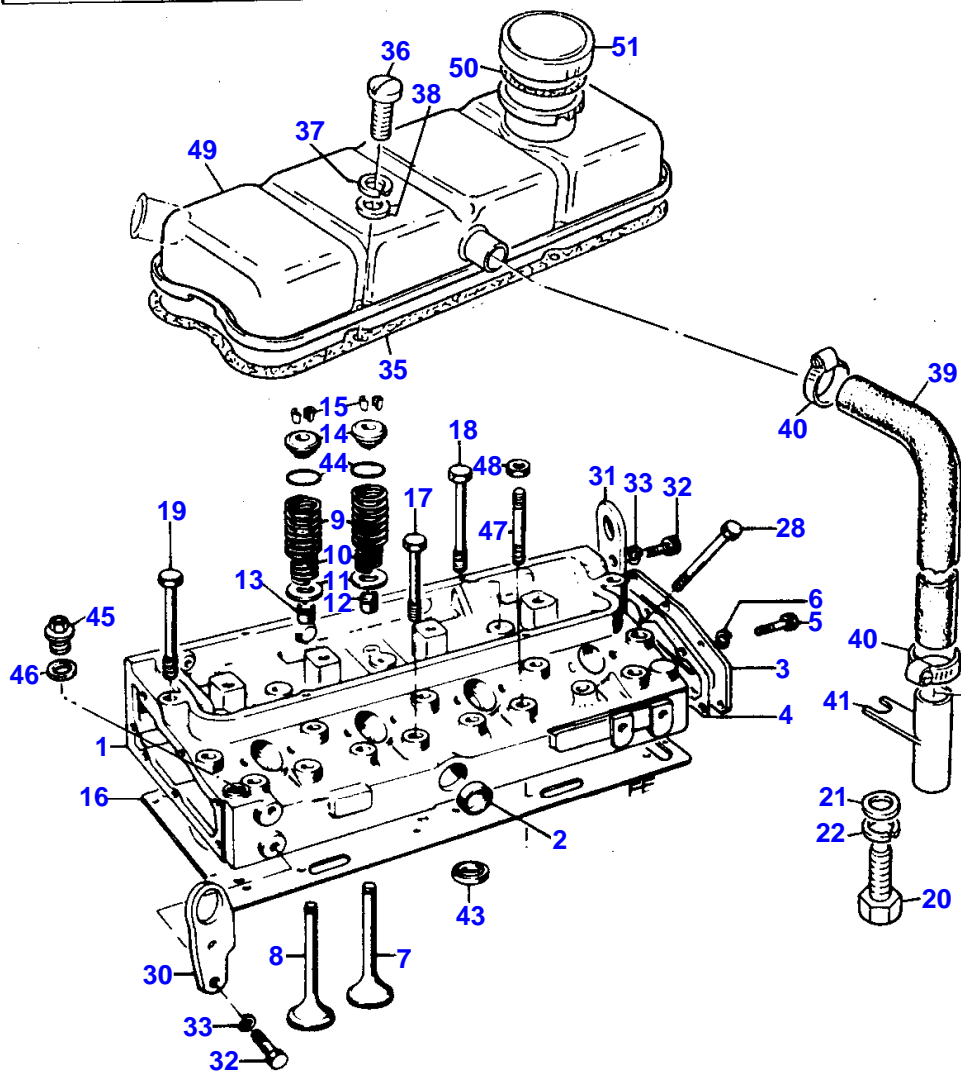
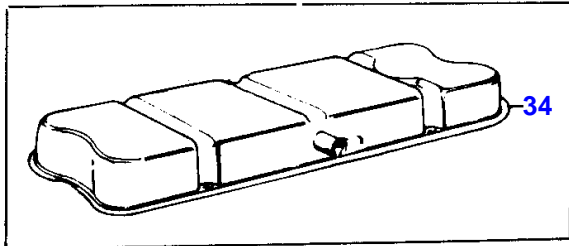

CYLINDER HEAD AND COVER - A4.236

Item	Part Number	Qty	Description	Comments
				A4.236
1	ZZ80054	1	Kit, Cyl. Head	
2	0650563	1	Plug	1
3	3621F005	1	Plate	1
4	36851409	1	Joint	1
5	0746254	6	Setscrew	1
6	0920053	6	Washer	1
7	31431641	4	Valve Inlet	1
	31431401	X	Valve Inlet	Thickness +0,076MM.
	31431402	X	Valve Inlet	Thickness +0,38MM.
	31431403	X	Valve Inlet	Thickness +0,76MM.
8	31431881	4	Valve Exhaust	1
	31431882	X	Valve Exhaust	Thickness +0,076MM.
	31431883	X	Valve Exhaust	Thickness +0,38MM.
	31431884	X	Valve Exhaust	Thickness +0,76MM.
9	31745121	8	Spring	1
10	31744131	8	Spring	1
11	33415118	8	Washer	1
12	33817117	4	Seal	1
13	33817117	4	Seal	1
14	33423147	9	Cap	1
15	33173108	8	Cotter	(A) 1
16	36812349	1	Head Gasket	Up to Serial or Engine Number U08336N
	36812352	1	Head Gasket	From Serial or Engine Number U08337N
17	32181424	8	Screw	
18	32181425	12	Screw	
19	32181426	2	Screw	
20	0096215	1	Screw	
21	0920003	1	Washer	
22	0920053	1	Washer	
25	2217202	1	Stud	
26	0920054	1	Washer	
27	0576051	1	Nut	
28	0096232	8	Bolt	
30	3648C004	1	Plate	
31	36177111	1	Plate	
32	0746453	4	Setscrew	
33	0920054	4	Washer	
34	37188549	1	Cyl.Head Cover	Up to Serial or Engine Number
35	36811132	1	Joint	
36	2172513	4	Screw	
37	0920052	4	Washer	
38	0920002	4	Washer	
39	33872516	1	Pipe,Breather	
40	0180063	2	Clip	
41	35731144	1	Pipe,Breather	
43	33152139	X	Insert	
44	24158201	8	O Ring	1
45	0650203	1	Plug	1
46	2411107	1	Washer	1
47	32526312	2	Stud	Up to Serial or Engine Number U874811J
48	33221316	2	Nut	Up to Serial or Engine Number U874811J
49	37188141	1	Cyl.Head Cover	From Serial or Engine Number
50	24870002	1	Joint	From Serial or Engine Number 51
51	2487845	1	Cap	From Serial or Engine Number (A) SERVICED IN PAIR

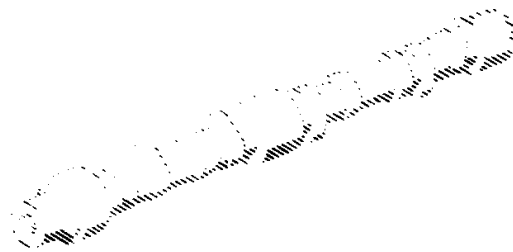
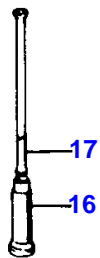
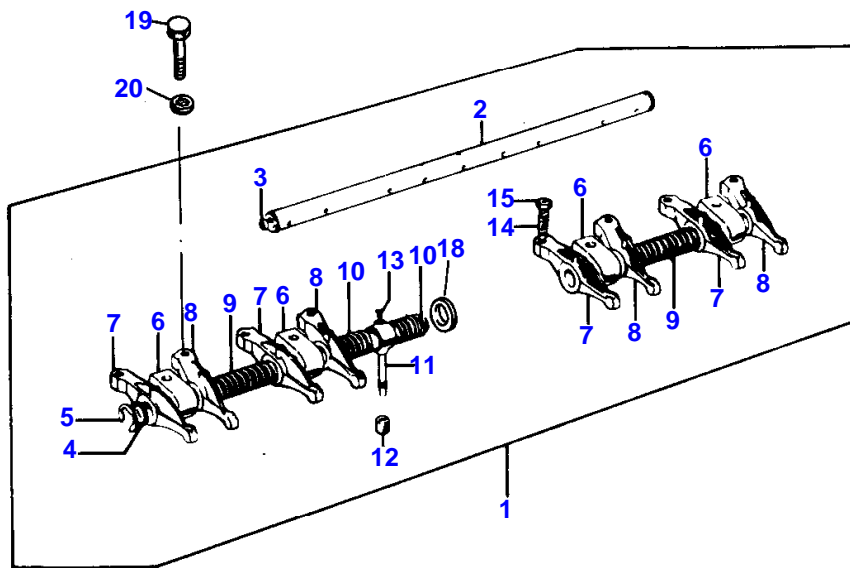

ROCKER ARM - A4.236

Item	Part Number	Qty	Description	Comments
				A4.236
1	ZZ90030	1	Rocker Shaft Ass	
2	ZZ90032	1	Rocker Shaft	1
3	0650507	2	Plug	2
4	33117434	2	Washer	1
5	0170151	2	Circlip	1
6	37521332	4	Bracket	1
7	37371271	4	Lever	Left Hand 1
8	37371281	4	Lever	Right Hand 1
9	31744123	2	Spring	1
10	31743108	2	Spring	1
11	3775E011	1	Connection	1
12	33811113	1	Olive	
13	2231236	1	Setscrew	1
14	0720579	8	Screw	1
15	0576052	8	Nut	1
16	31434163	8	Tappet	
17	31434307	8	Pushrod	
18	33117426	2	Shim	1
19	0096634	4	Screw	
20	0920006	4	Washer	

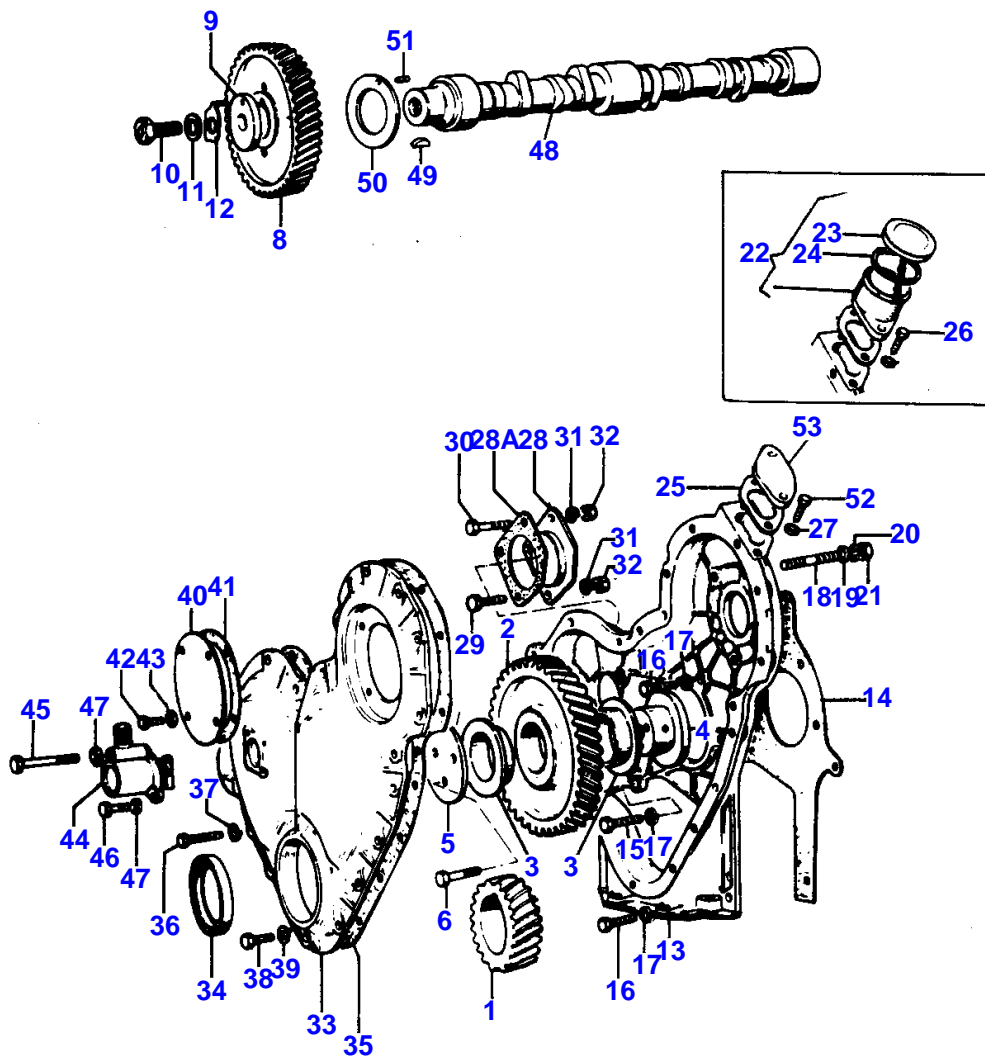

TIMING GEAR - A4.236

Item	Part Number	Qty	Description	Comments
				A4.236
1	31171681	1	Gear	Number of teeth/spines 28
2	41115023	1	Idler	Number of teeth/spines 63
3	0050345	2	Bush	2
4	33426161	1	Hub	
5	0941082	1	Plate	
6	0096439	3	Bolt	Up to Serial or Engine Number U08336N
	2184634	3	Screw	From Serial or Engine Number U08337N
8	31171353	1	Gear	Number of teeth/spines 56
				Up to Serial or Engine Number U08336N
8	3117L011	1	Gear	From Serial or Engine Number U08337N
9	33153128		Washer	
10	32161217	1	Screw	
11	33115408	1	Washer	
12	31733121	1	Washer	
13	37161642	1	Housing	
14	36814127	1	Joint	Up to Serial or Engine Number U08336N
	36814137	1	Joint	From Serial or Engine Number U08337N
15	0746211	1	Bolt	
16	0746255	8	Setscrew	
17	0920053	9	Washer	
18	2217104	3	Stud	
19	0920003	3	Washer	
20	0920053	3	Washer	
21	0576002	3	Nut	
22	35784119	1	Filler	Up to Serial or Engine Number
23		1	Plug	Up to Serial or Engine Number 22
24		1	Gasket	Up to Serial or Engine Number 23
25	36862138	1	Joint	
26	2183204	2	Screw	Up to Serial or Engine Number
27	0920053	2	Washer	
28	37556148	1	Plate	
28A	36861429	1	Joint	
29	0748505	1	Screw	
30	2232151	2	Screw	
31	0920054	3	Washer	
32	2238153	3	Nut	
33	37166401	1	Cover	
34	2418F436	1	Seal	33
35	36813137	1	Joint	
36	2183205	14	Screw	
37	0920053	14	Washer	
38	0096238	4	Bolt	
39	2411152	4	Washer	
40	3241H004	1	Plate	
41	33825419	1	Joint	
42	2183203	4	Screw	
43	0920053	4	Washer	
44	2758346	1	Angle Drive	
45	2186106	1	Screw	
46	2183104	1	Screw	
47	0920052	2	Washer	
48	31415321	1	Camshaft	Up to Serial or Engine Number U08336N
	31415371	1	Camshaft	From Serial or Engine Number U08337N
49	0500012	1	Woodruff Key	
50	33153121	1	Washer	
51	2116053	1	Pin	
52	2183203	2	Screw	
53	36235118	1	Plate	

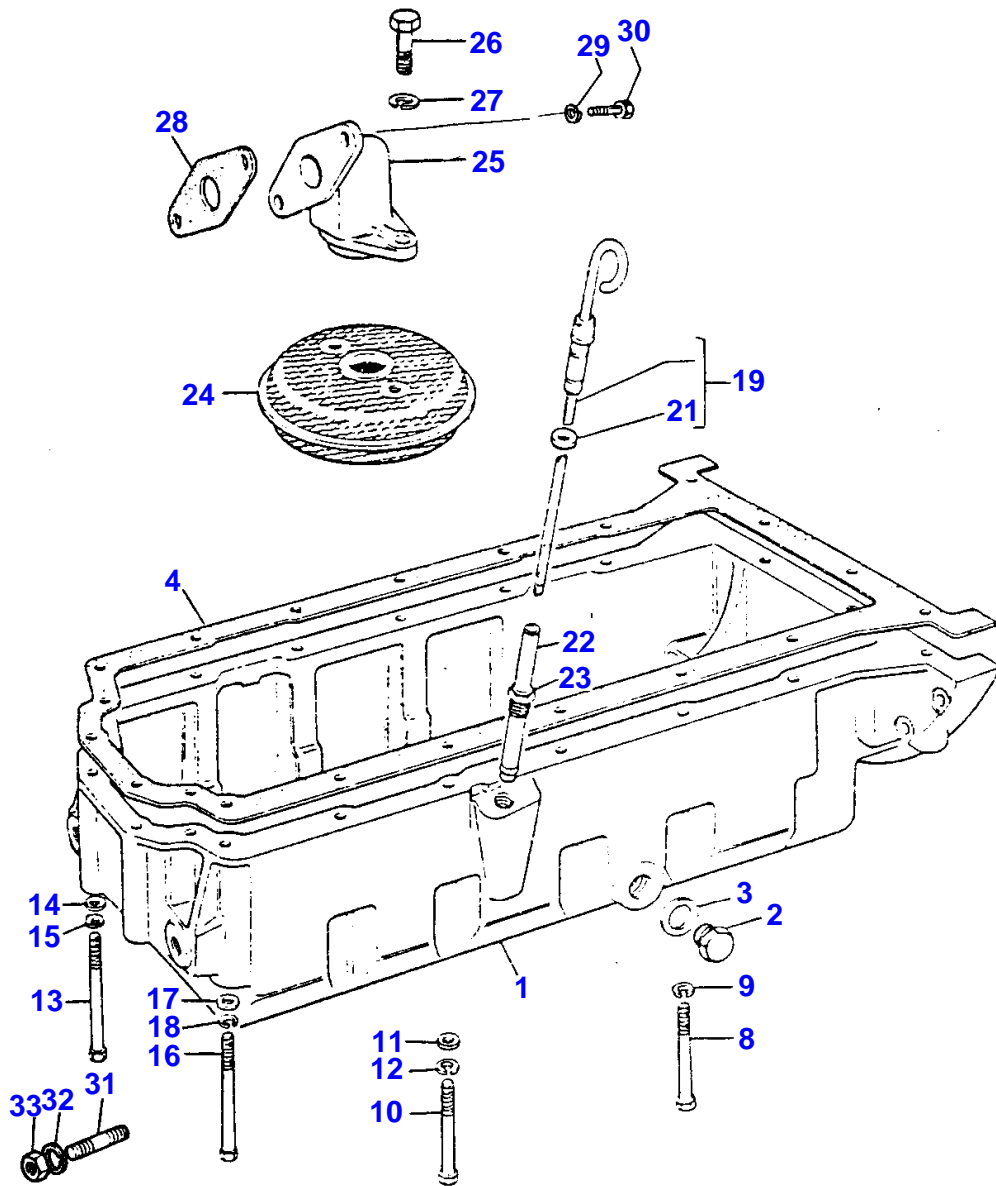

MASSEY FERGUSON**MF 184 S TRACTOR - 3310472****3310472****LUBRICATING OIL SUMP - A4.236****12**

Item	Part Number	Qty	Description	Comments
				A4.236 Up to Serial or Engine Number U923014K
1	37171825	1	Sump	
2	2487004	1	Plug	
3	2411260	1	Washer	
4	36815721	1	Joint	
8	0096241	11	Bolt	
9	0920053	11	Washer	
10	0096215	1	Screw	
11	0920003	1	Washer	
12	0920053	1	Washer	
13	2184435	4	Screw	
14	0920003	4	Washer	
15	0920053	4	Washer	
16	2184435	2	Screw	
17	0920003	2	Washer	
18	0920053	2	Washer	
19	31787437	1	Dipstick	
21	33812108	1	Washer	19
22	33435123	1	Tube	
23	33533103	1	Nut	
24	37725443	1	Strainer	
25	37738261	1	Elbow	
26	0746052	2	Bolt	
27	0920052	2	Washer	
28	36832409	1	Joint	
29	0920053	2	Washer	
30	0096237	2	Bolt	
31	974496M1	4	Bolt	
32	391414X1	6	Washer	
33	393643X1	6	Nut Metric	

Buy Now



Our support email:

ebooklibonline@outlook.com