

Page Title	Page Number
ENGINE - D3.152 ENGINE	1
CYLINDER BLOCK - D3.152 ENGINE	2
CRANKSHAFT, PISTONS AND CONNECTING RODS - D3.152 ENGINE	3
CYLINDER HEAD - D3.152 ENGINE	4
ROCKER SHAFT - D3.152 ENGINE	5
TIMING GEAR AND CAMSHAFT - D3.152 ENGINE	6
FUEL INJECTION EQUIPMENT (DIESEL) - D3.152 ENGINE	7
LUBRICATING OIL SUMP - D3.152 ENGINE	8
LUBRICATING OIL FILTER AND INTEGRAL COOLER - D3.152 ENGINE	9
WATER PUMP, THERMOSTAT AND HEAT EXCHANGER - D3.152 ENGINE	10
LOW PRESSURE FUEL SYSTEM - D3.152 ENGINE	11
AIR INDUCTION AND EXHAUST SYSTEM - D3.152 ENGINE	12
ALTERNATOR POSITIONER - D3.152 ENGINE	13
JOINTS AND GASKETS - D3.152 ENGINE	14
ALTERNATOR - VALEO TYPE	15
ALTERNATOR-LUCAS	16
STARTER MOTOR	17
COOLING SYSTEM-ENGINE - FAN AND HOSES	18
COOLING SYSTEM - RADIATOR AND BRACKET	19
FUEL SYSTEM-FUEL FILTER	20
FUEL SYSTEM-FUEL FILTER	21
FUEL SYSTEM-FUEL TANK AND ATTACHMENTS	22
AIR FILTER-OIL BATH AIR FILTER	23
EXHAUST SYSTEM-VERTICAL	24
EXHAUST SYSTEM-VERTICAL	25
THROTTLE CONTROLS	26
ELECTRICAL WIRING	27
BATTERY	28
INSTRUMENT PANEL AND INSTRUMENTS	29
SINGLE CLUTCH - P.&V. - 10	30
SINGLE CLUTCH - B.&B. - 10	31
CLUTCH-DUAL CLUTCH - LUK - 11	32
CLUTCH-DUAL CLUTCH - O.M.G. - 11	33
CLUTCH CONTROL	34
CLUTCH CONTROL	35
CLUTCH CONTROL - CLUTCH SHAFT BRAKING SISTEM	36
CENTRE AXLE HOUSING AND TRANSMISSION HOUSING	37
TRANSMISSION-GEAR TRAIN	38
TRANSMISSION-GEAR TRAIN	39
SHIFT LEVERS-12 SPEED TRANSMISSION	40
PTO SHAFT - STANDARD	41
PTO SHAFT - 540/750/1000 R.P.M.	42
REAR AXLE-HOUSING - FINAL DRIVE	43
BRAKE AND CONTROLS	44
BRAKES-HANDBRAKE	45
STEERING CLUTCH	46
TRACK ADJUSTER	47
TRACK CHAIN - TRACK CHAIN	48
SUSPENSION - FRONT - REAR	49
SUSPENSION - TRACK CARRIER	50
UPPER ROLLER - UPPER TRACK ROLLER	51
LOWER ROLLER	52
HYDRAULIC LIFT PIPINGS	53
HYDRAULIC PUMP - HYDRAULIC LIFT	54
HYDRAULIC LIFT VALVE	55
HYDRAULIC LIFT-LIFT ARMS	56
REAR CONTROLS-DRAFT AND POSITION	57
REAR CONTROLS-DRAFT AND POSITION	58
AUXILIARY HYDRAULIC VALVE LINES	59
AUXILIARY HYDRAULICS VALVE - STANDARD	60
AUXILIARY HYDRAULICS VALVE - FLOATING	61
HYDRAULICS EQUIPMENT-VALVE	62
LIFT HITCH - WITH THREE POINT LINKAGE CAT 1	63
LINKAGE CAT 2	64
HOOD AND GRILLE	65
SHEET METAL-PANELS - BRACKETS AND ASSEMBLING PARTS	66

TABLE OF CONTENT

00

DECALS	67
FENDERS AND PLATFORM	68
GUARDS - TRACK ROLLERS GUARDS	69
SAFETY FRAME	70
SEAT-SABLE - STANDARD	71
SEAT-SABLE - LUX TYPE	72
LIGHTING EQUIPMENT	73
WEIGHT FRAME AND WEIGHTS - FRONT HOOK	74
REAR HOOK-ADJUSTABLE - FOR ITALY	75
DRAWBAR	76
TOOL KIT	77

C-0011-19M-A

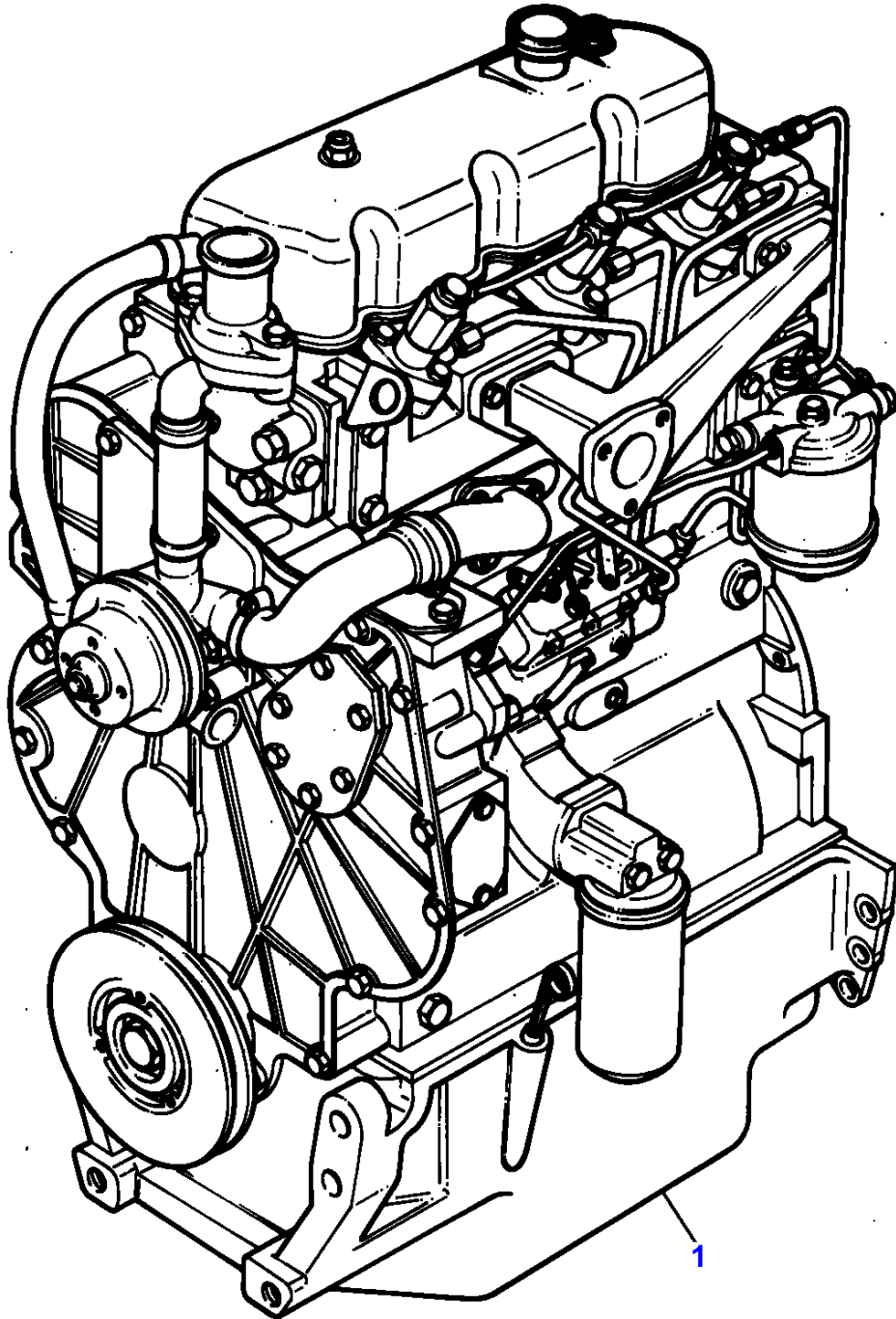

MASSEY FERGUSON

MF 254 CF CRAWLER - 3310806

3310806

ENGINE - D3.152 ENGINE

1

Item	Part Number	Qty	Description	Comments
				D3.152 ENGINE
1	CE31168	X	Parts Book	(A) (A) FOR MF254CF AND LANDINI 5830CF TRACTORS ONLY.

C-0560-25M-A

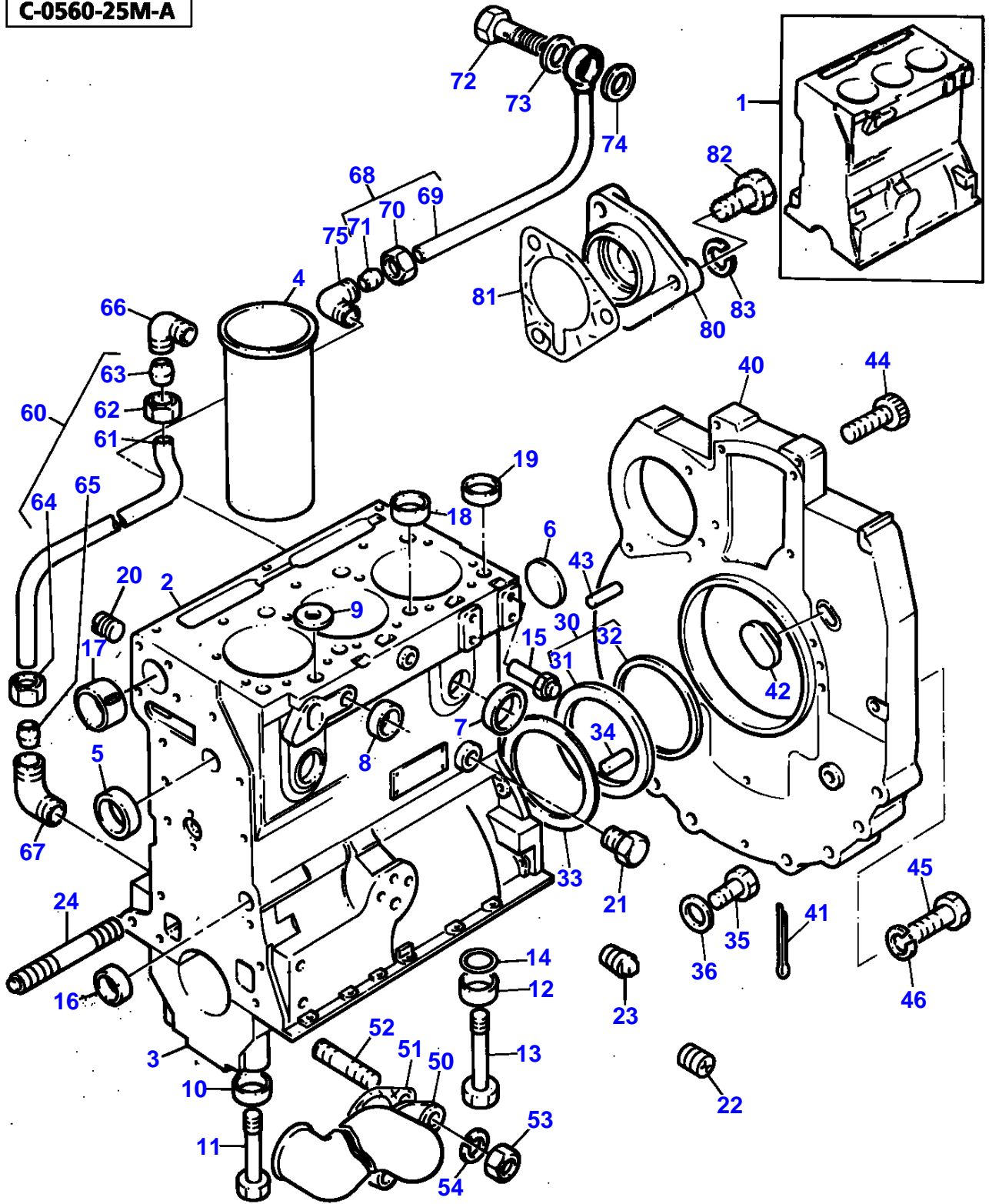

CYLINDER BLOCK - D3.152 ENGINE

Item	Part Number	Qty	Description	Comments
				D3.152 ENGINE
1	ZZ 50172	1	Kit,Cyl.Block	
2		1	Cylinder Block	(1) Not serviced, order REF.1
3		4	Bearing Cap	(1) Not serviced, order REF.1
4	31358323	3	Liner	(1) (A)
4	31358345	X	Liner	(B)
	31358357	X	Liner	(B) Thickness (+) 0.76MM Thickness (+) 0.030"
5	0650710	1	Plug	(1)
6	0650692	1	Plug	(1)
7	0650710	4	Plug	(1)
8	32417163	2	Plug	(1)
9	33141124	1	Plug	(1)
10	33137408	6	Thimble	(1)
11	32181441	6	Screw	(1)
12	33137408	2	Thimble	(1)
13	32181442	2	Screw	(1)
14	2415608	2	O Ring	(1)
15	2485A204	1	Plug	(1)
16	0650566	2	Plug	(1)
17	31134128	1	Bush	(1)
18	33157142	2	Plug	(1)
19	33157143	2	Plug	(1)
20	32114143	1	Plug	(1)
21	32161114	1	Plug	(1)
22	32114472	3	Plug	(1)
23	0650594	1	Plug	(1)
24	32537404	1	Stud	
30	4142V002	1	Housing	
31		1	Housing	(30) Not serviced, order REF.30
32	2418F475	1	Seal	(30)
33	33826111	1	Joint	
34	0350015	2	Dowel	
35	0746255	9	Setscrew	
36	0920003	9	Washer	
40	37147975	1	Plate	
41	0610045	1	Pin	
42	37813113	1	Plug	
43	0350016	2	Dowel	
44	0720798	2	Screw	
45	0746454	6	Setscrew	
46	0920054	6	Washer	
50	37736242	1	Connection	
51	0490486	1	Joint	
52	2217072	2	Stud	
53	0576002	2	Nut	
54	0920053	2	Washer	
60	35352404	1	Pipe,Oil	
61		1	Pipe	(60) Not serviced, order REF.60
62	0576111	1	Nut	(60)
63	0566002	1	Olive	(60)
64	0576111	1	Nut	(60)
65	0566002	1	Olive	(60)
66	0201047	1	Connection	
67	0201047	1	Connection	
68	35568109	1	Pipe,Oil	
69		1	Pipe	(68) Not serviced, order REF.68
70	0576111	1	Nut	(68)
71	0566002	1	Olive	(68)
72	0095350	1	Bolt	
73	0920126	1	Washer	
74	0920126	1	Washer	

MASSEY FERGUSON

MF 254 CF CRAWLER - 3310806

3310806

CYLINDER BLOCK - D3.152 ENGINE

2

Item	Part Number	Qty	Description	Comments
75	0201047	1	Connection	
80	37416753	1	Plate	
81	36862511	1	Joint	
82	2183205	3	Screw	
83	0920053	3	Washer	

(A)
PRESS FIT

(B)
SLIP FIT

C-0563-24M-A

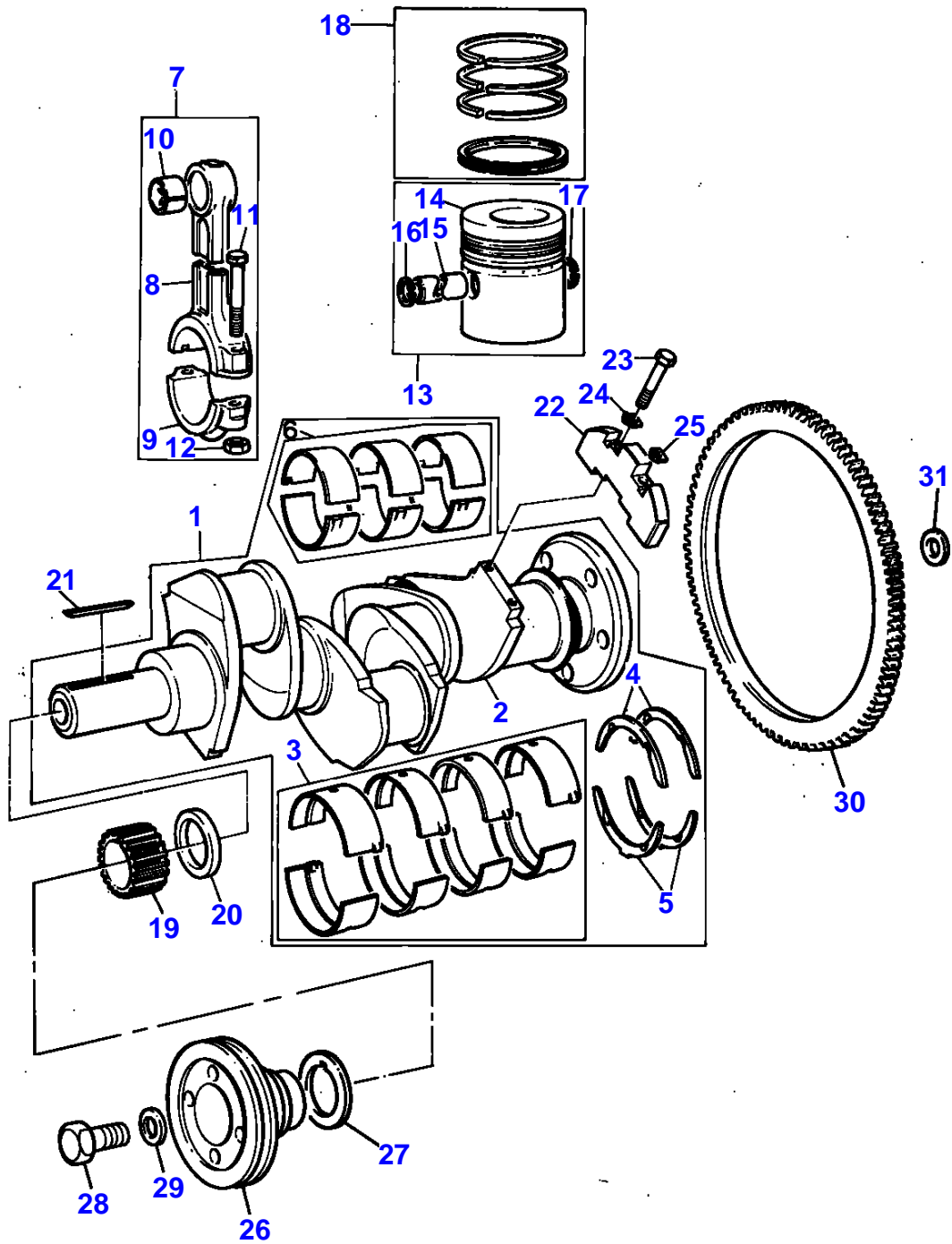

CRANKSHAFT, PISTONS AND CONNECTING RODS - D3.152 ENGINE

Item	Part Number	Qty	Description	Comments
				D3.152 ENGINE
1	ZZ 90078	1	Kit, Crankshaft	Repairs and replaces ZZ90122
2		1	Crankshaft	(1) Not serviced, order REF.1
3	68084	X	Kit, Bearing	(A)
	68084A	X	Kit, Bearing	(A) Thickness (-)0.25MM Thickness (-)0.010"
3	68084B	X	Kit, Bearing	(A) Thickness (-)0.50MM Thickness (-)0.020"
3	68084C	X	Kit, Bearing	(A) Thickness (-)0.75MM Thickness (-)0.030"
4	31137211	2	Thrust Washer	(1)
	31137212	X	Washer	Thickness (+)0.19MM Thickness (+)0.0075"
5	31137221	2	Thrust Washer	(1)
	31137222	X	Washer	Thickness (+)0.19MM Thickness (+)0.0075"
6	85036	1	Kit, Bearing	(1) (A)
6	85036A	X	Kit, Bearing	(A) Thickness (-)0.25MM Thickness (-)0.010"
6	85036B	X	Kit, Bearing	(A) Thickness (-)0.50MM Thickness (-)0.020"
6	85036C	X	Kit, Bearing	(A) Thickness (-)0.75MM Thickness (-)0.030"
7	ZZ 90010	1	Kit, Conrod	
8		1	Conrod	(7) Not serviced, order REF.7
9		1	Cap	(7) Not serviced, order REF.7
10	31134151	1	Bush	(7)
11	0095250	2	Bolt	(7)
12	33221327	2	Nut	(7)
13	68302	3	Kit, Piston	(B)
	89214	3	Kit, Piston	(C)
14		1	Piston	(13) Not serviced, order REF.13
15		1	Pin	(13) Not serviced, order REF.13
16	0170001	1	Circlip	(13)
17	0170001	1	Circlip	(13)
18	41158065	3	Kit, Piston Ring	
19	0410132	1	Gear,Crankshaft	Number of teeth/spines 25
20	0330811	1	Spacer	
21	36271704	1	Woodruff Key	
22	31328242	2	Weight	(D)
23	2185189	4	Screw	
24	31731515	2	Washer	
25	31731516	2	Washer	
26	31147788	1	Pulley,Crank	
27	33176137	1	Washer	
28	32162312	1	Screw	
29	33125112	1	Washer	
30	0410236	1	Starter Ring	Number of teeth/spines 115
31	33117127	6	Washer	Repairs and replaces 33117121

(A)
PRE-FINISHED

(B)
UNTOPPED

(C)

MASSEY FERGUSON

MF 254 CF CRAWLER - 3310806

3310806

CRANKSHAFT, PISTONS AND CONNECTING RODS - D3.152 ENGINE

3

Item	Part Number	Qty	Description	Comments
				PRE-TOPPED

(D)
REPLACES 31328241 IN ENGINE SETS ONLY(QTY 2).

C-0566-24M-A

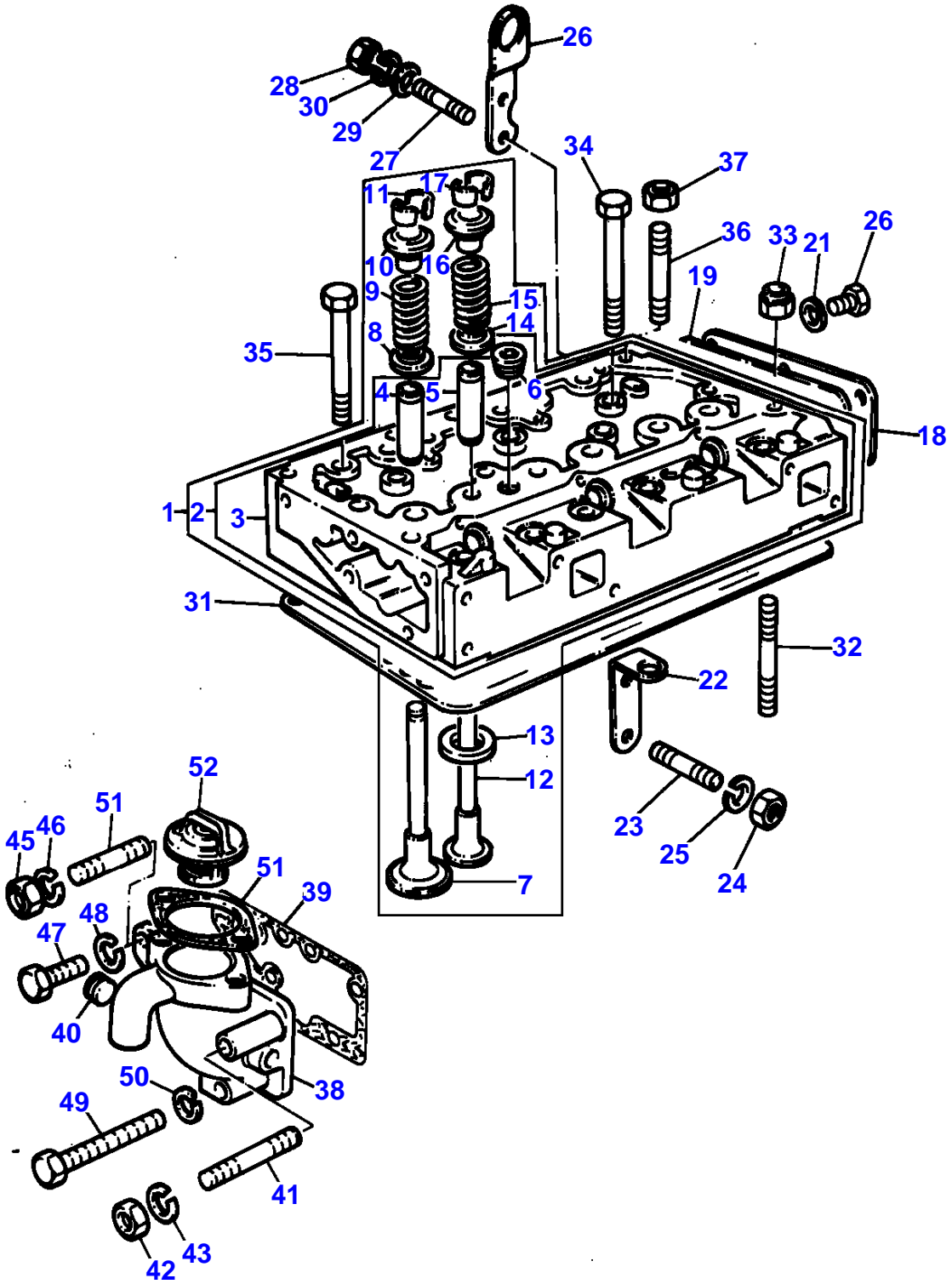

CYLINDER HEAD - D3.152 ENGINE

Item	Part Number	Qty	Description	Comments
				D3.152 ENGINE
1	ZZ 80082	1	Kit, Cyl. Head	
2	ZZ 80017	1	Kit, Cyl. Head	(1)
3		1	Cylinder Head	(2) Not serviced, order REF.2
4	33261723	3	Guide	(2)
5	33261723	3	Guide	(2)
6	2431154	1	Plug	(2)
7	31431681	3	Valve Inlet	(1)
8	33415133	3	Washer	(1)
9	0780012	3	Spring	(1)
10	33423148	3	Cap	(1)
11	0230001	6	Cotter	(1) (A)
12	3142A081	3	Valve Exhaust	(1) Repairs and replaces 31431031
13	3314A005	3	Insert	(1)
14	33415133	6	Washer	(1)
15	0780012	3	Spring	(1)
16	33423148	3	Cap	(1)
17	0230001	6	Cotter	(1) (A)
18	3612M002	1	Plate	
19	0490485	1	Joint	
20	0746254	6	Setscrew	
21	0920053	6	Washer	
22	36531408	1	Plate	
23	0826462	2	Stud	
24	0576051	2	Nut	
25	0920054	2	Washer	
26	36456321	1	Plate	
27	2216194	2	Stud	
28	0576051	2	Nut	
29	0920004	2	Washer	
30	0920054	2	Washer	
31	3681E015	1	Gasket	Repairs and replaces 3681E006
32	32524132	2	Stud	
33	33221329	2	Nut	
34	32181457	4	Screw	
35	32181458	9	Screw	
36	32524148	3	Stud	
37	33221329	3	Nut	
38		1	Housing	(B)
39		1	Joint	(B)
40		1	Plug	(B)
41		1	Stud	(B)
42		1	Nut	(B)
43		1	Washer	(B)
44		1	Stud	(B)
45		1	Nut	(B)
46		1	Washer	(B)
47		2	Screw	(B)
48		2	Washer	(B)
49		1	Screw	(B)
50		1	Washer	(B)
51		1	Joint	(B)
52		1	Thermostat	(B)
				(A) SERVICED IN PAIRS
				(B) SEE WATER PUMP SECTION

C-0569-20M-A

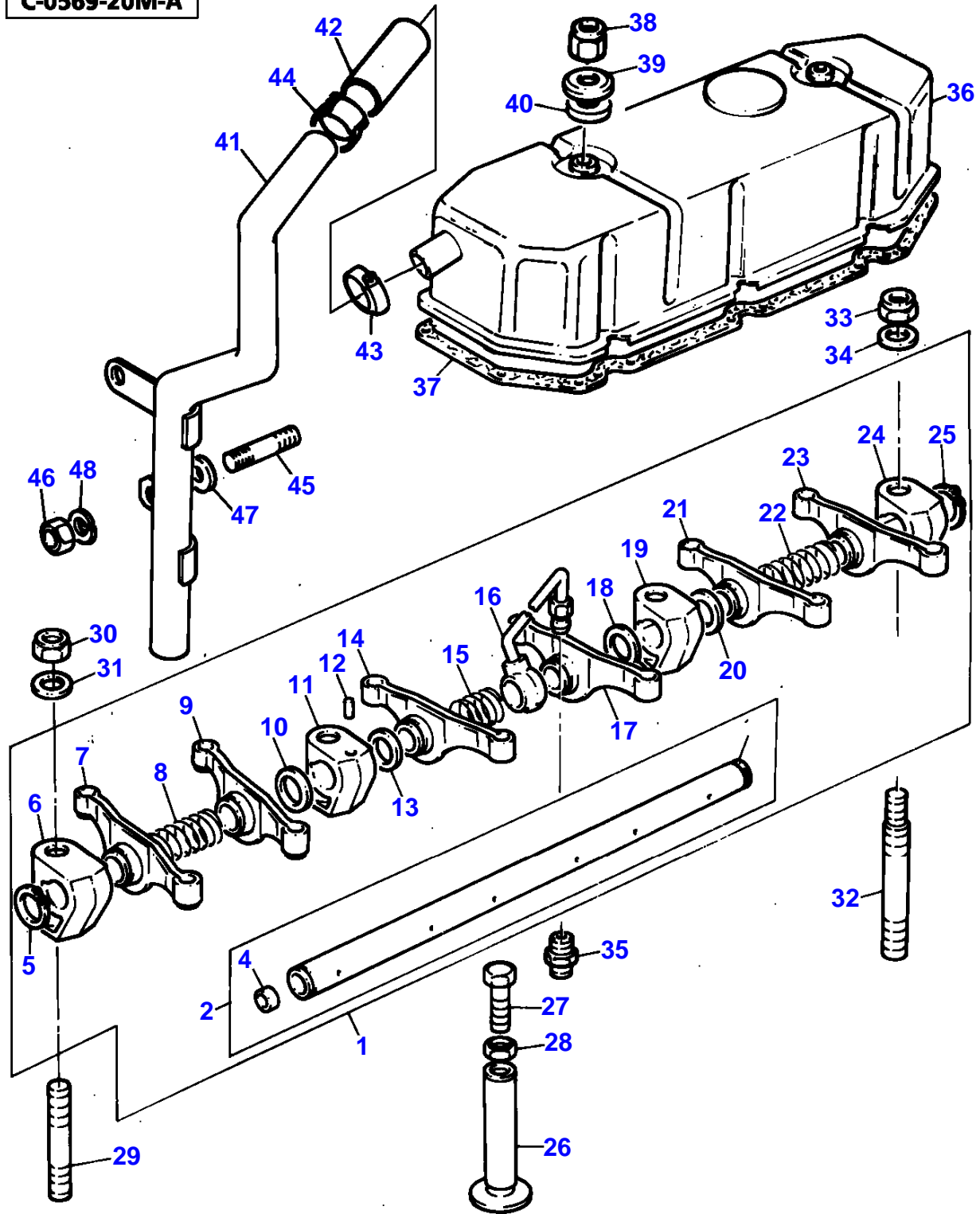

ROCKER SHAFT - D3.152 ENGINE

Item	Part Number	Qty	Description	Comments
				D3.152 ENGINE
1	4115R805	1	Rocker Shaft Ass	Repairs and replaces 4115R803
2	ZZ 90047	1	Rocker Shaft	(1)
3		1	Shaft	(2) Not serviced, order REF.2
4	0650507	2	Plug	(2)
5	0170033	2	Circlip	(1)
6	0101138	1	Bracket	(1)
7	3737A101	1	Lever	(1) Right Hand
8	0780005	1	Spring	(1)
9	3737A101	1	Lever	(1) Right Hand
10	0330505	1	Spacer	(1)
11	37521212	1	Bracket	(1)
12	2112A066	1	Pin	(1)
13	0330505	1	Spacer	(1)
14	3737A091	1	Lever	(1) Left Hand
15	0780175	1	Spring	(1)
16	35568352	1	Pipe,Oil	(1)
17	3737A101	1	Lever	(1) Right Hand
18	0330505	1	Spacer	(1)
19	0101138	1	Bracket	(1)
20	0330505	1	Spacer	(1)
21	3737A091	1	Lever	(1) Left Hand
22	0780005	1	Spring	(1)
23	3737A091	1	Lever	(1) Left Hand
24	0101138	1	Bracket	(1)
25	0170033	1	Circlip	(1)
26	0860012	6	Tappet	
27	32151116	6	Screw	
28	0576052	6	Nut	
29	2214209	2	Stud	
30	2211283	2	Nut	
31	0920004	2	Washer	
32	32754435	2	Stud	
33	2211283	2	Nut	
34	0920004	2	Washer	
35	0206002	1	Union	
36	37188557	1	Cyl.Head Cover	
37	36811115	1	Joint	
38	0576102	2	Nut	
39	3314P004	2	Washer	
40	3381A003	2	Washer	
41	35732479	1	Pipe,Breather	
42	0202058	1	Hose	
43	21825195	1	Clip	Repairs and replaces 2481863
44	21825195	1	Clip	Repairs and replaces 2481863
45	2217572	1	Stud	
46	0576002	1	Nut	
47	0920460	1	Spacer	
48	0920053	1	Washer	

Buy Now



Our support email:

ebooklibonline@outlook.com