

Page Title	Page Number
Engine & Equipment - AGCO POWER SISU IEGR	010-0005
Engine & Equipment - AGCO POWER SISU w/ e3 Technology	010-0010
Alternator & Bracket	010-0015
Alternator & Bracket - ENGINE WITH AIR COMPRESSOR	010-0020
Cylinder Block	010-0025
Timing Gear Housing	010-0030
Crankshaft, Piston & Connecting Rods	010-0035
Valve Mechanism And Camshaft	010-0040
Cylinder Head	010-0045
Cylinder Head Cover	010-0050
Oil Sump	010-0055
Lubricating Oil Cooler And Filter - AGCO POWER SISU IEGR	010-0060
Lubricating Oil Cooler And Filter - AGCO POWER SISU w/ e3 Technology	010-0065
Water Pump - AGCO POWER SISU IEGR	010-0070
Water Pump - AGCO POWER SISU w/ e3 Technology	010-0075
Injection System	010-0080
Low Pressure Fuel System	010-0085
Air Induction & Exhaust	010-0090
Turbocharger - Pipes	010-0095
Air Compressor - Up To V174005	010-0100
Air Compressor - FROM V174006	010-0105
Electronic Engine Management	010-0110
Engine Parts - AGCO POWER SISU w/ e3 Technology	010-0115
Engine Repair Kits - Piston- Cylinder Head With Valves	010-0120
Engine Gaskets Sets	010-0125
Heater Engine Block - 110V - AGCO POWER SISU IEGR Up To V074010	010-0130
Heater Engine Block - 110V - AGCO POWER SISU IEGR From V074011	010-0135
Heater Engine Block - 220V - AGCO POWER SISU IEGR Up To V118035	010-0140
Heater Engine Block - 220V - AGCO POWER SISU IEGR From V118036	010-0145
Heater Engine Block - 110V - AGCO POWER SISU w/ e3 Technology	010-0150
Heater Engine Block - 220V - AGCO POWER SISU w/ e3 Technology	010-0155
Cab Heating System - Engine Part - AGCO POWER SISU IEGR	010-0160
Cab Heating System - Engine Part - AGCO POWER SISU w/ e3 Technology	010-0165
Cab Heating System - Engine Part - AGCO POWER SISU w/ e3 Technology - With Engine Bloc Heater	010-0170
Fuel Tank & Attachments - AGCO POWER SISU w/ e3 Technology - Up To U139025	010-0175
Fuel Tank & Attachments - AGCO POWER SISU w/ e3 Technology - From U139026	010-0180
Fuel Tank & Attachments - AGCO POWER SISU w/ e3 Technology	010-0185
Tank Assembly - AGCO POWER SISU w/ e3 Technology	010-0190
Fuel Tank & Attachments - AGCO POWER SISU IEGR - Up To U139025	010-0195
Fuel Tank & Attachments - AGCO POWER SISU IEGR - From U139026	010-0200
Fuel Tank & Attachments - AGCO POWER SISU IEGR	010-0205
Additional Tank	010-0210
Fuel Pipes	010-0215
Fuel System	010-0220
Batteries And Cables	010-0225
Cooling System - Air Conditioned Installation	010-0230
Cooling System - Air Conditioned Installation - ENGINE WITH AIR COMPRESSOR	010-0235
Compressor	010-0240
Cooling System - Engine	010-0245
Cooling System - Engine	010-0250
Air Cooler	010-0255
Oil Cooler	010-0260
Air Filter - Dry - Dual Element	010-0265

Massey Ferguson

8680 TRACTOR (TIER 2-3 / 84 CTA Engine) - PHASED OUT 2011 - 3906237

3906237

Engine & Equipment

Page010-0000

Vertical Exhaust On The Side - AGCO POWER SISU IEGR	010-0270
Vertical Exhaust On The Side - AGCO POWER SISU w/ e3 Technology	010-0275
Pollution Control - AGCO POWER SISU w/ e3 Technology	010-0280
Throttle Controls	010-0285

1-WA06-052-F

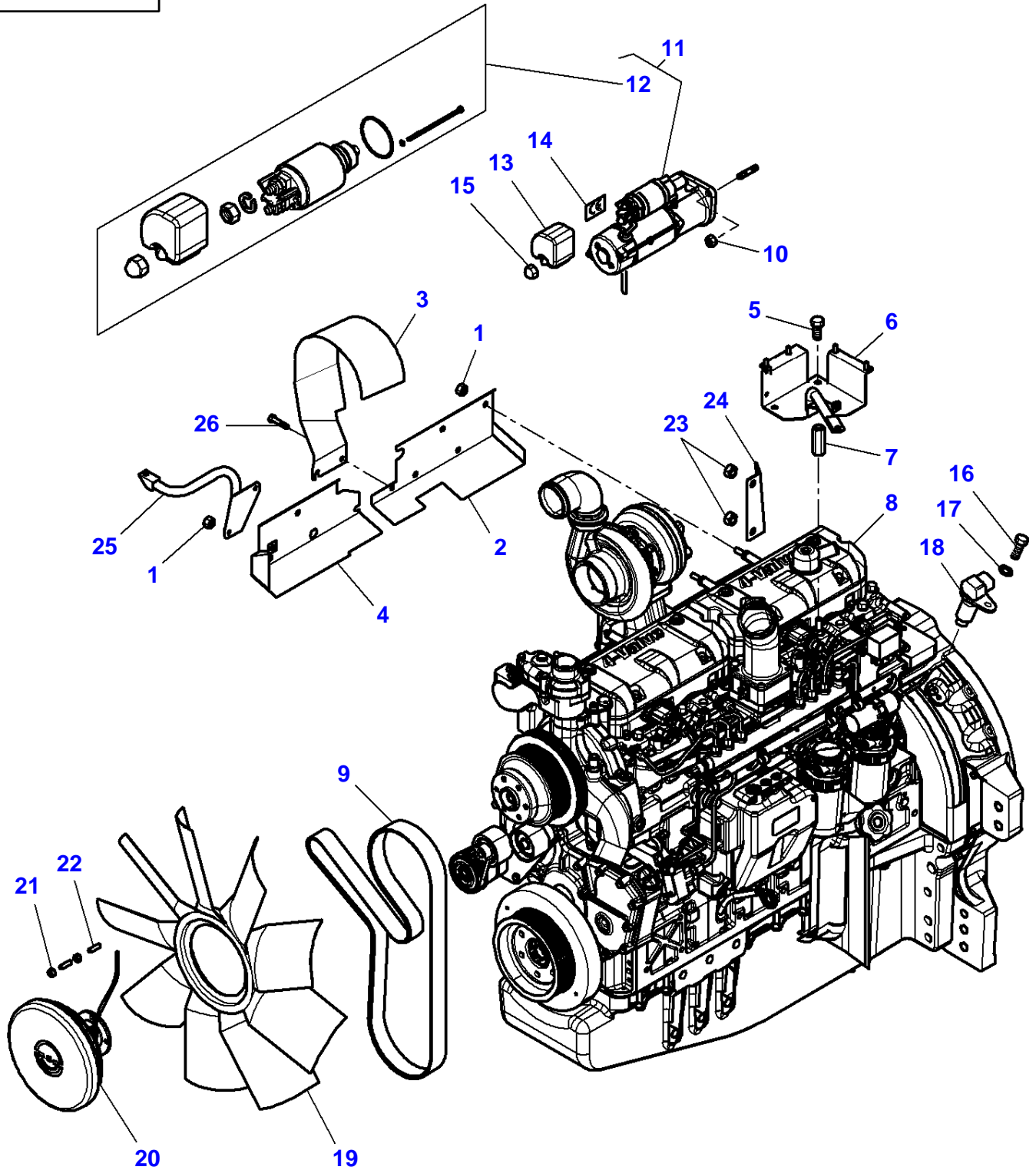

Item	Part Number	Qty	Description	Comments
1	339402X1	8	Nut	M10
2	4298355M1	1	Cowl	
3	4286694M3	1	Cowl	
4	4298356M2	1	Cowl	
5	3009505X1	2	Hex Cap Screw	M12 X 25
6	4293496M5	1	Support	
7	4295688M2	2	Spacer	M12 X 60
8	V835261828	1	Engine	Up to Serial or Engine Number V186024 84 CTA
	V835276510	1	Engine	From Serial or Engine Number V186025 84 CTA
	V865261828X	1	Short Engine	[C] Up to Serial or Engine Number V186024
	V865276510X	1	Short Engine	[C] From Serial or Engine Number V186025
9	4348738M1	1	Belt	Length 2040 MM
10	339402X1	3	Nut	M10
11	4288991M4	1	Startermotor	[A]
12	3905503M92	1	Kit, Solenoid	(11)
13	3786093M1	1	Protection.	
14	3788193M1	1	Label	
15	3786092M1	1	Nut	M10
16	3009285X1	1	Hex Socket Screw	8 X 16
17	339374X1	1	Lock Washer	
18	72476629	1	Hall Sensor	
19	72455948	1	Fan	
20	4291948M2	1	Clutch	
21	339402X1	4	Nut	M10
22	3011339X1	4	Stud	Up to Serial or Engine Number U330008 M10 X 22
	1442072X1	4	Stud	From Serial or Engine Number U330009 M10 X 20
23	339402X1	2	Nut	M10
24	4297488M2	1	Support	
25	4295763M2	1	Support	[D] From Serial or Engine Number U021088
26	339124X1	1	Hex Cap Screw	M8 X 16

FOOTNOTE [A] THE APPROPRIATE SAFETY DECALS MUST BE ORDERED AND FITTED TO THIS PART

FOOTNOTE [C] NOT ILLUSTRATED

FOOTNOTE [D] ENGINE WITHOUT AIR COMPRESSOR

1-WA10-023-B

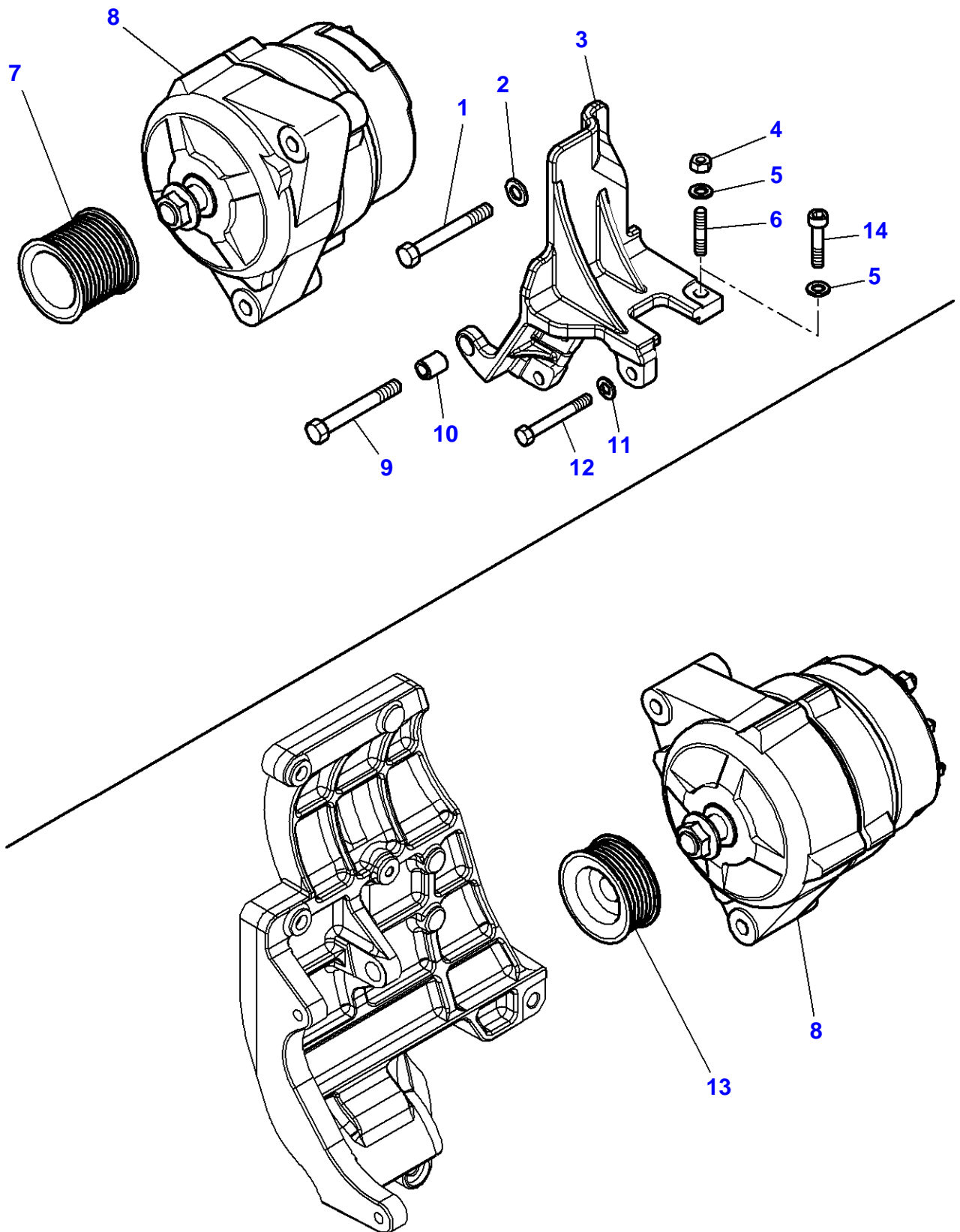

Alternator & Bracket

Item	Part Number	Qty	Description	Comments
1	3009502X1	1	Hex Cap Screw	M10 X 80
2	390734X1	1	Flat Washer	
3	4288085M4	1	Support	
4	339169X1	1	Nut	Up to Serial or Engine Number V014039 M8
5	390972X1	1	Flat Washer	
6	391001X1	1	Stud	Up to Serial or Engine Number V014039
7	4289356M1	1	Pulley	Diameter 47
8	4287014M4	2	Alternator	14V - 120A
9	3009503X1	1	Hex Cap Screw	M10 X 90
10	4282164M1	1	Spacer	Diameter 10.3-15 X 18
11	390972X1	3	Flat Washer	
12	339291X1	3	Hex Cap Screw	M8 X 55
13	4287017M1	1	Pulley	
14	391990X1	1	Hex Socket Screw	From Serial or Engine Number V014040

1-WA10-024-A

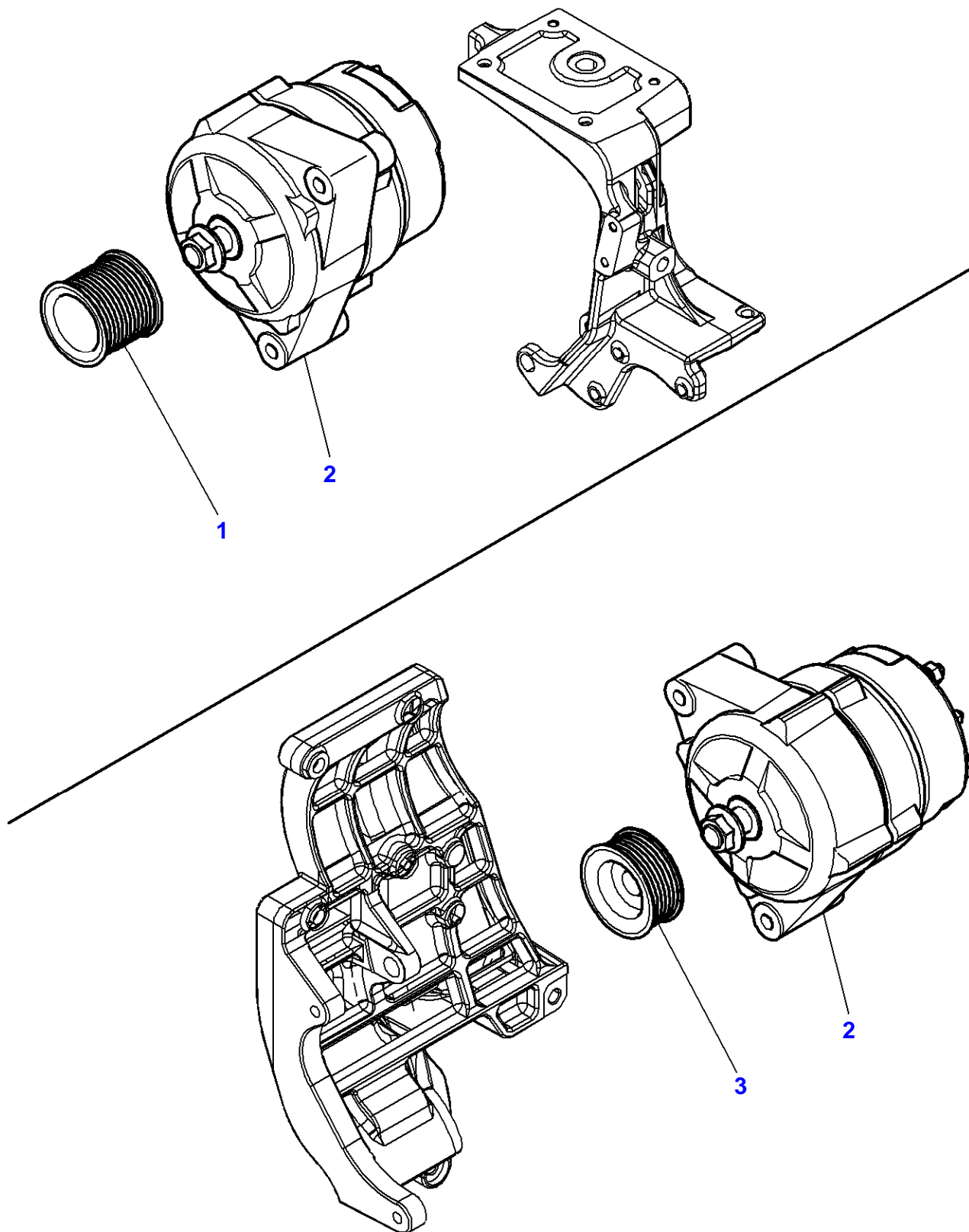

Massey Ferguson

8680 TRACTOR (TIER 2-3 / 84 CTA Engine) - PHASED OUT 2011 - 3906237

3906237

Alternator & Bracket - ENGINE WITH AIR COMPRESSOR

Page010-0020

Item	Part Number	Qty	Description	Comments
1	4289356M1	1	Pulley	Diameter 47
2	4287014M4	2	Alternator	14V - 120A
3	4287017M1	1	Pulley	

1-WH01-020-C

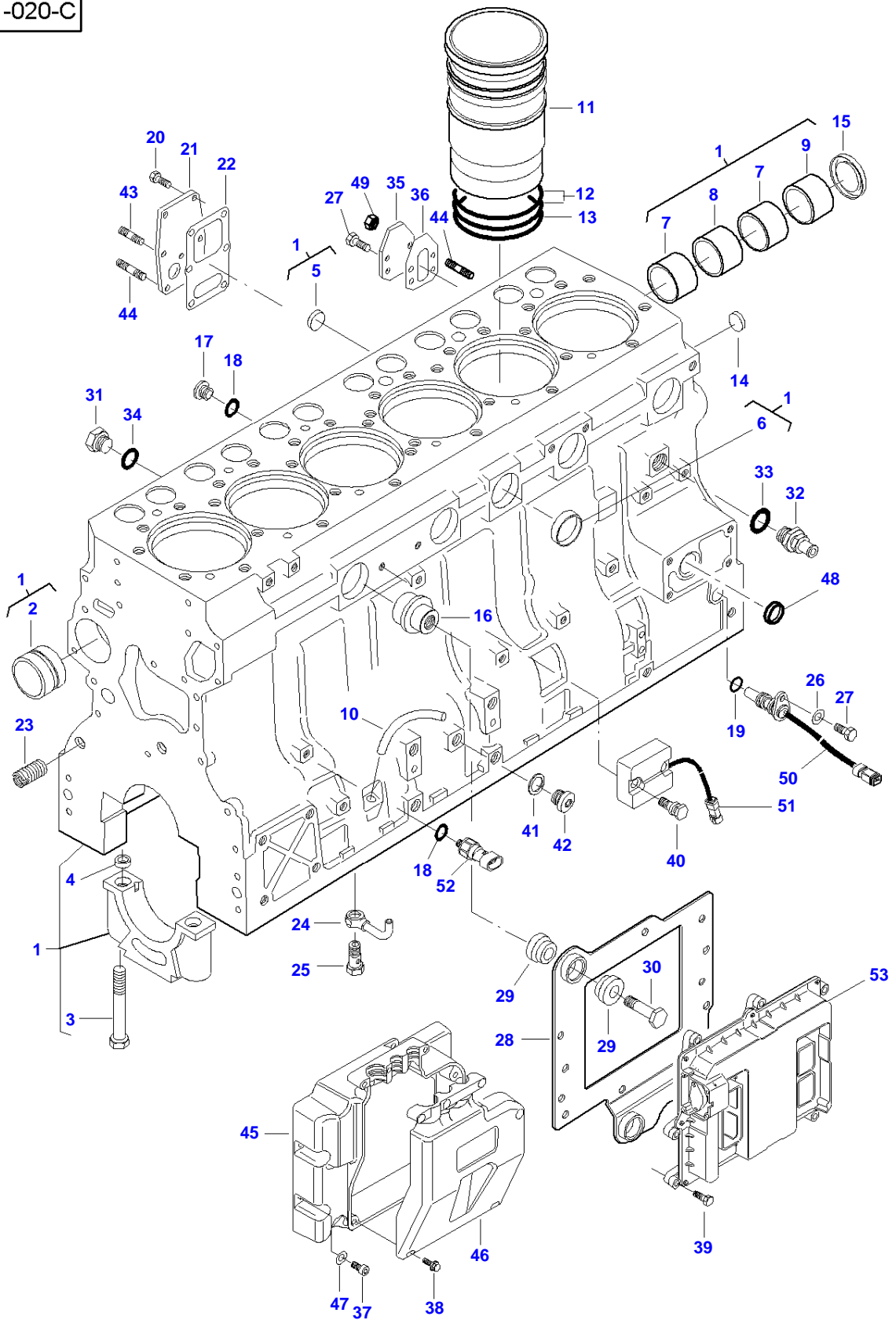

Cylinder Block

Item	Part Number	Qty	Description	Comments
1	V836873095	1	Cylinder-Block	
2	V836866069	1	Bush	(1)
	V836866036	X	Bush	Thickness +0,4 MM
3	V529903180	14	Hex Cap Screw	(1)
4	V836214478	24	Bush	(1)
5	V640016018	1	Plug	(1)
6	V640016040	4	Plug	(1)
7	V836852460	2	Bush	(1)
8	V836852459	1	Bush	(1)
9	V836852461	1	Bush	(1)
10	V836873278	1	Pipe	
11	V836867048	6	Liner	
	V836867050	X	Liner	Thickness 9,08 MM
12	V836855446	12	O Ring	
13	V836855447	6	O Ring	
14	V640016016	4	Plug	
15	V836852744	1	Plug	
16	V837069057	1	Plug	
17	V640325110	6	Plug	
18	V615871014	7	Sealing Washer	
19	VKH7070	1	O Ring	
20	V528801380	5	Hex Cap Screw	M8 X 20
21	V836855678	1	Cover	
22	V836322852	1	Joint	
23	V836859153	1	Nipple	
24	V837070021	6	Pipe	
25	V836338601	6	Valve	
26	V500050842	1	Flat Washer	
27	V528801362	3	Hex Cap Screw	M8 X 16
28	V837070147	1	Bracket	
29	V837074327	6	Rubber Bush	
30	V837069056	3	Hex Cap Screw	
31	V836119079	1	Oil Drain Plug	
32	V836664377	1	Cock	
33	V615881824	1	Sealing Washer	
34	V615881620	1	Sealing Washer	
35	V836866957	1	Cover	
36	V836866958	1	Joint	
37	V581804182	5	Hex Socket Screw	M6 X 16
38	V590253388	6	Carriage Bolt	5.1 X 14
39	V528801102	8	Hex Cap Screw	M6 X 25
40	V837070197	2	Hex Cap Screw	
41	V615881420	1	Sealing Washer	
42	V640325014	1	Oil Drain Plug	
43	V546801360	1	Stud	M8 X 16
44	V546801400	3	Stud	M8 X 25
45	V837070285	1	Cover	M8 X 25
46	V837070286	1	Cover	
47	V500150642	5	Flat Washer	
48	V640016035	1	Plug	[A]
49	V504800800	2	Nut	M8
50		1	Speed Sensor	See Page - Reference Number 010-0110/5
51		1	Module	See Page - Reference Number 010-0110/23
52		1	Sensor	See Page - Reference Number 010-0110/3
53		1	Control Unit	See Page - Reference Number 010-0110/1

FOOTNOTE [A] AGCO POWER SISU W/ E3 TECHNOLOGY

1-WH20-012-D

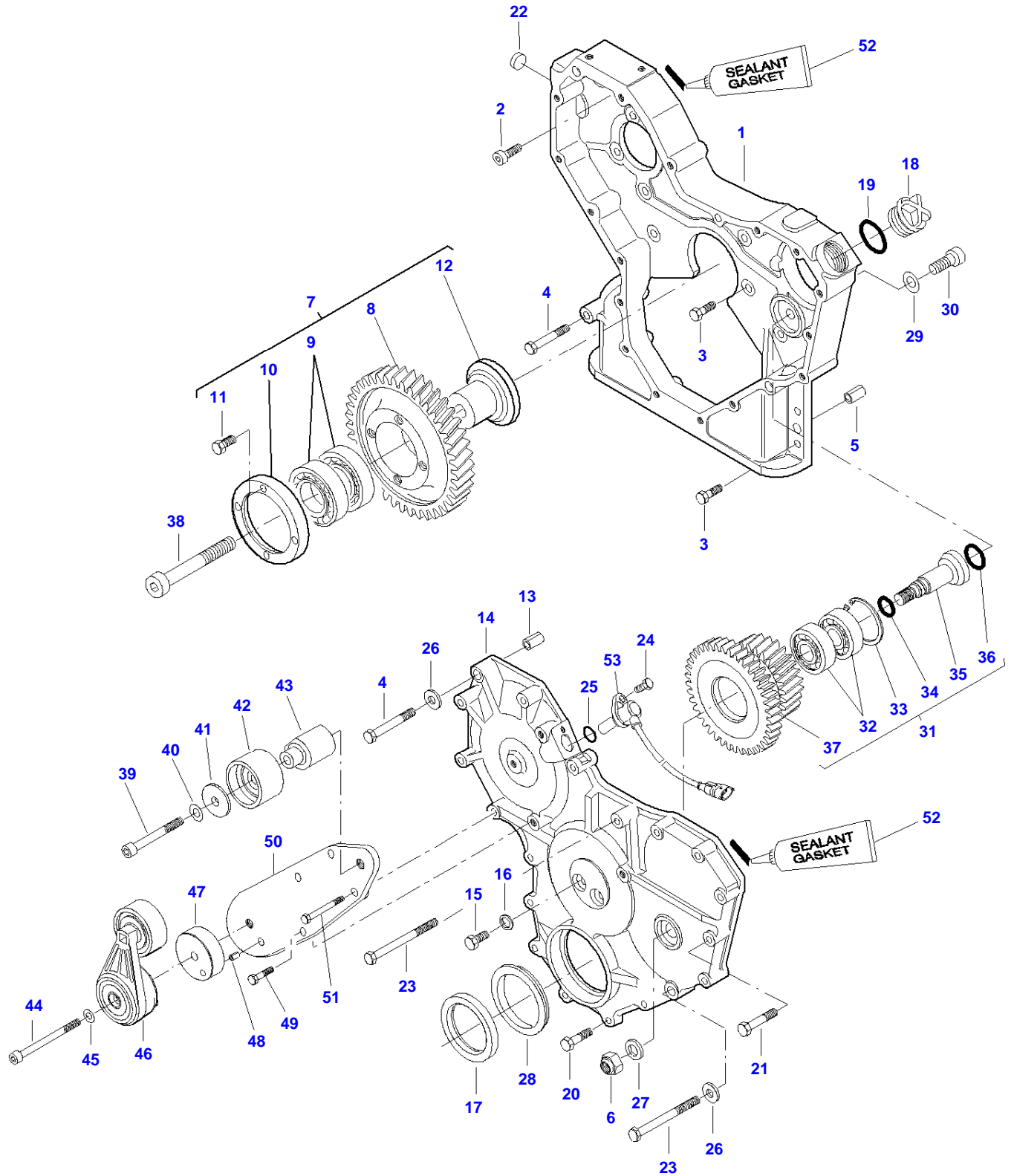

Timing Gear Housing

Item	Part Number	Qty	Description	Comments
1	V837070062	1	Housing	
2	V581804620	2	Hex Socket Screw	M8 X 25
3	V528801400	13	Hex Cap Screw	M8 X 25
4	V529801470	2	Hex Cap Screw	M8 X 60
5	V598359850	2	Pin	
6	V504601400	1	Nut	M14
7	V837070001	1	Kit, Gear	
8	V837070000	1	Gear	(7)
9	V610072109	1	Ball Bearing	(7)
10	V836855565	1	Ring	(7)
11	V528901400	4	Hex Cap Screw	(7) M8 X 16
12	V836855562	1	Shaft	(7)
13	V598359850	2	Pin	
14	V837070162	1	Cover	
15	V528801380	2	Hex Cap Screw	M8 X 20
16	V615870814	2	Sealing Washer	
17	V836840883	1	Oil Seal	
	V836873100	X	Spacer	Thickness 3.00 MM
18	V836017927	1	Plug	
19	V614603540	1	O Ring	
20	V528801410	6	Hex Cap Screw	M8 X 30
21	V529801440	10	Hex Cap Screw	M8 X 45
22	V640016016	1	Plug	
23	V529801540	1	Hex Cap Screw	M8 X 95
24	V528801062	1	Hex Cap Screw	M6 X 16
25	V614601718	1	O Ring	
26	V836120989	2	Flat Washer	
27	V837069070	1	Washer	
28	V836855636	1	Gasket	
29	V500951200	1	Flat Washer	
30	V581705420	1	Hex Socket Screw	M12 X 25
31	V837070086	1	Gear	
32	V610073040	2	Ball Bearing	(31)
33	V617330052	1	Circlip	(31)
34	V614601324	1	O Ring	(31)
35	V837069069	1	Shaft	(31)
36	V614601924	1	O Ring	(31)
37	V837070112	1	Gear	(31)
38	V581705910	1	Hex Socket Screw	M14 X 70
39	V581705520	1	Hex Socket Screw	M12 X 80
40	V500951200	1	Flat Washer	
41	V836866312	1	Washer	
42	V836866321	1	Pulley	
43	V837073198	1	Shaft	
44	V581805170	1	Screw	M10 X 100
45	V500951000	1	Flat Washer	
46	V837073101	1	Pulley, Tensioner	
47	V836867902	1	Spacer	
48	V595954600	1	Pin	
49	V528801410	1	Hex Cap Screw	M8 X 30
50	V836873549	1	Plate	
51	V529801470	2	Hex Cap Screw	M8 X 60
52	V836662735	1	Sealing Compound	
53		1	Speed Sensor	See Page - Reference Number 010-0110/6

1-WH02-020-B

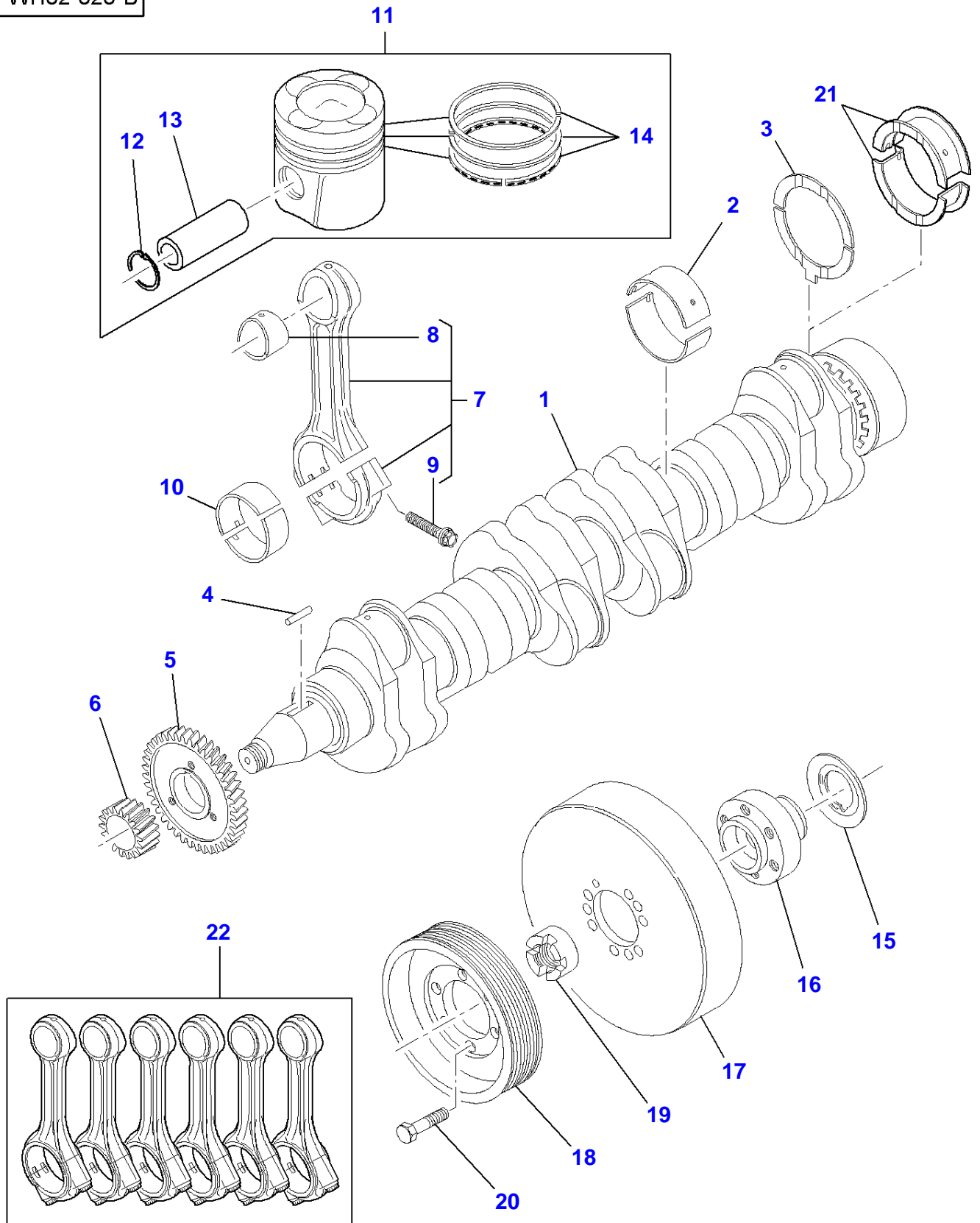

Crankshaft, Piston & Connecting Rods

Item	Part Number	Qty	Description	Comments
1	V837069088	1	Crankshaft	Up to Serial or Engine Number X01818
	V837073996	1	Crankshaft	From Serial or Engine Number X01819
2	V836840944	7	Main Bearing	
	V836840978	X	Main Bearing	Diameter 89,735 MM 89,770 MM
	V836840979	X	Main Bearing	Diameter 89,485 MM 89,520 MM
	V836840980	X	Main Bearing	Diameter 88,985 MM 89,020 MM
	V836840981	X	Main Bearing	Diameter 88,485 MM 88,520 MM
3	V836840945	2	Thrust Washer	Up to Serial or Engine Number
	V836840982	X	Thrust Washer	0,10 MM
	V836840983	X	Thrust Washer	0,20 MM
4	V836855525	1	Key	
5	V836855558	1	Gear	STANDARD
6	V837069060	1	Gear	Up to Serial or Engine Number X01818
	V837074434	1	Gear	From Serial or Engine Number X01819
7	V836340948	6	Kit, Conrod	Up to Serial or Engine Number X02392
		6	Kit, Conrod	From Serial or Engine Number X02393 Not serviced,order Ref 22
	V836864101	X	Conrod	2230-2249g E
	V836864102	X	Conrod	2250-2269g F
	V836864103	X	Conrod	2270-2289g G
	V836864104	X	Conrod	2290-2309g H
	V836864105	X	Conrod	2310-2329g I
	V836864106	X	Conrod	2330-2349g J
	V836864107	X	Conrod	2350-2369g K
8	V836864288	6	Bush	(7)
	V836338606	X	Bush	Diameter + 0,5 MM
9	V836864141	12	Screw	(7)
	V836873510	12	Screw Special	Up to Serial or Engine Number X02392 (7) From Serial or Engine Number X02393
10	V836338650	X	Bearing	Diameter 72,731 MM 72,750 MM
	V836338651	X	Bearing	Diameter 72,481 MM 72,500 MM
	V837062996	6	Bearing	
	V836338652	X	Bearing	Diameter 71,981 MM 72,000 MM
	V836338653	X	Bearing	Diameter 71,481 MM 71,500 MM
11	V837074162	6	Piston	
12		12	Circlip	(11) Not serviced,order REF. 11
13		6	Clevis Pin	(11) Not serviced,order REF. 11
14	V836840887	6	Kit, Piston Ring	(11)
15	V836855637	1	Ring	
16	V836855641	1	Hub	
17	V836840882	1	Shock Absorber	M12 X 40
18	V836855690	1	Pulley	
19	V836322221	1	Nut	M33 X 2
	V836847641	1	Nut	Up to Serial or Engine Number X01818 From Serial or Engine Number X01819 M33 X 1.5
20	V528902230	6	Hex Cap Screw	M12 X 40
21	V836879152	1	Thrust Washer	From Serial or Engine Number
22	V837079475	1	Kit, Conrod	From Serial or Engine Number X02393

Buy Now



Our support email:

ebooklibonline@outlook.com