

FORD



Operator's Manual

42'' & 48'' Mower Attachment LGT Tractors

Models 9607443 and 9607444

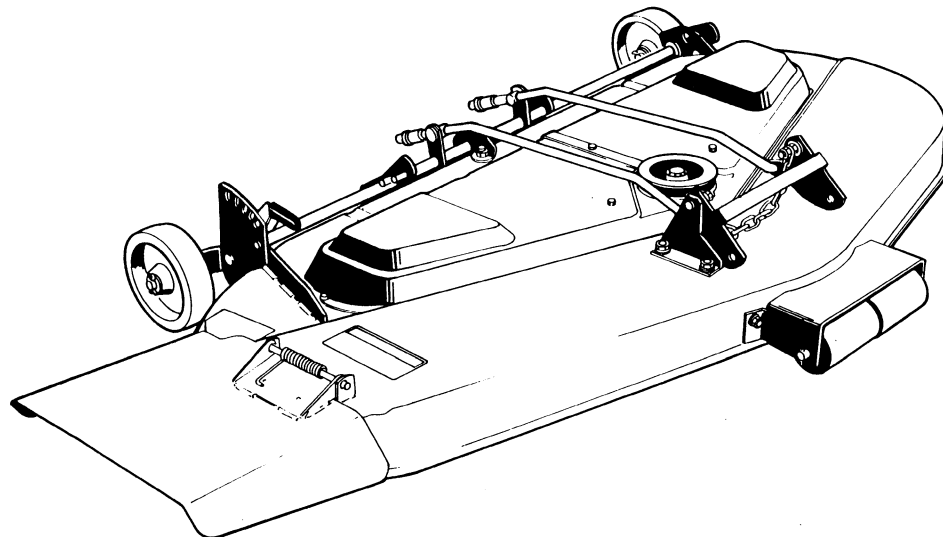

42644222

Reprinted

INTRODUCTION

This operator's manual has been prepared to provide the information you need to correctly assemble, operate and maintain your unit. Read it carefully and keep it for future reference. Should you ever need repair parts or service, contact your authorized parts and service dealer.

Be sure safety precautions are observed. Read and follow all safety and operating instructions in the operator's manual.

Any references made in this manual concerning the right- or left-hand sides are determined with the operator facing forward in the operating position.

The replacement of any part on this product by other than the manufacturer's authorized replacement part may adversely affect the performance, durability or safety of this product.

The manufacturer reserves the right to make changes on, or add improvements to its product at any time without prior notice or obligation. The manufacturer also reserves the right to decide, upon its discretion and at any time, to discontinue a product.

NOTICE: Record the model and serial numbers of your unit (located on the nameplate) in the spaces provided below.

Product Model No. _____

Product Serial No. _____

Dealer Purchased From _____

Date Purchased _____

Dealer Address _____

Dealer Telephone No. _____

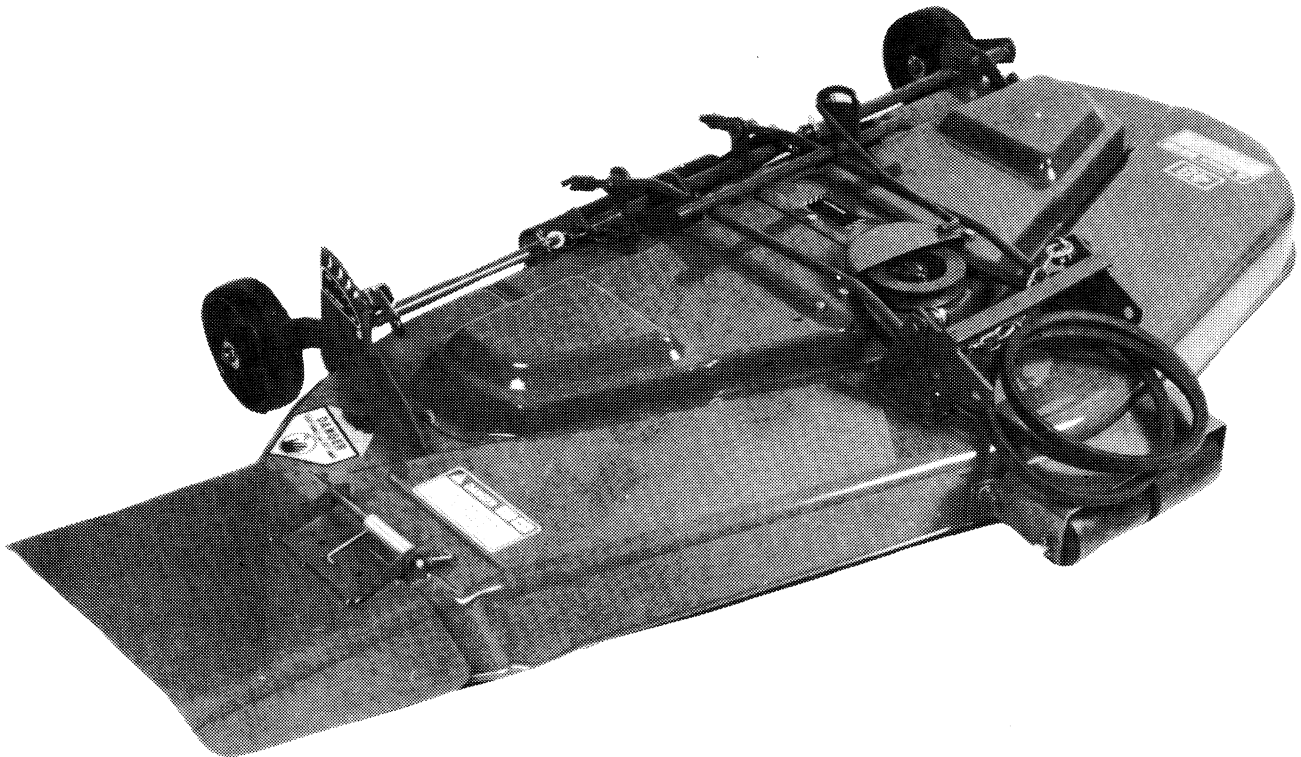

TABLE OF CONTENTS

1 Safety Precautions	1.1	4 Adjustment And Servicing	
Controls And Operation		Mower Deck Pitch	4.1
Discharge Guard	2.1	Spindle Bearings	4.1
Controls	2.1	Mower Belt	4.2
Mower Lift	2.1	Drive Belt	4.3
Cutting Height	2.1	Belt Installation Diagram.....	4.3
Cutting Speed	2.1	5 Storage/Trouble Shooting	5.1
Grass Discharge	2.2	6 Set-Up And Assembly	6.1-6.5
Cutting Patterns	2.2	7 Replacement Decals	
3 Maintenance And Lubrication		Safety	7.1
Daily Schedule	3.1	Standard	7.1
25 Hour Schedule	3.1	8 Replacement Parts And Parts Lists	
Blade Sharpening	3.2	9 Owner Assistance	
Blade Balancing	3.2		

IMPORTANT: If decals are missing, illegible, or damaged, they should be replaced.

1 SAFETY PRECAUTIONS

THE FOLLOWING PRECAUTIONS ARE SUGGESTED TO HELP PREVENT ACCIDENTS.

A CAREFUL OPERATOR IS THE BEST OPERATOR. MOST ACCIDENTS CAN BE AVOIDED BY OBSERVING CERTAIN PRECAUTIONS. READ AND TAKE THE FOLLOWING PRECAUTIONS BEFORE OPERATING THIS EQUIPMENT TO HELP PREVENT ACCIDENTS. EQUIPMENT SHOULD BE OPERATED ONLY BY THOSE WHO ARE RESPONSIBLE AND INSTRUCTED TO DO SO.

TRAINING

- Read the Tractor and Mower Operators Manual **carefully** before using the equipment. **Do not** allow adults to operate mower without proper instruction. Lack of operating knowledge can lead to accidents.
- **Never** allow children to operate mower. Be sure the children are out of the way and stay away until the job is done.
- Know your controls. Know how to stop tractor and engine in an emergency.

PREPARATION

- Keep the vehicle and attachments in good operating condition and keep safety devices in place.
- **Do not** modify or alter or permit anyone else to modify or alter this mower or any of its components or any tractor function.
- All shields and guards **must** be in place **before** operating mower.
- Be sure lawn is clean. Remove stones, wires, sticks, toys - anything that might catch or be thrown by the mower blade.
- **Do not** wear loose fitting clothing that might get caught in moving parts.
- Keep hands and feet away from moving parts.
- Clear the area of people and pets.

OPERATION

- Disengage power to mower when transporting or not in use.
- Disengage power to mower **before** backing up.
- **Do not** mow in reverse unless absolutely necessary and then **only after** careful observation of the entire area behind the mower.
- When mowing proceed as follows:
 - a) Mow **only** in daylight or in good artificial light.
 - b) **Never** make a cutting height adjustment while the engine (motor) is running if the operator must dismount to do so.
 - c) Check the blade mounting bolts for proper tightness at frequent intervals.

- d) Shut the engine (motor) off when removing the grass catcher or unclogging chute.
- Watch for holes in terrain and other hidden hazards. Keep away from drop offs.
 - **Do not** stop or start suddenly when going uphill or downhill. Mow up and down the face of steep slopes, **never** across the face.
 - Disengage power to attachment(s) and stop the engine (motor) **before** leaving the operator's position.
 - Stop operation and disengage P.T.O. when another person approaches.
 - Set parking brake and stop engine **before** leaving seat.
 - Reduce speed on all side slopes and sharp turns to prevent tipping or losing control.
 - **Do not** allow anyone to ride on tractor or any of its attachments.
 - **Never** allow mower to discharge grass toward anyone.
 - The discharge guard **must** be down at all times during mowing operation.

MAINTENANCE & SERVICING

- Keep all guards and shields in place.
- Replace safety and warning decals when they become damaged or if any portion becomes illegible.
- The vehicle and attachments should be stopped and inspected for damage after striking a foreign object and the damage should be repaired **before** restarting and operating the equipment.
- **Do not** lubricate or make mechanical adjustments while the unit is in motion or when the engine is running. However, if minor engine adjustments must be made, apply the parking brake securely, block the wheels and use extreme caution.
- Periodically maintain mower. Tighten nuts, bolts and fittings periodically for safe operation. Check blade for tightness.

SAFETY DEFINITIONS

 **DANGER**

The signal word "DANGER" signifies that a source of extreme danger to a person on or near a machine exists as a result of the very nature of the machine itself. This danger to persons is such that it would result in a high likelihood of death or permanent injury if the recommended precautions are not taken.

When you see this symbol



it means: ATTENTION!

 **WARNING**

The signal word "WARNING" indicates that a source of danger to a person on or near a machine exists which may result in death or injury if the recommended precautions are not taken.

BECOME ALERT! YOUR SAFETY IS INVOLVED!

2 CONTROLS AND OPERATION

DISCHARGE GUARD

The discharge guard is assembled to the mower at the factory, ready to use.

WARNING: To avoid personal injury, the discharge guard must be in place and secure when operating mower.

CONTROLS

Review operation of all tractor controls in tractor operator's manual. Power to the mower is controlled by the tractor's P.T.O. The P.T.O. must be OFF unless you are cutting grass.

MOWER LIFT

Lift is controlled by the attachment lift lever or implement lift on your tractor (see your tractor's operator's manual). **NOTE:** On some models of tractors, the attachment lift may not raise the mower gage wheels when cutting height adjustment handle is in high cut position.

WARNING: To avoid personal injury, do not operate mower in the transport position.

CUTTING HEIGHTS

Refer to Fig. 2.1A.

This mower can be adjusted to cut from 1½" to 3½" high. Cutting heights should be determined by cutting conditions and personal preference. The following recommendations will provide a guide for height selection.

LAWNS..... 1½"-2½"

Due to the size of the mower, it is not recommended that the 1½" cutting height be used on any but the smoothest of lawns.

FIELD CUTTING..... 2½"-3½"

To change from one cutting height to another slide handle out of notch and move lever to desired notch.

The length of grass being removed should be no more than ⅓ of the height of the grass before it is cut. Tall grass will have to be cut twice for best results.

CUTTING SPEED

For best mowing results, it is important that blades be run at maximum speed. Set engine speed control in FAST position, thus providing proper blade speed and maximum engine horsepower. Engage the attachment drive

Choose a ground speed which will provide the desired finish cut, will provide maximum operator comfort and will not overload the mower drive. A slower ground speed will provide a smoother operating machine.

WARNING

FAILURE TO FOLLOW SAFE OPERATING PROCEDURE MAY RESULT IN INJURY.

1. READ OPERATOR'S MANUAL
2. KNOW LOCATION AND FUNCTION OF ALL CONTROLS
3. BEFORE LEAVING OPERATOR'S POSITION
 - A. SET PARKING BRAKE
 - B. SHUT ENGINE OFF AND REMOVE KEY
4. WAIT FOR ALL MOVEMENT TO STOP BEFORE SERVICING MACHINE
5. DO NOT OPERATE MACHINE WHERE IT COULD TIP OR SLIP
6. IF MACHINE STOPS GOING UPHILL, DISENGAGE P.T.O. (ATTACHMENT DRIVE) AND BACK SLOWLY DOWN
7. LOOK TO REAR BEFORE BACKING UP
8. REMOVE OBJECTS THAT COULD BE THROWN BY ROTATING BLADES
9. NEVER CARRY CHILDREN. KEEP PEOPLE AND PETS A SAFE DISTANCE AWAY FROM MACHINE
10. KEEP GUARDS AND SAFETY DEVICES IN PLACE AND WORKING

REPLACEMENT MANUALS ARE AVAILABLE FROM YOUR DEALER

TR1059

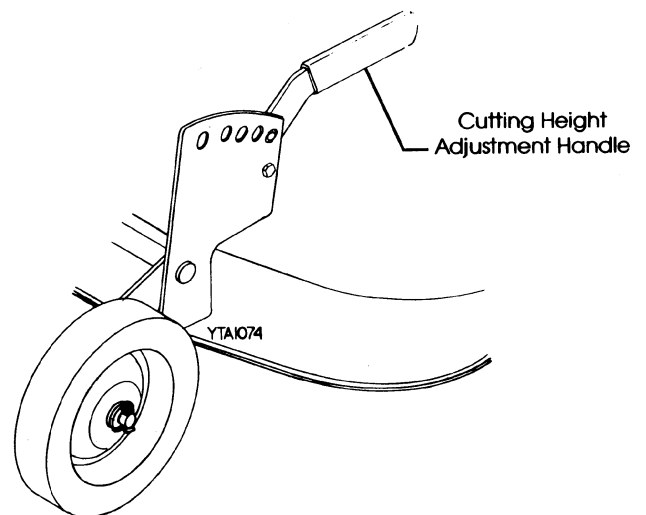

FIG. 2.1A

GRASS DISCHARGE

This mower was designed to provide a strong discharge to scatter clippings and prevent clogging in heavy cuttings. When cutting lush, thick, tall or wet grass shift to a slow ground speed setting and/or reduce width of cut to prevent possible belt damage. **FOR BEST CUTTING DO NOT MOW WHEN GRASS IS WET.** Wet grass will cause clogging and produce unsightly clumpings on lawn.



WARNING: To avoid personal injury from thrown objects, keep discharge guard down and secure at all times.



WARNING: To avoid personal injury from thrown objects, never allow mower to discharge in the direction of anyone.

IMPORTANT: The underside of mower deck should be cleaned out (sprayed with water) after each cutting with the engine stopped and blades not rotating.

In medium and heavy cuttings plan your mowing to discharge clippings away from uncut grass.

If mower becomes clogged, back unit out of uncut grass and try to clear deck by engaging the P.T.O. with the deck in the highest position. If deck does not clear itself turn engine off and wait for all movement to stop, remove spark plug wire(s) from spark plug(s) before cleaning underside of deck with a stick or scraper. If grass build-up is excessive remove mower from tractor and clean underside of deck thoroughly.

CUTTING PATTERNS

1. Cut counterclockwise patterns, to discharge grass into already cut areas (Fig. 2.2A).
2. Changing direction wastes time. Plan to keep mower moving forward as much as possible (Fig. 2.2A left).
3. Plan for the longest straight runs that are possible (Fig. 2.2A left).
4. Save the close trimming for the end.
5. Sometimes it is easier to divide a large irregular shaped area into smaller sections (Fig. 2.2A center) to keep the mower working more steadily or to keep from reversing, turning or repeating too often.
6. In a small area, where tight turns would cause lost time in the center if the normal round and round methods were used, try the cutting method in Fig. 2.2A right. Make the second pass down the center of the area rather than down the opposite side from the pass. This allows you to swing wide at the end of each pass and still cut all the grass with a minimum of reversing.

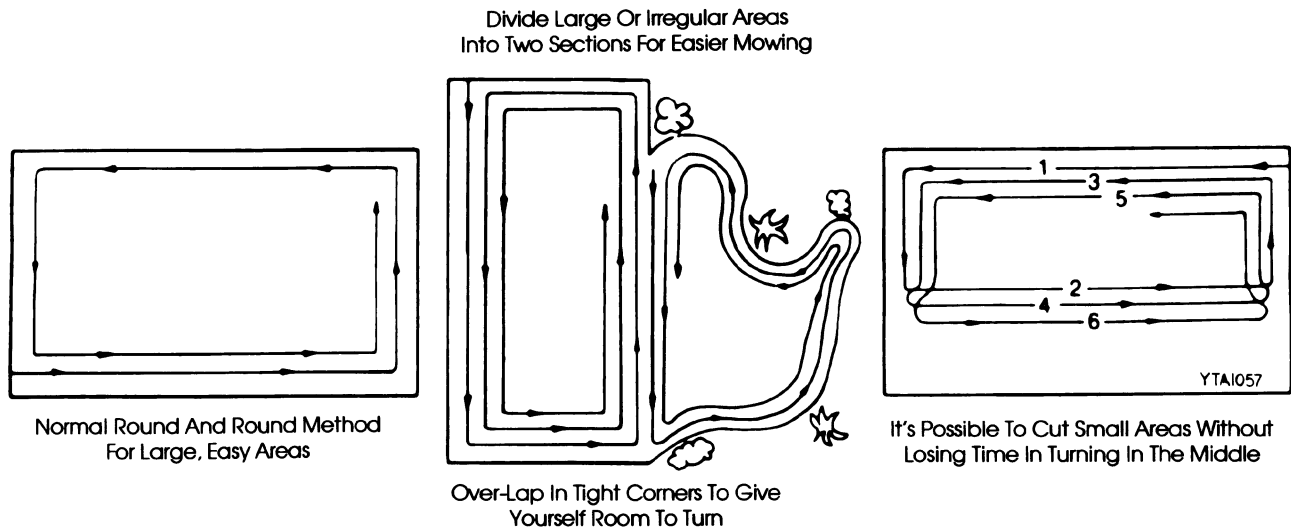

FIG. 2.2A

Thank you so much for reading.
Please click the “Buy Now!”
button below to download the
complete manual.



After you pay.

You can download the most
perfect and complete manual in
the world immediately.

Our support email:

ebooklibonline@outlook.com