

38" Twin Bagger

for

Lawn & Garden Tractors

Model No. 79202 – 6900001 & Up

Model No. 99200 – 6900001 & Up

Model No. 9861905 – T6M0001 & Up

Operator's Manual

IMPORTANT: Read this manual carefully. It contains information about your safety and the safety of others. Become familiar with the controls and their proper use before you operate this product. Also read the safety and operating instructions in your tractor operator's manual.

Introduction

We want you to be completely satisfied with your new product, so feel free to contact your local Authorized Service Dealer for help with service, genuine replacement parts, or other information you may require.

Whenever you contact your Authorized Service Dealer or the factory, always know the model and serial numbers of your product. These numbers will help the Service Dealer or Service Representative provide exact information about your specific product. You will find the model and serial number plate located in a unique place on the product as shown below.

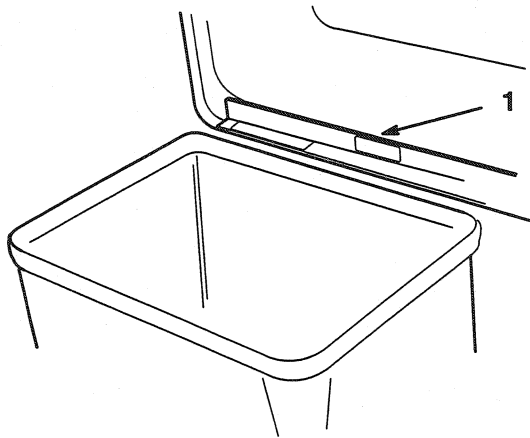

1375

1. Model and Serial Number Plate

For your convenience, write the product model and serial numbers in the space below.

Model No: _____
Serial No. _____

The warning system in this manual identifies potential hazards and has special safety messages that help you and others avoid personal injury, even death. **DANGER**, **WARNING** and **CAUTION** are signal words used to identify the level of hazard. However, regardless of the hazard, be extremely careful.

DANGER signals an extreme hazard that will cause serious injury or death if the recommended precautions are not followed.

WARNING signals a hazard that may cause serious injury or death if the recommended precautions are not followed.

CAUTION signals a hazard that may cause minor or moderate injury if the recommended precautions are not followed.

Two other words are also used to highlight information. "Important" calls attention to special mechanical information and "Note" emphasizes general information worthy of special attention.

The left and right side of the machine is determined by sitting on the seat in the normal operator's position.

Contents

	Page		Page
Safety and Instruction Decals	2	Emptying the Grass Bags	8
Installation	3	Clearing Obstructions From Bagger	9
Loose Parts	3	Operating and Bagging Tips	9
Assemble Bagger Cover	4	Maintenance	11
Tractor Set-Up	4	Inspecting the Bagger Attachment	11
Install the Twin Bagger	5	Inspecting the Mower Blades	11
Removing the Twin Bagger	7	Caring for the Grass Bags	11
Operation	8	Cleaning the Bagger Attachment	11
Using the Full Bag Tester	8	Storing the Bagger Attachment	12

Safety and Instruction Decals



Safety decals and instructions are easily visible to the operator and are located near any area of potential danger. Replace any decal that is damaged or lost.



ON BAGGER HINGE FRAME
(Part No. 92-7113)
(Part No. TR92D7113)



ON DISCHARGE ELBOW
(Part No. 93-1122)
(Part No. TR93D1122)

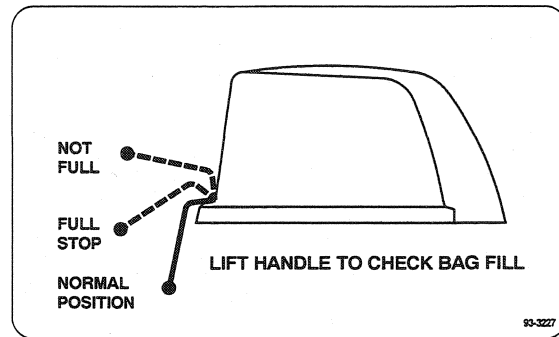

ON DISCHARGE ELBOW
(Model 9861905 only)
(Part No. 93-3227)
(Part No. TR93D1122)

Thank you so much for reading.
Please click the “Buy Now!”
button below to download the
complete manual.



After you pay.

You can download the most
perfect and complete manual in
the world immediately.

Our support email:

ebooklibonline@outlook.com