

ORIGINAL INSTRUCTIONS - according to Directive 2006/42/EC, Annex I 1.7.4.1

OPERATOR'S MANUAL

TD3.50

Tractors

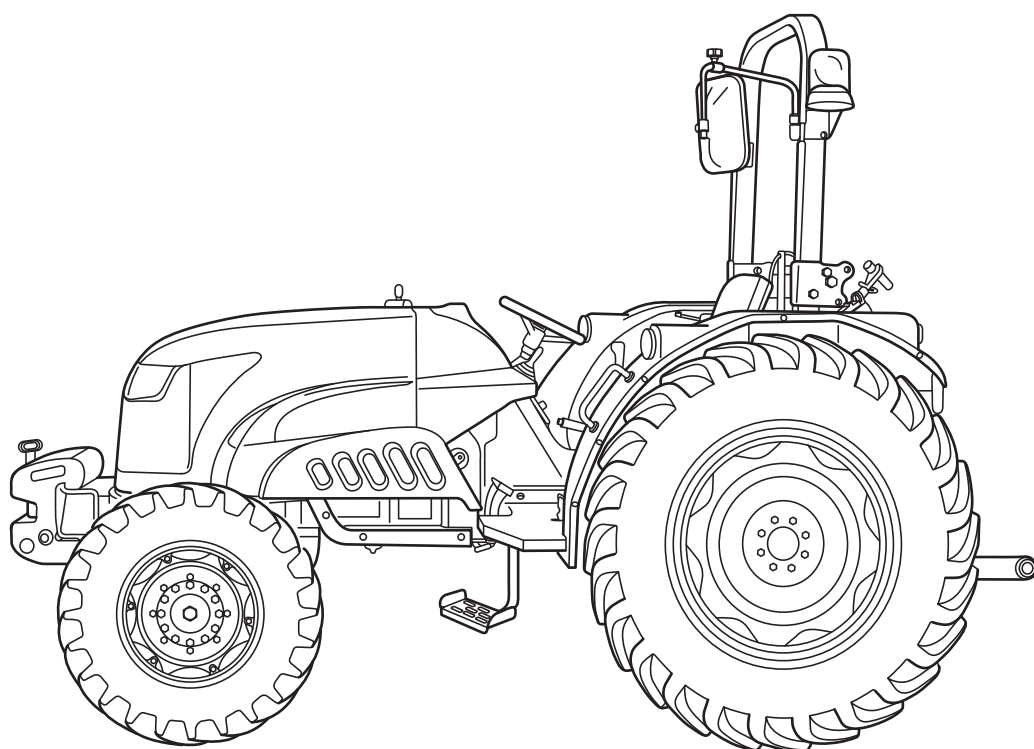

Part Number 47376814

1st edition English
May 2012



SECTION SUMMARY

- 1 – Introduction and safety measures**
- 2 – General information, controls and instruments**
- 3 – Field Operations**
- 4 – Lubrication and Maintenance**
- 5 – Troubleshooting**
- 6 – Vehicle storage**
- 7 – Accessories**
- 8 – Specifications and Data**
- 9 – First 50–Hour Service Forms**
- 10 – Alphabetical Index**

Electro-magnetic Interference (EMC)

This tractor complies with the European Regulations on electro-magnetic emissions. However, interference may arise as a result of add-on equipment which may not necessarily meet the required standards. As such interference can result in serious malfunction of the unit and/or create unsafe situations, you must observe the following:

... Ensure that each piece of non-New Holland equipment fitted to the tractor bears the CE mark.



... The maximum power of emission equipment (radio, telephones, etc.) must not exceed the limits imposed by the national authorities of the country where you use the tractor.

... The electro-magnetic field generated by the add-on system should not exceed 24 V/m at any time and at any location in the proximity of electronic components.

Failure to comply with these rules will render the New Holland warranty null and void.

For your better and easier understanding of the document you will find original text reproduced hereafter together with some notes

Clause of 2006/42/EC Annex II	EN EC Declaration of Conformity According to Directives 2006/42/EC
1.A.1	We, [1]
1.A.2	Represented by Giuseppe Gavioli, CNH Europe Holding S.A. 24, Boulevard Royal L-2449 Luxembourg
1.A.3	declare under our sole responsibility, that the product: Agricultural tractor Trade Name: [2] Model: [3] Type: [4] Serial Number: [5]
1.A.4	to which this declaration relates, fulfills all the relevant provisions of Directives 2006/42/EC amended by: [6]
1.A.7	For the relevant implementation of the provisions of the Directives, the following (harmonised) standards have been applied: ... ISO 26322-1 part 1 or 2 ... Other standards: see Operator's Manual
1.A.9	Place and date of the declaration: [7]
1.A.10	Name and signature of the authorised person: [8]

CONTENTS

Title	Page
CE DECLARATION OF CONFORMITY DOCUMENT	I
HEALTH AND SAFETY RELATED STANDARDS APPLIED TO YOUR TRACTOR	III
Section 1 - Introduction and Safety Measures	
To the owner	1-1
Tractor identification	1-3
Ecology and the environment	1-4
Safety messages used in this Manual	1-5
Working safely	1-12
Safety decals	1-27
International symbols	1-33
Section 2 - General Information, Controls and Instruments	
Safety covers and guards	1-31
Controls and instruments	2-2
Instrument panel	2-3
Instrument console controls	2-9
Right-hand side operating controls	2-10
Left-hand side operating controls	2-11
Seats	2-14
Transmission with range gear and shuttle	2-16
Towing the tractor	2-20
Loading the tractor onto a transporter	2-20
Checks before using the tractor	2-21
Section 3 - Field Operations	
Starting the engine with thermostart	3-3
Power take-off	3-5
Hydraulic lift	3-10
Three-point linkage Cat. II	3-21
Remote control valves	3-18
Wheel track adjustment	3-26
Tyres	3-29
Tyre combinations	3-32
Ballasting	3-34
Static weight distribution	3-39

Section 4 - Lubrication and Maintenance	
Access for inspection and maintenance	4-5
Lubrication and maintenance table	4-5
Flexible maintenance	4-8
When the warning light is on	4-10
10-hour / daily service	4-15
50-hour service	4-16
300-hour service	4-18
600-hour service	4-22
1200-hour service	4-24
1200-hour or every 2 years service	4-25
General maintenance	4-30
Electrical system	4-31
Recommendations for bodywork maintenance	4-37
Lubricant capacities and specifications	4-38
Section 5 - Troubleshooting	
Introduction	5-1
Engine	5-2
Electrical system	5-5
Hydraulic system	5-6
Three-point linkage	5-7
Brakes	5-8
Section 6 - Vehicle Storage	6-1
Section 7 - Accessories	
Beacon lamp	7-2
Drawbars and towing attachments	7-3
Section 8 - Specifications and Data	
General Dimensions	8-2
Weights	8-3
Engine specifications	8-5
Timing	8-6
Fuel system	8-6
Lubrication	8-7
Cooling system	8-7
Transmission	8-7
Power take-off	8-8
Hydraulic system	8-8
Three-point linkage	8-9
Front axle	8-9
Steering	8-10
4WD front axle	8-10
Brakes	8-11
Bodywork and driving position	8-11
Towing devices	8-11
Electrical system	8-12
Section 9 - First 50-hour Service Forms	9-1
Section 10 - Alphabetical Index	10-1

**METRIC AND IMPERIAL UNITS
ABBREVIATIONS**

TYPICAL APPLICATIONS	RECOMMENDED SI (METRIC) UNITS		IMPERIAL UNIT	
	NAME	SYMBOL	NAME	SYMBOL
AREA				
Land area	hectare	ha	acre	ha
	square meter	m ²	square foot	ft ²
	square millimetre	mm ²	square inch	in ²
ELECTRICITY				
	ampere	A	ampere	A
	volt	V	volt	V
	microfarad	µF	microfarad	µF
	ohm	Ω	ohm	Ω
FORCE				
	kilonewton	kN	pound	lb
	Newton	N	pound	lb
FORCE PER LENGTH				
	Newton per meter	N/m	pound per inch	lb/in
FREQUENCY				
	megahertz	MHz	Megahertz	MHz
	kilohertz	kHz	kilohertz	kHz
	hertz	Hz	hertz	Hz
FREQUENCY - ROTATIONAL				
	revolution per minute	r/min rpm	revolution per minute	r/min ^(a) rpm
LENGTH				
	kilometer	km	mile	mi
	meter	m	foot	ft
	centimeter	cm	inch	in
	millimeter	mm	inch	in
	micrometer	µm		
MASS				
	kilogram	kg	pound	lb
	gram	g	ounce	oz
	milligram	mg		

TYPICAL APPLICATIONS	RECOMMENDED SI (METRIC) UNITS		IMPERIAL UNIT	
	NAME	SYMBOL	NAME	SYMBOL
POWER				
	kilowatt	kW	horsepower	Hp
	watt	W	Btu per hour Btu per minute	Btu/hr Btu/min
PRESSURE or STRESS (FORCE PER AREA)				
	kilopascal	kPa	pound per square inch inch of mercury	PSI inHg
	pascal	Pa	inch of water	inH ₂ O
	megapascal	Mpa	pound per square inch	PSI
TEMPERATURE (other than THERMODYNAMIC)				
	degrees Celcius	-C	degrees Fahrenheit	-F
TIME				
	hour	h	hour	h
	minute	min	minute	min
	second	s	second	s
TORQUE (includes BENDING MOMENT, MOMENT OF FORCE, and MOMENT OF A COUPLE)				
	Newton meter	N m N m	pound foot pound inch	lb ft lb in
VELOCITY				
	kilometre per hour	km/h	mile per hour	mph
	meter per second	m/s	foot per second	ft/s
	millimetre per second	mm/s	inch per second	in/s
	meter per minute	m/min	foot per minute	ft/min
VOLUME (includes CAPACITY)				
	cubic meter	m ³	cubic yard	yd ³ cu yd
	litre	l	cubic inch	in ³
	litre	l	US gallon	US gal
			UK gallon	UK gal
			US quart	US qt
			UK quart	UK qt
	millilitre	ml	fluid ounce	fl oz

TYPICAL APPLICATIONS	RECOMMENDED SI (METRIC) UNITS		IMPERIAL UNIT	
	NAME	SYMBOL	NAME	SYMBOL
VOLUME PER TIME (includes DISCHARGE and FLOW RATE)				
	cubic meter per minute	m ³ /min	cubic foot per minute	ft ³ /min
	litre per minute	l/min	US gallon per minute	US gal/min
	millilitre per minute	ml/min	UK gallon per minute	UK gal/min
SOUND POWER LEVEL and SOUND PRESSURE LEVEL				
	decibel	dB	decibel	dB

SECTION 1

INTRODUCTION AND SAFETY MEASURES

TO THE OWNER

GENERAL

This Manual has been prepared to assist you in the correct procedure for running-in, driving and operating and for the maintenance of your new tractor. Read this Manual carefully. Your tractor is intended for use in normal and customary agricultural applications.

If at any time you require advice concerning your tractor, do not hesitate to contact your New Holland dealer. He has factory trained personnel, genuine manufacturers' parts and the necessary equipment to carry out all your service requirements.

Your tractor has been designed and built to give maximum performance, economy and ease of operation under a wide variety of operating conditions. Prior to delivery, the tractor was carefully inspected, both at the factory and by your dealer to ensure that it reaches you in optimum condition. To maintain this condition and ensure trouble-free operation, it is important that the routine services, as specified in Section 4 of this Manual, are carried out at the recommended intervals.

CLEANING THE TRACTOR

Your tractor is a state-of-the-art machine with user friendly controls. This should be borne in mind when cleaning the tractor, particularly if using a high pressure washer. Even though every precaution has been taken to safeguard electrical components and connections, the pressure generated by some of these machines is such that complete protection against water ingress can not be guaranteed.

When using a high pressure washer, do not stand too close to the tractor and avoid directing the jet at electronic components, electrical connections, breathers, seals, filler caps, etc. Never direct a cold water jet at a hot engine or exhaust.

SAFETY

Pages 1–5 to 1–25 inclusive list the precautions to be observed to ensure your safety and the safety of others. Read the safety precautions and follow the advice offered **before** operating the tractor.

FIRST 50 HOUR SERVICE

In Section 9, at the back of this Manual, you will find the 50-hour service reports.

After you have operated the tractor for 50 hours, take your tractor, together with this Manual, to your dealer. He will then perform the factory recommended 50-hour service and complete the service report sheets (pages 9–1 and 9–3). The first sheet (page 9–1) is the dealer's copy and should be removed by the dealer after the service has been carried out. The second sheet (page 9–3) is your copy of the service performed. **Ensure that you and the dealer sign both copies.**

SERVICE PARTS

It should be pointed out that genuine parts have been examined and approved by the Company. The installation and/or use of 'non-genuine' products could have negative effects upon the design characteristics of your tractor and thereby affect its safety. The Company is not liable for any damage caused by the use of 'non-genuine' parts and accessories. Only genuine replacement parts should be used. The use of non-genuine parts may invalidate legal approvals associated with this product.

It is prohibited to carry out any modifications to the tractor unless specifically authorised, in writing, by the After Sales Service department of the Company.

WARRANTY

Your tractor is warranted according to legal rights in your country and the contractual agreement with the selling dealer. No warranty shall, however, apply if the tractor has not been used, adjusted and maintained according to the instructions given in the Operator's Manual.

ABOUT THIS MANUAL

This Manual gives information for use of this tractor, as intended and under the conditions foreseen by the manufacturer during normal operation and routine service and maintenance.

- Normal operation means the use of the tractor for the purpose intended by the manufacturer by an operator familiar with the tractor and the mounted or towed equipment and complying with the information for operation and safe practices, as specified by the manufacturer in this Manual and by the signs on the tractor and the equipment.
- Normal operation includes the preparation and storage of the tractor, swinging components into work position and vice versa, adding or removing ballast and picking up and setting off attachments.
- Normal operation includes the adjustment and setting of the tractor and equipment, for the specific condition of the field and/or the crop.
- Routine service and maintenance means activities that must be done daily by an operator familiar with the tractor characteristics and complying with the information for routine service and safe practices, as specified by the manufacturer in this Manual and by signs on the tractor, in order to maintain its proper function. Routine service includes activities such as fuelling, cleaning, washing, topping up fluid levels, greasing, replacing of consumable articles such as lamp bulbs.
- This Manual is not giving all the information related to periodical service, converting and repairs to be carried out by professional service personnel. For some of the latter activities, there may be a need for appropriate facilities, technical skills and tools which are not supplied with the tractor, please refer to your dealer or authorised workshop.
- Periodical service means activities that must be done at defined intervals by trained personnel familiar with the tractor characteristics and which are complying with the information for periodical service and safe practices, as partly specified by the manufacturer in this Manual and in other Company literature, in order to maintain the expected life time of the tractor.
- Converting means activities that must be done by professional service personnel familiar with the tractor characteristics and complying with the information for converting, as partly specified by the manufacturer in this Manual, in assembly instructions or in other Company literature, in order to fit the tractor to a specific configuration.
- Repair means activities that must be done by professional service personnel only familiar with the tractor characteristics and complying with the information for repair, as specified by the manufacturer in the dealer's Workshop Manual, in order to restore the proper function of the tractor after a failure or degradation of performance.

TRACTOR IDENTIFICATION PLATES

Serial numbers identify the tractor and its main components. The identification data must be supplied by the dealer for requests for spare parts or service operations. Identification data is of fundamental importance in the event of theft of the tractor. The location of the various identification data is shown below.

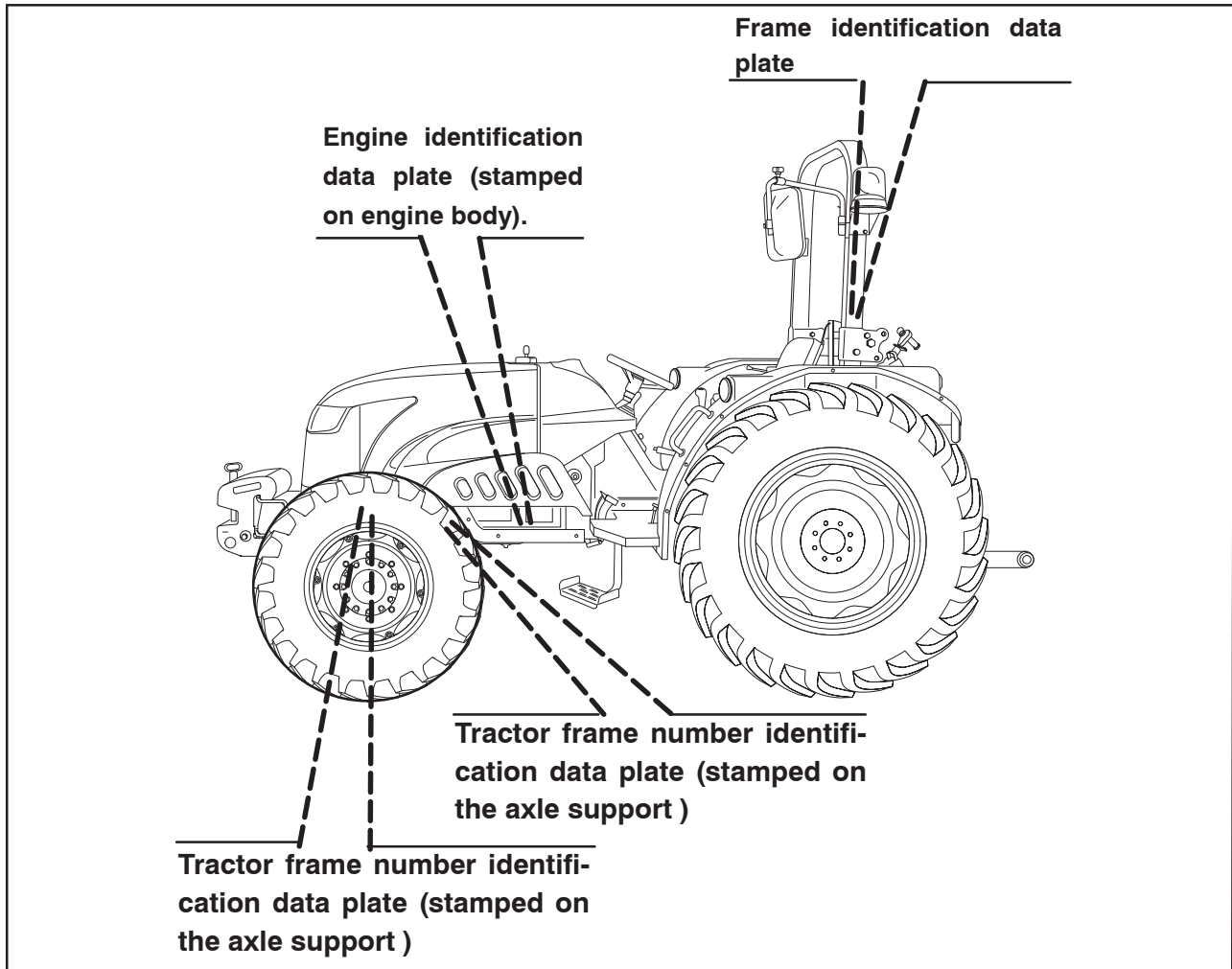

Frame identification data plate

The Product Identification Number plate provides important information on tractor and towed equipment weight combinations. This plate can be found on the left-hand side of the rops support.

The figures shown are the maximum permissible vehicle and towing weights and should not be exceeded, to do so may affect the safe operation of the tractor. See Drawbars and Towing Attachments in Section 7.

CNH EUROPE HOLDING S. A.	
TYPE	:
HOMOLOGATION	:
IDENTIFICATION	:
WEIGHTS (Kg)	
TOTAL PERMISSIBLE MASS	[]
PERMISSIBLE FRONT AXLE LOAD	[]
PERMISSIBLE REAR AXLE LOAD	[]
PERMISSIBLE TOWABLE MASS	
- UNBRAKED TOWABLE MASS	[]
- INDEPENDENTLY BRAKED TOWABLE MASS	[]
- INERTIA-BRAKED TOWABLE MASS	[]
- TOWABLE MASS FITTED WITH AN ASSISTED BRAKING SYSTEM	[]
Made in Turkey	

Thank you so much for reading.
Please click the “Buy Now!”
button below to download the
complete manual.



After you pay.

You can download the most
perfect and complete manual in
the world immediately.

Our support email:

ebooklibonline@outlook.com