

ORIGINAL INSTRUCTIONS

Steiger® 400
Steiger® 450
Steiger® 500
Steiger® 550
Steiger® 600
Quadtrac® 450
Quadtrac® 500
Quadtrac® 550
Quadtrac® 600
Tier 2
Tractor

PIN JEEZ00000FF314001 and above

OPERATOR'S MANUAL

Part number 47739259

1st edition English

September 2017



Contents

1 GENERAL INFORMATION

Note to the owner.....	1-1
Intended use.....	1-1
CNH Industrial America LLC technical manuals	1-2
Your tractor	1-3
Electro-Magnetic Compatibility (EMC)	1-5
Product identification	1-6
Operator's manual storage on the machine	1-9
Machine orientation.....	1-10
Component location	1-12

2 SAFETY INFORMATION

Safety alert symbol and signal word definition	2-1
Safety rules.....	2-2
Ecology and the environment	2-13
Protective structures.....	2-14
Hazardous substances	2-15
Emergency exit	2-16
Articulation cylinder locking blocks	2-17
Safety signs	2-18

3 CONTROLS AND INSTRUMENTS

Access to operator's platform

Cab access/exit.....	3-1
----------------------	-----

Operator's seat

Overview	3-2
Control identification.....	3-4

Instructional seat

Overview	3-7
----------------	-----

Forward controls

Steering column controls	3-8
Front console controls.....	3-11
Pedal controls	3-12
Ventilation	3-14
Front sun shade	3-15

Right-hand side controls

Armrest console	3-16
Multi-function handle	3-18
Minimum/maximum throttles - CVXDrive™ transmission	3-23
Control panel	3-24

Remote valve controls	3-31
Joystick	3-32
Armrest compartment	3-33
Adjusting the armrest console	3-35

Rearward controls

Rear sun shade	3-36
----------------------	------

Overhead controls

Overview	3-37
Automatic Temperature Control (ATC)	3-39
Automatic Temperature Control (ATC) operation	3-43
Center panel controls	3-45
Radio (if equipped)	3-50
Interior and access lights	3-51
Interior rear-view mirror	3-52

Exterior controls

Exterior hitch control	3-53
Outside extendable mirrors	3-53

Instrument cluster

Overview	3-54
Gauges	3-54
Status and warning icons	3-55
Upper display	3-58
Lower display	3-60
Keypad	3-62
Instrumentation - setup menu	3-63
Instrumentation - adjust menu	3-70
Performance instrumentation	3-76

4 OPERATING INSTRUCTIONS

Commissioning the unit

Before starting the engine	4-1
----------------------------------	-----

Starting the unit

Normal engine starting	4-5
Cold temperature operation	4-8

Stopping the unit

Stopping the machine and the engine	4-11
---	------

Moving the unit

Inching (clutch) pedal operation	4-12
Transmission control lever	4-13

Powershift transmission	4-15
Overview	4-15
Transmission controls	4-17
Driving the powershift transmission	4-18
Changing startup gear	4-21
Automatic Productivity Management (APM)	4-23
Ground Speed Management (GSM)	4-33
Continuously variable transmission	4-43
Overview	4-43
Foot pedal and hand throttle controls	4-45
Transmission controls	4-50
Driving the CVXDrive™ transmission	4-55
Transmission messages	4-63
All tractors	4-64
Electronic steering system	4-64
Differential lock system	4-65
Power management	4-68
Constant engine speed	4-69
Electronic end-of-row system	4-74
Engine compression brake (if equipped)	4-80

Parking the unit

Automatic park lock	4-81
---------------------------	------

5 TRANSPORT OPERATIONS

Road transport

Tractor warning lamps	5-1
Operating the tractor warning lamps	5-3
Safe transport speed	5-4
Implement warning lamps	5-5
Safety chain	5-5

Shipping transport

Securing the tractor for shipping	5-6
---	-----

Recovery transport

Safety rules	5-7
Towing the tractor	5-8

6 WORKING OPERATIONS

General information

Product overview	6-1
------------------------	-----

REAR POWER TAKE-OFF (PTO)

Power Take-Off (PTO) safety rules	6-2
Connecting the Power Take-Off (PTO)	6-3

Power take-off (PTO) operation	6-4
--------------------------------------	-----

THREE-POINT HITCH

Identification	6-8
Link adjustment	6-9
Sway block adjustment	6-12
Mechanical float adjustment	6-13
Hitch quick coupler - Category IVN	6-14
Transport lock	6-17
Hitch operation	6-18
Rear remote hitch switch	6-22
Position control operation	6-23
Slip control operation	6-26

DRAWBARS AND TOWING ATTACHMENTS

Safety rules	6-28
Drawbar capacities	6-29
Scraper operation	6-33

TRAILER BRAKE COUPLER

Safety rules	6-34
Trailer brake connections	6-34

AUXILIARY POWER CONNECTIONS

External power and lighting connections	6-35
Cab power connections	6-37

HYDRAULIC REMOTE CONTROL VALVES

Valve couplers and connections	6-40
Optional circuits	6-47
Hydraulic remote valve transport lock	6-48
Right-hand armrest controls	6-49
Operating the lever controls	6-50
Operating the Joystick control	6-54
Remote valve display screens	6-59
Auto auxiliary mode operation	6-62
Auto depth control operation	6-65

BALLASTING THE TRACTOR

Guidelines	6-68
Weights, cast metal and liquid	6-72
Wheel weight bolt torque	6-78
Wheel slip	6-79

FRONT AND REAR AXLE

Tire safety	6-80
-------------------	------

Pressure and load ratings	6-80
Wheel installation.....	6-88
Wheel tread settings on flange axles.....	6-96
Wheel tread settings on bar axles.....	6-97
Pre-conditioning rubber tracks	6-106

7 MAINTENANCE

General information

General information	7-1
Engine hood	7-2
Engine side shields.....	7-3
Opening the right-hand service door	7-4
Battery access.....	7-5
Power cut-off switch	7-6
Filling the fuel tank	7-8
Fuel tank capacity	7-9
Tire and rim service.....	7-10
Tractor jacking points.....	7-12
Lubricants and capacities	7-15
Engine oils.....	7-16
Consumables - Diesel fuel - Diesel fuel	7-17
Consumables - Biodiesel fuel - Biodiesel fuels	7-18
Organic Acid Technology (OAT) coolant.....	7-20
Electrical specifications.....	7-21
Battery system.....	7-22
Auxiliary battery connections	7-24
Engine hourmeter	7-26

Maintenance planning

Maintenance chart.....	7-27
------------------------	------

At warning message display

Air cleaner	7-29
Primary fuel filter	7-30
Fuel supply restricted (13L engines only)	7-30

Every 10 hours or daily

Engine oil level	7-31
Wheel bolt torque.....	7-31
Wheel weight bolt torque	7-31
Transmission oil level.....	7-32
Hydraulic and axle oil level	7-33
Engine coolant level	7-34
Fuel level	7-35
General tractor inspection	7-35

Every 50 hours

Fuel tank and fuel filter	7-36
---------------------------------	------

Articulation hinge - upper front	7-37
Oscillation hinge - rear	7-38
Articulation hinge - lower	7-38
Articulation cylinder - front, left-hand, right-hand	7-39
Articulation cylinder - rear, left-hand and right-hand	7-39
Hitch cylinder pin - upper (if equipped)	7-39
Hitch cylinder pin - lower (if equipped)	7-40
Hitch rockshaft - left-hand and right-hand	7-41
Hitch lift links and top link	7-41
Driveshaft carrier bearing	7-42

First 100 hours

Powershift transmission filter	7-43
Powershift transmission clutches	7-44
CVXDrive™ transmission filters	7-50
CVXDrive™ transmission clutches	7-51
Power Take-Off clutches on CVXDrive™ transmission	7-55
Engine fuel filter	7-60
Hydraulic oil filters	7-63

Every 600 hours

Engine oil and filter	7-64
Engine fuel filter	7-66
Engine fuel pre-filter	7-67
Fuel tank vent	7-71
Cab air filter, outside	7-72
Air tubing - engine	7-73
Alternator - water pump belt	7-73
Power Take Off (PTO) carrier bearing	7-74
Power Take Off (PTO) slip joint	7-74
Radiator and coolers	7-76
Saddle tanks	7-78
Cab recirculation filter	7-78

Every 600 hours or yearly

Battery electrolyte level	7-79
---------------------------------	------

Every 1000 hours or yearly

Powershift transmission clutches	7-80
--	------

Every 1200 hours

Engine crankcase breather filter	7-80
Powershift transmission oil and filter	7-82
Powershift transmission breather	7-83
CVXDrive™ transmission oil and filters	7-84
CVXDrive™ transmission clutches	7-86
CVXDrive™ transmission breather	7-86
Engine air filters	7-87

Door lock and hinges	7-93
----------------------------	------

Every 1800 hours

Hydraulic oil and filters	7-94
Hydraulic reservoir breather	7-96
Cab air filter, outside	7-97
Engine air tubing	7-98

Every 2400 hours

Engine coolant drain and flush	7-99
Idler and roller wheel oil	7-102

Every 3000 hours

Engine valve adjustment	7-103
-------------------------------	-------

As required

Power Take-Off clutches on CVXDrive™ transmission	7-103
Vehicle fire prevention	7-103
Remote valve couplers	7-104
Pressure cooling system hoses	7-104
Hydraulic system hoses	7-104
Tire pressure	7-104
Serpentine belt	7-105
Viscous fan drive	7-105
Track inspection and bolt torque	7-106
Track tension release	7-108
Track alignment	7-110
Cab fabric and carpet	7-112
Seat belt	7-112
Battery removal and installation	7-113
Flood and work lamps	7-115
Rotating beacon light	7-118
Exterior step light	7-118
Interior lights	7-120
Road lamps	7-123
Front amber turn and position lamps	7-125
Marker/position lamp	7-127
Rear amber turn/tail/stop lamps	7-128
License plate lamp	7-129

Fuse and relay locations

Component identification	7-130
--------------------------------	-------

Storage

Placing in storage	7-137
Removing from storage	7-138

8 TROUBLESHOOTING

Fault code resolution

Fault code retrieval	8-1
----------------------------	-----

Alarm(s)

Display warnings	8-3
Powershift transmission	8-12
Continuously variable transmission	8-14

9 SPECIFICATIONS

Engine specifications	9-1
Power train and hydraulics	9-3
Lubricants and capacities	9-6
Speed charts - powershift transmission	9-7
Speed charts - CVXDrive™ transmission	9-9
Vehicle dimensions and shipping weight	9-12
Maximum operating weight	9-16

10 ACCESSORIES

Farming system displays	10-1
Chemical tank mounting	10-2
General accessories	10-5

1 - GENERAL INFORMATION

Note to the owner

This manual contains important information about the safe operation, adjustment, and routine maintenance of your tractor. The manual is divided into ten chapters as outlined on the Contents page. Refer to the index at the end of this manual for locating specific items about your tractor.

Do NOT operate or permit anyone to operate or service this machine until you or the other persons have read this manual. Use only trained operators who have demonstrated the ability to operate and service this machine correctly and safely.

Store this operator's manual in the manual compartment behind the operator's seat in the vehicle. Make sure this manual is in good condition. Contact your dealer to obtain

additional manuals. Contact your dealer for any further information or assistance about your machine. Your dealer has approved service parts. Your dealer has technicians with special training that know the best methods of repair and maintenance for your tractor.

ATTENTION: *The engine and fuel system on your machine is designed and built to government emissions standards. Tampering by dealers, customers, operators and users is strictly prohibited by law. Failure to comply could result in government fines, rework charges, invalid warranty, legal action and possible confiscation of the machine until rework to original condition is complete. Engine service and/or repairs must be done by a certified technician only!*

Intended use

The intended use of **Steiger®**, and **Quadtrac®** series tractors with standard equipment and authorized attachments is for customary farming, land leveling, and related agricultural operations. Standard equipment includes rear-drawbar towed implements and hitch-mounted implements for tillage, planting, seeding, and hauling. You or a CASE IH authorized dealer must install attachments for agricultural liquid chemical application in a way that does not impair the safe operation of the tractor. Compliance with and strict adherence to the conditions of operation, service, and repair, as specified by CASE IH, and including conditions as to inspection, cleaning and maintenance, constitute essential elements of the intended use.

CASE IH does not intend for the use of this tractor for forestry work or with loaders. The cab on this tractor does not offer sufficient protection. CASE IH does not approve the installation or use of unauthorized frame-mounted or other attachments. No attachment should be used in a manner that would be ground engaging or for pushing anything other than loose material (i.e. silage, compost, snow). You or a CASE IH authorized dealer must install attachments in a way that does not impair the safe operation of the tractor. The tractor warranty will not cover any tractor damage that results from the installation and/or use of such equipment.

Consult an authorized CASE IH dealer or CNH Industrial America LLC on changes, additions, or modifications that this tractor may require to comply with various regulations and safety requirements. Unauthorized modifications will cause serious injury or death. Anyone who makes such unauthorized modifications is responsible for the consequences.

Only use this tractor in the manner described in the provided manuals, decals, and other product safety materials. These materials define the intended use of the tractor. CASE IH considers use in any other way as contrary to the intended use. CASE IH accepts no liability for any damage or injury that results from this misuse. The user must solely bear these risks.

All persons who will operate this tractor shall possess a valid local vehicle-operating permit and/or other applicable local age work permits.

All persons who operate, service, and repair this tractor must be familiar with all its particular characteristics, and understand the relevant safety rules.

Any arbitrary modifications carried out on the tractor will relieve CASE IH of all liability for any resulting damage or injury.

CNH Industrial America LLC technical manuals

Manuals are available from your dealer for your machine. Your dealer can expedite your order for operator manuals and parts catalogs.

Always give the machine name, model and Product Identification Number (PIN) of your machine so your dealer can provide the correct manuals for your machine.

The company is continually striving to improve its products and therefore reserves the right to make improvements and changes when it becomes practical and possible to do so, without incurring any obligation to make changes or additions to the equipment sold previously.

Manual scope and required training level

This manual provides information on the intended use of your tractor under the conditions foreseen by the manufacturer during normal operation, routine service and maintenance and periodic service and maintenance.

Normal operation is use of the tractor for the purpose intended by the manufacturer by an owner/operator who is familiar with the tractor and the mounted or towed equipment, and who is complying with the information on operation and safe practices, provided in this manual and by the decals on the tractor and the equipment.

Normal operation includes such actions as preparing the tractor for storage and removing the tractor from storage, adding or removing ballast, connecting and disconnecting mounted or towed equipment, raising and lowering components into or out of work position, adjusting tractor settings for specific field or crop settings, etc.

Routine service and maintenance are those actions which must be performed daily to maintain proper tractor function by an owner/operator who is familiar with tractor characteristics, and who is complying with the information on routine service and safe practices in this manual and in the decals on the tractor.

Routine service and maintenance includes such actions as fueling, cleaning, washing, topping off fluid levels, greasing, and replacing consumable articles such as lamp bulbs.

Periodic service and maintenance are those actions which must be performed at regularly defined intervals

All data given in this manual is subject to production variations.

NOTICE: *Operating and service messages displayed on the electronic operating panel may vary from what is shown in the manual. If this occurs, heed the latest instructions on the electronic operating panel.*

Dimensions and weights are approximate only and the illustrations do not necessarily show the machine in standard condition. For exact information about any particular machine, please consult your dealer.

to maintain proper tractor function by an owner/operator who is familiar with tractor characteristics, and who is complying with the information on periodic service and safe practices in this manual and in the decals on the tractor.

Periodic service and maintenance includes such actions as checking, cleaning and changing air filters, changing engine oil and filters, changing transmission oil and filters, changing front axle and wheel hub fluids, changing coolant, etc.

Some actions in the periodic service and maintenance chart are beyond the knowledge and skills of the owner/operator: for example, engine valve adjustment, fuel injector nozzles. For these actions, the manual instructs the owner/operator to have the action performed by their authorized dealer.

This manual does not contain all the information related to periodical service and maintenance, converting and repairs to be carried out by professional service personnel. These actions require special facilities, technical skills, and/or tools which are not supplied with the machine.

Converting is changing the tractor configuration for a specific crop or soil condition and requires rebuilding or adding components to the vehicle: for example, installation of dual wheels. Repairing is the disassembly and assembly of the tractor to restore proper operation after a component failure or degradation of performance.

Your tractor

This manual covers the **Steiger®** 400, 450, 500, 550, 600, and **Quadtrac®** 450, 500, 550, 600 models.

References are made within this manual of “row crop models” and “high power models”.

Row crop models include **Steiger®** 400, and 450 models.

High power models include **Steiger®** 500, 550, 600 and all **Quadtrac®** models.

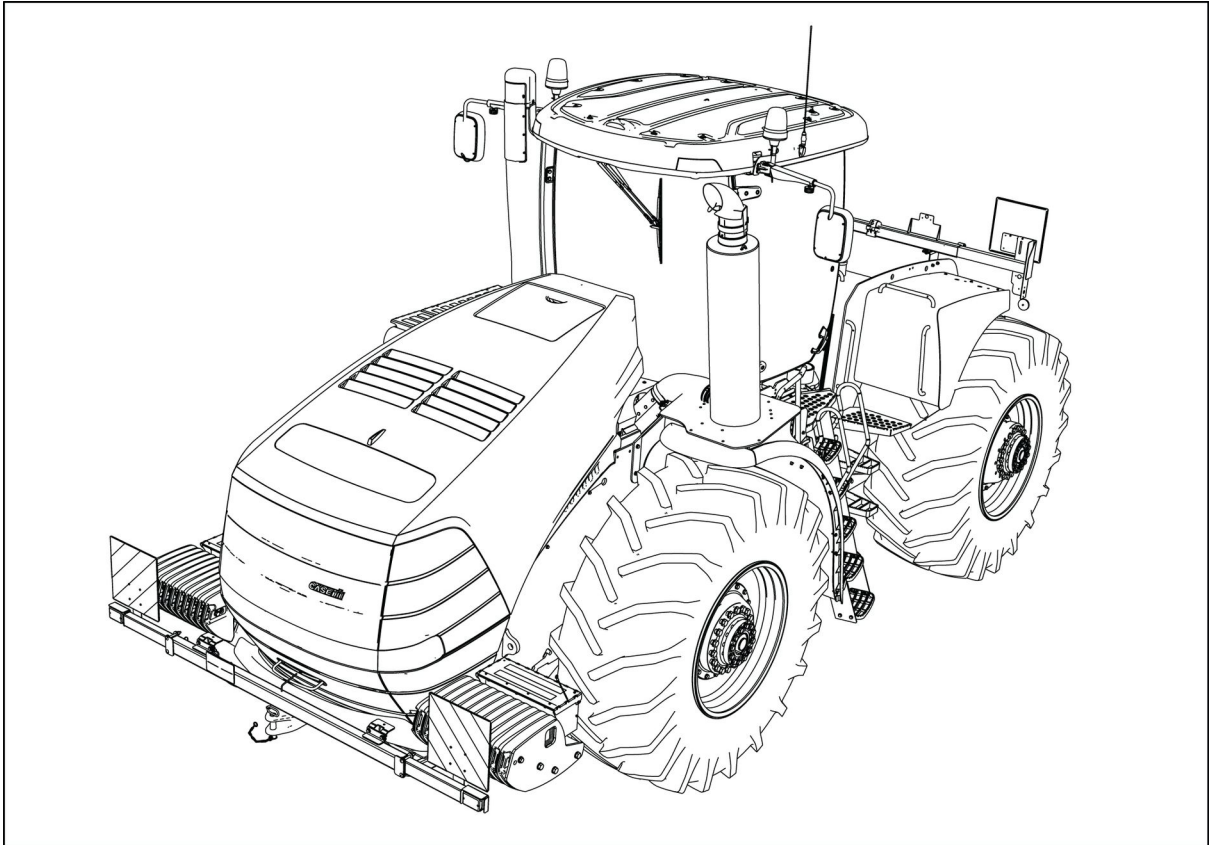

RAIL13TR03681FA 1

Steiger® models

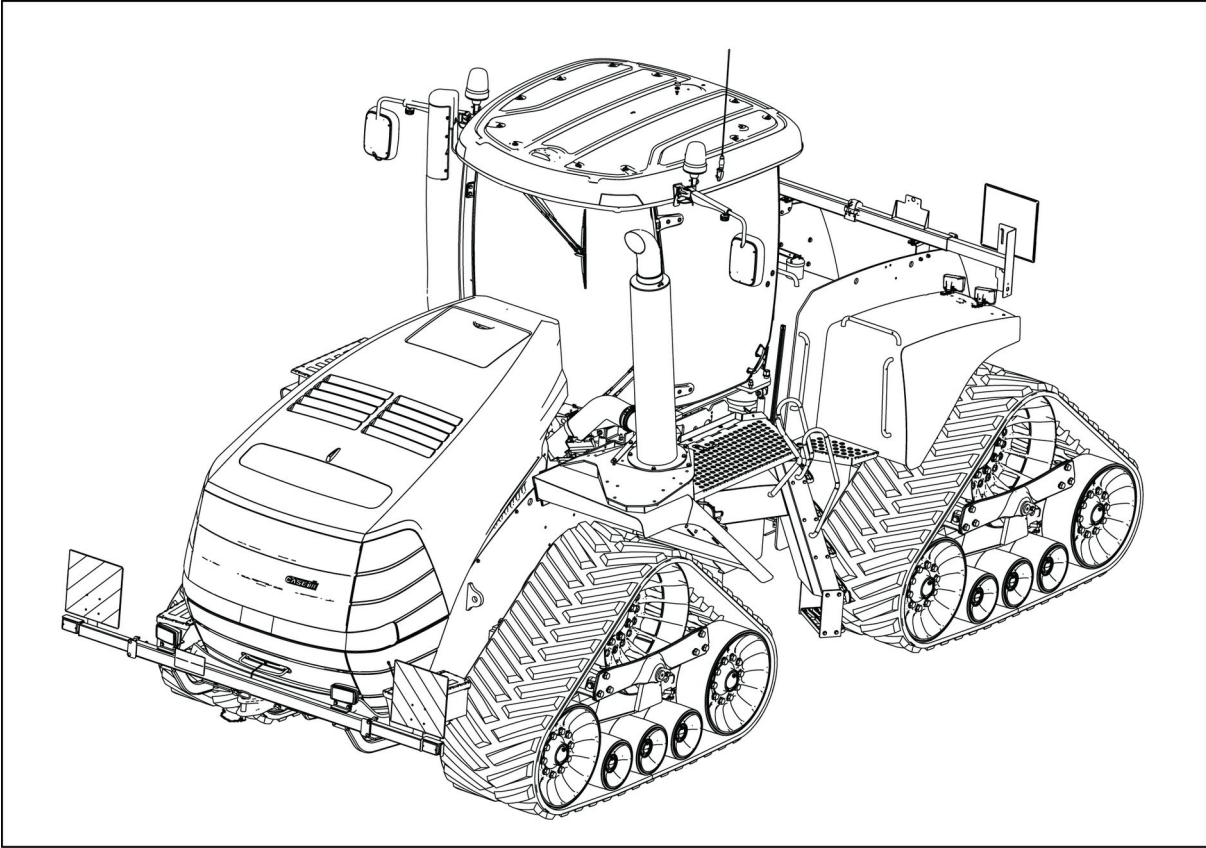

RAIL15TR00817FA 2

Quadtrac® models

Buy Now



Our support email:

ebooklibonline@outlook.com