

# OPERATOR'S MANUAL

---

**Boomer™ 46D CVT**

**Boomer™ 54D CVT**

**Tier 4B (final)**

**Compact Tractor**

**Part number 48028213**

3<sup>rd</sup> edition English

March 2017

*Replaces part number 47911419*



# Contents

---

## 1 GENERAL INFORMATION

Note to the owner.....	1-1
Intended use.....	1-2
Electro-Magnetic Compatibility (EMC) .....	1-4
Product Identification Number (PIN).....	1-5
Operator's manual storage on the machine .....	1-7
Machine orientation.....	1-8
Exhaust Gas Recirculation (EGR) exhaust treatment - Product overview .....	1-10

## 2 SAFETY INFORMATION

Safety alert symbol and signal word definition .....	2-1
Safety rules .....	2-2
Roll Over Protective Structure (ROPS) .....	2-9
Ecology and the environment .....	2-10
Safety features .....	2-11
Safety signs .....	2-12
Instructional signs .....	2-21
International symbols.....	2-28

## 3 CONTROLS AND INSTRUMENTS

### ACCESS TO OPERATOR'S PLATFORM

Doors .....	3-1
-------------	-----

### OPERATOR'S SEAT

Operator's seat .....	3-2
Seat belt .....	3-3
Roll Over Protective Structure (ROPS) .....	3-4

### FORWARD CONTROLS

Steering wheel.....	3-6
Instrument panel.....	3-7
Analog Digital Instrument Cluster (ADIC) programming.....	3-13
Analog Digital Instrument Cluster (ADIC) fault codes - Transmission and PTO related .....	3-26
Analog Digital Instrument Cluster (ADIC) fault codes - Engine related .....	3-28
Status and warning icons.....	3-33
Particulate Matter Catalyst .....	3-36
Hand throttle lever .....	3-41
Transmission shuttle shift lever.....	3-42
Multifunction light switch.....	3-42
Hazard lights switch .....	3-43
Work lights switch .....	3-44

---

## LEFT-HAND SIDE CONTROLS

Continuously Variable Transmission (CVT) controls .....	3-45
Four-Wheel Drive (4WD) control switch .....	3-50
Differential lock pedal.....	3-51

## RIGHT-HAND SIDE CONTROLS

Speed control pedal .....	3-52
Power Take-Off (PTO) controls.....	3-53
Hydraulic power lift (HPL) .....	3-56
Rear remote control valve(s) .....	3-56
Mid mount two spool control valve .....	3-56

## REARWARD CONTROLS

Rear window.....	3-57
Auxiliary power outlet.....	3-57
Rear window wiper/washer (optional) .....	3-58

## OVERHEAD CONTROLS

Cab climate control - Overview .....	3-59
Air conditioning .....	3-60
Sun shades.....	3-64
Cab internal lighting .....	3-64
Cab external lighting .....	3-65
Front window wiper/washer .....	3-67

## EXTERIOR CONTROLS

Hood latch .....	3-68
Rear-view outside mirrors .....	3-68
Tool box.....	3-69

## 4 OPERATING INSTRUCTIONS

### COMMISSIONING THE UNIT

CVT transmission controls (standard user interface) - settings and adjustments .....	4-1
CVT transmission controls (enhanced user interface) - settings and adjustments .....	4-7
Suggested operating mode settings - Basic user interface .....	4-18
Suggested operating mode settings - Enhanced user interface .....	4-20
Power Take-Off (PTO) operation .....	4-22
Extendable drawbar .....	4-23
Deluxe three-point linkage.....	4-25

### STARTING THE UNIT

Engine pre-heat system .....	4-26
Starting the engine .....	4-27
Starting the tractor with jumper cables .....	4-29
Low ambient temperature tractor warm up.....	4-30

---

## STOPPING THE UNIT

Stopping the engine .....	4-32
Brakes .....	4-32
Park brake .....	4-33

## 5 TRANSPORT OPERATIONS

### ROAD TRANSPORT

Front work and road lights .....	5-1
Hazard lights .....	5-5
Tail/brake lights .....	5-7
Cab work lights .....	5-10
Roof beacon (optional) .....	5-11
Multifunction stalk switch .....	5-12

### RECOVERY TRANSPORT

Preparation for towing .....	5-13
------------------------------	------

## 6 WORKING OPERATIONS

### GENERAL INFORMATION

Filling the fuel tank .....	6-1
Engine - Running-in Procedure .....	6-2
Driving the tractor .....	6-2

### Tractor hydraulics

Hydraulic systems - Safety rules .....	6-3
Hydraulic power lift (HPL) .....	6-3
Position control .....	6-5
Top link lift rocker .....	6-5
Hydraulic power lift (HPL) drop rate control valve .....	6-5
Rear remote control valve(s) .....	6-6
Mid mount two spool control valve .....	6-7

## 7 MAINTENANCE

### GENERAL INFORMATION

General information .....	7-1
Torque - Minimum tightening torques for normal assembly .....	7-3
Exhaust Gas Recirculation (EGR) exhaust treatment - Product overview .....	7-5
Diesel fuel .....	7-8
Biodiesel fuel .....	7-9
Organic Acid Technology (OAT) coolant .....	7-11
Fluids and lubricants .....	7-12
Capacities .....	7-12
Jacking points .....	7-13

### MAINTENANCE CHART

Maintenance chart .....	7-14
-------------------------	------

---

## Every 10 hours or daily

Engine oil level .....	7-15
Engine coolant level .....	7-16

## After first 50 hours

Engine oil and filter .....	7-17
Wheels bolt/nut .....	7-19
Roll Over Protective Structure (ROPS) .....	7-20

## Every 50 hours

Lubrication points.....	7-21
Transmission oil level.....	7-23
Brake pedal free play.....	7-23
Engine belts .....	7-26
Tires .....	7-27
Front axle (4WD) oil level.....	7-29

## Every 100 hours

Air cleaner primary element .....	7-31
Cab air filter.....	7-32
Engine and transmission coolers.....	7-33

## Every 300 hours

Engine oil and filter .....	7-35
Hydraulic suction strainer.....	7-35
Hydraulic system pressure filter .....	7-36
Steering system pressure filter .....	7-37
Transmission control valve filter .....	7-38

## Every 600 hours

Gerotor pump inner filter cleaning .....	7-39
Pre-fuel filter.....	7-40
Fuel filter.....	7-41
Transmission fluid .....	7-42
Front axle (4WD) oil .....	7-42

## Every 1000 hours

Air cleaner safety element Inner safety element .....	7-45
Cab air filter.....	7-46
Engine coolant.....	7-47

## General maintenance

Seat belt .....	7-49
Fuses .....	7-50
Battery.....	7-54

---

Headlight .....	7-55
Taillight .....	7-56
Turn signal/hazard light bulb .....	7-58
Cab Work Lights .....	7-61
Brake pedal free play .....	7-62
Park brake .....	7-62
Windshield wiper fluid reservoir .....	7-63
Steering stop bolts .....	7-63
Front wheel toe-in .....	7-64

## STORAGE

Storing the tractor .....	7-65
Removal of tractor from storage .....	7-66

## 8 SPECIFICATIONS

Wheel tread settings .....	8-1
Tractor weighting .....	8-2
General specifications .....	8-3
Tractor dimensions .....	8-9

## 9 ACCESSORIES

Front end weights .....	9-1
Rear wheel weights .....	9-2
3-point hitch counter weight .....	9-3
Rear wheels liquid ballast .....	9-4
Tire inflation pressures .....	9-4
Dealer installed accessory (DIA) .....	9-5
Dealer installed winter packages .....	9-6

## 10 FORMS AND DECLARATIONS

Delivery report - owner copy .....	10-3
Delivery report - dealer copy .....	10-5

# 1 - GENERAL INFORMATION

## Note to the owner

This manual contains information concerning the adjustment and maintenance of your new equipment. You have purchased a dependable machine, but only by proper care and operation can you expect to receive the performance and long service built into this equipment. Please have all operators read this manual carefully and keep it available for ready reference.

Your NEW HOLLAND dealer will instruct you in the general operation of your new equipment. (Refer to the 'Delivery Report' at the back of this manual.) Your dealer's staff of factory-trained service technicians will be glad to answer any questions that may arise regarding the operation of your machine. New Holland Top Service is also available. Call 1-866-NEWHLND (1-866-639-4563) or email [na.topservice@cnh.com](mailto:na.topservice@cnh.com).

Your NEW HOLLAND dealer carries a complete line of genuine NEW HOLLAND service parts. These parts are manufactured and carefully inspected to insure high quality and accurate fitting of any necessary replacement parts. Be prepared to give your dealer the model and product identification number of your new equipment when ordering parts. Locate these numbers now and record them below. Refer to the 'General Information' section of this manual for the location of the model and product identification numbers of your machine.

### PLEASE RECORD THE FOLLOWING INFORMATION

Model

---

Product Identification Number (PIN)

---

Date Purchased

---

Engine Model

---

Engine (PIN)

---

	<p>This is the safety alert symbol. It is used with and without signal words to alert you to potential personal injury hazards. Obey all safety messages that follow this symbol to avoid possible death or injury.</p>
---	---

### WARNING

Illustrations in this manual may show protective shielding open or removed to better illustrate a particular feature or adjustment.  
Replace all shields before operating the machine.  
Failure to comply could result in death or serious injury.

W0012A

**ATTENTION:** The engine and fuel system on your machine is designed and built to government emission standards. Tampering by dealer, customers, operators, and end users is strictly prohibited by law. Failure to comply

*could result in government fines, rework charges, invalid warranty, legal action, and possible confiscation of the machine until rework to original condition is completed. Engine service and/or repairs must be done by a certified technician only!*

### Improvements

CNH INDUSTRIAL AMERICA LLC is continually striving to improve its products. We reserve the right to make improvements or changes when it becomes practical and possible to do so, without incurring any obligation to make changes or additions to the equipment sold previously.

## Intended use

### INTENDED USE OF YOUR TRACTOR

Your tractor is designed to power and propel itself. The tractor is intended for agricultural use to pull or carry attachments or load and move materials when equipped with a front end loader with a variety of bucket sizes, within some physical limits. The working speed and performance may depend on a number of various parameters, such as weather and terrain conditions. Though the tractor is designed to perform in combination with a variety of equipment in most crops and conditions, there may be a number of combinations of above parameters, for which there is severe degradation of performance of the tractor and/or its mounted or trailed equipment. If you notice degradation of performance, contact your dealer for assistance. He may have useful information for improvements, or a kit may be available to enhance the performance.

- Do not use the tractor for another purpose than intended by the manufacturer and outlined in this manual.
- Do not use the tractor beyond its limits of terrain gradient and stability as outlined further in this manual. Using the tractor beyond these limits may result in roll-over or tip-over. Observe the recommendations in this manual.
- Do not use the tractor on higher speeds than allowed by the load and the environment. A wet surface or other low adherence conditions may increase the braking distance or result in vehicle instability. Always adapt your traveling speed according to the load of the vehicle and the characteristics of the road.
- Do not use the tractor near or on soft verges of canals and brooks or banks and verges that are undermined by rodents. The tractor may sink sideways and roll-over.
- Do not use the tractor on brittle bridge heads and poor bridge floors. These constructions may collapse and cause roll-over of the tractor. Always check out the condition and carrying capacity of bridges and ramps prior to engage.
- Do not use the tractor without wearing the seat restraint system during activities where roll-over or tip-over hazards exist. The ROPS cab or ROPS structure will only be fully effective when the driver remains attached to his seat.
- Do not use equipment mounted on the tractor which is not correctly matching and firmly fixed. Such equipment may increase the risk for roll-over and hit the tractor when coming loose. Ensure that the dimensions of the three-point linkage interface of both the tractor and the equipment are matching according to the categories defined in ISO 730. Ensure that the dimensions and speed of the PTO shaft on the tractors are matching those of the equipment.
- Do not use the tractor in combination with equipment, without having consulted the specific Operators Manual provided with the equipment. The tractor is a universal tool to carry, tow, and drive a variety of equipment. This manual alone cannot provide you with all the information required for the safe operation of the combination.
- Do not use the tractor beyond its limits of dynamic stability. High speed, abrupt maneuvers, and fast and short cornering will increase the risk of roll-over.
- Do not use the tractor for pulling work, in cases where you do not know whether the load will yield, for instance when pulling stumps. The tractor may flip over when the stump is not yielding.
- Be cautious that the center of gravity of the tractor may increase when loads on the front-end loader or the three-point linkage are raised. In these conditions, the tractor may roll-over earlier than expected.
- Do not step down from the tractor without shutting down the PTO, shifting the transmission to park or neutral and applying the park brake, unless continued PTO operation is required for some equipment, such as pumps or wood chippers. The latter equipment may have an emergency stop device on the equipment itself, as human intervention is needed during operation. But other equipment, engaged and driven by the tractor will have no means to stop the power transmission, other than the PTO clutch of the tractor.
- You shall take the necessary precautions to always be aware of the possible presence of bystanders, certainly when maneuvering in confined areas, such as the farm yard and sheds. Keep people away from the tractor during work; ask bystanders to leave the field. There is not only the risk to be overrun by the tractor, but objects ejected by some equipment mounted on the tractor, such as a rotary mower, may cause harm. Stones may be thrown further than the mowed crop. Pay the necessary attention while operating next to public roads or footpaths. Thrown objects can get projected outside the field and hit unprotected people like bikers or pedestrians. Wait to cut the edge of the field till it is clear of bystanders.
- Do not allow riders on the tractor; do not allow people standing on the access way or step to the cab when the tractor is moving. Your view to the left will be obstructed and a rider risks to fall from the tractor during unforeseen or abrupt movements.
- Always stay clear from implements operating area and especially do not stand between tractor and trailed vehicle either three-point linkage when operating lift controls; ensure no bystanders are near these operating areas.
- Certain functions of your tractor, if equipped with a CVT transmission, are controlled by software and some of them are safety related. Do not attempt to modify or download software from spurious sources. Settings and logics may be destroyed and affect seriously the



function of the tractor. This may result in unpredictable and unsafe behavior of the tractor. Only your dealer is entitled to intervene on the software of the tractor. He has the appropriate tools and data sets for it and owns the officially released software versions and updates for your tractor.

- Your tractor may be equipped with a number of sensors to control safety functions. Tripping these sensors will result in a safe operation mode. Do not attempt to bypass any function on the tractor. You will be exposed to serious hazards, and moreover, the behavior of the tractor may become unpredictable.
- A tractor has only one operator station and is a one man operated vehicle. Other people on or around the tractor during normal operation are not allowed.
- The machine is designed and produced exclusively for agricultural use.
- The machine is not designed for light/heavy forestry applications; usage is prohibited for forestry applications.
- All other use will be considered to be contrary to the use specified by CNH INDUSTRIAL AMERICA LLC, who cannot be held liable for damage to property or the machine, or for personal injuries which may result.
- Persons who risk improper use will therefore assume the responsibility for any consequences arising from such use.
- Compliance with the instructions for use, maintenance and repairs described in this manual, are the essential preconditions for the use specified by CNH INDUSTRIAL AMERICA LLC.
- The machine must only be used, serviced, or repaired by personnel trained in the relevant working methods and safety regulations and who have been authorized to work on the machine.
- The user must also observe the rules concerning general safety and accident prevention, including the Highway Code when driving on public highways.
- Any arbitrary modifications made to this machine will release CNH INDUSTRIAL AMERICA LLC from any liability resulting from damage or injury.
- CNH AMERICA LLC and all its distribution organizations, inclusive of, but not restricted to, national, regional, or local distributors, cannot be held liable for damage resulting from the malfunction of parts and/or components not approved by CNH INDUSTRIAL AMERICA LLC.
- Under no circumstances will a guarantee be issued for products made or sold by CNH INDUSTRIAL AMERICA LLC that are damaged as a result of the malfunction of parts and/or components not approved by CNH INDUSTRIAL AMERICA LLC.
- The use of biodiesel blends meeting Specification Standards ASTM 6751 or EN14214 are approved for your engine up to B5 (5% blend ratio). It is highly recommended to use biodiesel fuel from accredited suppliers to maintain quality and consistency of the fuel.

## Electro-Magnetic Compatibility (EMC)

Interference may arise as a result of add-on equipment that may not necessarily meet the required standards. As such interference can result in serious malfunction of the unit and/or create unsafe situations, you must observe the following:

- The maximum power of emission equipment (radio, telephones, etc.) must not exceed the limits imposed by the national authorities of the country where you use the machine
- The electro-magnetic field generated by the add-on system should not exceed **24 V/m** at any time and at any location in the proximity of electronic components
- The add-on equipment must not interfere with the functioning of the on board electronics

Failure to comply with these rules will render the NEW HOLLAND warranty null and void.

## Product Identification Number (PIN)

A PRODUCT IDENTIFICATION PLATE (PIN) is located on the left-hand side of the front frame.

This plate contains tractor, engine and transmission identification numbers.

Record these numbers on **1-1**

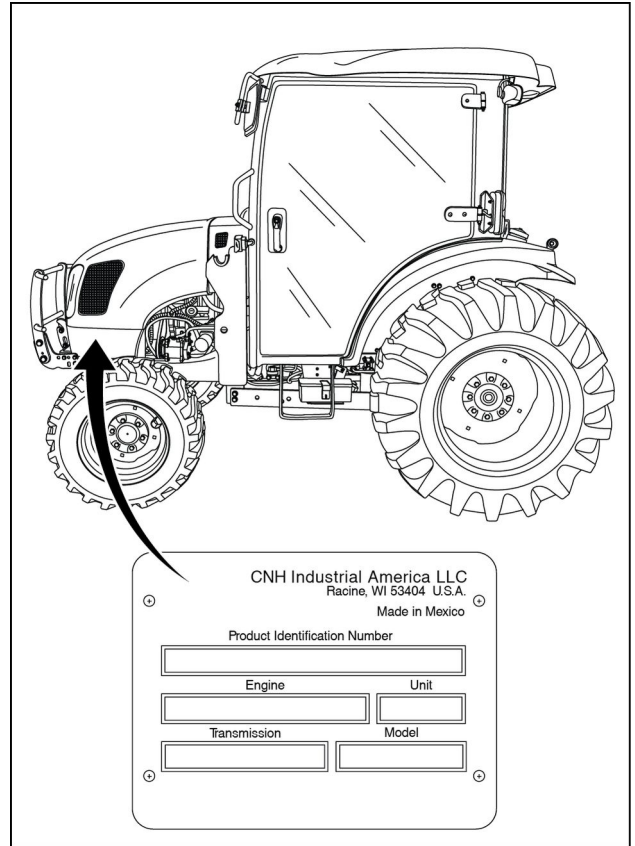

NHIL14CT00685BA 1

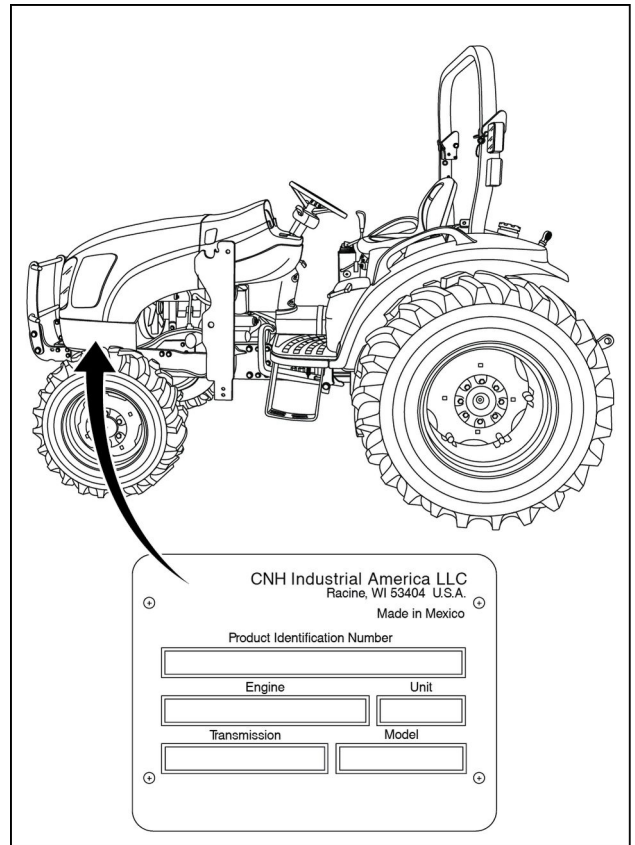

NHIL14CT00686BA 2

1 - GENERAL INFORMATION

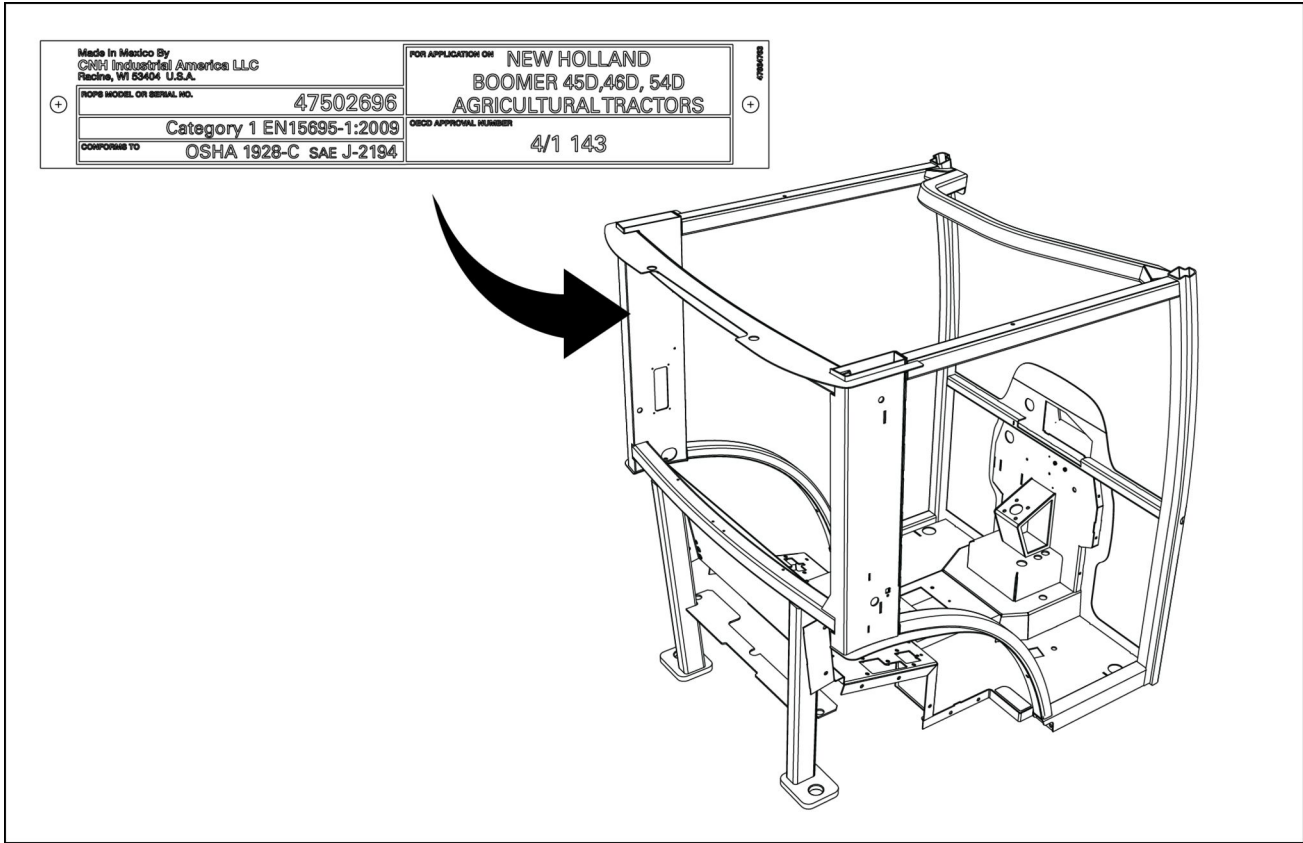

NHIL15CT00167FA 3

A CAB IDENTIFICATION PLATE is located inside on the left rear pillar of the cab. The identification numbers on these plates are important in the event your tractor should require future service. For you convenience, have your dealer record these numbers in the appropriate spaces below.

Cab Identification # \_\_\_\_\_

CNH America LLC is continually striving to improve its products. We reserve the right to change prices, specifications, or equipment at any time without notice.

All data given in this book is subject to production variations. Dimensions and weights are approximate only, and the illustrations do not necessarily depict tractors in standard condition. For exact information about any particular tractor, please consult your NEW HOLLAND dealer.

## **Operator's manual storage on the machine**

Recommend storage area for operator's manual

- A. Cab tractor -Inside cab
- B. ROPS tractor - Inside tool box

## Machine orientation

### Cab models

**NOTE:** On this equipment, left-hand and right-hand are determined by standing behind the unit, looking in the direction of travel.

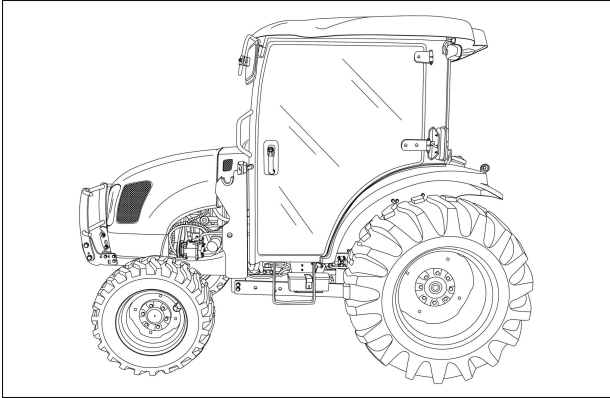

NHIL14CT00655FA 1

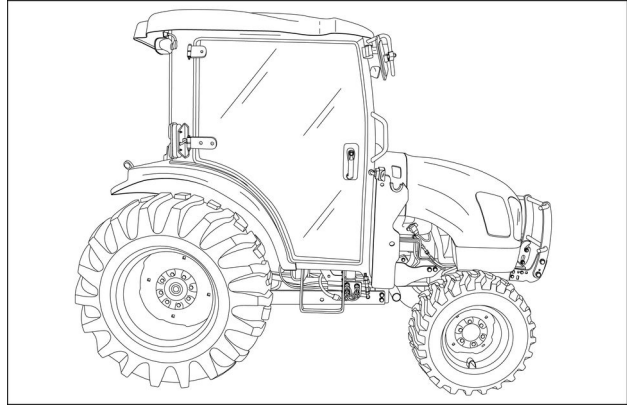

NHIL14CT00657FA 2

### Left-hand view

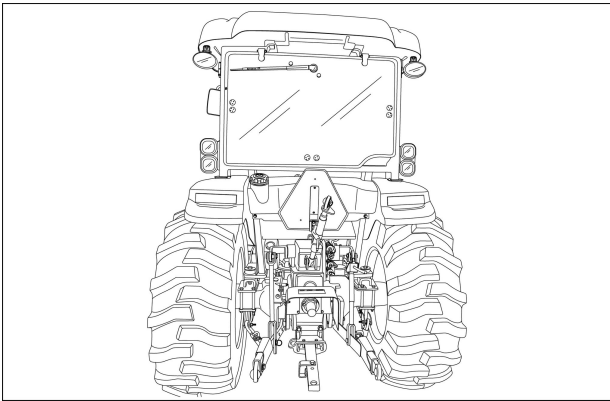

NHIL14CT00656FA 3

### Right-hand view

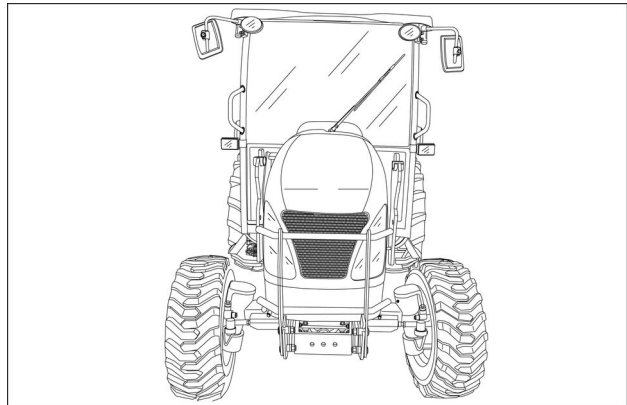

NHIL14CT00658FA 4

### Rear view

### Front view

## ROPS models

**NOTE:** On this equipment, left-hand and right-hand are determined by standing behind the unit, looking in the direction of travel.

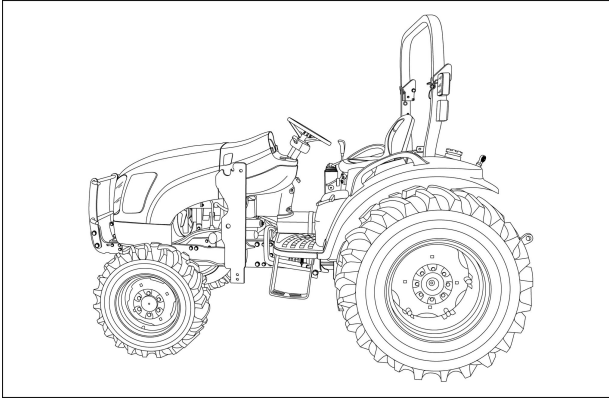

NHIL14CT00653FA 5

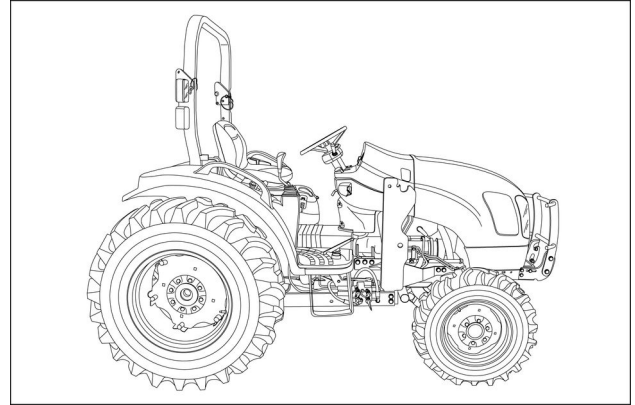

NHIL14CT00651FA 6

## Left-hand view

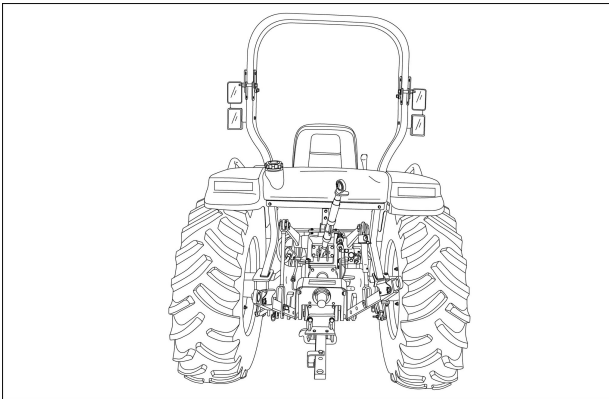

NHIL15CT00165FA 7

## Right-hand view

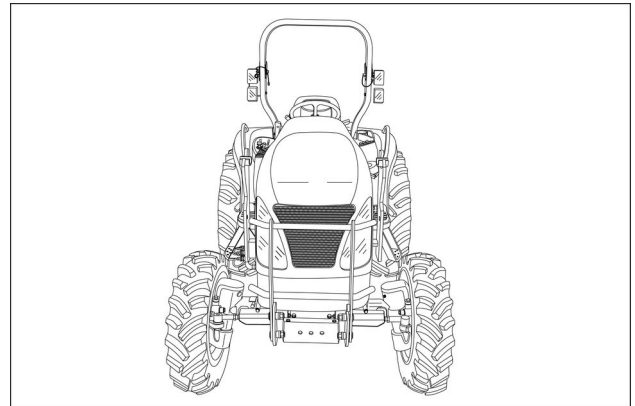

NHIL14CT00652FA 8

## Rear view

## Front view

Thank you so much for reading.  
Please click the “Buy Now!”  
button below to download the  
complete manual.



After you pay.

You can download the most  
perfect and complete manual in  
the world immediately.

Our support email:

[ebooklibonline@outlook.com](mailto:ebooklibonline@outlook.com)