

ORIGINAL INSTRUCTIONS - in conformity with EU Regulation 2014/11322, Annexe XXII

OPERATOR'S MANUAL

T4.90 FB

T4.100 FB

T4.110 FB

Tractor

Part number 51427774

1st edition English
January 2018



SUMMARY

Chapter No.	Description
1	GENERAL INFORMATION
2	GENERAL SAFETY RULES
3	TECHNICAL CHARACTERISTICS
4	CONTROLS AND INSTRUMENTS
5	OPERATING INSTRUCTIONS
6	SERVICE PROCEDURES
7	TROUBLESHOOTING

I : General information

Index

1.1 Introduction	1-2
1.2 Note for owner	1-3
1.3 Correct and incorrect use of tractor	1-5
1.3.1 Intended use	1-5
1.3.2 Improper and incorrect use	1-7
1.3.3 Electromagnetic compatibility (EMC)	1-7
1.4 General information and required training	1-8
1.4.1 Using the manual	1-8
1.4.2 Unified indicator symbols	1-9
1.4.3 Units of measurement used in this manual	1-11
1.4.4 Terms used to denote direction	1-11
1.4.5 Tractor delivery procedure.....	1-12
1.4.6 Responsibilities of the owner of the tractor	1-12
1.4.7 Responsibilities of operators.....	1-13
1.4.8 Warranty	1-13
1.5 Identification plates	1-14
1.5.1 Location of machine identification data	1-14
1.5.2 Engine information	1-14
1.5.3 Chassis.....	1-15
1.5.4 Tractor identification plate.....	1-16
1.5.5 Label with type of protective structure	1-17
1.6 Cab category	1-18

I.1 Introduction

Keep this "Use and maintenance manual" with care and remember to refer to it regularly.

Due to the considerable diversity possible in operating conditions, the documentation produced by the manufacturer cannot take every possible variable into account regarding the performance and operation of the vehicles it manufactures. It therefore cannot be held responsible for loss or damage deriving from the content of these publications or due to any errors or omissions. If the vehicle is to be used in particularly heavy-duty and unusual conditions (e.g. in deep water or very muddy soil), we recommend contacting your dealer beforehand for specific instructions to prevent voiding the warranty.

The manufacturer of the tractor cannot be held liable for any damage or injury caused by improper use of the vehicle, the risks of which are solely the user's responsibility.

Compliance with and strict observance of the conditions of use, servicing and repair specified by the manufacturer are also an essential part of intended use.

To use, service and repair this tractor, you must be fully aware of all of its specific characteristics and be informed about the relative safety standards and regulations (accident prevention).

We recommend contacting an official dealer for any queries concerning servicing or settings.

All rights reserved. This manual may not be reproduced or copied, in whole or in part, without the prior written permission of the manufacturer.

Note that all brands other than brands owned by the CNH Industrial Italia S.p.A., subsidiaries of the group, licensee companies and companies controlled by the group, and relative to third party products and/or services cited in this document, are the sole property of the respective trademark owners.

1.2 Note for owner

This manual contains the information necessary to ensure that the machine is serviced correctly. This machine is inherently reliable. However, the performance and durability of the machine depend on proper maintenance and correct operation. This manual must be read by all persons operating the machine and must be kept close at hand at all times.

Upon delivery of the new machine, the dealer will provide the owner with general instructions for operation. Our service personnel will be happy to answer any queries regarding the operation of the machine.

The dealer has a comprehensive range of genuine spare parts. These spare parts are manufactured and inspected with care to ensure the necessary superior quality and reliability. When ordering spare parts, provide the dealer with the product identification number and the model code. Copy these numbers into the relative spaces below as soon as you take delivery of the new product. See the section "General information" in this manual for the location of the product identification number and the model code.

Contact an authorised dealer for information on and ordering any additional equipment available. Use the identification information of your vehicle, copied manually onto this page from the identification plates.

 Note
Using only original spare parts will protect the tractor and keep it in good working order. Using non-original spare parts or installing spare parts incorrectly will void the warranty.

COPY THE FOLLOWING DETAILS IN THE SPACE BELOW

Model:	
Tractor identification number:	
Engine identification number:	
Date of purchase:	
Name of authorised dealer:	
Telephone number of authorised dealer:	

A number of safety warning decals are applied to the machine, which may or may not also include a caution message, to warn the user of potential hazards which could lead to personal injury. Observe all safety messages to prevent the risk of injury or death

The machine has been designed and constructed in compliance with the quality standards required by current safety legislation. In spite of this, the risk of accidents can never be eliminated completely. This is why it is imperative to follow the basic safety rules and precautions given. To prevent the risk of injury when repairing the machine, before you start work, read this manual thoroughly and, in particular, the instructions concerning safety, operation and maintenance.

Only use this machine for the tasks and applications indicated in this manual. In the case of tasks requiring the machine to be used together with special implements, contact your dealer to be certain that the modifications necessary are compatible with the technical specifications of the machine itself and conformant with applicable safety regulations.

Modifications made to the machine without the approval of the manufacturer may render the machine no longer conformant with safety requirements.

The instruction manual must always be kept on board the machine. Make sure that the manual is complete and in good condition. Contact your dealer to request additional copies of the manual or versions in languages other than the language of the country of use.

The manufacturer is dedicated to continuously improving its products. The manufacturer therefore reserves the right to implement improvements or modifications as it deems necessary, without extending these modifications or improvements to any machine sold beforehand

The machine must be inspected periodically at intervals determined by the usage of the machine itself. Contact an authorised dealer for more information.

 **Warning**

The contents of this manual are based on the information available at the time of writing. Settings, procedures, part numbers, software and other elements may be subject to change, with possible ramifications for the maintenance procedures for the machine. Before operating the machine for the first time, contact your dealer to make sure that you have the latest and most complete version of the manual. All the contents of this manual may be subject to modification to reflect changes in production.

 **Attention**

The injection system and the engine installed on this machine are conformant with governmental emissions standards. Any tampering with the machine is strictly prohibited by law. Non observance of this directive may:

- render you liable to fines;
- render you liable for repair costs;
- void the warranty;
- render you liable to legal action and lead to the vehicle being confiscated until it is restored to its original state.

 **Attention**

Maintenance and/or repair work on the engine must only be performed by specialised technicians!

I.3 Correct and incorrect use of tractor

I.3.1 Intended use

 **Note**

The machine has been designed and constructed in conformity with EU directives for the prevention of risks to health and safety. This manual must be read in full in order to minimise risks and avoid exposing the operator and other persons to risk or danger. The operator must understand and comply with all the instructions and warnings indicated on decals, plates and labels applied to the machine. Contact your dealer for any queries on this matter.

 **Note**

The tractor is approved for use on public road provided that it is registered correctly and carries a legal license plate.

To operate this tractor in accordance with its intended use, it is necessary to follow the instructions in this manual, along with the routine maintenance and repair rules stipulated by the manufacturer.

The persons who use, maintain and repair the tractor must have a good knowledge of the tractor and the associated risks, and must be suitably trained and informed with regards the correct way to drive the tractor, the contents of this manual and the rules stipulated by the manufacturer.

The persons who use, maintain and repair the tractor must always comply with the rules regarding workplace health and safety, occupational health and road traffic legislation in order to avoid accidents that could cause personal injury or death.

Any usage not complying with the conditions stated above will be deemed improper and incorrect use and will automatically relieve the manufacturer of any responsibility in the event of an accident. In this situation, the user will be entirely responsible and liable.

All persons using the machine must be in possession of locally valid authorisation to drive the vehicle or observe applicable local regulations.

Read and observe the following instructions with particular care:

- Only use the machine for the usage intended by the manufacturer and indicated in this manual.
- Use the tractor safely.
- Connect implements correctly. Using non-approved or incorrectly installed implements and accessories may result in overturning caused when the implement or accessory detaches from the tractor.
- Ensure that the three point linkage meets the requirements of ISO 730 standards.
- Check that the speed and dimensions of the power take off on the tractor are correct for the connected implement.
- Read the specific instruction manual provided with the implement thoroughly before operating an implement connected to the tractor. The tractor is a tool that may be used in a variety of different configurations. It would not be possible to provide comprehensive safety information in this manual encompassing ever possible configuration of the machine.
- Before using the tractor for towing or stump-pulling, check carefully that the draft force setting is correct. When using the machine for pulling stumps in particular, the machine may overturn if the stump fails to yield from the soil.
- When lifting weights with a front loader or with the rear three point linkage, the centre of gravity of the tractor may raise. In these conditions, the risk of sudden overturning is increased.
- Only leave the driver seat and alight from the tractor after doing the following:
 - Set the gear lever to neutral.
 - Engage the parking brake and, if applicable, the park lock.
 - Disengage the PTO (unless the specific implement connected requires the PTO to remain running).
 - Lower any implements connected to the machine to the ground.
- Especially when in restricted spaces, make sure that there are no persons in the vicinity of the machine when manoeuvring.
- Inform all persons in the vicinity that they must leave and keep out of the work area before starting work. When working, there is a risk of being hit by objects expelled by the implement connected to the tractor (rotary mowers, rotary harrows etc.).
- Take particular care when working near roads or pathways. Objects may be projected out of the work area and hit passers-by. Stop and wait for the area to clear before continuing work.
- Nobody other than the operator is allowed on the tractor. Do not allow other persons to climb onto the cab access ladder while the tractor is moving. In addition to limiting the driver's field of view, there is also a risk of the person carried falling off the tractor.
- Keep at a safe distance from the work area of implements. Keep out of the space between the machine and the implement or towed vehicle when using the external lift controls. Ensure that there are no unauthorised persons in the work area.
- The tractor is equipped with software which controls a number of its safety functions. Never tamper with these functions for any reason or load software onto the system that is not certified by the constructor. Non certified software may compromise the functions of the tractor. Non certified software may cause abnormal tractor behaviour, reducing both performance and safety. Any procedure concerning the software must only be performed by your dealer.
- Certain safety functions are controlled by sensors. These sensors must be in proper working order for the safety functions to be effective.
- The tractor is equipped with a single driver seat only and is therefore only intended to be operated by one user at a time.

1.3.2 Improper and incorrect use

Any use other than those specifically intended by the constructor is deemed improper and incorrect. The constructor cannot be held liable in the event of any accident caused by improper use. The user is responsible for all risks deriving from improper use.

The following is a list of examples of improper usage of this tractor which will put the life of the operator at risk.

- Allowing the tractor to be operated by persons who have not received adequate training.
- Using the tractor in terrain conditions and spaces not classifiable as agricultural working areas or maintenance areas
- Carrying persons on the tractor without a passenger seat. Transporting persons not seated correctly in the passenger seat (on tractors equipped with a passenger seat). Carrying a passenger while driving in the field, even if seated in the passenger seat.
- Using the tractor for competitions or sports events.
- Using the vehicle to herd animals.
- Starting and operating the tractor from outside the cab.
- Exceeding the maximum permissible load.
- Non-observance of the warnings given on the tractor and in this manual.
- Performing repairs and maintenance on the tractor while it is running and/or moving.
- Performing maintenance, cleaning and adjustment without observing the safety rules given in this manual.
- Modifying the tractor without obtaining prior authorisation from the dealer or constructor.
- Connecting implements/equipment to the tractor that are incompatible with each other and/or with the tractor, or connecting unauthorised implements/equipment to the tractor.
- Using non-original spare parts.

1.3.3 Electromagnetic compatibility (EMC)

This machine is conformant with EU regulations concerning electromagnetic radiation. However, interference may be caused by the use of auxiliary equipment. This may occur if the auxiliary equipment used does not comply with the standards defined by the aforementioned regulations.

This interference may cause severe malfunctions and compromise the safety of the machine.

Follow the instructions given below to avoid problems caused by interference:

- check that all third party equipment installed on the machine bears the CE mark;
- the maximum power of transmitting devices must not exceed the limits set by law in the country of use of the machine;
- the electromagnetic field generated by auxiliary equipment must never exceed 24 V/m in any position near electronic components.

Non observance of these rules will render the manufacturer's warranty of the machine null and void.

I.4 General information and required training

I.4.1 Using the manual

This manual contains comprehensive information relative to servicing and using the machine and the describes the procedures necessary to keep the machine in good working order.

Some of the procedures described may only be performed by the specialised personnel of the dealer as they may require special tools and equipment not included with the machine itself.

All persons using this tractor must read this manual thoroughly to allow them to:

- identify all hazards associated with using the tractor;
- identify the components of the tractor and understand their functions, and identify all controls and instruments correctly in order to operate the tractor safely;
- be aware of the correct regular maintenance intervals and procedures to ensure that the machine is used safely and correctly;
- quickly identify and localise any faults and take the correct action necessary in an emergency.

The manual must always be kept in the specific document holder on board the tractor for the entire lifespan of the tractor itself.























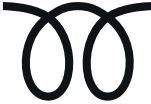

 Note
--

If the tractor changes hands, the manual must always be passed on to the new owner. If the tractor is handed over to the new owner without the operator manual, this may put the new owner at risk as they will have no way of knowing the safety rules for usage and the functions and features of the tractor itself.

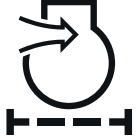
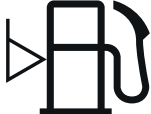

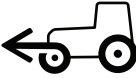

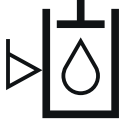







The following documents are provided together with the user manual:

- Warranty certificate: containing the details of the dealer and customer and spaces for service stamps.
- Warranty conditions: describing in detail all the components covered by the warranty, all components and faults not covered by the warranty and the conditions which will render the warranty null and void.

I.4.2 Unified indicator symbols

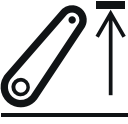
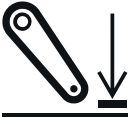
Symbol	Description	Symbol	Description	Symbol	Description
	Fault indicator		Horn		Alarm indicator
	High beam headlights indicator		Dipped headlights indicator		Work light indicator
	Rotating beacon indicator		Sidelights indicator		Read the instruction manual
	Turn signal indicator		Battery state of charge indicator		Rear screen washer/wiper indicator
	Windscreen wiper indicator		Windscreen wiper/washer indicator		Engine oil pressure indicator
	Engine water temperature indicator		Engine speed indicator		Engine preheat indicator
	Engine fault indicator		Engine air filter clogged indicator		Fuel level indicator
	Fuel system fault indicator		Four wheel drive indicator		Differential lock indicator
F	Forward drive selected indicator	N	Neutral indicator	R	Reverse drive selected indicator
	Hydraulic fluid level indicator		Brake warning indicator		Parking brake indicator

I - GENERAL INFORMATION

	Transmission oil pressure indicator		Service indicator; see the technical manual		Rear PTO indicator
	Front PTO indicator	750	Rear PTO 750 rpm mode indicator	540	Rear PTO 540 rpm mode indicator
	Fluid level indicator		Braking system, first trailer or first auxiliary circuit		Braking system, second trailer or second auxiliary circuit
	Lift down indicator		Upper lift limit reached indicator		Lower lift limit reached indicator
	Hydraulic oil filter indicator		Pressure indicator		Diesel particulate filter sensor (emissions control system)

I.4.3 Units of measurement used in this manual

The units of measurement used in this manual are listed as follows:

Symbol	Description
°C	Degrees centigrade
A	Amperes
cm	Centimetres
cm ³	Cubic centimetres
dB(A)	Decibels
g	Grammes
rpm	rpm
h	Hour
kg	Kilogrammes
km/h	Kilometres per hour
kW	Kilowatts
l	Litres
m	Metres
m ³	Cubic metres
min	Minutes
mm	Millimetres
N	Newtons
Nm	Newton metres
Pa	Pascals
s	Seconds
V	Volts
W	Watts

I.4.4 Terms used to denote direction

The following terms are used in this manual to denote directions and parts of the tractor as viewed from the driver seat:

- 1 - Front
- 2- Right
- 3 - Rear
- 4- Left

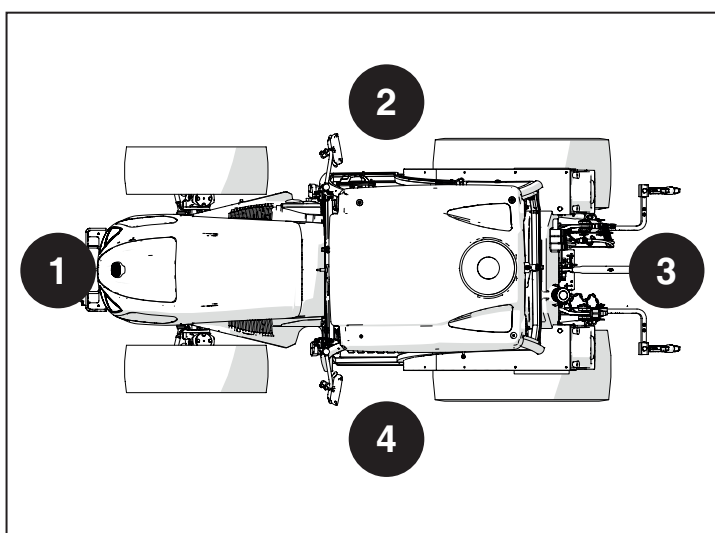

Fig. I.1

Thank you so much for reading.
Please click the “Buy Now!”
button below to download the
complete manual.



After you pay.

You can download the most
perfect and complete manual in
the world immediately.

Our support email:

ebooklibonline@outlook.com